

S/M No. : FR540NT010

Service Manual

Refrigerator

Model:FR-540N

DAEWOO



DAEWOO ELECTRONICS CO., LTD.

1. SPECIFICATION

MODEL NAME		FR-540N	
Refrigerant	R12	200g	
	R134a	170g	
Cooling System		Fan Cooling Convection	
Refrigeration System		Air Forced Convection	
Defrost System		Fin Evaporator Forced	
Defrost Operation		Automatic Start & Stop	
Cold Control		Adjustable Button	
Capacity	Freezer	119 ℓ	
	Refrigerator	315 ℓ	
	Total	434 ℓ	
External Dimension	Height	1768mm	
	Width	770mm	
	Depth	700mm	
Net Weight		89Kg	

2. EXTERNAL VIEW

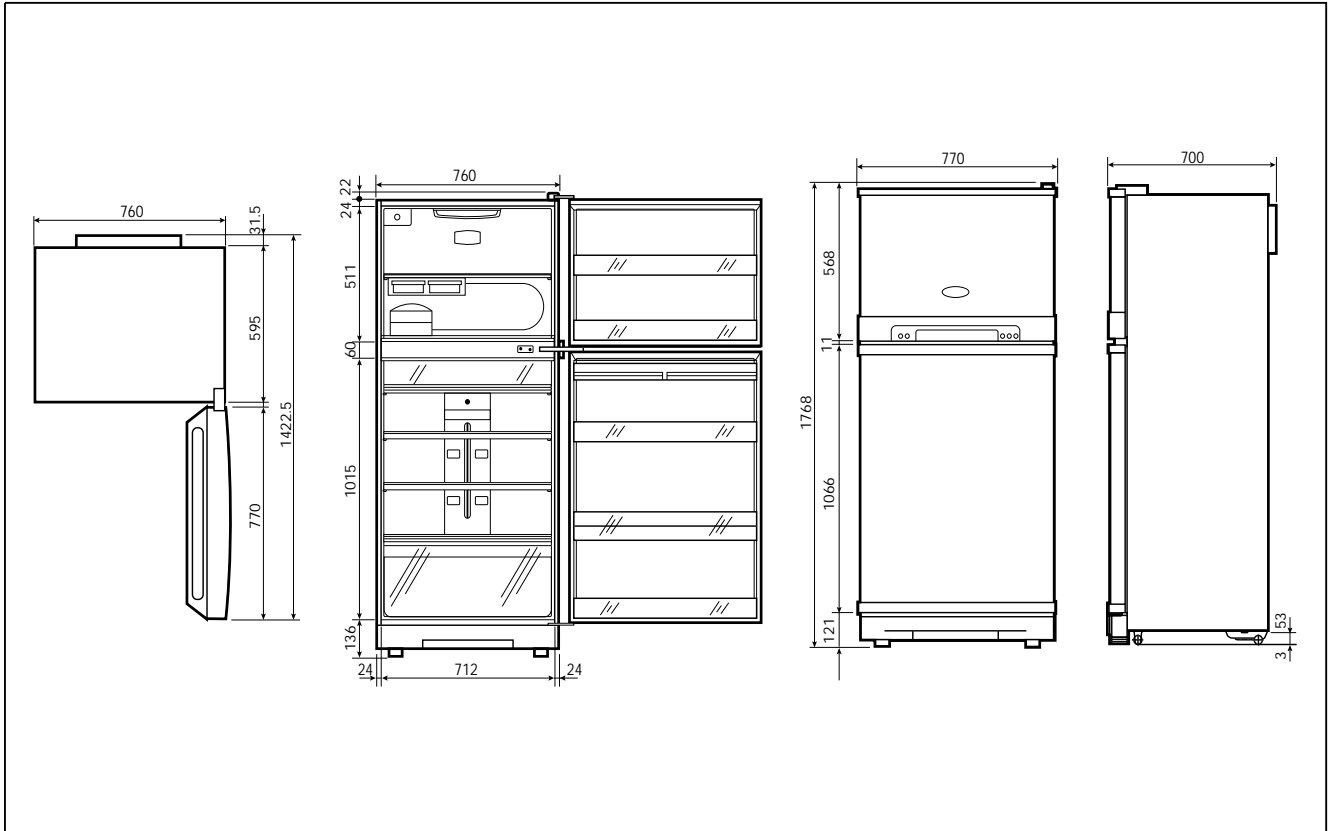

3. WIRE DIAGRAM

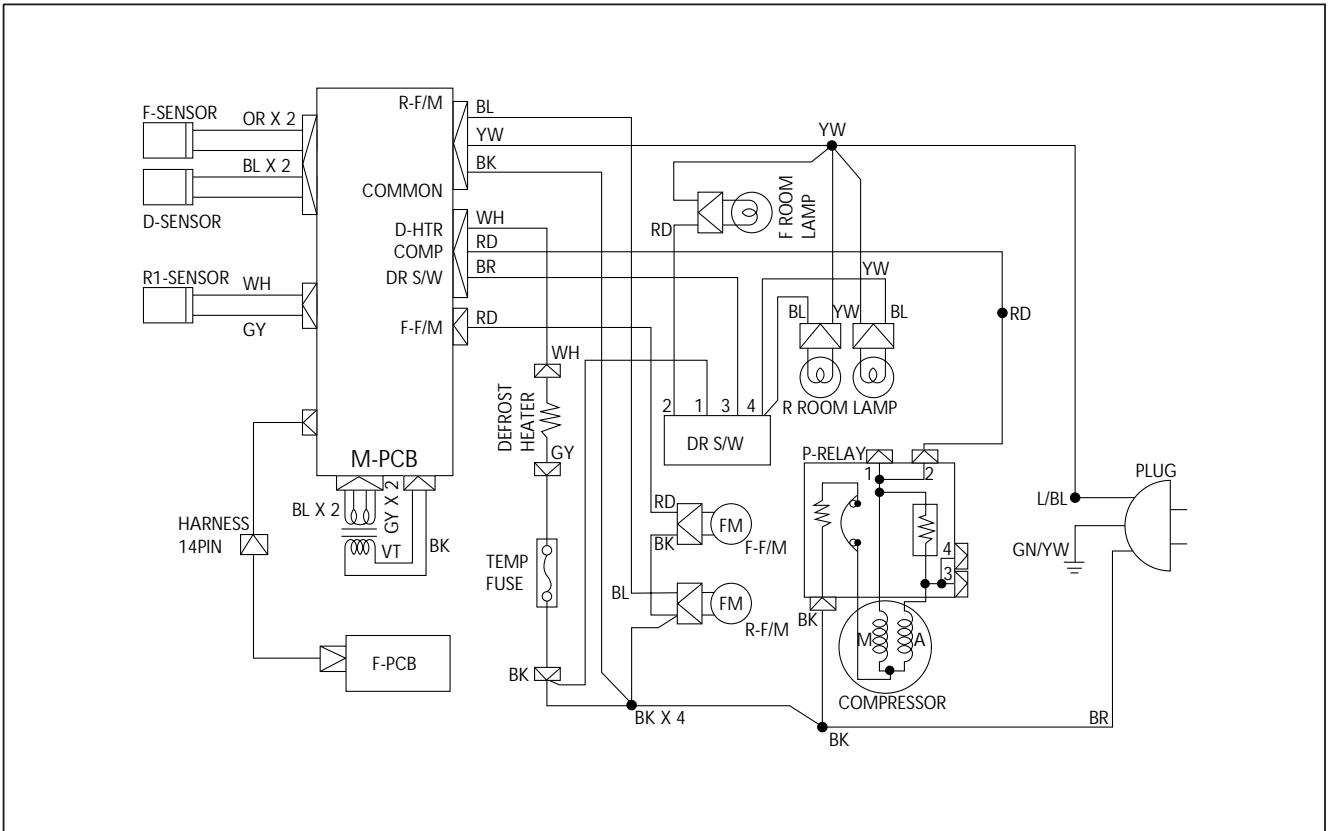

4. NAME OF PARTS

1. FR-540N

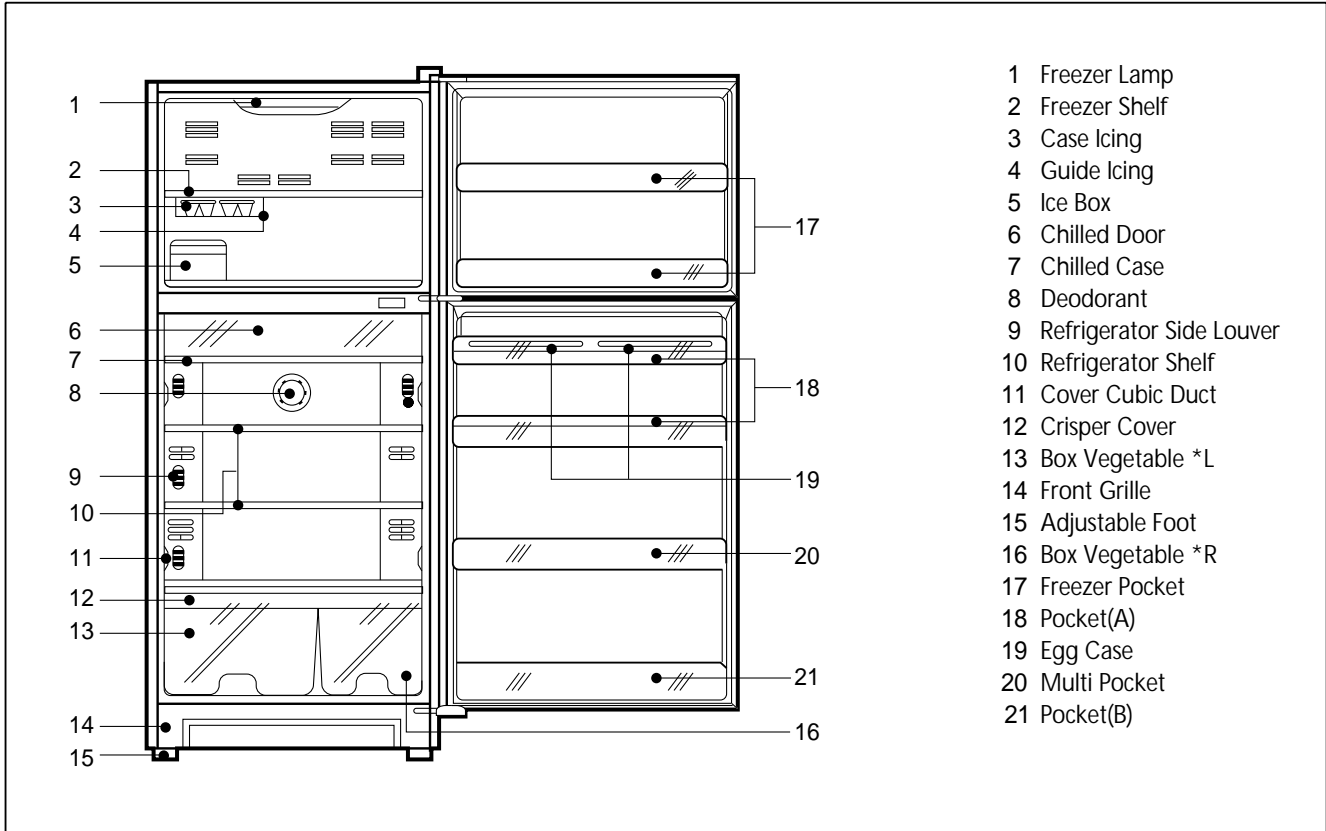

- 1 Freezer Lamp
- 2 Freezer Shelf
- 3 Case Icing
- 4 Guide Icing
- 5 Ice Box
- 6 Chilled Door
- 7 Chilled Case
- 8 Deodorant
- 9 Refrigerator Side Louver
- 10 Refrigerator Shelf
- 11 Cover Cubic Duct
- 12 Crisper Cover
- 13 Box Vegetable *L
- 14 Front Grille
- 15 Adjustable Foot
- 16 Box Vegetable *R
- 17 Freezer Pocket
- 18 Pocket(A)
- 19 Egg Case
- 20 Multi Pocket
- 21 Pocket(B)

5. AIR FLOW DIAGRAM

1. FR-540N

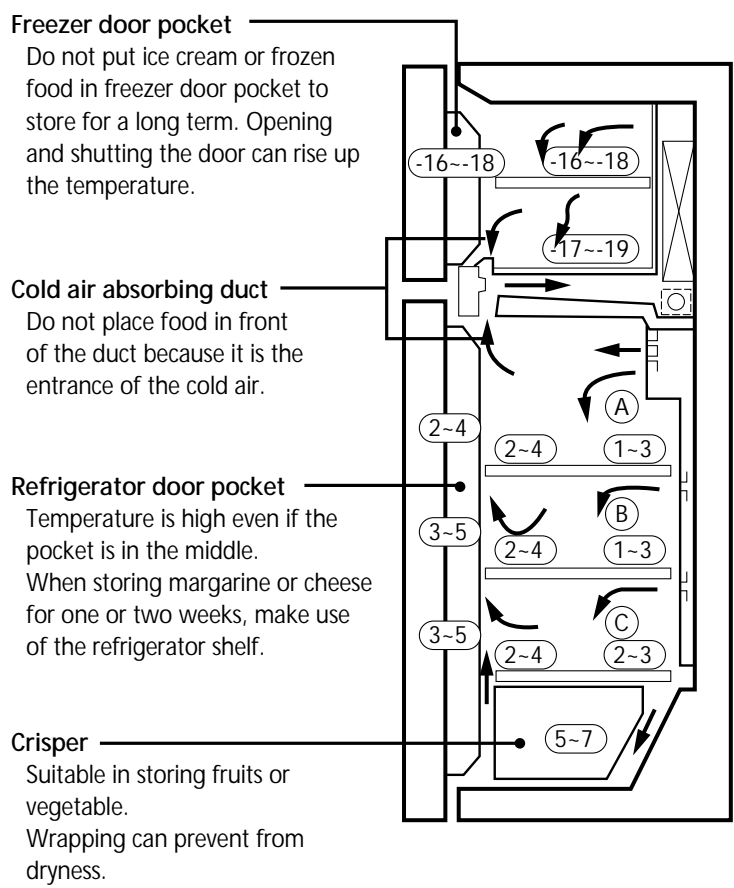

Freezer door pocket
Do not put ice cream or frozen food in freezer door pocket to store for a long term. Opening and shutting the door can rise up the temperature.

Cold air absorbing duct
Do not place food in front of the duct because it is the entrance of the cold air.

Refrigerator door pocket
Temperature is high even if the pocket is in the middle. When storing margarine or cheese for one or two weeks, make use of the refrigerator shelf.

Crisper
Suitable in storing fruits or vegetable. Wrapping can prevent from dryness.

Freezer room
Do not put any bottle such as beer or beverage because it can be frozen and broken.

Refrigerating room
This model is multi-flow type which flows out cold air from each shelf space. The hot air after making the refrigerator cold, flows into cooling system through the front upper part.

Do not put food having much moisture at the middle part of each shelf space ("A", "B" and "C" part). It can be frozen owing to the low temperature.

6. REFRIGERANT CYCLE DIAGRAM

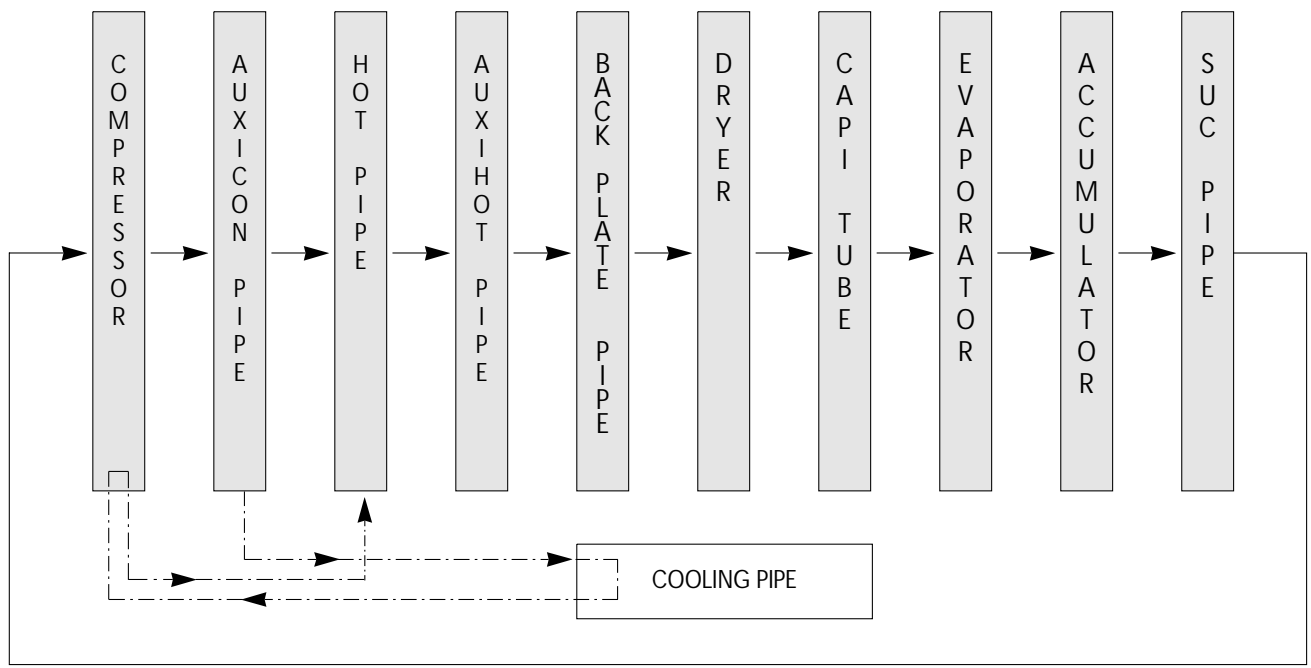
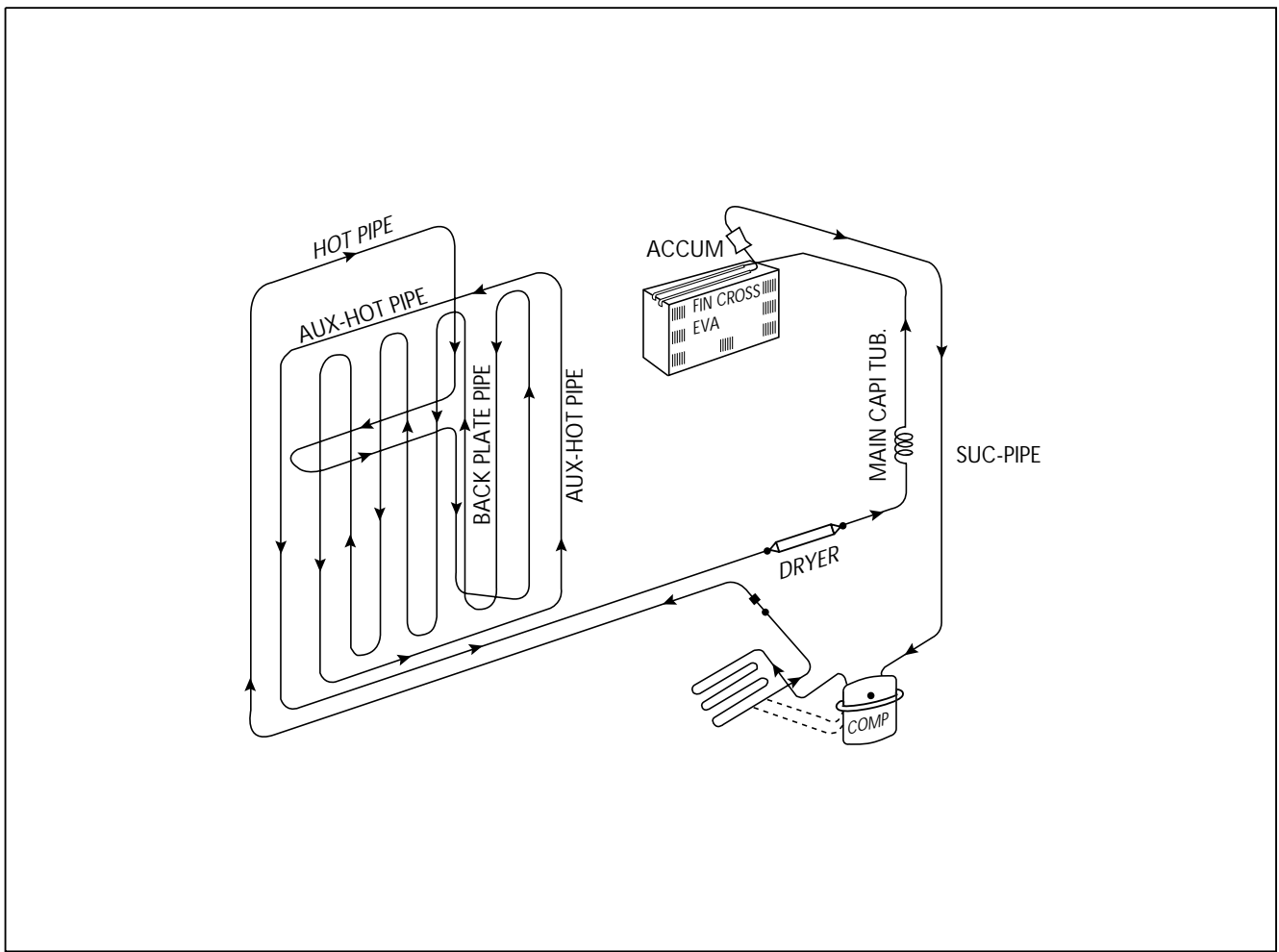

7. MACHINE ROOM VIEW AND PART LIST

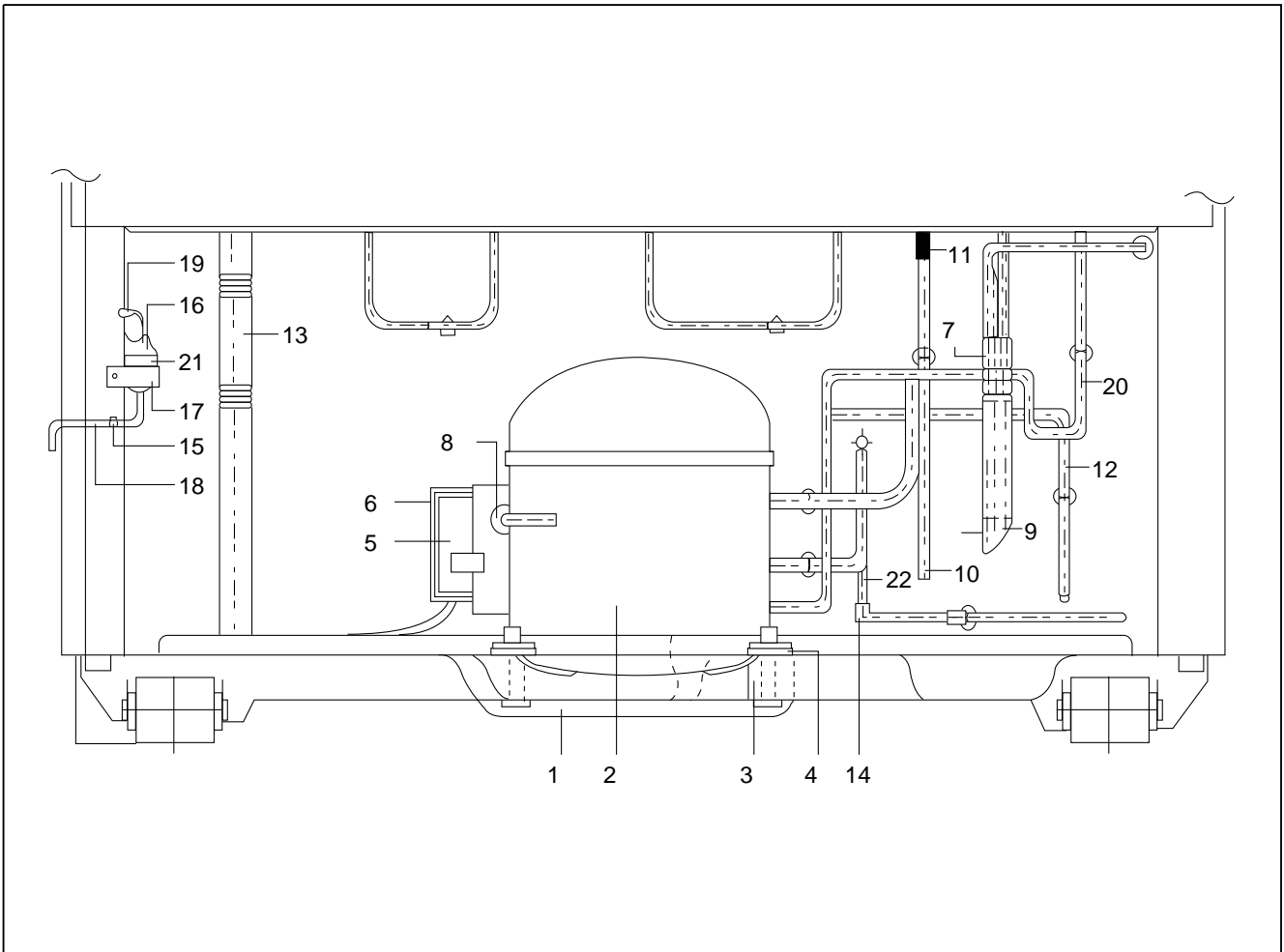

NO	PART NAME	NO	PART NAME	NO	PART NAME
1	BASE COMPRESSOR	9	DRYER	17	BIND WIRE
2	COMPRESSOR	10	PIPE CON (SUC)	18	PLUG POWER AS
3	ABSORBER COMPRESSOR	11	VIBRATIONPROOF GUM	19	SCREW MACHINE
4	WASHER COMP. *T	12	PIPE CON (AUX)	20	PIPE CON (HOT)
5	SWITCH P-RELAY AS	13	HOSE DRAIN (B)	21	TAPE OPP
6	BAND RELAY	14	VIBRATIONPROOF MASS	22	PIPE CON (P.A)
7	TAPE COTTON	15	SCREW TAPPING		
8	PIPE SERVICE	16	COVER CONNECTOR		

8. MAIN COMPONENTS

1. COMPRESSOR

Refrigerant	R12							
Voltage	100V/50,60Hz	110V/60Hz	115, 120V/60Hz	127V/60Hz	220V/50Hz	220V/60Hz	230V/50Hz	240V/50Hz
Comp. model	X	BL25YE-3	BL25YE-1	X	PL28YE-6	PL25YE-4	PL28YE-6	←
Part code	X	3952125C30	3952125C10	X	3956128C60	3956128C40	3956128C60	←
Strating type	X	CSR	CSR	X	RSCR	RSCR	RSCR	←

Refrigerant	R134a							
Voltage	100V/50,60Hz	110V/60Hz	115, 120V/60Hz	127V/60Hz	220V/50Hz	220V/60Hz	230V/50Hz	240V/50Hz
Comp. model	X	HBL25YG-3	HBL25YE-1	X	HSL27YE-5	X	HSL27YE-5	←
Part code	X	3952125L3A		X	3954127L50	X		←
Strating type	X	CSR	CSR	X	RSIR	X	RSIR	←

2. RELAY ASSEMBLY

Refrigerant	R12							
Voltage	100V/50,60Hz	110V/60Hz	115, 120V/60Hz	127V/60Hz	220V/50Hz	220V/60Hz	230V/50Hz	240V/50Hz
Relay model	X	419RHBYY-52	427THBYY-52	X	213THBYY-52	197SHBYY-52	X	213THBYY-52
Part code	X	3018105673	3018105690	X	3018105651	3018104102	X	3018105651

Refrigerant	R134a							
Voltage	100V/50,60Hz	110V/60Hz	115, 120V/60Hz	127V/60Hz	220V/50Hz	220V/60Hz	230V/50Hz	240V/50Hz
Relay model	X	445RHBZZ-52	445RHBZZ-52	X	276THBYY-52	X	276THBYY-52	←
Part code	X	3018101601	3018101600	X	3018105031	X	3018109901	3018105031

3. RUNNING CAPACITOR

Refrigerant	R12							
Voltage	100V/50,60Hz	110V/60Hz	115, 120V/60Hz	127V/60Hz	220V/50Hz	220V/60Hz	230V/50Hz	240V/50Hz
Spec.	X	300V/7μF	←	X	350V/5μF	←	X	350V/5μF
Part code	X	3816800400	←	X	400EL15110	←	X	400EL15110

Refrigerant	R134a							
Voltage	100V/50,60Hz	110V/60Hz	115, 120V/60Hz	127V/60Hz	220V/50Hz	220V/60Hz	230V/50Hz	240V/50Hz
Spec.	X	300V/7μF	←	X	X	X	X	X
Part code	X	3816800400	←	X	X	X	X	X

4. STARTING CAPACITOR

Refrigerant	R12							
Voltage	100V/50,60Hz	110V/60Hz	115, 120V/60Hz	127V/60Hz	220V/50Hz	220V/60Hz	230V/50Hz	240V/50Hz
Spec.	X	200V/100 μ F	←	X	X	X	X	X
Part code	X	401RD35050	←	X	X	X	X	X

Refrigerant	R134a							
Voltage	100V/50,60Hz	110V/60Hz	115, 120V/60Hz	127V/60Hz	220V/50Hz	220V/60Hz	230V/50Hz	240V/50Hz
Spec.	X	200V/100 μ F	←	X	X	X	290V/50 μ F	X
Part code	X	401RD35050	←	X	X	X	4124G62052	X

5. F-FAN MOTOR

Refrigerant	R12, R134a							
Voltage	100V/50,60Hz	110V/60Hz	115, 120V/60Hz	127V/60Hz	220V/50Hz	220V/60Hz	230V/50Hz	240V/50Hz
Spec.	X	3211DWBFN	3211DWBFN	X	3211DWBFR	3211DWBFI	3211DWBFT	←
Part code	X	3011800840	3010027140	X	3011800930	3015902500	3011801020	←

6. R-FAN MOTOR

Refrigerant	R12, R134a							
Voltage	100V/50,60Hz	110V/60Hz	115, 120V/60Hz	127V/60Hz	220V/50Hz	220V/60Hz	230V/50Hz	240V/50Hz
Spec.	X	3211DWBFM	3211DWBFU	X	3211DWBFO	3211DWBFE	3211DWBFS	←
Part code	X	3011800850	3011801000	X	3010027220	3015902600	3011801030	←

7. DEFROST HEATER

1) FR-540N

Refrigerant	R12, R134a							
Voltage	100V/50,60Hz	110V/60Hz	115, 120V/60Hz	127V/60Hz	220V/50Hz	220V/60Hz	230V/50Hz	240V/50Hz
Spec.	X	148W	←	X	148W	←	←	←
Part code	X	3012801300	←	X	3012801000	←	←	←

8. LAMP ASSEMBLY

Refrigerant	R12, R134a							
Voltage	100V/50,60Hz	110V/60Hz	115, 120V/60Hz	127V/60Hz	220V/50Hz	220V/60Hz	230V/50Hz	240V/50Hz
Spec.	X	15W	X	X	15W	←	←	←
Part code	X	3013600010	X	X	3013600000	←	←	←

9. PCB TRANSFORMER

1) FR-540N

Refrigerant	R12, R134a							
Voltage	100V/50,60Hz	110V/60Hz	115, 120V/60Hz	127V/60Hz	220V/50Hz	220V/60Hz	230V/50Hz	240V/50Hz
Part code	X	5EPK057700	X	X	5EPK057609	5EPK042000	5EPK057030	5EPK057630

10. MAIN PCB ASSEMBLY

1) FR-540N

Refrigerant	R12, R134a							
Voltage	100V/50,60Hz	110V/60Hz	115, 120V/60Hz	127V/60Hz	220V/50Hz	220V/60Hz	230V/50Hz	240V/50Hz
Spec.	X	N803	X	X	N803	←	←	←
Part code	X	3014303620	X	X	3014302540	←	←	←

11. DRYER

Refrigerant	R12	R134a
Spec.	10 g	15 g
Part code	3016800103	3016801100

POWER CORD SPECIFICATION

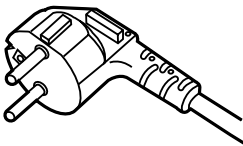
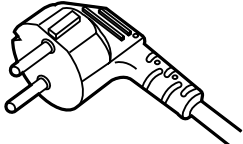
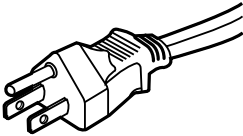
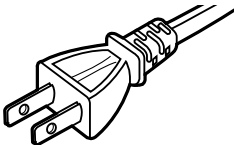
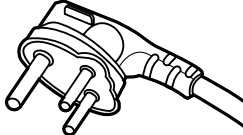
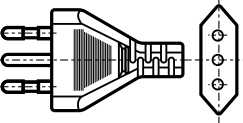
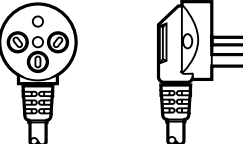
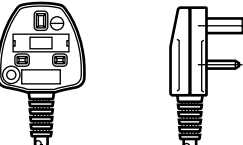
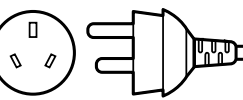
NO	SHAPE OF POWER CODE	PART CODE	DESCRIPTION	REMARK
1		3011315000	CP-2PIN	FOR EUROPEAN COUNTRY
2		401RA17200	CP-2PIN	FOR OTHER COUNTRY
3		4006D17101	KP-30	FOR AMERICA
4		401PD17101	KP-211	FOR JAPAN & TAIWAN
5		3011300801	BP-3PIN	
6		3011303010	#267	FOR CHILE
7		3011315310		FOR ISRAEL
8		3011303050	BS-1363A	FOR U.K, MIDDLE ASIA SINGAPORE & MALAYSIA
9		3011301200	KP-551/550	FOR CHINA & AUSTRALIA

* Upper power cord's part code is only for lead wire, without any kinds of terminal or housing.

9. DOOR COLOR SPECIFICATION

1. FR-540N

1. ASSEMBLY URETHAN FREEZER DOOR

Refrigerant	R12				R134a			
Key type	Dull lamina sheet	High glossy lamina sheet	Normal PCM	High glossy bright PCM	Dull lamina sheet	High glossy lamina sheet	Normal PCM	High glossy bright PCM
Part code	X	PFDT1UJ110	X	X	X	PFDT1UJ115	X	X

2. ASSEMBLY URETHAN REFRIGERATOR DOOR

Refrigerant	R12				R134a			
Color type	Dull lamina sheet	High glossy lamina sheet	Normal PCM	High glossy bright PCM	Dull lamina sheet	High glossy lamina sheet	Normal PCM	High glossy bright PCM
Part code	X	PFDU2UJ110	X	X	X	PFDU2UJ115	X	X

COLOR TABLE

1. PCM type

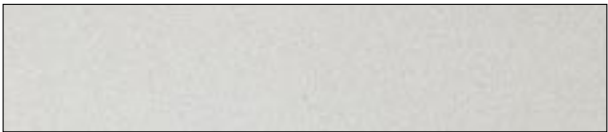
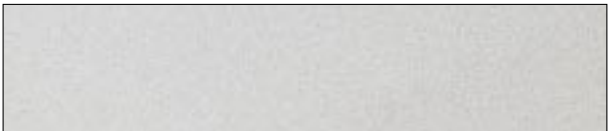
NO	COLOR CHIP	COLOR NAME
1		P/WITH (WH069)
2		'94 L/GRAY (GY158)
3		'95 L/GRAY (GY259)
4		'94 M/GRAY (GY331)
5		'95 M/GRAY (GY335)
6		'97 M/GRAY (GY267)
7		M. D/GRAY (GY750)
8		N/BLUE (BL718)
9		MINT GREEN (GN206)
10		'97 BEIGE (BE215)

2. Lamina sheet type

NO	COLOR CHIP	COLOR NAME
1		P/WITH (WH069)
2		'94 L/GRAY (GY158)
3		'95 L/GRAY (GY259)
4		'94 M/GRAY (GY331)
5		'95 M/GRAY (GY335)
6		'97 M/GRAY (GY267)
7		M. D/GRAY (GY750)
8		N/BLUE (BL718)
9		MINT GREEN (GN206)
10		S/GOLD
11		G/GREEN

10. EXPLODED VIEW AND PARTS LIST

1. FR-540N

1. Exploded view

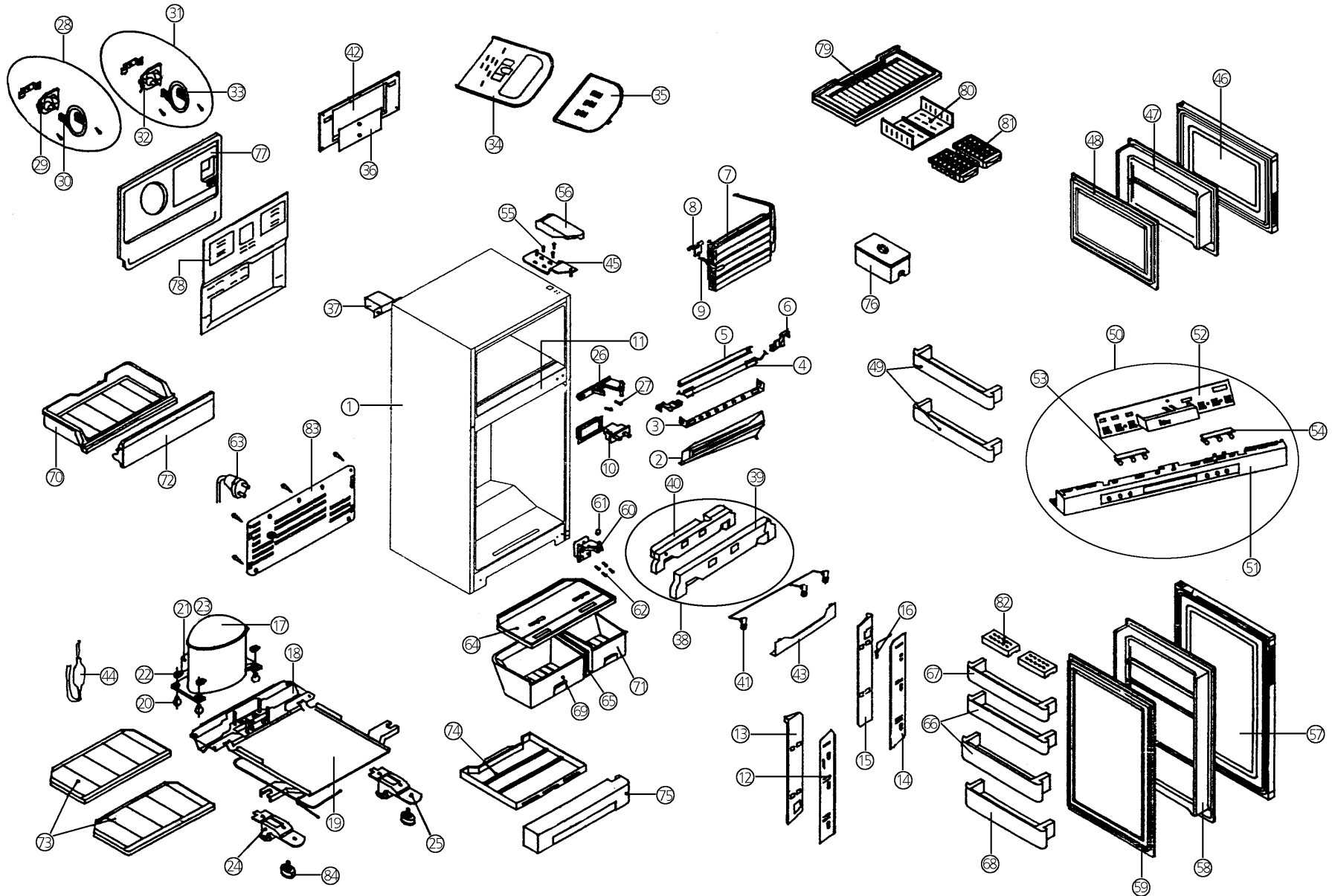

2. Parts list

NO	PART CODE	PART NAME	DESCRIPTION	QUANTITY	REMARK
1		ASSY URT CAB		1	
2	4018G57110	GUIDE DRN *O		1	
3	3011408100	COVER HTR *U		1	
4		HEATER GLAS TUBE AS		1	REFER TO # 10
5	3011408200	COVER HTR *T		1	
6	4010G19010	FIXTURE DEFR HTR		2	
7	3017000701	EVAPORATOR SAS		1	
8	3014801201	SENSOR F D AS	PTC-KD38-FD6 ABS TYPE	1	
9	3017200010	FUSE TEMP AS		1	
10	3018100010	SWITCH DR	DSD-5	1	
11	3014502101	PLATE DV AS		1	
12	3018901902	LOUVER R *S *L	ABS+CERAMIC	1	
13	3013312400	INSULATOR R *S *L	F-PS	1	
14	3018901911	LOUVER R *S *R	ABS +CERMIC	1	
15	3013312410	INSULATOR R *S *R	F-PS	1	
16	3014801001	SENSOR R1 AS		1	
17		COMPRESSOR		1	REFER TO # 9
18	3010302512	BASE COMP SAS		1	
19	3014502304	PLATE AXCON AS		1	
20	3010100201	ABSORBER COMP	NR H=40	4	
21		SWITCH P RELAY AS		1	REFER TO # 9
22	4019H09030	SPECIAL WASHER	SWRH	4	
23	3816100100	RELAY BAND	SK-5 0.7T ZN-3-A	1	
24	3010604802	BRACKET ADJ FT *L AS		1	
25	3010604902	BRACKET ADJ FT *R AS		1	
26	3012900620	HINGE *M AS	D/C	1	
27	3016000220	SPECIAL SCREW	M6 x 16 SWCH22A	2	
28		MOTOR F AS		1	
29		MOTOR F		1	REFER TO # 10
30	3018500100	MOUTH BELL	HIPS	1	
31		MOTOR R AS		1	
32		MOTOR R		1	REFER TO # 10
33	3018500100	MOUTH BELL	HIPS	1	
34	3011406600	COVER F M/F DUCT A	ABS	1	
35	3015500400	WINDOW F	G.E, PC-121R	1	
36		PCB MAIN AS		1	REFER TO # 11
37		TRANS POWER		1	REFER TO # 11
38	3010029791	ASSY CHILD/D		1	
39	3011417901	COVER CHILD/D	HIPS	1	
40	3013312600	INSULATOR CHILD/D		1	
41	3017901311 x	SOCKET R LAMP AS		1	

NO	PART CODE	PART NAME	DESCRIPTION	QUANTITY	REMARK
42	3011410000	COVER M/PCB BOX AS		1	
43	3015501200	WINDOW R	SAN	1	
44		DRYER AS		1	REFER TO # 11
45	3012901400	HINGE *T AS		1	
46		ASSY URT *T DOOR		1	REFER TO # 13
47	3017402202	LINER F DR	ABS 1.4 x 785 x 1140	1	
48	3012300600	GASKET F DR AS	PVC-S	1	
49	3019002100	POCKET F *T	GPPS T3.0	2	
50	3010032020	ASSY FCP		1	
51	3014202610	PANEL F CONTL	ABS T2.3	1	
52	3014303720	PCB *F AS		1	
53	3016300040	BUTTON FCP A	ABS+AL COATING	1	
54	3016300080	BUTTON FCP B	ABS+AL COATING	1	
55	3016001800	SPECIAL BOLT	M6 x L16	4	
56	3011408700	COVER *T HI	PP	1	
57		ASSY URT *U DOOR		1	REFER TO # 13
58	3017402501	LINER R DR	ABS 1.4 x 785 x 1085	1	
59	3012300500	GASKET R DR AS	PVC-S	1	
60	3012900401	HINGE *U AS	MF-ZN5-C	1	
61	7400108511	WASHER PLAIN	PW-1.5T 8.5/20 MFZN	1	
62	3016000600	SPECIAL SCREW	M6 x 20	4	
63		CORD POWER AS		1	REFER TO # 12
64	3011420010	COVER V/CASE AS		1	
65	3014504600	PLATE VEGETB BOX DV	GPPS	1	
66	3019002000	POCKET MULT	GPPS T3.0	2	
67	3019004100	POCKET BOTL A	GPPS	1	
68	3019002600	POCKET BOTL B	GPPS T3.0	1	
69	3010507400	CASE VEGETB *L	GPPS	1	
70	3011102300	CASE CHILD	GPPS T3.5	1	
71	3010507410	CASE VEGETB *R	GPPS	1	
72	3011705620	DOOR CHILD	GPPS	1	
73	3017806800	SHELF R	SAN T3.5	2	
74	4010G30661	BOILD	PP T1.3	1	
75	3011408501	COVER CAB BRKT	ASB	1	
76	3010508401	BOX ICE AS	SAN	1	
77	3013312910	INSULATOR F LUVR AS		1	
78	3018904000	LOUVER F AS		1	
79	3017804700	SHELF F	GPPS	1	
80	3012500510	GUIDE ICING CASE	GPPS	1	
81	3011102100	CASE ICING	PP	2	
82	3011103900	CASE EGG	GP	2	
83	3012400502	GRILLE	PP	1	
84	3010010900	ASSY ADJ FT PAKG		1	

11. ELECTRONIC FUNCTION

1. FR-540N

1) How to use the panel

- The temperature inside the freezer and refrigerator room is controlled automatically according to the customer's purpose of use.
- The temperature inside the freezer and refrigerator room can not be controlled manually. Quick freezing is operative.
- This function continues until the user releases it.

- The comp and fan in the refrigerating room operate for 40 min.
- Quick fridge time appears for the first 5 sec. and then returns to clock time.
- Quick fridge remaining time is shown if the switch is pressed.

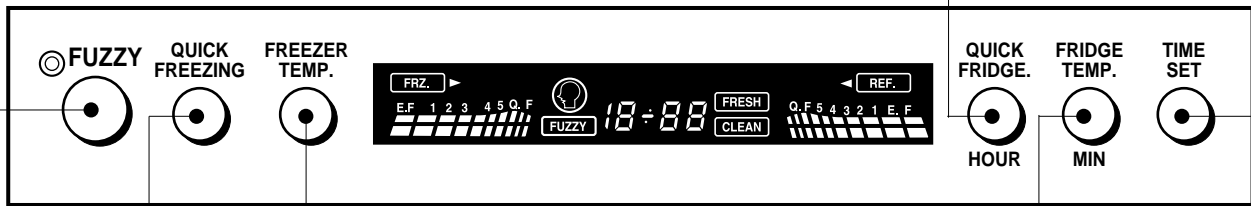

- Freezer Temp. can be controlled by the user.
- Not controllable during "FUZZY" mode.
- Initial mode is "3" and pressing the button changes the temp. range as follows:

→ 3 → 4 → 5 → E.F → 1 → 2





- Fridge Temp. can be controlled easily from outside.
- Not controllable during 'FUZZY' mode.
- Initial mode is "3" and pressing the button changes the temp. range as follows:





→ 3 → 4 → 5 → E.F → 1 → 2



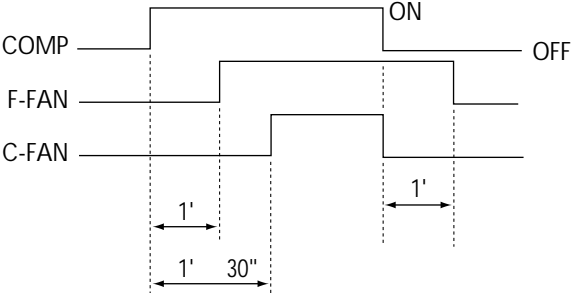

- The comp operates continuously for 150 min. during quick freezing.
- Quick freezing time appears for the first 5 sec and then returns to clock time.
- Quick freezing remaining time is shown if the switch is pressed.

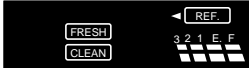

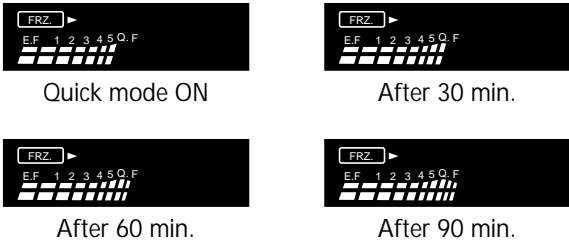

- This button is for setting clock time. "HOUR" and "MIN." can be adjusted at the same time.
- Adjust the time by pressing "HOUR" and "MIN." button.

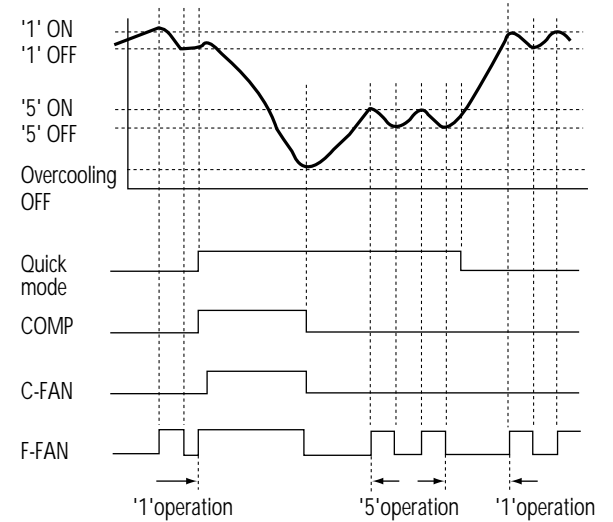
2) Function table

NO.	Control Function	Control Objects	Contents	Remark
1	Initial operation	Time Temperature control	<p>1. In the initial operation, the temperature of FRZ. and REF. automatically set at 3/3.</p> <p>2. The clock is set at 12:00.</p> 	
2	Clock function	LED	<p>1. The time is set at 12:00 in initial operation.</p> <p>2. Time setting</p> <ol style="list-style-type: none"> 1) When the time set button is pressed, the hour/min. indicator blinks with 0.5 sec. interval. 2) Adjust the time with hour button and min. button. 3) If the clock is set to desired time, press the time set button again. 4) If the hour and min. button are not used in 5 sec. during the blink, and then the clock setting function is canceled automatically. 	
3	Freezer temperature control	COMP. F-fan C-fan LED	<p>1. The temperature can be controlled by 6 steps with the freezer temperature button.</p> <p>3 → 4 → 5 → E.F → 1 → 2 → 3</p>  <p>2. The bar LED will indicate according to the freezer temperature button. The bar LED is fully illuminated once and then illuminated up to the each temperature level.</p> <p>3. A single upper bar LED on/off according to the COMP. off/on.</p> <p>COMP ON ▶ </p> <p>COMP OFF ▶ </p>	



NO.	Control Function	Control Objects	Contents	Remark																					
			<p>4. Time chart of each device.</p>  <p>5. COMP. on/off temperature (Temperature °C/Resistance kΩ)</p> <table border="1" data-bbox="604 824 1278 936"> <thead> <tr> <th></th> <th>E.F</th> <th>1</th> <th>2</th> <th>3</th> <th>4</th> <th>5</th> </tr> </thead> <tbody> <tr> <td>COMP. OFF</td> <td>-21/23.6</td> <td>-21/23.6</td> <td>-22/25.0</td> <td>-23/26.4</td> <td>-24/27.9</td> <td>-25/29.6</td> </tr> <tr> <td>COMP.ON</td> <td>-16/17.9</td> <td>-16/17.9</td> <td>-17/18.9</td> <td>-18/20.0</td> <td>-19/21.1</td> <td>-20/22.3</td> </tr> </tbody> </table>		E.F	1	2	3	4	5	COMP. OFF	-21/23.6	-21/23.6	-22/25.0	-23/26.4	-24/27.9	-25/29.6	COMP.ON	-16/17.9	-16/17.9	-17/18.9	-18/20.0	-19/21.1	-20/22.3	
	E.F	1	2	3	4	5																			
COMP. OFF	-21/23.6	-21/23.6	-22/25.0	-23/26.4	-24/27.9	-25/29.6																			
COMP.ON	-16/17.9	-16/17.9	-17/18.9	-18/20.0	-19/21.1	-20/22.3																			
4	Refrigerator temperature control	R-fan LED	<p>1. The temperature can be controlled by 6 steps with the fridge temperature button.</p> <p>3 → 4 → 5 → E.F → 1 → 2 → 3</p>  <p>2. The bar LED will indicate according to the fridge temperature button. The bar LED is fully illuminated once and then illuminated up to the each temperature level.</p> <p>3. A single upper bar LED on/off according to the R-fan off/on.</p> <p>R-FAN ON ► </p> <p>R-FAN OFF ► </p> <p>4. Range of R-fan on/off (Temperature °C/Resistance kΩ)</p> <table border="1" data-bbox="604 1711 1278 1823"> <thead> <tr> <th></th> <th>E.F</th> <th>1</th> <th>2</th> <th>3</th> <th>4</th> <th>5</th> </tr> </thead> <tbody> <tr> <td>R-fan off</td> <td>0.7/29.1</td> <td>0.7/29.1</td> <td>-0.3/30.3</td> <td>-1.3/31.6</td> <td>-2.3/33.2</td> <td>-3.3/34.8</td> </tr> <tr> <td>R-fan on</td> <td>2.05/27.4</td> <td>1.05/28.7</td> <td>0.05/30.0</td> <td>-0.95/31.1</td> <td>-1.95/32.7</td> <td>-2.95/34.2</td> </tr> </tbody> </table> <p>5. In case of D-sensor error, R-fan operation is connected with the COMP.</p> <p>6. When the COMP. is off and the temperature of the D-sensor is above -3°C, the R-fan turns off regardless of the R-sensor.</p> <p>7. The R2-sensor is only used in detecting low cooling.</p>		E.F	1	2	3	4	5	R-fan off	0.7/29.1	0.7/29.1	-0.3/30.3	-1.3/31.6	-2.3/33.2	-3.3/34.8	R-fan on	2.05/27.4	1.05/28.7	0.05/30.0	-0.95/31.1	-1.95/32.7	-2.95/34.2	
	E.F	1	2	3	4	5																			
R-fan off	0.7/29.1	0.7/29.1	-0.3/30.3	-1.3/31.6	-2.3/33.2	-3.3/34.8																			
R-fan on	2.05/27.4	1.05/28.7	0.05/30.0	-0.95/31.1	-1.95/32.7	-2.95/34.2																			



NO.	Control Function	Control Objects	Contents	Remark
5	Quick freezing	COMP. F-fan C-fan LED	<p>1. If quick freezing button is pressed, the clock mode is changed to quick freezing time mode.</p>  <p>2. The bar LED is illuminated 3 times in a row.</p>  <p>3. The COMP., F-fan operate continuously for 150 min.</p> <p>4. If the quick freezing button is pressed during quick freezing mode, the remaining time is indicated on the clock indicator for 5 sec. (After 5 sec. it returns to the current time)</p> <p>5. If press the quick freezing button twice in 5 sec., then quick freezing mode is canceled.</p>	
6	Quick fridge	COMP. F-fan C-fan R-fan LED	<p>1. If press the quick fridge button, the clock mode is changed to quick fridge time mode. (Quick fridge mode is worked for 40 min.)</p>  <p>2. Time chart of the quick fridge mode.</p>  <p>Legend:  : ON  : OFF</p>	

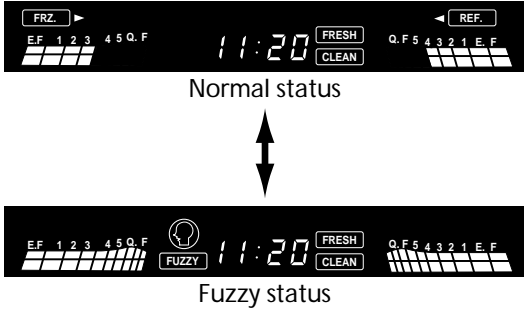

NO.	Control Function	Control Objects	Contents	Remark																								
			<p>3. The bar LED is illuminated 3 times in a row.</p> <div style="display: flex; justify-content: space-around;"> <div style="text-align: center;">  <p>Quick mode ON</p> </div> <div style="text-align: center;">  <p>After 30 min.</p> </div> </div> <div style="display: flex; justify-content: space-around; margin-top: 10px;"> <div style="text-align: center;">  <p>After 60 min.</p> </div> <div style="text-align: center;">  <p>After 90 min.</p> </div> </div> <p>4. If the quick fridge button is pressed during the quick fridge mode, then remaining time is indicated on the clock indicator for 5 sec. (After 5sec., it returns to the current time.)</p> <p>5. If press the quick fridge button twice in 5 sec. then quick fridge mode is canceled.</p>																									
7	Fuzzy	COMP. Fan C-fan R-fan LED	<p>1. If the fuzzy button is pressed, the fuzzy indicator is illuminated and the FRZ. and REF. indicator is turned off.</p>  <p>2. The bar LED is fully illuminated twice in a row, and then it is illuminated according to the temperature range.</p> <p>3. If the fuzzy button is pressed again, the fuzzy function is canceled. At the same time, the freezer and fridge temperature level is set 3/3.</p> <p>4. Control the freezer and fridge temperature during the fuzzy function.</p> <p>1) After the power is loaded, accumulated door (freezer and fridge door) open time is recorded every 2 hours for 24 hours. ◆ The data are recorded until the power is off.</p> <p>2) Averaged data are classified according to following table.</p> <table border="1" data-bbox="604 1565 1281 1715"> <thead> <tr> <th>Accumulated door open time</th> <th>Data classification</th> <th>Remark</th> </tr> </thead> <tbody> <tr> <td>Below 30 sec.</td> <td>MIN. unit(good condition)</td> <td>Rarely opened</td> </tr> <tr> <td>30 sec.-3 min.</td> <td>MID. unit</td> <td></td> </tr> <tr> <td>Above 3 min.</td> <td>MAX. unit (bad condition)</td> <td>Frequently opened</td> </tr> </tbody> </table> <p>3) In fuzzy function, it operates by predicting the condition in 2 hours with above data.</p> <table border="1" data-bbox="604 1803 1281 2013"> <thead> <tr> <th>Data classification</th> <th>Freezer/Fridge temperature</th> <th>Remark</th> </tr> </thead> <tbody> <tr> <td>MIN. unit</td> <td>2/3</td> <td>'3' when outside temperature is above 26°C</td> </tr> <tr> <td>MID. unit</td> <td>3</td> <td></td> </tr> <tr> <td>MAX. unit</td> <td>3/5</td> <td>'3' when outside temperature is below 14°C</td> </tr> </tbody> </table>	Accumulated door open time	Data classification	Remark	Below 30 sec.	MIN. unit(good condition)	Rarely opened	30 sec.-3 min.	MID. unit		Above 3 min.	MAX. unit (bad condition)	Frequently opened	Data classification	Freezer/Fridge temperature	Remark	MIN. unit	2/3	'3' when outside temperature is above 26°C	MID. unit	3		MAX. unit	3/5	'3' when outside temperature is below 14°C	In fuzzy mode, quick mode is operative.
Accumulated door open time	Data classification	Remark																										
Below 30 sec.	MIN. unit(good condition)	Rarely opened																										
30 sec.-3 min.	MID. unit																											
Above 3 min.	MAX. unit (bad condition)	Frequently opened																										
Data classification	Freezer/Fridge temperature	Remark																										
MIN. unit	2/3	'3' when outside temperature is above 26°C																										
MID. unit	3																											
MAX. unit	3/5	'3' when outside temperature is below 14°C																										

NO.	Control Function	Control Objects	Contents	Remark																																				
8	Determination of defrost		<p>1. Defrost function is started by the following 4 conditions.</p> <p>Condition 1 : Accumulated COMP. on time (MAX. and MIN. time)</p> <p>Condition 2 : Accumulated door open time (different from the accumulated door open time in fuzzy function)</p> <p>Condition 3 : COMP. operation ratio (calculated by the time divided by 150 min. after defrost)</p> <p>Condition 4 : The door open data every 2 hours interval same as fuzzy function</p> <p>2. Method of determination defrost</p> <div data-bbox="608 804 1281 960" style="border: 1px solid black; padding: 5px; margin: 10px 0;"> </div> <p>ϕ..Order of judgement</p> <ol style="list-style-type: none"> 1) In [C], it goes directly to defrost mode if the COMP. operation ratio from [B] to [C] is over 80%. 2) In [D], it goes directly to defrost mode if the COMP. operation ratio from [B] to [D] is over 80%. 3) In [E], it enters to defrost mode unconditionally. 																																					
9	Defrost function	COMP. F-fan C-fan R-fan Heater	<p>1. Defrost step</p> <table border="1" data-bbox="608 1323 1281 1928"> <thead> <tr> <th></th> <th>Pre-cool</th> <th>R-fan defrost</th> <th>D-heater defrost</th> <th>Pause</th> <th>Fan delay</th> </tr> </thead> <tbody> <tr> <td>COMP.</td> <td>on</td> <td>off</td> <td>off</td> <td>off</td> <td>on</td> </tr> <tr> <td>F-fan</td> <td>on</td> <td>off</td> <td>off</td> <td>off</td> <td>off</td> </tr> <tr> <td>R-fan</td> <td>on</td> <td>on</td> <td>off</td> <td>off</td> <td>off</td> </tr> <tr> <td>D-heater</td> <td>off</td> <td>off</td> <td>on</td> <td>off</td> <td>off</td> </tr> <tr> <td></td> <td> ⚡Time : 30 min. ⚡Quick mode is prior </td> <td> ⚡Time : 10 min. ⚡Regardless of door open ⚡If D-sensor temperature is over 10°C, R-fan goes off and it skips to pause step. ⚡Defrost is prior </td> <td> ⚡Time : 90 min. ⚡If D-sensor temperature is over 10°C, D-heater goes off. ⚡If D-sensor is in error, it is on for 45 min. unconditionally ⚡Defrost is prior </td> <td> ⚡Time : 7 min. ⚡Defrost is prior </td> <td> ⚡Time : 5 min. ⚡Defrost is prior </td> </tr> </tbody> </table>		Pre-cool	R-fan defrost	D-heater defrost	Pause	Fan delay	COMP.	on	off	off	off	on	F-fan	on	off	off	off	off	R-fan	on	on	off	off	off	D-heater	off	off	on	off	off		⚡Time : 30 min. ⚡Quick mode is prior	⚡Time : 10 min. ⚡Regardless of door open ⚡If D-sensor temperature is over 10°C, R-fan goes off and it skips to pause step. ⚡Defrost is prior	⚡Time : 90 min. ⚡If D-sensor temperature is over 10°C, D-heater goes off. ⚡If D-sensor is in error, it is on for 45 min. unconditionally ⚡Defrost is prior	⚡Time : 7 min. ⚡Defrost is prior	⚡Time : 5 min. ⚡Defrost is prior	
	Pre-cool	R-fan defrost	D-heater defrost	Pause	Fan delay																																			
COMP.	on	off	off	off	on																																			
F-fan	on	off	off	off	off																																			
R-fan	on	on	off	off	off																																			
D-heater	off	off	on	off	off																																			
	⚡Time : 30 min. ⚡Quick mode is prior	⚡Time : 10 min. ⚡Regardless of door open ⚡If D-sensor temperature is over 10°C, R-fan goes off and it skips to pause step. ⚡Defrost is prior	⚡Time : 90 min. ⚡If D-sensor temperature is over 10°C, D-heater goes off. ⚡If D-sensor is in error, it is on for 45 min. unconditionally ⚡Defrost is prior	⚡Time : 7 min. ⚡Defrost is prior	⚡Time : 5 min. ⚡Defrost is prior																																			

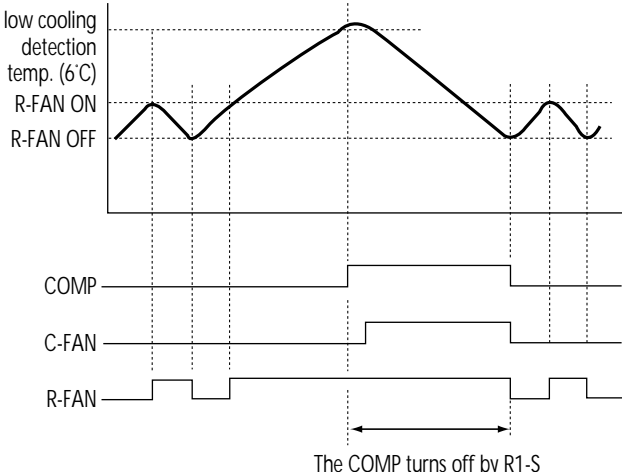
NO.	Control Function	Control Objects	Contents	Remark
			<pre> graph TD Start([Deciding defrosting period]) --> Q1{Is it min. accumulated COMP ON time?} Q1 -- NO --> Start Q1 -- YES --> Q2{Is the percentage of operation, so far, above 80%?} Q2 -- NO --> Q3{Is it max. accumulated COMP ON time?} Q3 -- YES --> Q1 Q3 -- NO --> Q4{Is the resuting accumulated door open time, 10 min?} Q4 -- NO --> Start Q4 -- YES --> Q5{Is the percentage of operation, so far, above 80%?} Q5 -- YES --> Q1 Q5 -- NO --> Q6{Will it be min. door open time in 6 hours?} Q6 -- YES --> Q7{Is it max. accumulated door open time?} Q7 -- YES --> Q1 Q7 -- NO --> Start Q6 -- NO --> Start </pre>	
10	Forced defrost	COMP. F-fan R-fan C-fan Heater	<p>1. When press freezer temperature button, press quick freezing button 5 times. Then start forced defrost function.</p> <p>2. Forced defrost function starts from the D-heater step without Pre-cool and R-fan defrost step.</p> <p>3. Control method of each device is same as in defrosting mode.</p> <p>4. After forced defrost, the normal defrost is enabled in 14 hours of accumulated COMP. on time.</p>	

NO.	Control Function	Control Objects	Contents	Remark									
11	Device test function	COMP. F-fan R-fan Heater	<p>1. Pressing the SW01 on M-PCB enables device test function.</p> <p>2. Pressing the SW01 proceeds the operation of device as follows.</p> <p style="padding-left: 40px;">COMP. → D-heater → break → F-fan → R-fan → return</p> <p>3. Each device is on for 1 min. and returns to be off.</p> <p>4. During device test function, all custom LED of F-PCB is illuminated.</p> <p>◆ Custom LED check function</p>										
12	Demo function	F-fan R-fan LED	<p>1. If the CN10 of M-PCB is shorted, it changes to demo function.</p> <p>2. F-PCB indicates the normal status and fuzzy status alternately in 15 sec. intervals.</p> <div style="text-align: center;">  <p>Normal status</p> <p>↕</p> <p>Fuzzy status</p> </div> <p>3. F-fan and R-fan operation is same as below</p> <table border="1" data-bbox="608 1272 1284 1525"> <thead> <tr> <th></th> <th>Normal status</th> <th>Demo status</th> </tr> </thead> <tbody> <tr> <td>Door open</td> <td>OFF F-fan and R-fan is off at the same time.</td> <td>ON F-fan and R-fan is on at the same time</td> </tr> <tr> <td>Door close</td> <td>ON F-fan : ON after 2 sec. R-fan : ON after 1 sec.</td> <td>OFF F-fan : OFF after 2 sec. R-fan : OFF after 1 sec.</td> </tr> </tbody> </table>		Normal status	Demo status	Door open	OFF F-fan and R-fan is off at the same time.	ON F-fan and R-fan is on at the same time	Door close	ON F-fan : ON after 2 sec. R-fan : ON after 1 sec.	OFF F-fan : OFF after 2 sec. R-fan : OFF after 1 sec.	
	Normal status	Demo status											
Door open	OFF F-fan and R-fan is off at the same time.	ON F-fan and R-fan is on at the same time											
Door close	ON F-fan : ON after 2 sec. R-fan : ON after 1 sec.	OFF F-fan : OFF after 2 sec. R-fan : OFF after 1 sec.											
13	Delivery function	COMP. F-fan R-fan LED	<p>1. This function operates when fridge temperature and quick fridge button are pressed, and plug the power code.</p> <div style="text-align: center;">  </div> <p>2. At this time, the custom LED is normal and all devices are off.</p> <p>3. After 10 min., all devices operate normally.</p>										

NO.	Control Function	Control Objects	Contents	Remark
14	Low cooling prevent function	COMP. R-fan	<p>1. The low cooling prevention function will be operating if the temperature of R1-sensor or R2-sensor goes above 6°C.</p> <p>2. Time chart</p>  <p>3. R1 and R2-sensor detects the low cooling prevention function, but only R1-sensor returns the normal function.</p>	
15	COMP. restart prevent	COMP.	<p>1. The COMP. can not be on within 6 min. after COMP. off.</p> <p>2. During Pre-cool step in defrost mode. 6 min. delay is unavailable.</p>	
16	Error display	LED	<p>1. Press the quick freezing button 3 times when press the quick fridge and fridge temperature button.</p>  <p>2. If press the freezer temperature button, then stage changed like follow. R1-sensor temperature → D-sensor temperature → F-sensor temperature → Error code</p> <p>3. Auto return to the normal time is 8 min. without pressing the freezer temperature button.</p>	

NO.	Control Function	Control Objects	Contents	Remark
			<p>4. Sensor's temperature indication is as follow.</p> <p>1) R-sensor (when 1°C)</p>  <p>2) D-sensor (when -23°C)</p>  <p>3) F-sensor (when -18°C)</p>  <p>5. Error code is referred to 3) Self-diagnosis table</p>	
17	Alarm function	Buzzer	<ol style="list-style-type: none"> 1. Alarm buzzes 1 sec. after 3 sec. of initial power on. 2. Alarm buzzes whenever each switch in F-PCB is pressed. 3. If the door is opened for more than 1 min., chirpy sound alarm buzzes. 	

3) Self-diagnosis table

Code	Content	Perception method	Refrigerator operation state
F 1	F-sensor malfunction	<ul style="list-style-type: none"> - Short circuit - Wire disconnection 	<ul style="list-style-type: none"> - The refrigerator is run at 60% power with a 40 minute period. - When the refrigerator compartment is over frosted, the operation is forcibly stopped, then returns to a 40 minute period operation.
R T	RT-sensor malfunction	<ul style="list-style-type: none"> - Short circuit - Wire disconnection 	<ul style="list-style-type: none"> - In fuzzy mode, control temperature according to the outside temperature is disable.
R 1	R1-sensor malfunction	<ul style="list-style-type: none"> - Short circuit - Wire disconnection 	<ul style="list-style-type: none"> - Operated by R2-sensor
R 2	R2-sensor malfunction	<ul style="list-style-type: none"> - Short circuit - Wire disconnection 	<ul style="list-style-type: none"> - Low cooling prevention function by R2-sensor is disable.
D 1	D-sensor malfunction	<ul style="list-style-type: none"> - Short circuit - Wire disconnection - When the D-sensor temperature is over -5°C while the compressor is off. 	<ul style="list-style-type: none"> - Heater turns on for 45 minutes irrespective of D-sensor - R-fan can be on/off by R1-sensor only when compressor on.
D 0	Door switch malfunction	<ul style="list-style-type: none"> - When the door switch is left open continually for an hour. 	<ul style="list-style-type: none"> - The R-fan and F-fan operates irrespective of the door switch when the compressor is on.
F 3	Defrost malfunction	<ul style="list-style-type: none"> - When the D-sensor turns off not by 13°C but by a 90 minutes period while the heater is on. 	<ul style="list-style-type: none"> - Normal operation.
C 1	Cycle malfunction Compressor malfunction	<ul style="list-style-type: none"> - When the temperature of the D-sensor is over -5°C although the compressor has been running for 3 hours non-stop. 	<ul style="list-style-type: none"> - Normal operation.

◆ All error code will be reset, if they become normal.

4) Circuit and Wiring Diagram N802

