

S/M No. : FR09100010

DAEWOO

Service Manual

Refrigerator

Model: FR-091



DAEWOO ELECTRONICS CO., LTD.

CONTENTS

1. Specification	1
2. External view	2
3. Wire diagram	3
4. Name of parts.....	4
5. Refrigerant cycle diagram	5
6. Machine room view and part list.....	6
7. Main components	7
8. Door color specification	9
9. Exploded view and parts list	12

1. SPECIFICATION

MODEL NAME		FR-091
Refrigerant	R12	95g
	R134a	90g
Cooling System		Aluminumembossed Plat "Roll Bond" Type
Refrigeration System		Natural Cold-air Convection
Defrost System		Natural
Defrost Operation		Manual Start & Stop
Cold Control		Adjustable Dial
Capacity	Freezer	-
	Refrigerator	-
	Total	75 ℓ
External Dimension	Height	726mm
	Width	440mm
	Depth	452mm
Net Weight		21Kg

2. EXTERNAL VIEW

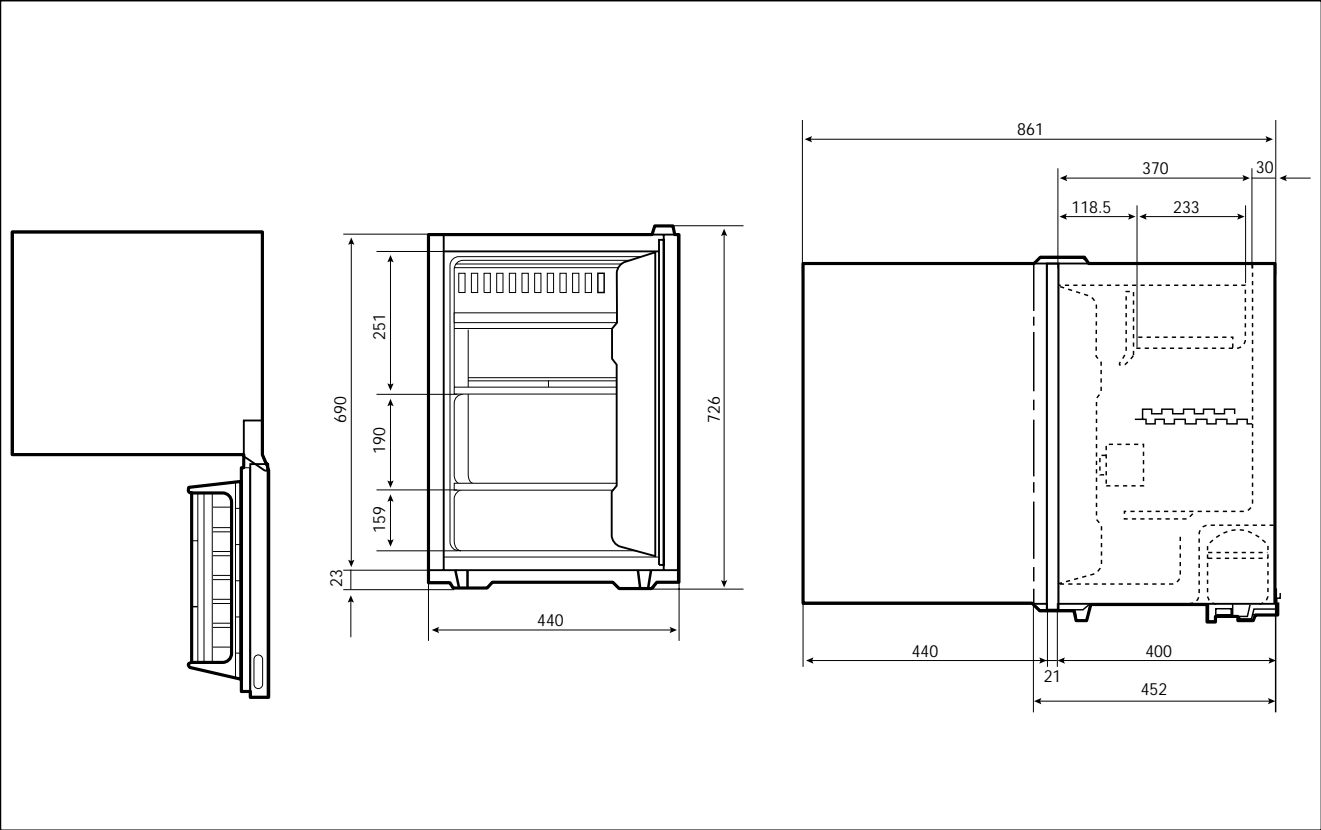

3. WIRE DIAGRAM

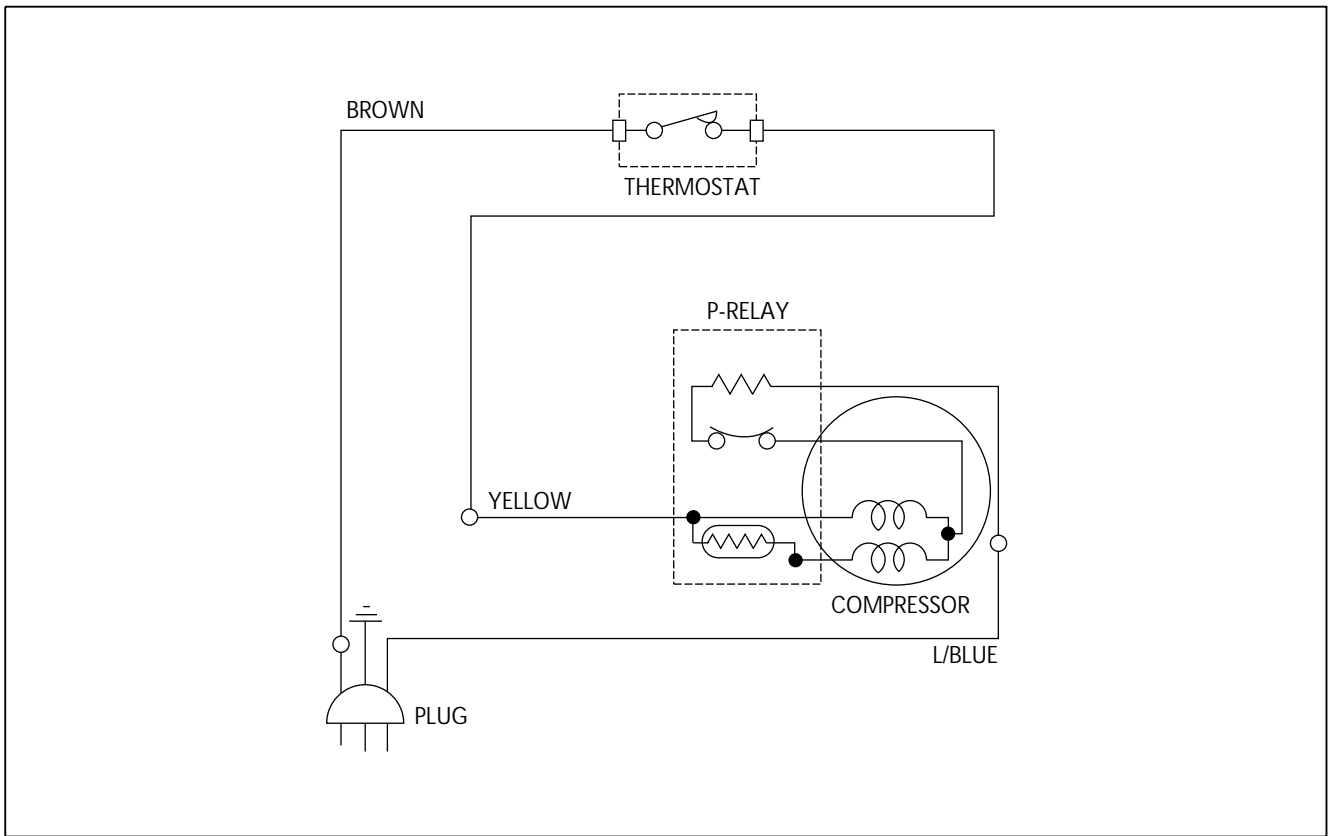

4. NAME OF PARTS

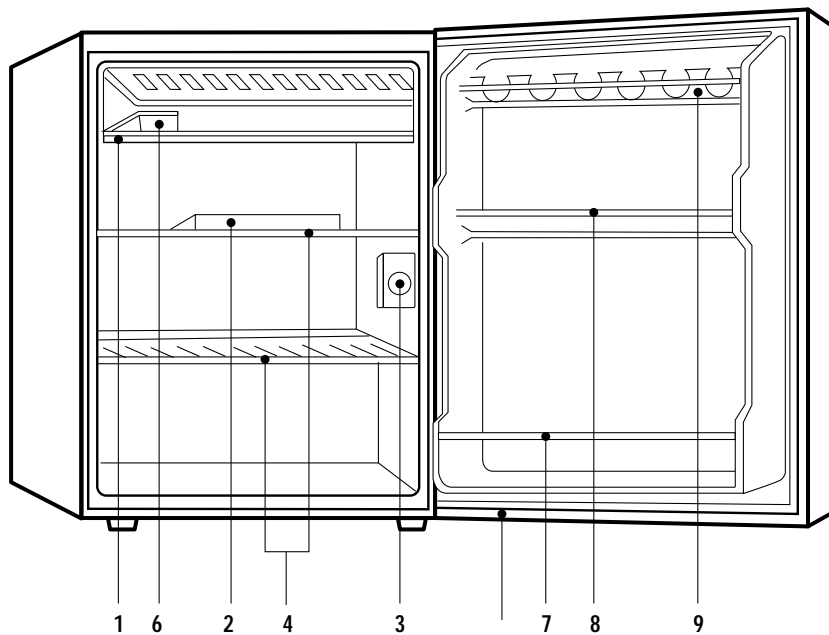

- 1 Evaporator
- 2 Drain Pan
- 3 Control Box
- 4 Plastic Coated Shelf
- 5 Magnetic Door Seals
- 6 Ice Tray
- 7 Bottle Rack
- 8 Usable Rack
- 9 Egg Shelf

5. REFRIGERANT CYCLE DIAGRAM

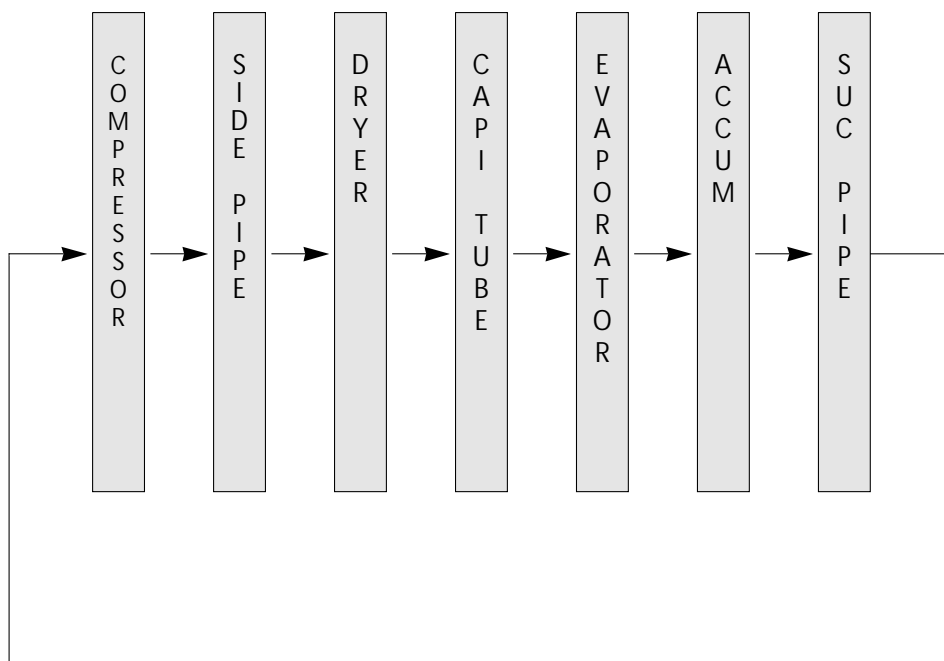
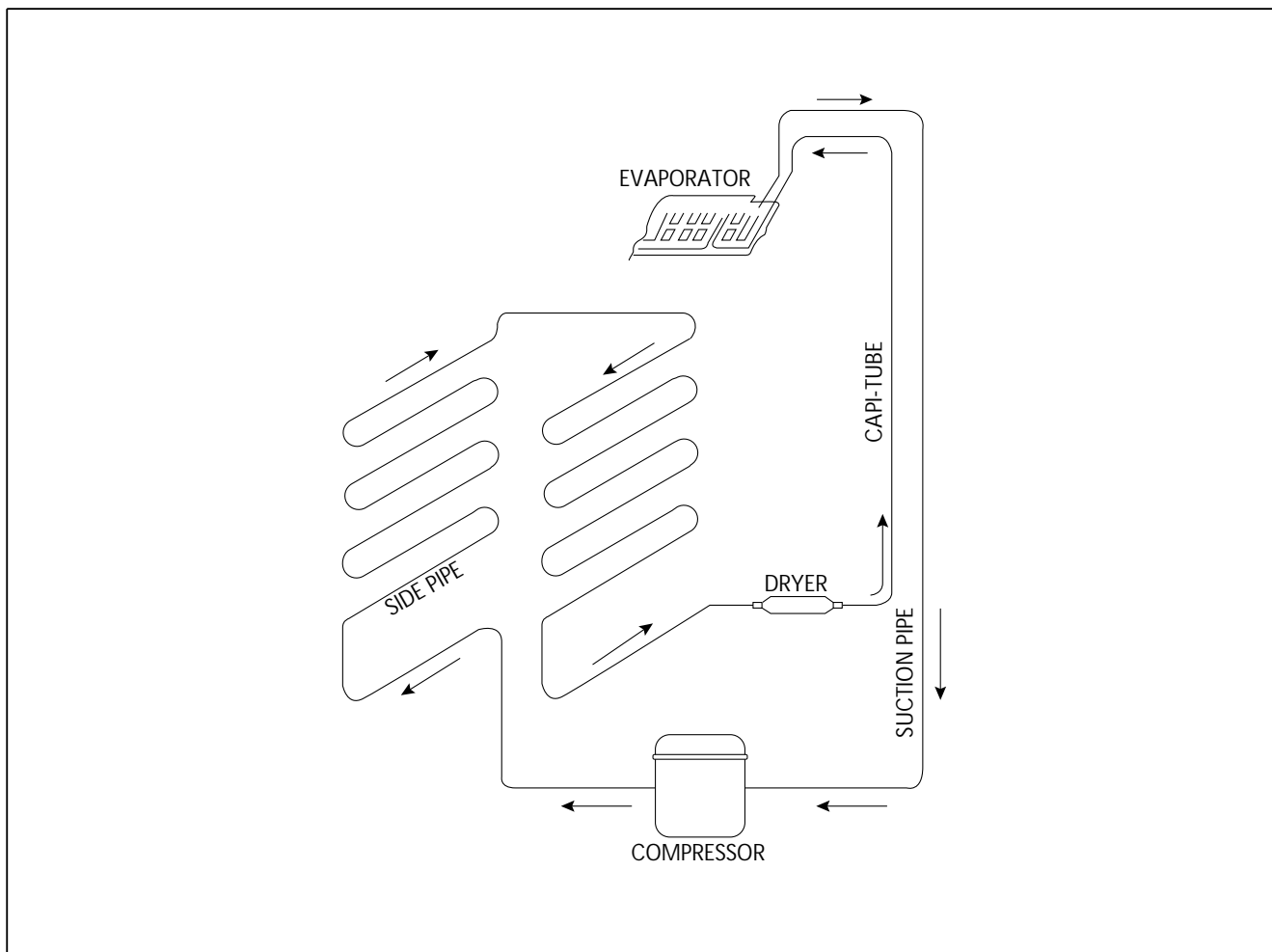

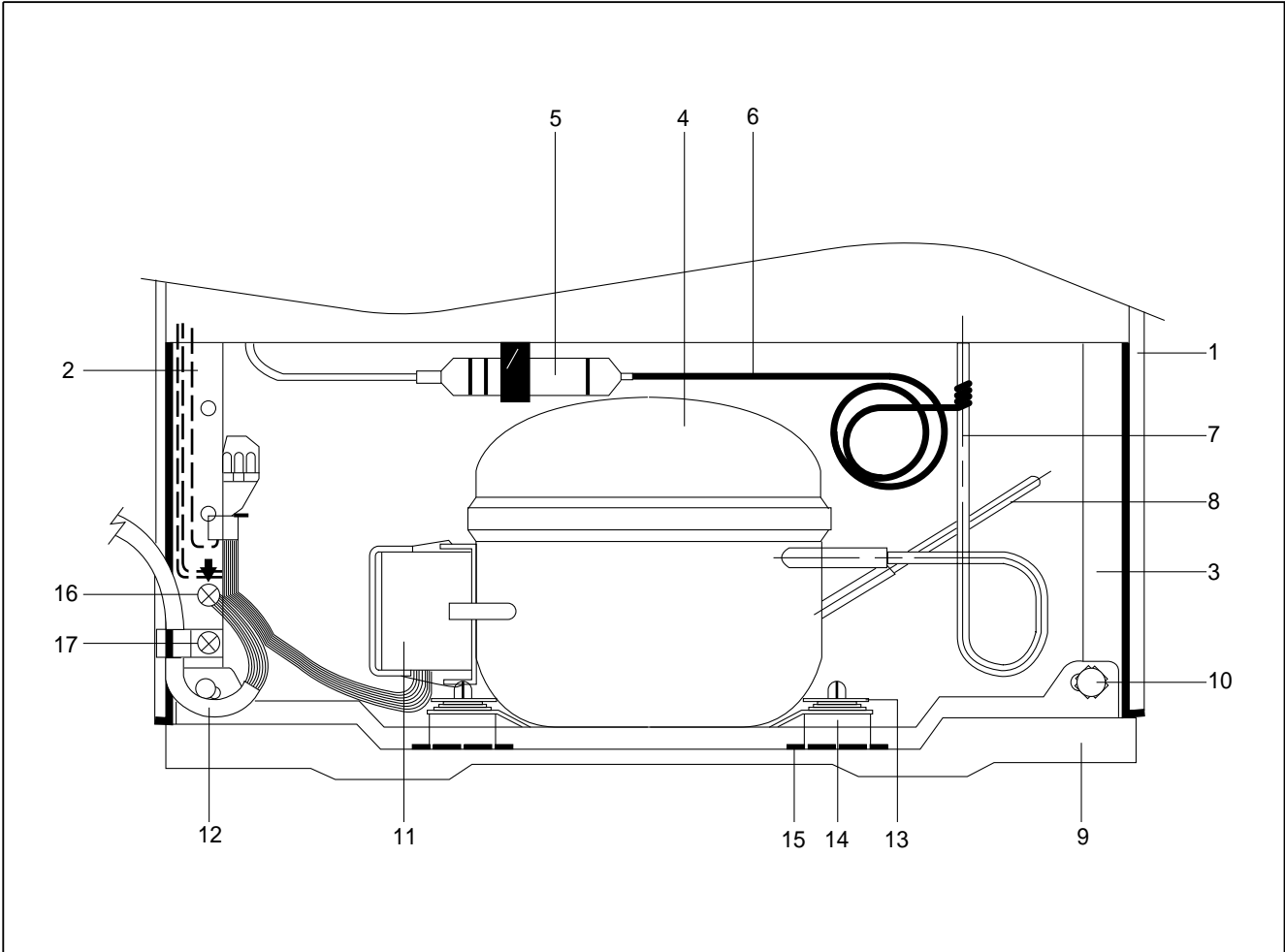

NO	PART NAME	NO	PART NAME	NO	PART NAME
1	CABINET	7	SUCTION PIPE	13	WASHER *T
2	REINFORCE *L	8	PIPE CON	14	ABSORBER
3	REINFORCE *R	9	BASE COMP	15	WASHER *U
4	COMPRESSOR	10	BOLT HEX	16	MACHINE SCREW
5	DRYER	11	P RELAY AS	17	TAPPING SCREW
6	CAPI TUBE	12	POWER CORD		

7. MAIN COMPONENTS

1. COMPRESSOR

Refrigerant	R12							
Voltage	100V/50,60Hz	110V/60Hz	115, 120V/60Hz	127V/60Hz	220V/50Hz	220V/60Hz	230V/50Hz	240V/50Hz
Comp. model	FL7Y-1	FL5Y-1U	←	←	SL7Y-5	←	←	←
Part code	3951105400	39511054U0	←	←	3954105470	←	←	←
Strating type	RSIR	←	←	←	RSIR	←	←	←

Refrigerant	R134a							
Voltage	100V/50,60Hz	110V/60Hz	115, 120V/60Hz	127V/60Hz	220V/50Hz	220V/60Hz	230V/50Hz	240V/50Hz
Comp. model	HFL7Y	HFL5Y-1H	←	X	HSL7Y-5	X	HSL7Y-5	←
Part code	3951107F00	3951105F10	←	X	3954107F50	X	3954107F50	←
Strating type	RSIR	←	←	X	RSIR	X	RSIR	←

2. RELAY ASSEMBLY

Refrigerant	R12							
Voltage	100V/50,60Hz	110V/60Hz	115, 120V/60Hz	127V/60Hz	220V/50Hz	220V/60Hz	230V/50Hz	240V/50Hz
Relay model	213THB, S068	197SHB, S068	←	←	129SHB, S220	104NHB, S220	129SHB, S220	←
Part code	3018101910	3018102010	3018102110	3018101410	3018100110	3018106810	3018101710	←

Refrigerant	R134a							
Voltage	100V/50,60Hz	110V/60Hz	115, 120V/60Hz	127V/60Hz	220V/50Hz	220V/60Hz	230V/50Hz	240V/50Hz
Relay model	265THB, S068	174SHB, S068	174SHB, S068	X	129SHB, S220	X	129SHB, S220	←
Part code	3018101920	3018108020	3018102120	X	3018101940	X	3018101940	←

3. CONTROL SWITCH



Refrigerant	R12							
Voltage	100V/50,60Hz	110V/60Hz	115, 120V/60Hz	127V/60Hz	220V/50Hz	220V/60Hz	230V/50Hz	240V/50Hz
Spec.	PFN-110U-02A	←	←	←	PFN-110U-02A	←	←	←
Part code	4004V70142	←	←	←	4004V70142	←	←	←

Refrigerant	R134a							
Voltage	100V/50,60Hz	110V/60Hz	115, 120V/60Hz	127V/60Hz	220V/50Hz	220V/60Hz	230V/50Hz	240V/50Hz
Spec.	PFN-110U-02A	PFN-110U-02D	←	PFN-110U-02D	PFN-110U-02A	←	PFN-110U-02A	←
Part code	4004V70142	3018301000	←	4004V70142	4004V70142	←	4004V70142	←

4. DRYER

Refrigerant	R12	R134a
Spec.	5 g	10 g
Part code	4019L04000	3016801300

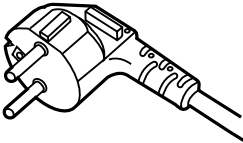
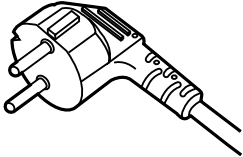
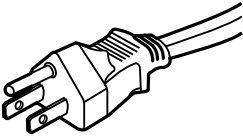
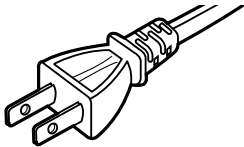
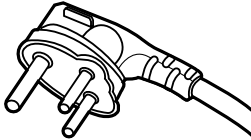
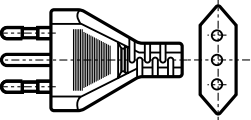
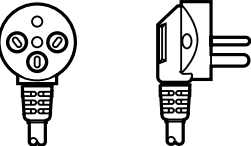
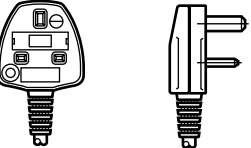
POWER CORD SPECIFICATION

NO	SHAPE OF POWER CODE	PART CODE	DESCRIPTION	REMARK
1		3011315000	CP-2PIN	FOR EUROPEAN COUNTRY
2		401RA17200	CP-2PIN	FOR OTHER COUNTRY
3		4006D17101	KP-30	FOR AMERICA
4		401PD17101	KP-211	FOR JAPAN & TAIWAN
5		3011300801	BP-3PIN	
6		3011303010	#267	FOR CHILE
7		3011315310		FOR ISRAEL
8		3011303050	BS-1363A	FOR U.K, MIDDLE ASIA SINGAPORE & MALAYSIA
9		3011301200	KP-551/550	FOR CHINA & AUSTRALIA

* Upper power cord's part code is only for lead wire, without any kinds of terminal or housing.

8. DOOR COLOR SPECIFICATION

1. ASSEMBLY URETHAN DOOR

1) Key type

Refrigerant	R12				R134a			
Color type	Dull lamina sheet	High glossy lamina sheet	Normal PCM	High glossy bright PCM	Dull lamina sheet	High glossy lamina sheet	Normal PCM	High glossy bright PCM
Part code	X	X	PFUD2UB150	X	X	X	PFUD2UB155	X

2) Non key type

Refrigerant	R12				R134a			
Color type	Dull lamina sheet	High glossy lamina sheet	Normal PCM	High glossy bright PCM	Dull lamina sheet	High glossy lamina sheet	Normal PCM	High glossy bright PCM
Part code	X	PFUD2UB130	PFUD2UB170	X	X	PFUD2UB135	PFUD2UB175	X

COLOR TABLE

1. PCM type

NO	COLOR CHIP	COLOR NAME
1		P/WITH (WH069)
2		'94 L/GRAY (GY158)
3		'95 L/GRAY (GY259)
4		'94 M/GRAY (GY331)
5		'95 M/GRAY (GY335)
6		'97 M/GRAY (GY267)
7		M. D/GRAY (GY750)
8		N/BUE (BL718)
9		MINT GREEN (GN206)
10		'97 BEIGE (BE215)

2. Lamina sheet type

NO	COLOR CHIP	COLOR NAME
1		P/WITH (WH069)
2		'94 L/GRAY (GY158)
3		'95 L/GRAY (GY259)
4		'94 M/GRAY (GY331)
5		'95 M/GRAY (GY335)
6		'97 M/GRAY (GY267)
7		M. D/GRAY (GY750)
8		N/BLUE (BL718)
9		MINT GREEN (GN206)
10		S/GOLD
11		G/GREEN

9. EXPLODED VIEW AND PARTS LIST

1. Exploded view

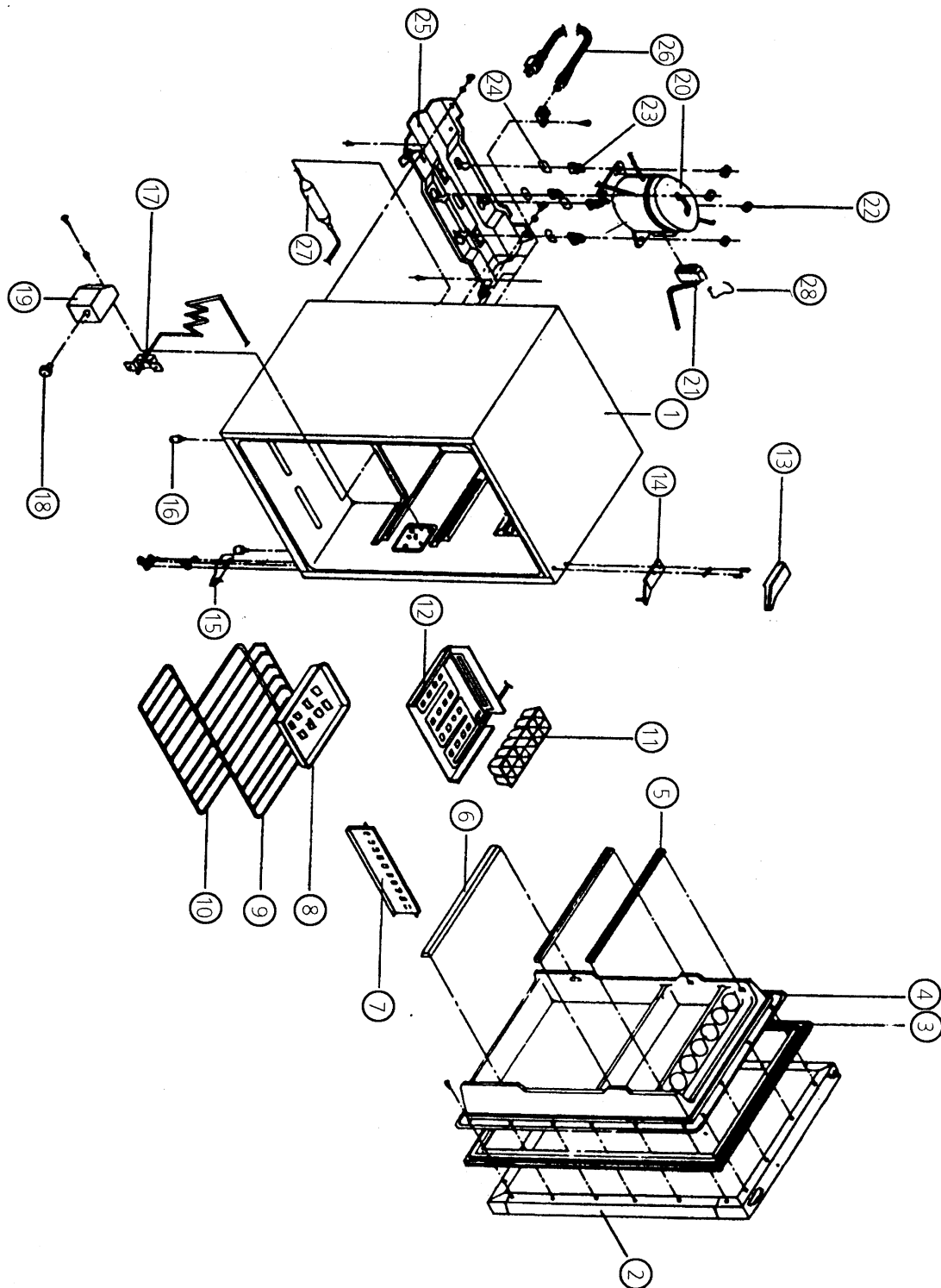

2. Parts list

NO	PART CODE	PART NAME	DESCRIPTION	QUANTITY	REMARK
1		ASSY URT CAB		1	
2		ASSY URT DOOR		1	REFER TO # 9
3	3012302622	GASKET AS	ROUND DOOR	1	
4	3017405600	LINER DR	ABS 1.4 X 715 X 953	1	
5	4016V45010	POCKET A	PVC	2	
6	4016V45020	POCKET B	PVC	1	
7	4016V53212	DOOR F	HIPS	1	
8	3011110100	DRAIN PAN	PE	1	
9	4016V55112	SHELF *T	SWRM-B PE-COATING	1	
10	4016V55212	SHELF *U	SWRM-B PE-COATING	1	
11	4002A30420	CASE ICING	PE-HD	1	
12	4016V0310C	EVAPORATOR AS		1	
13	3011420050	COVER *T HI	PP	1	
14	3012903670	HINGE *T AS	SPHC T2.3	1	
15	3012903900	HINGE *U AS		1	
16	4017L32521	ADJ FOOT *L	PP (JI-360)	2	
17	4004V70142	CS(THERMOSTAT)	PFN 110U-02A	1	
18	3013400300	KNOB AS	ABS	1	
19	3010502900	BOX CONTROL	HIPS	1	
20		COMPRESSOR		1	REFER TO # 7
21		SWITCH P RELAY ASSY		1	REFER TO # 7
22	4001E09030	WASHER COMP	SPG T1.0	4	
23	4001E09013	ABSORBER COMP	NR-A	4	
24	4001E09021	WASHER COMP	SPG T0.6	4	
25	3010301003	BASE COMP	SPG T0.8 X 216 X 434	1	
26		POWER CORD AS		1	REFER TO # 8
27		DRYER		1	REFER TO # 7
28	3816100100	RELAY BAND	SK-5	1	