

**DAEWOO**

# Service Manual

Refrigerator

**MODEL : FR-063R**

✓ **Caution :**

In this Manual, some parts can be changed for improving, their performance without notice in the parts list. So, if you need the latest parts information, please refer to PPL(Parts Price List) in Service Information Center (<http://svc.dwe.co.kr>).

**DAEWOO ELECTRONICS Corp.**

<http://svc.dwe.co.kr>

Mar. 2004

---

---

## CONTENTS

---

---

1. SPECIFICATION .....	2
2. EXTERNAL VIEW .....	3
3. WIRE DIAGRAM .....	4
4. NAME OF PARTS.....	5
5. REFRIGERANT CYCLE DIAGRAM .....	6
6. MACHINE ROOM VIEW AND PARTS LIST .....	7
7. MAIN COMPONENTS .....	8
8. DOOR COLOR SPECIFICATION .....	9
9. EXPLODED VIEW AND PARTSLIST .....	13

# SPECIFICATION

MODEL NAME		FR-063R
Refrigerant	R12	50g
	R134a	55g
Cooling System		Aluminum-embossed Plat i Roll Bondi type
Refrigeration System		Natural Cold-air Convention
Defrost System		Natural
Defrost Operation		Manual start & Stop
Cold Control		Adjustable Dial
Capacity	Freezer	-
	Refrigerator	-
	Total	45 l
External Dimension	Height	511 mm
	Width	440 mm
	depth	452 mm
Net Weight		16 kg

# EXTERNAL VIEW

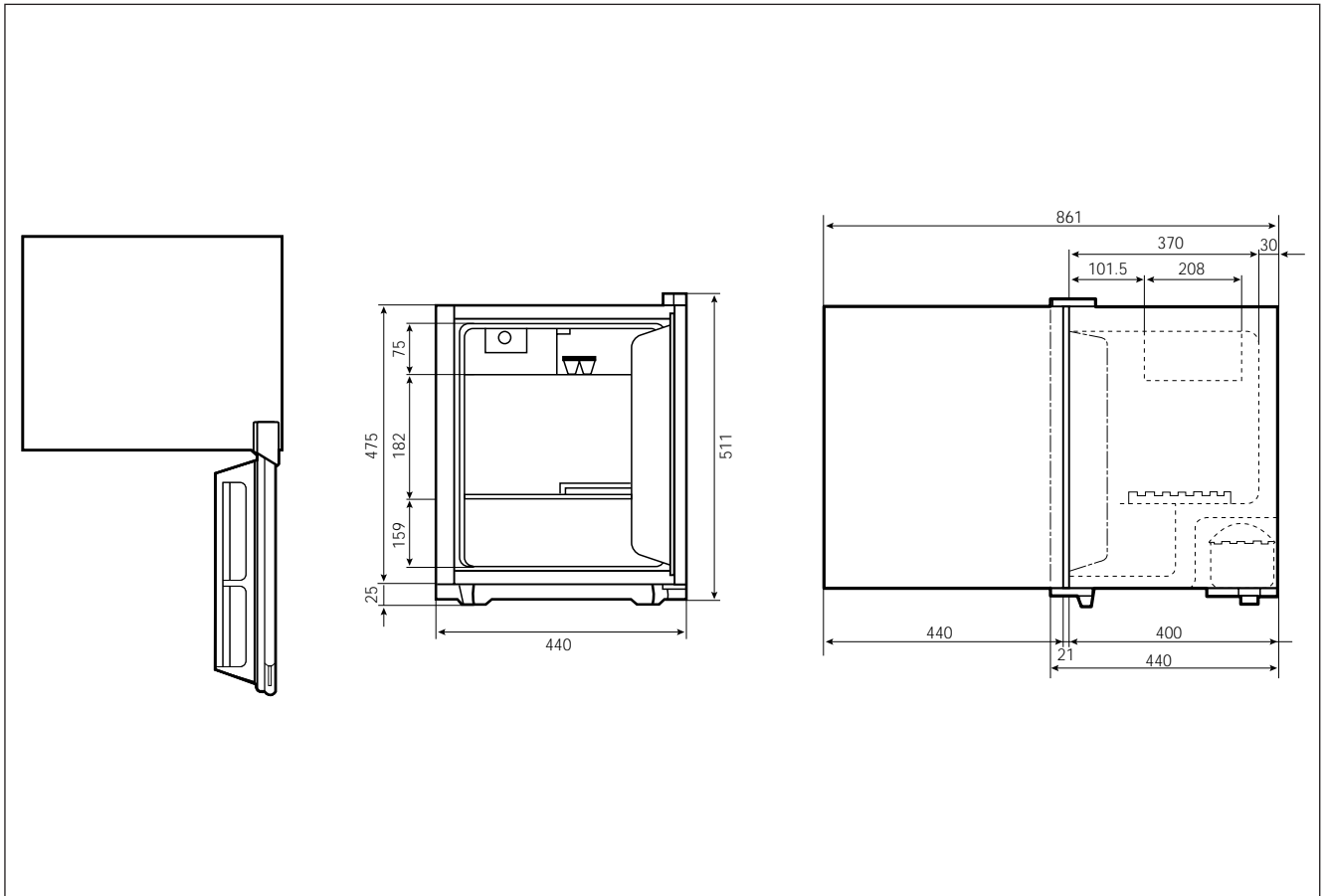

# WIRE DIAGRAM

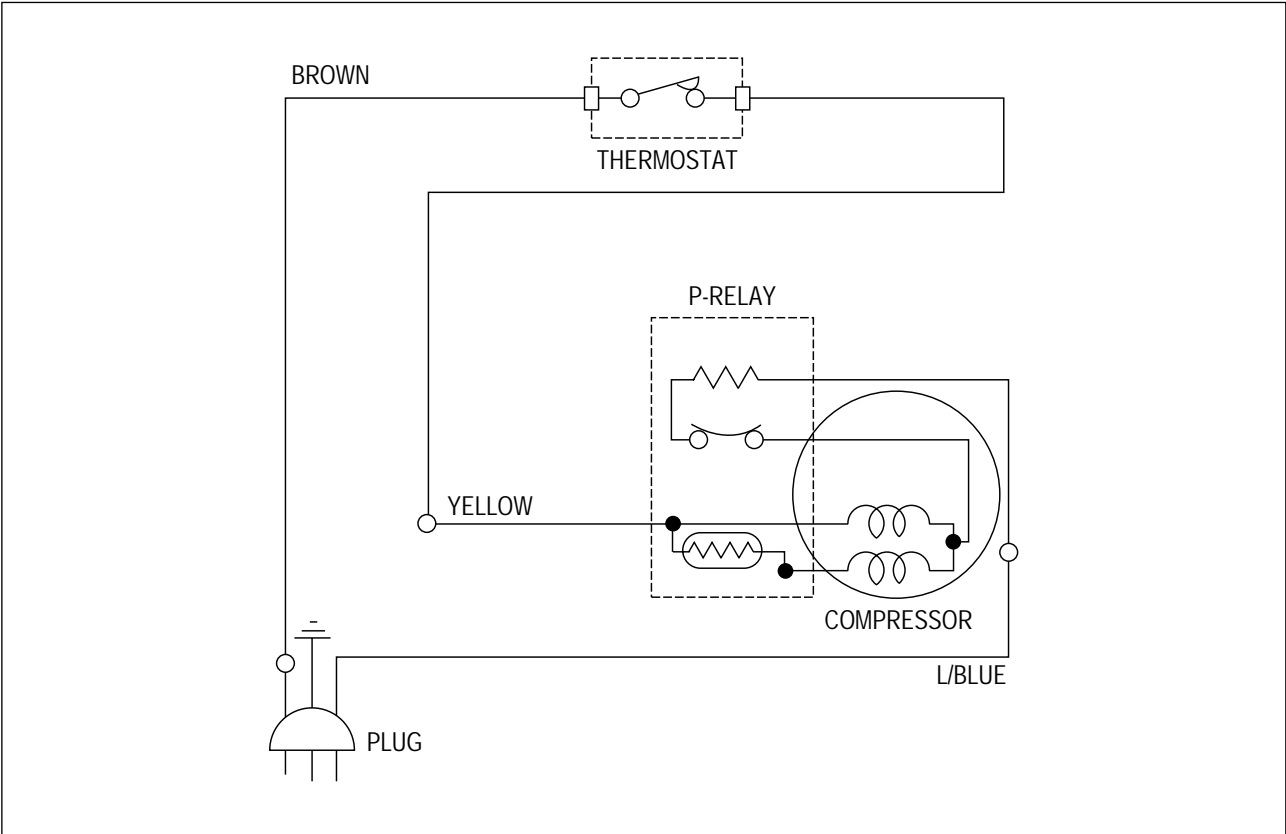

# NAME OF PARTS

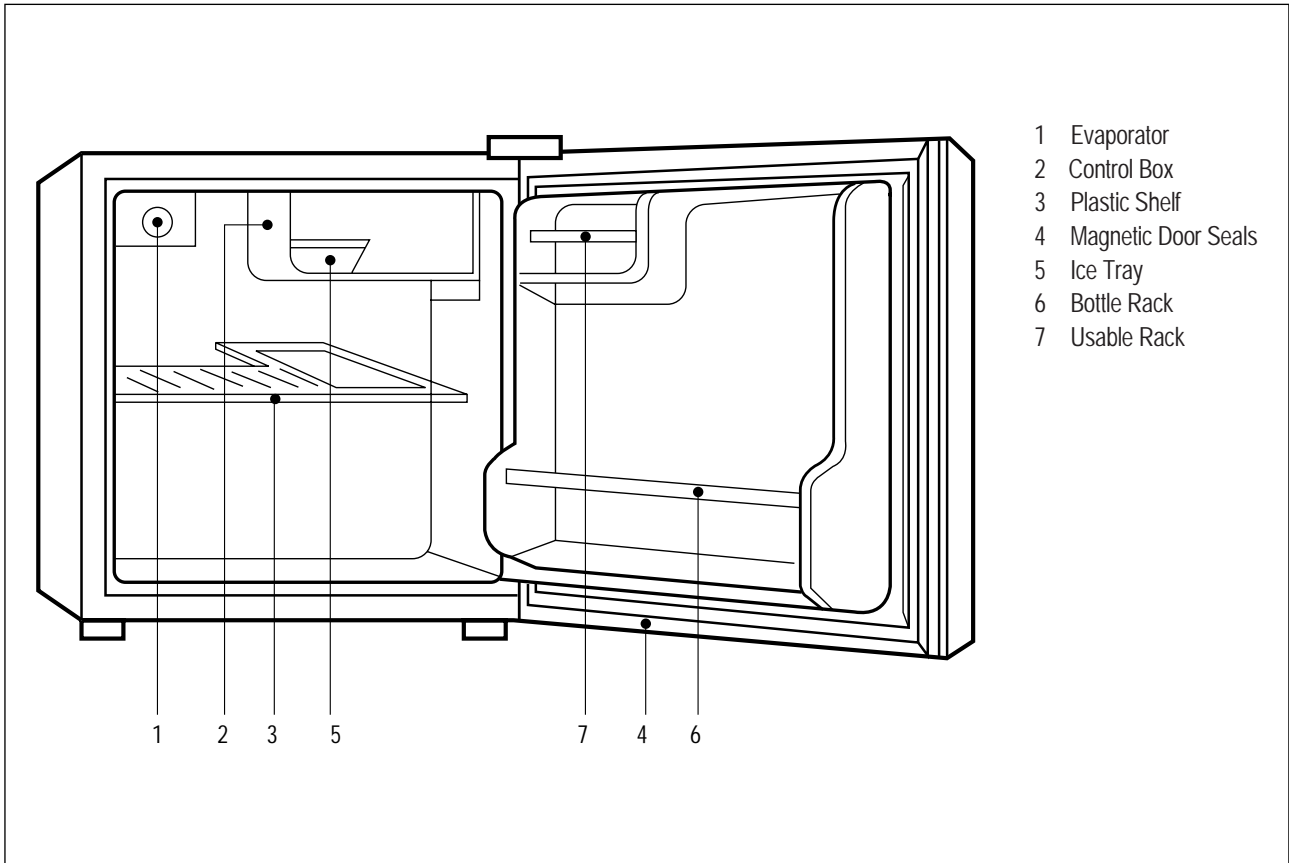

# REFRIGERANT CYCLE DIAGRAM

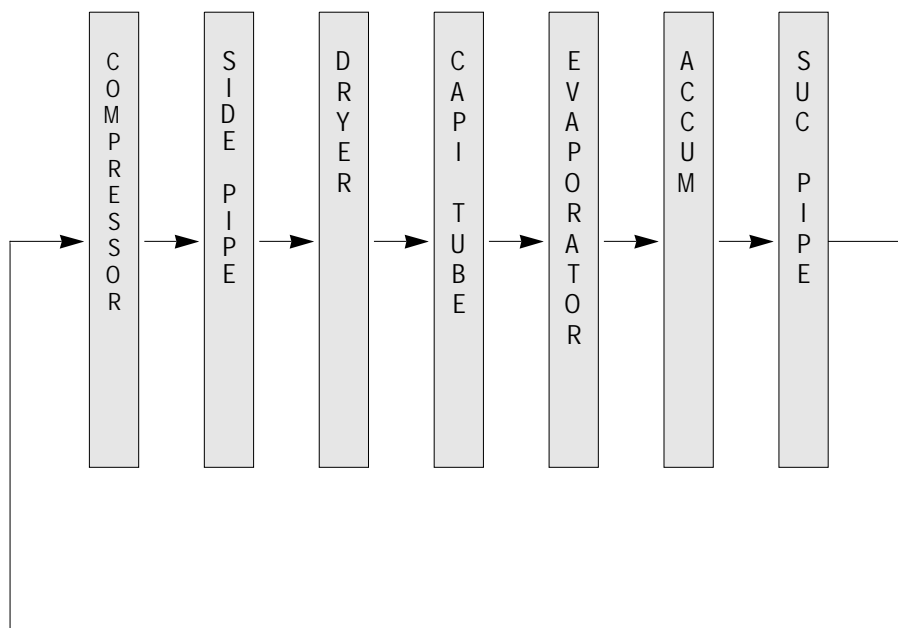
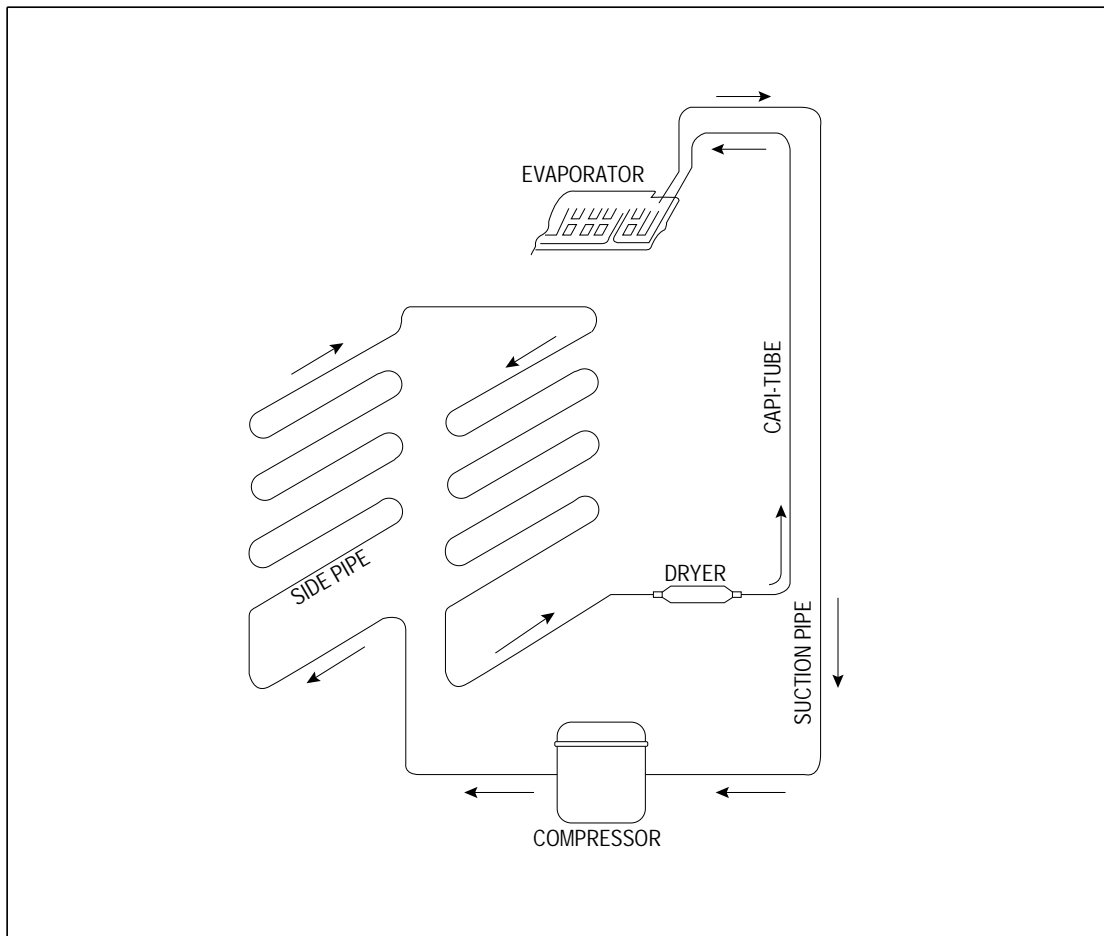

# MACHINE ROOM VIEW AND PART LIST

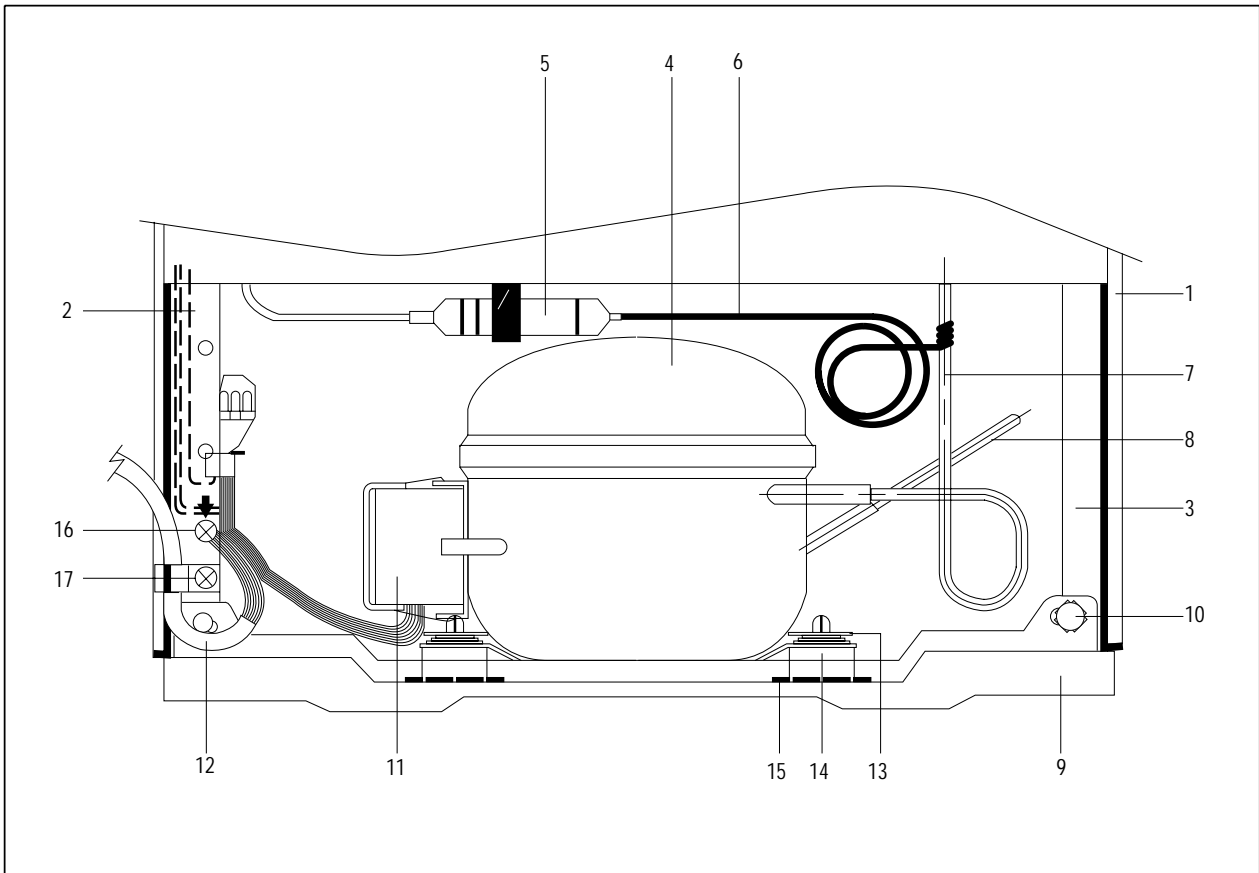

NO	PART NAME	NO	PART NAME	NO	PART NAME
1	CABINET	7	SUCTION PIPE	13	WASHER *T
2	REINFORCE *L	8	PIPE CON	14	ABSORBER
3	REINFORCE *R	9	BASE COMP	15	WASHER *U
4	COMPRESSOR	10	BOLT HEX	16	MACHINE SCREW
5	DRYER	11	P RELAY AS	17	TAPPING SCREW
6	CAPI TUBE	12	POWER CORD		



# MAIN COMPONENTS

## 1.COMPRESSOR

Refrigerant	R12							
Voltage	100V/50,60 Ɛ	110V/60Hz	115,120V/60Hz	127V/60Hz	220V/50Hz	220V/60Hz	230V/50Hz	240V/50Hz
Comp model	DS22LCF1	DS22LCF1	DS22LCF1	DS22LCF1	DS22LCS8	DS22LCS8	DS22LCS8	DS22LCS8
Part Code	3951122X10	3951122X10	3951122X10	3951122X10	3954122X80	3954122X80	3954122X80	3954122X80
Start type	RSIR	RSIR	RSIR	RSIR	RSIR	RSIR	RSIR	RSIR

Refrigerant	R134a							
Voltage	100V/50,60Hz	110V/60Hz	115,120V/60Hz	127V/60 Hz	220V/50Hz	220V/60Hz	230V/50Hz	240V/50Hz
Comp model	DS25LHF0	DS25LHF1	DS25LHF1	DS25LHF2	DS22LCS8	DS22LCS8	DS22LCS8	DS22LCS8
Part Code	3951125Y00	3951125Y10	3951125Y10		3954107F50	3954107F50	3954107F50	3954107F50
Start type	RSIR	RSIR	RSIR	RSIR	RSIR	RSIR	RSIR	RSIR

## 2. RELAY ASSEMBLY

Refrigerant	R12							
Voltage	100V/50,60Hz	110V/60Hz	115,120V/60Hz	127V/60Hz	220V/50Hz	220V/60Hz	230V/50Hz	240V/50Hz
Relay model	197SHB,S068	197SHB,S068	197SHB,S068	197SHB,S068	129RFB,S220	129RFB,S220	129RFB,S220	129RFB,S220
Part Code	3018101411	3018101411	3018101411	3018101411	3018123030	3018123030	3018123030	3018123030

Refrigerant	R134a							
Voltage	100V/50,60Hz	110V/60 Hz	115,120V/60Hz	127V/60 Hz	220V/50Hz	220V/60Hz	230V/50Hz	240V/50Hz
Relay model	734RFB,S068	174SHB,S068	174SHB,S068	213THB,S068	129SHB,S220	129SHB,S220	129SHB,S220	129SHB,S220
Part Code	3018122250	3018108140	3018102122	3018123121	3018123080	3018123080	3018122201	3018122201

## 3.CONTROL SWITCH

Refrigerant	R12							
Voltage	100V/50,60Hz	110V/60Hz	115,120V/60Hz	127V/60Hz	220V/50Hz	220V/60Hz	230V/50Hz	240V/50 Hz
Relay model	PFN-110U-02A	PFN-110U-02A	PFN-110U-02A	PFN-110U-02A	PFN-110U-02A	PFN-110U-02A	PFN-110U-02A	PFN-110U-02A
Part Code	4004V70142	4004V70142	4004V70142	4004V70142	4004V70142	4004V70142	4004V70142	4004V70142

Refrigerant	R134a							
Vol tage	100V/50,60 Hz	110V/60 Hz	115,120V/60Hz	127V/60 Hz	220V/50Hz	220V/60 Hz	230V/50Hz	240V/50Hz
Relay model	PFN-110U-02S	PFN-110U-02D	PFN-110U-02D	PFN-110U-02D	PFN-110U-02D	PFN-110U-02D	PFN-110U-02D	PFN-110U-02D
Part Code	3018303120	3018303100	3018303100	3018303100	3018303100	3018303100	3018303100	3018303100

## 4. DRYER

Refrigerant	R12	R134a
Spec.	10g	10g
Part code	3016801301	3016801301

POWER CORD SPECIFICATION

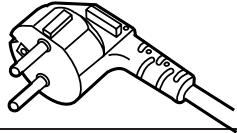
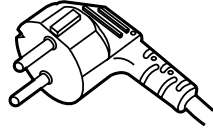
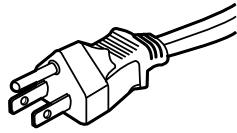
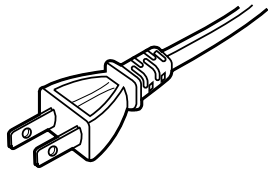
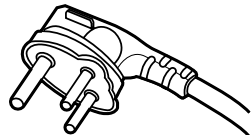
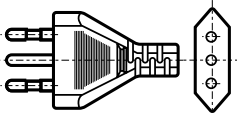
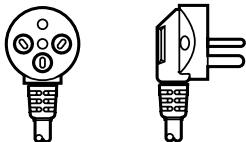
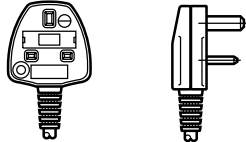
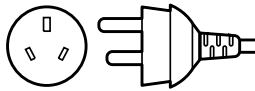
NO	SHAPE OF POWER CODE	PART CODE	DESCRIPTION	REMARK
1		3011300321	CP-2PIN	
2		4017J17101	CP-2PIN	
3		4006D17101	KP-30	
		3011304520	DKP-301U	
4		401PD17101	KP-211	
5		3011316201	BP-3PIN	
6		3011300971	#267	FOR SWISS
		3011303020		FOR OTHER CONURTY
7		3011316101		FOR ISRAEL
8		3011303901	BS-1363A	FOR EUROPEAN&SAUDI
		3011303921		FOR SINGAPORE
		3011303040		FOR OTHER COUNTRY
9		3011301171		

# DOOR COLOR SPECIFICATION

## 1. ASSEMBLY URETHAN DOOR

Refrigerant		R12, R134a							
TPYE		Key type				Non Key type			
Color Type		Dull lamina sheet	High flossy Lamina sheet	Normal PCM	High glossy bright PCM	Dull lamina sheet	High flossy Lamina sheet	Normal PCM	High glossy bright PCM
Part Code	Normal	-	PFRT2KB061	PFRT1KB061	-	-	PFRT2NB061	PFRT1NB061	-
	Deco	-	PFRT2KB063	PFRT1KB063	-	-	PFRT2NB063	PFRT1NB063	-
	Special	-	PFRT2NB065	PFRT1NB065	-	-	PFRT2NB065	PFRT1KB065	-

1. PCM type

NO	COLOR CHIP	COLOR NAME
1		P/WITH (WH069)
2		'94 L/GRAY (GY158)
3		'95 L/GRAY (GY259)
4		'94 M/GRAY (GY331)
5		'95 M/GRAY (GY335)
6		'97 M/GRAY (GY267)
7		M. D/GRAY (GY750)
8		N/BLUE (BL718)
9		MINT GREEN (GN206)
10		'97 BEIGE (BE215)

## DOOR COLOR SPECIFICATION

### 2. Lamina sheet type

NO	COLOR CHIP	COLOR NAME
1		P/WITH (WH069)
2		'94 L/GRAY (GY158)
3		'95 L/GRAY (GY259)
4		'94 M/GRAY (GY331)
5		'95 M/GRAY (GY335)
6		'97 M/GRAY (GY267)
7		M. D/GRAY (GY750)
8		N/BUE (BL718)
9		MINT GREEN (GN206)
10		S/GOLD
11		G/GREEN

# EXPLODED VIEW AND PARTS LIST

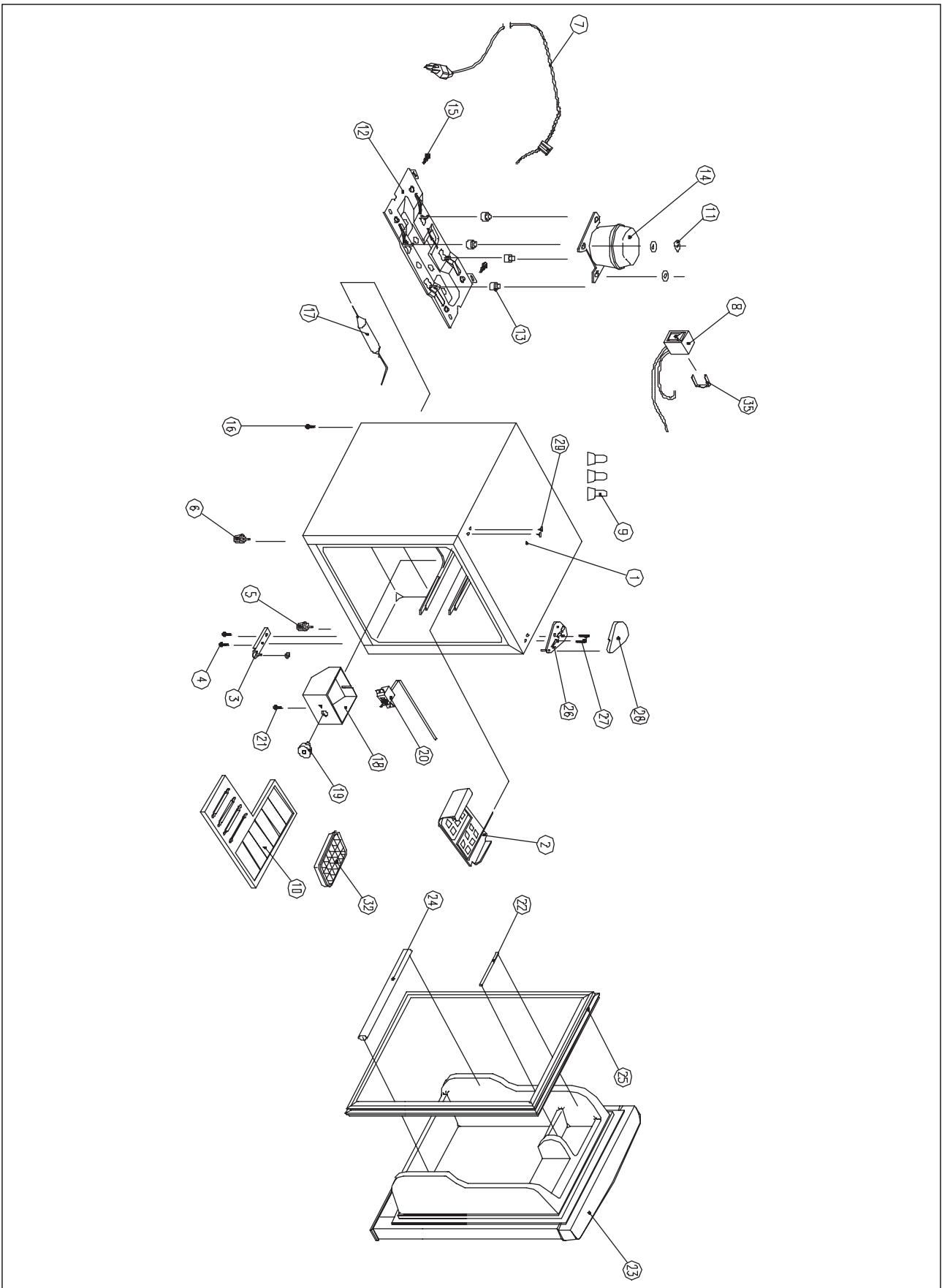

## EXPLODED VIEW AND PARTS LIST

✓ CAUTION : In this Service Manual, some parts can be changed for improving their performance without notice in the parts list. So, if you need the latest parts information, please refer to PPL(Parts Price List)in Service information Center(<http://svc.dwe.co.kr>)

NO	PART CODE	PART NAME	DESCRIPTION	QUANTITY	REMARK
1	PFCP00A300	ASSY CAB PRE	FRM-06	1	
2	3017000320	EVAPORATOR AS	FRM-06	1	
3	3012902500	HINGE *U	SPHC-H T2.3	1	
4	7147501011	SCREW TAPPING	T2 5X10 MFZN	2	
5	3012103300	FOOT ADJ AS	PP INSERT	1	
6	4006D32533	FOOT *F	PP(JI-360)	1	
7		CORD POWER AS		1	Refer to #7
8		SWITCH P RELAY AS		1	Refer to #7
9	4005G17020	CEC	PA-6 ID2.3	3	
10	3017804601	SHELF	HIPS	1	
11	3016004120	SPECIAL WASR	SPG T0.8	3	
12	3010309850	BASE COMP	SBHG T0.8	1	
13	3010102910	ABSORBER COMP	NBR	4	
14		COMPRESSOR		1	Refer to # 7
15	7147501011	SCREW TAPPING	T2 5X10 MFZN	2	
16	7122501211	SCREW TAPPING	T2S TRS 5X12 MFZN	2	
17		DRYER AS	NON CFC 10g	1	Refer to #7
18	4017J70115	BOX CONTROL	HIPS	1	RAMP TYPE
	3010502903				
19	4006D70027	KNOB	HIPS	1	
20		THERMOSTAT		1	Refer to #7
21	7112402011	SCREW TAPPING	T1 TRS 4X20 MFZN	1	
22	3019024600	POCKER BAR	HIPS	1	
23		ASSY R DOOR TOTAL		1	Refer to #8
24	3019024700	POCKET BAR	PVC-H	3	
25	3012316600	GASKET DR AS	PVC	1	
26	3012910600	HINGE *T S	FRM-123	1	
27	7051501611	SCREW MACHINE	PAN 5X16 SW MFZN	2	
28	3011409400	COVER *T HINGE	PP	1	
29	3010927900	CAP CAB HOLE	PP	2	Option
30	7112401211	SCREW TAPPING	T1 TRS 4X12 MFZN	1	
31					
32					
33					
34					
35	3816100110	RELAY BAND	SUS304 T0.7	1	