

Service Manual

Refrigerator

**MODEL : FN-063R
FN-065R
FN-093R
FN-146R**

✓ **Caution :**

In this Manual, some parts can be changed for improving, their performance without notice in the parts list. So, if you need the latest parts information, please refer to PPL(Parts Price List) in Service Information Center (<http://svc.dwe.co.kr>).

CONTENTS

1. SPECIFICATION	2
2. EXTERNAL VIEW	3
3. WIRE DIAGRAM	5
4. NAME OF PARTS	6
5. REFRIGERANT CYCLE DIAGRAM	8
6. MACHINE ROOM VIEW AND PARTS LIST	9
7. MAIN COMPONENTS	10
8. EXPLODED VIEW AND PARTSLIST	13

SPECIFICATION

MODEL NAME		FN-063/065R	FN-093R	FN-146R
Refrigerant	R600a	21g	28g	32g
Cooling System		Aluminum- embossed Plat "Roll Bond" type		
Refrigeration System		Natural Cold- air Convention		
Defrost System		Natural		
Defrost Operation		Manual start & Stop		
Cold Control		Adjustable Dial		
Capacity	Freezer	-		
	Refrigerator	-		
	Total	45ℓ	75ℓ	122ℓ
External Dimension	Height	511 mm	726mm	858 mm
	Width	440 mm	440mm	480 mm
	depth	452 mm	452mm	531 mm
Net Weight		16Kg	19Kg	25Kg

EXTERNAL VIEW

FN-063/065R

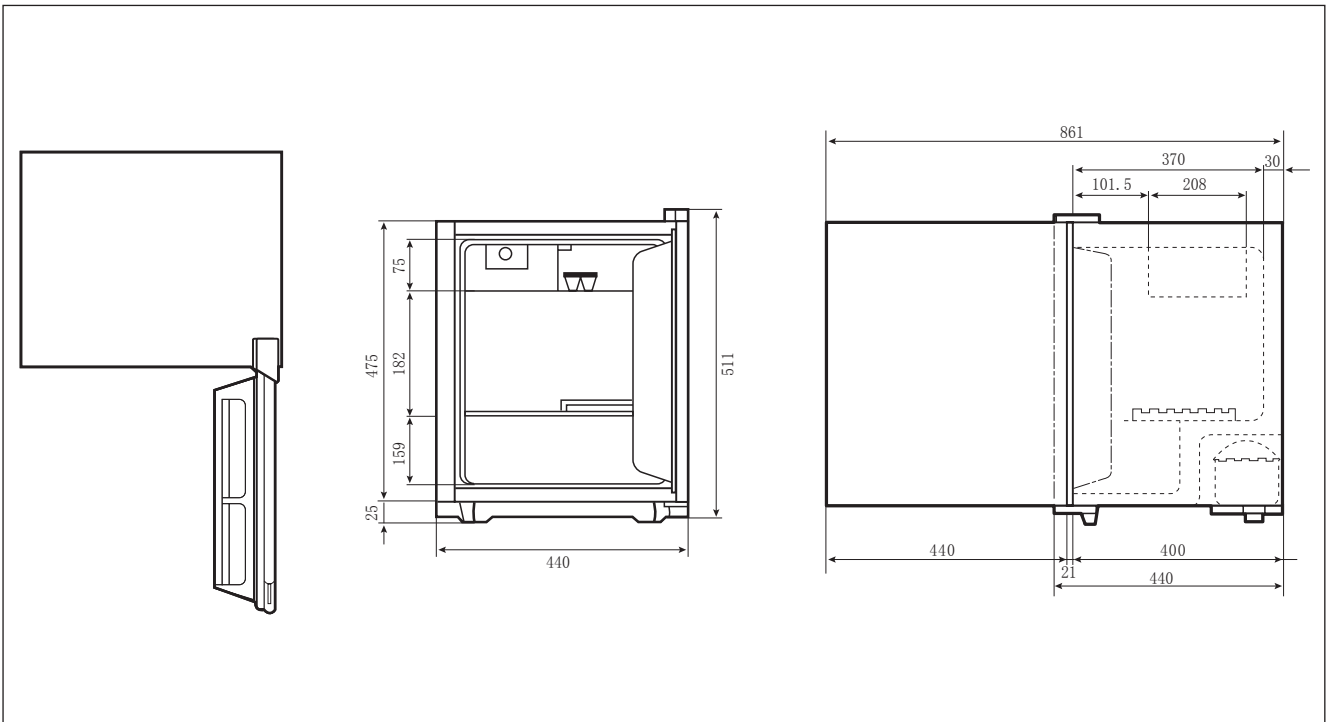

FN-093R

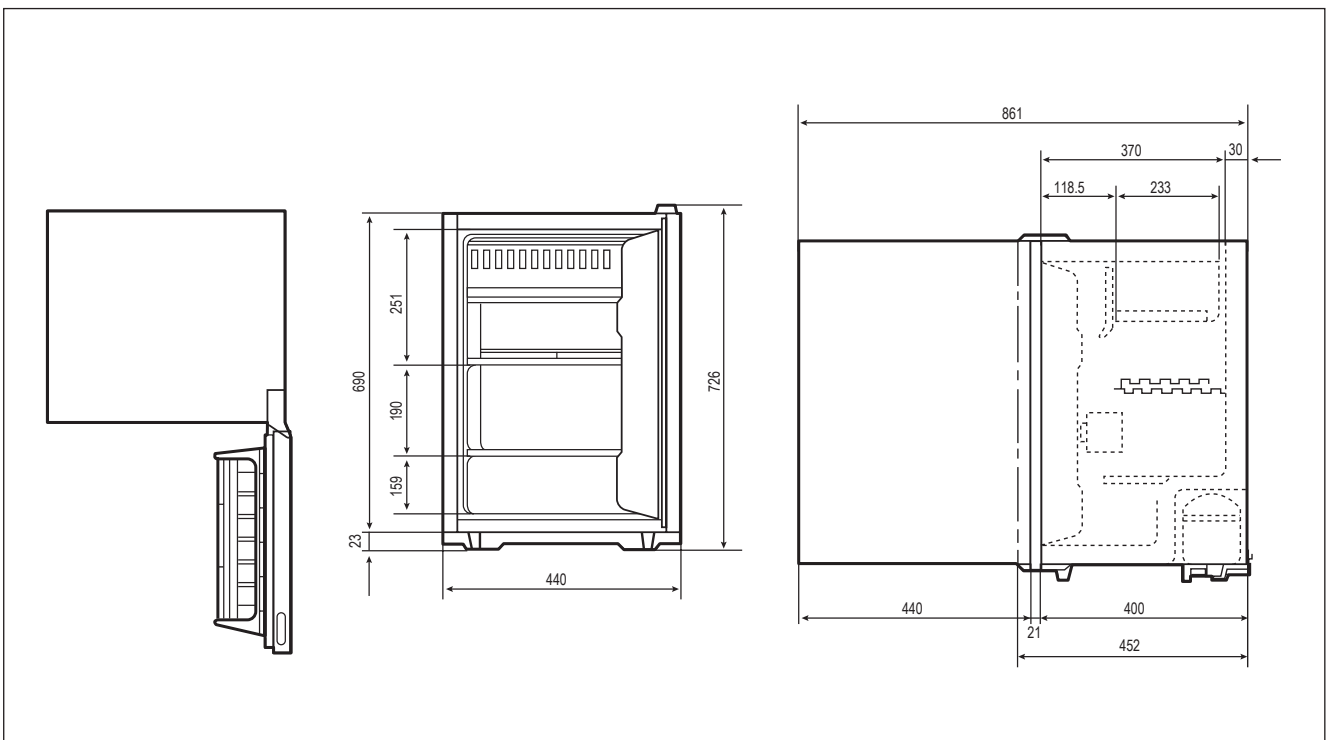

EXTERNAL VIEW

FN-146R

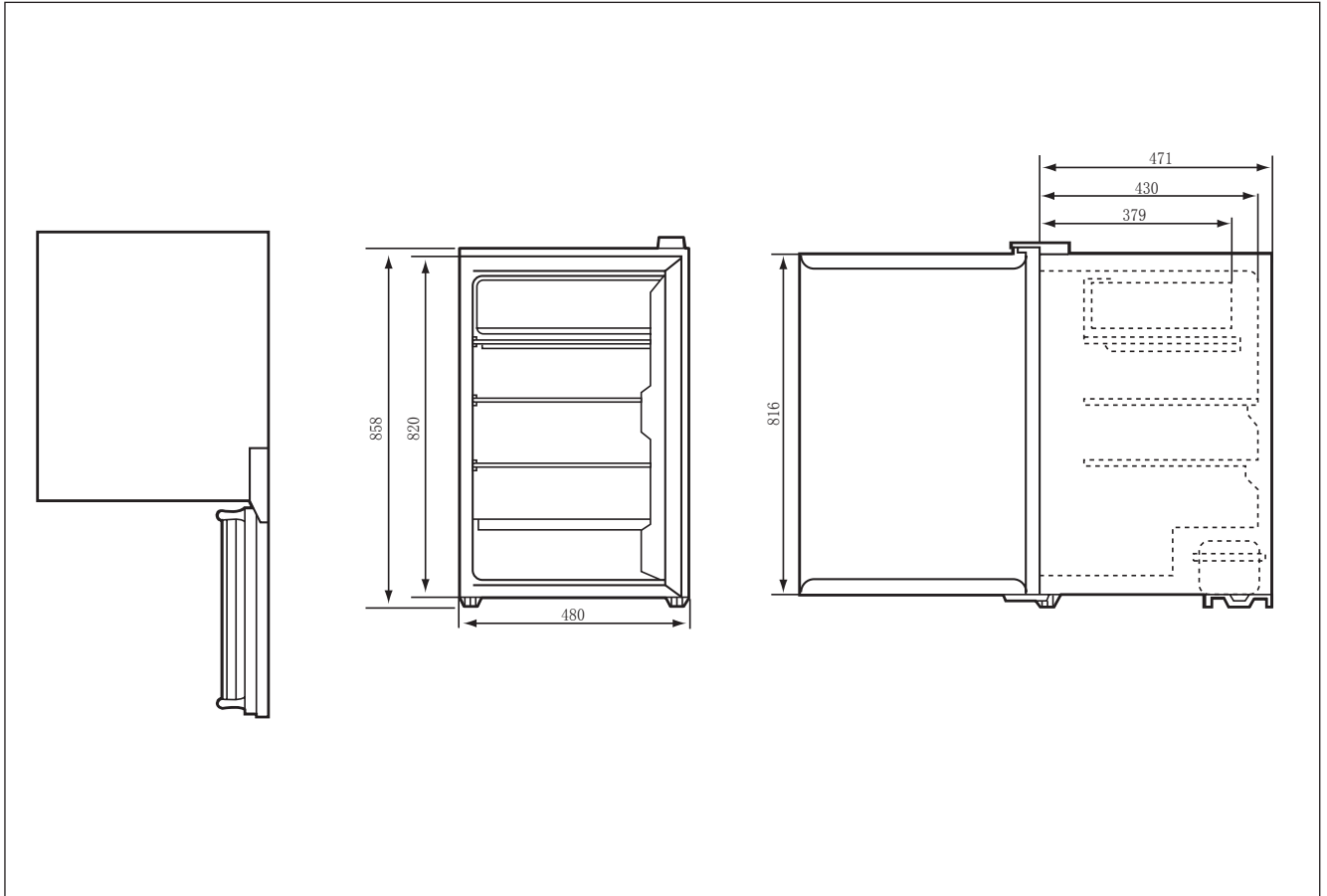

WIRE DIAGRAM

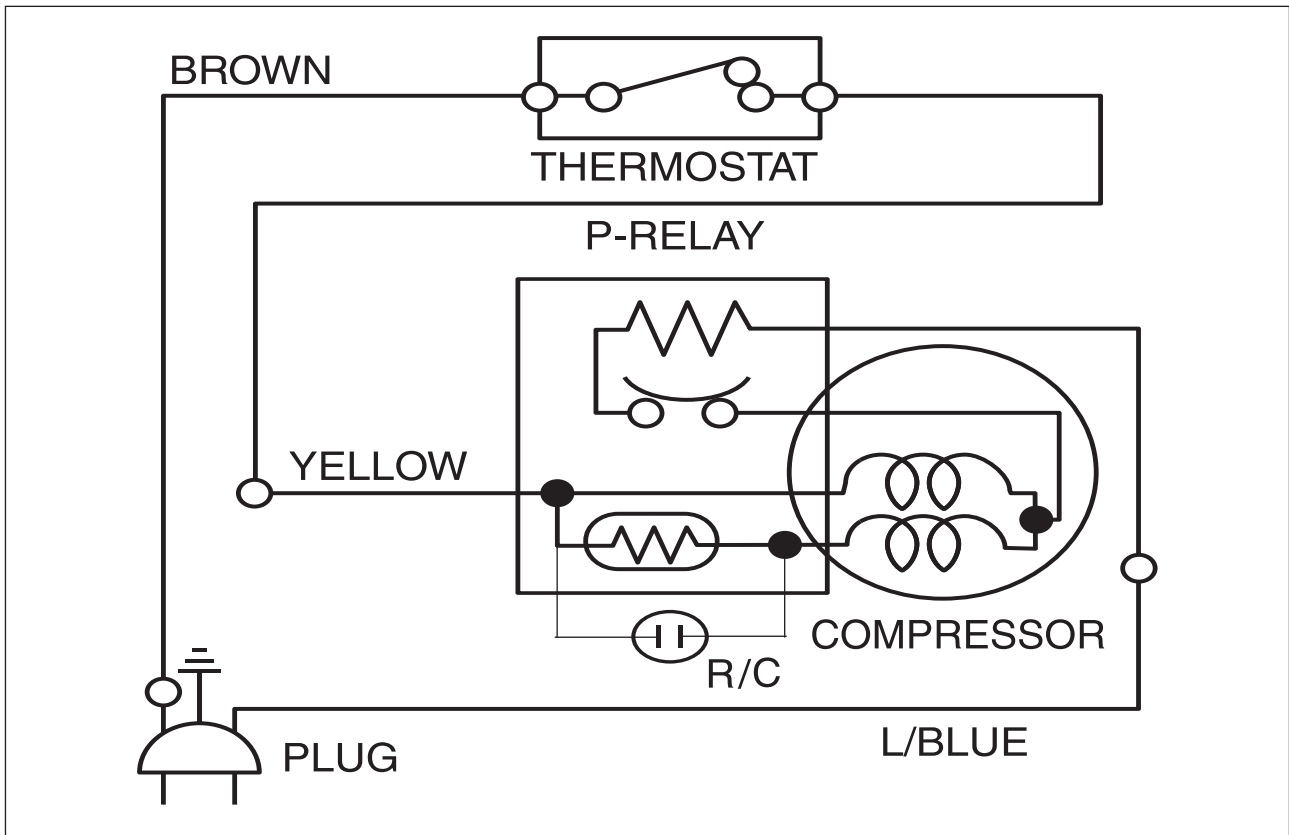

NAME OF PARTS

FN-063/065R

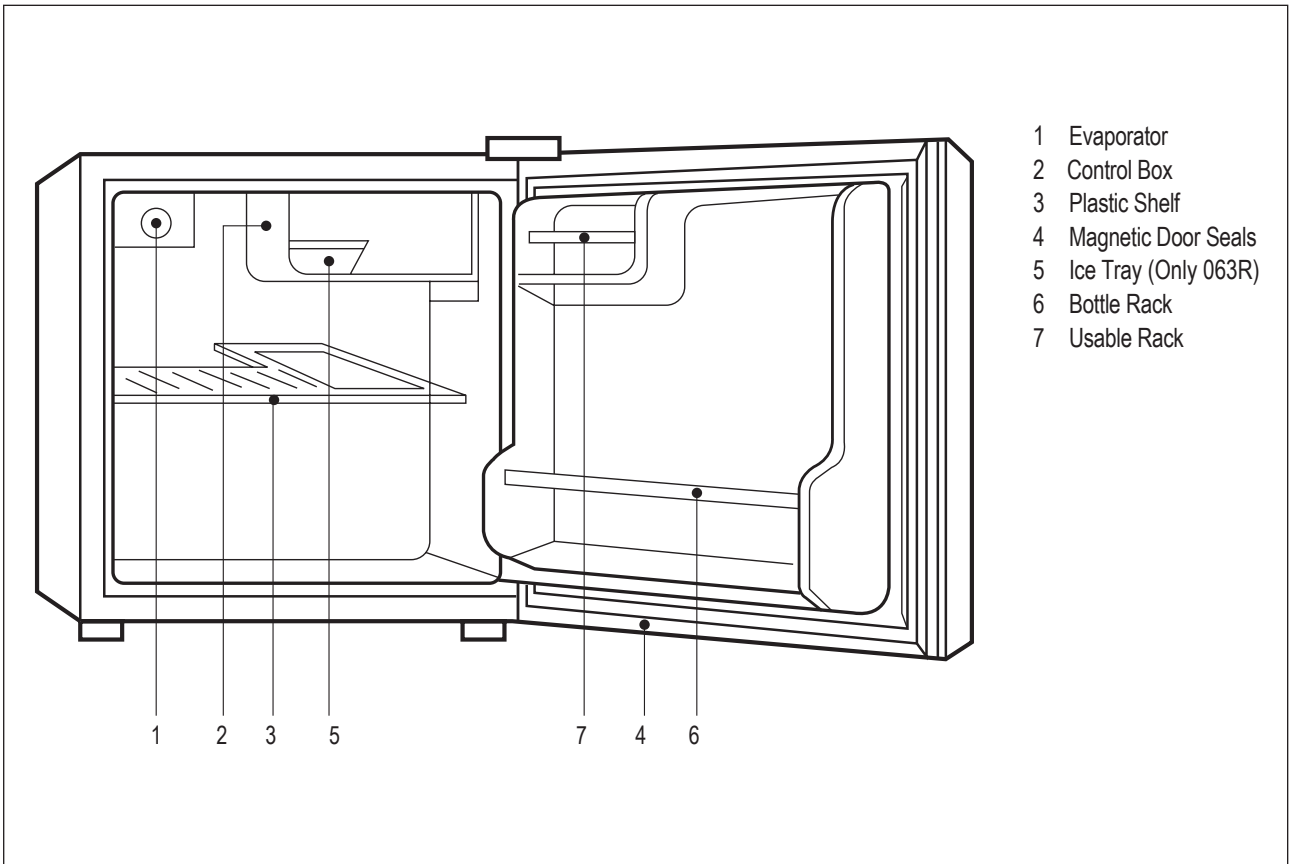

FN-093R

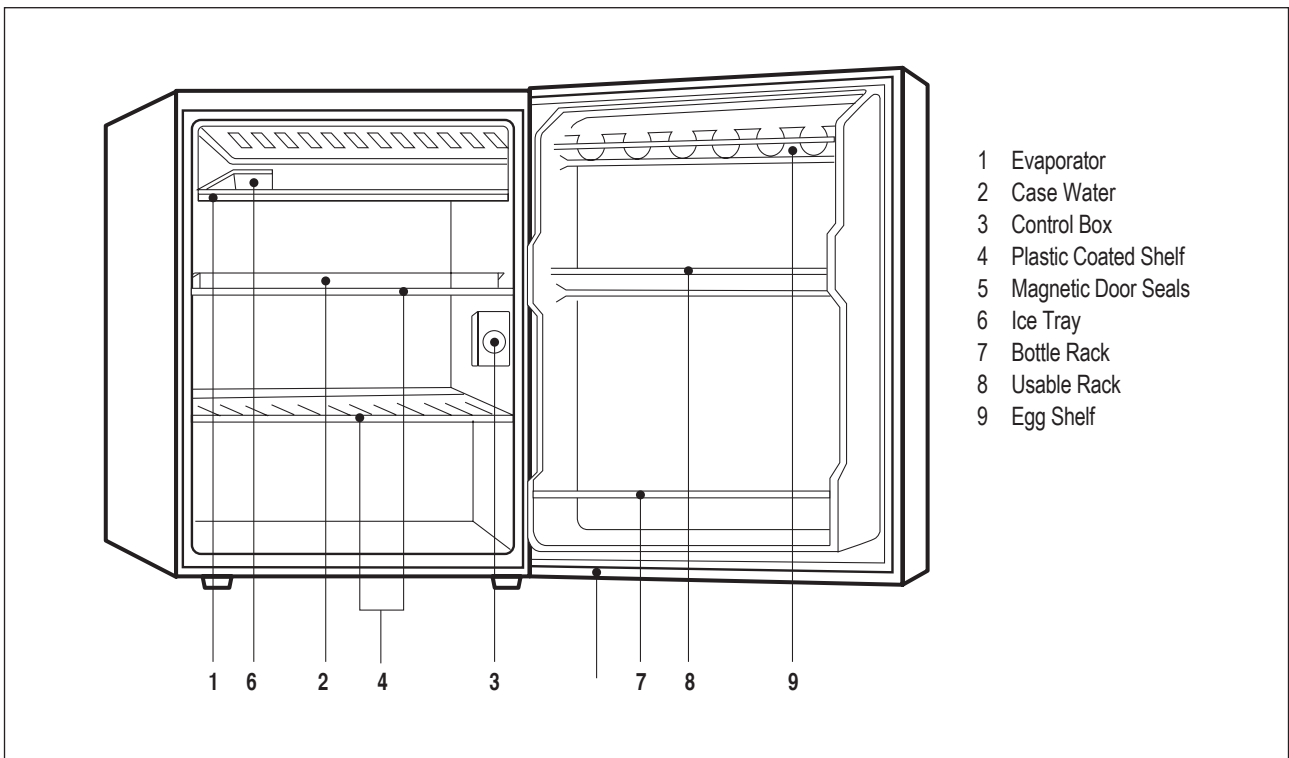

NAME OF PARTS

FN-146R

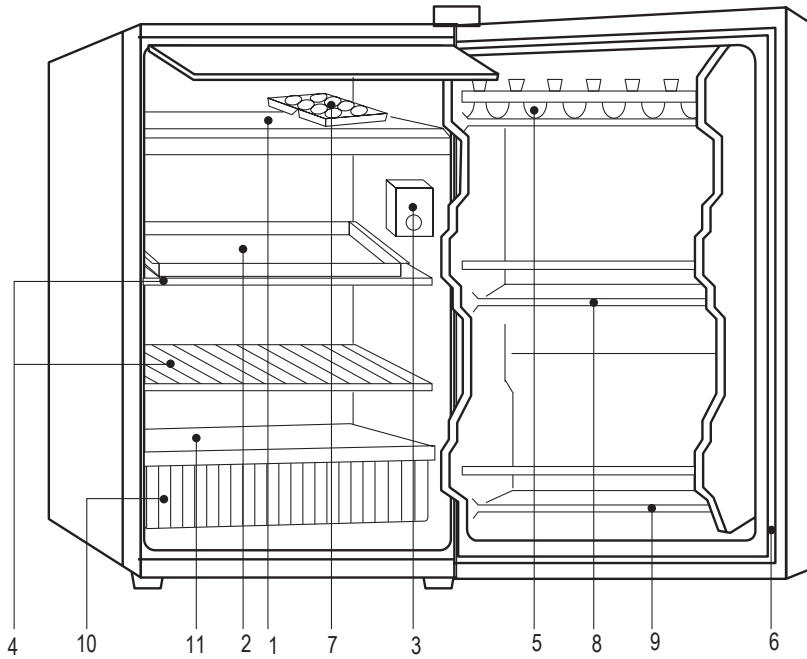

- 1 Evaporator
- 2 Case Water
- 3 Control Box
- 4 Plastic Coated Shelf
- 5 Rack
- 6 Magnetic Door Seals
- 7 Ice Tray
- 8 Usable Rack
- 9 Bottle Rack
- 10 Crisper
- 11 Slide Out Crisper Cover

REFRIGERANT CYCLE DIAGRAM

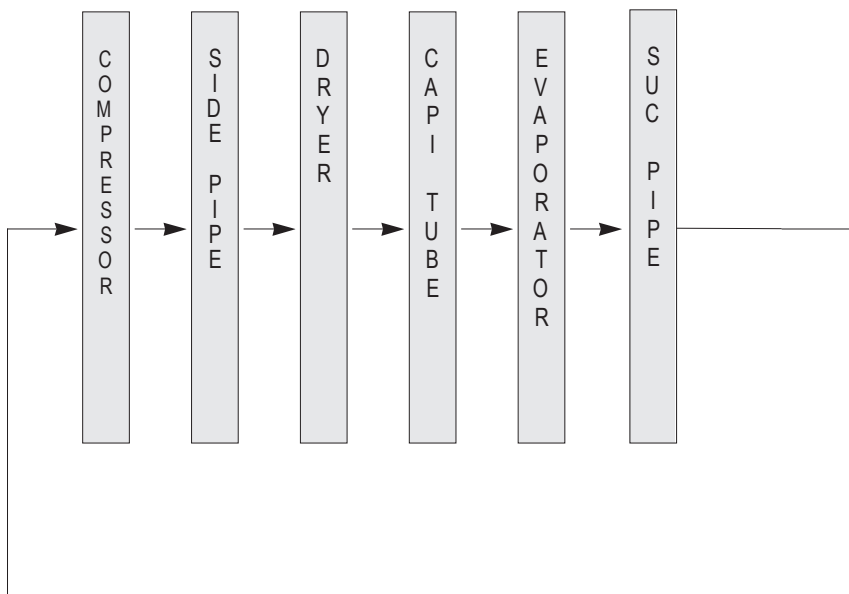
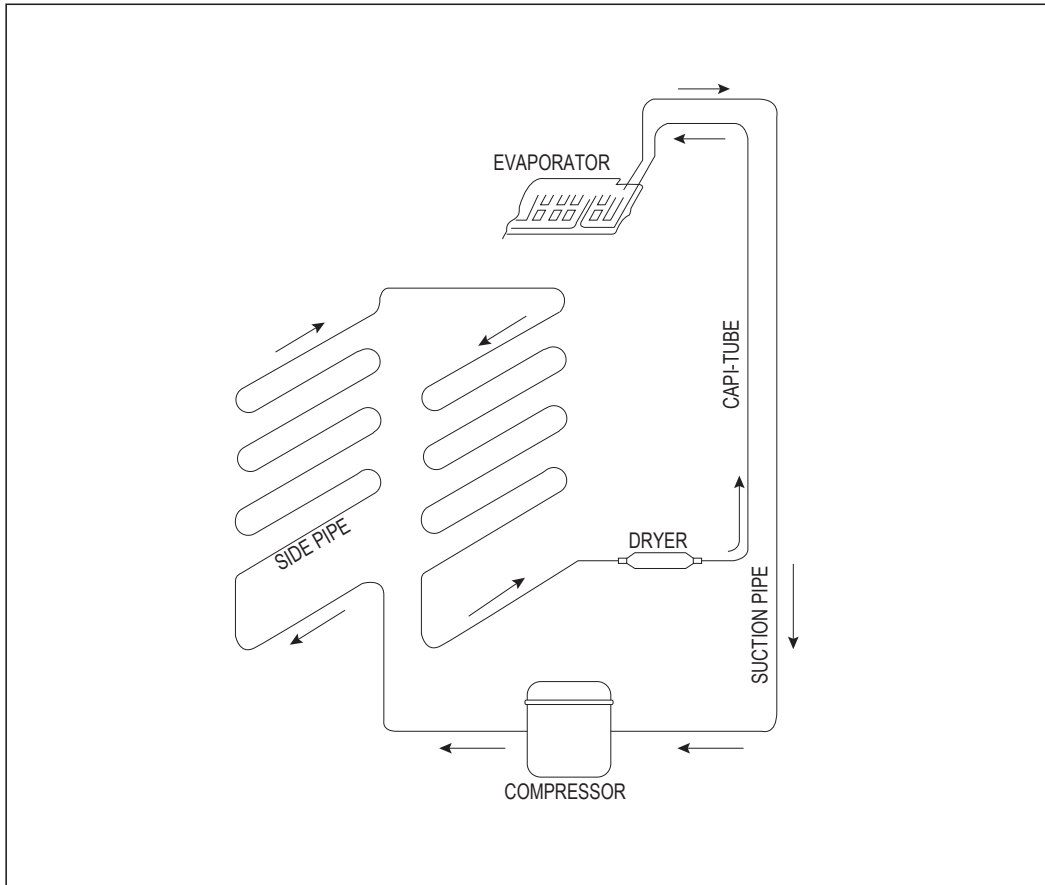

MACHINE ROOM VIEW AND PART LIST

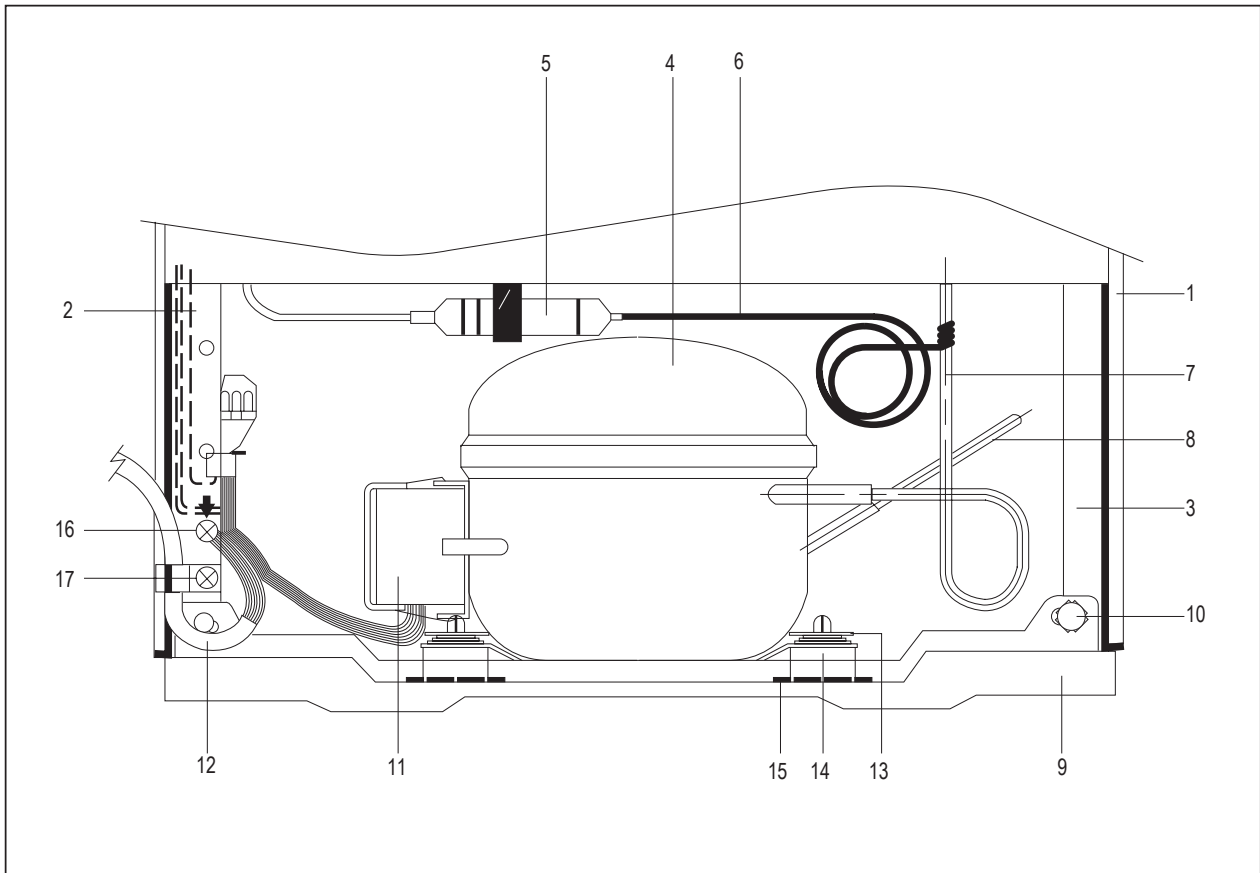

NO	PART NAME	NO	PART NAME	NO	PART NAME
1	CABINET	7	SUCTION PIPE	13	WASHER *T
2	REINFORCE *L	8	PIPE CON	14	ABSORBER
3	REINFORCE *R	9	BASE COMP	15	WASHER *U
4	COMPRESSOR	10	BOLT HEX	16	MACHINE SCREW
5	DRYER	11	P RELAY AS	17	TAPPING SCREW
6	CAPI TUBE	12	POWER CORD		

MAIN COMPONENTS

1. COMPRESSOR

Refrigerant	R600a							
Voltage	220V-240V/50Hz							
Comp model	SK53CY							
Part Code	3953140730							
Start type	RSCR							

2. RELAY ASSEMBLY

Refrigerant	R600a							
Voltage	220V-240V/50Hz							
Relay model	QP-15C/B40-105							
Part Code	3018123280							

3. CONTROL SWITCH

Refrigerant	R600a							
Voltage	220V-240V/50Hz	220V-240V/50Hz						
Relay model	WPFE18A-02D	WPFE18A-02SS						
Part Code	3018300730	3018300880						

4. DRYER

Refrigerant	R600a
Spec.	8g
Part code	3016801302

POWER CORD SPECIFICATION

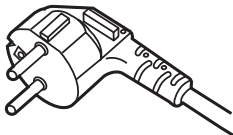
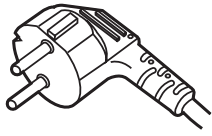
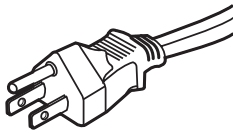
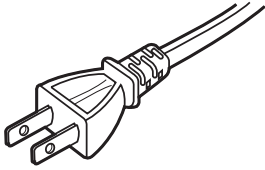
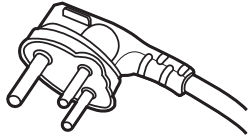
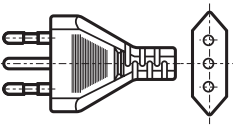
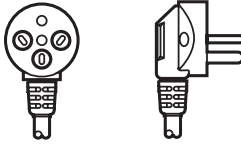
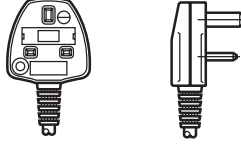
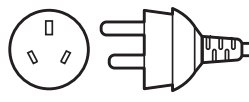
NO	SHAPE OF POWER CODE	PART CODE	DESCRIPTION	REMARK
1		3011300321	CP-2PIN	
2		4017J17101	CP-2PIN	
3		4006D17101	KP-30	
		3011304520	DKP-301U	
4		401PD17101	KP-211	
5		3011316201	BP-3PIN	
6		3011300971	#267	FOR SWISS
		3011303020		FOR OTHER CONURTY
7		3011316101		FOR ISRAEL
8		3011303901	BS-1363A	FOR EUROPEAN&SAUDI
		3011303921		FOR SINGAPORE
		3011303040		FOR OTHER COUNTRY
9		3011301171		

DOOR COLOR SPECIFICATION

1. ASSEMBLY URETHAN DOOR

Refrigerant		R600a			
TPYE		Non Key Type			
Color Type		Dull lamina sheet	High flossy Lamina sheet	Normal PCM	High glossy bright PCM
Part Code	Normal	-	PFRT2KB071	PFRT1KB071	
	Deco	-	PFRT2KB073	PFRT1KB073	
	Special	-	PFRT2NB075	PFRT1NB075	

EXPLODED VIEW AND PARTS LIST

1.FN-063/065R

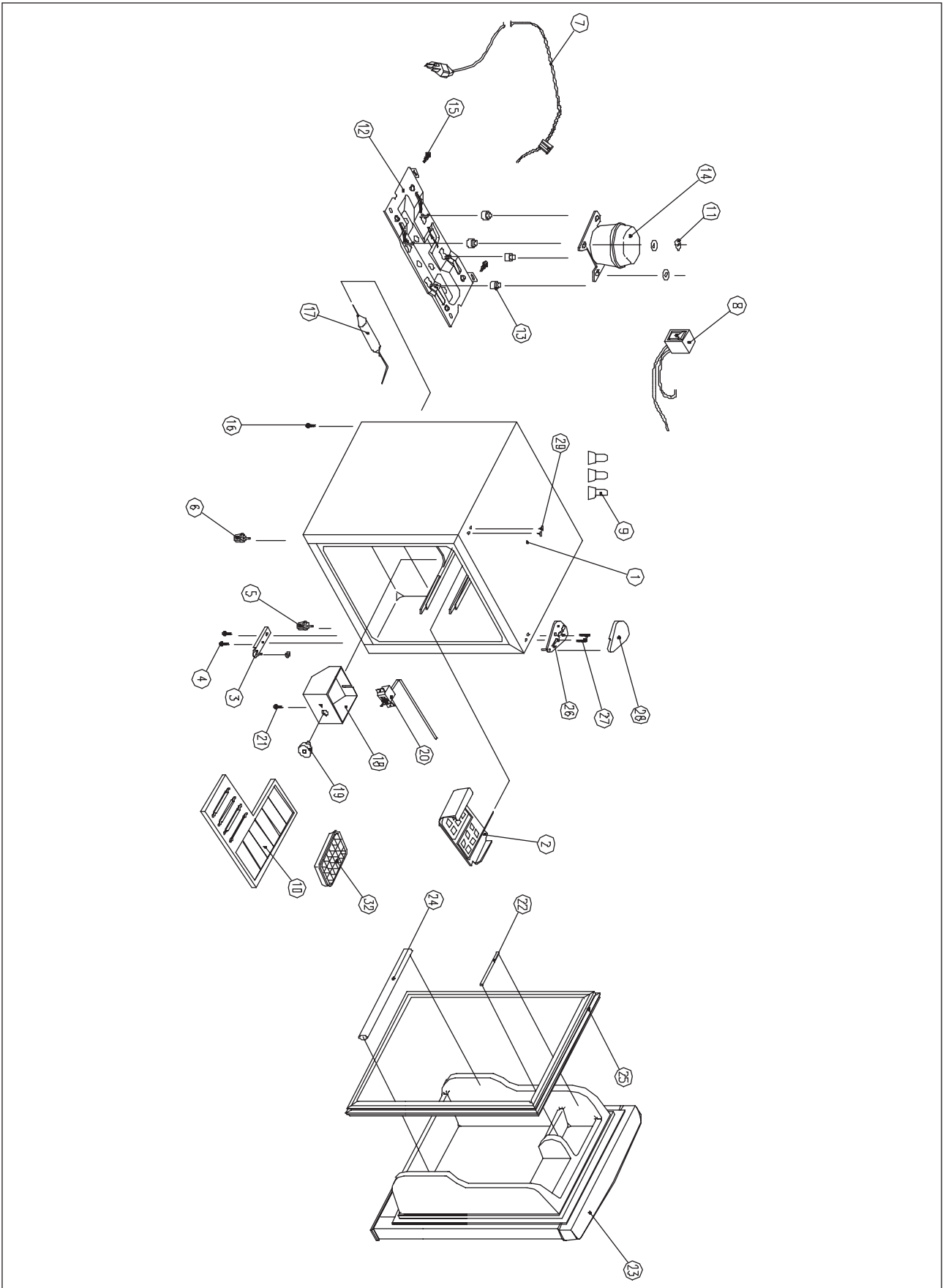

EXPLODED VIEW AND PARTS LIST

✓ **CAUTION** : In this Service Manual, some parts can be changed for improving their performance without notice in the parts list. So, if you need the latest parts information, please refer to PPL(Parts Price List)in Service information Center(<http://svc.dwe.co.kr>)

NO	PART CODE	PART NAME	DESCRIPTION	QUANTITY	REMARK
1	PFCP00A440	ASSY CAB PRE	FRM-06	1	
2	3017000240	EVAPORATOR AS	FRM-06	1	
3	3012902501	HINGE *U	SPHC-H T2.3	1	
4	7147501011	SCREW TAPPING	T2 5X10 MFZN	2	
5	3012103301	FOOT ADJ AS	PP INSERT	1	
6	4006D32534	FOOT *F	PP(JI-360)	1	
7		CORD POWER AS		1	Refer to #11
8		SWITCH P RELAY AS		1	Refer to #10
9	4005G17020	CEC	PA-6 ID2.3	3	
10	3017804601	SHELF	HIPS	1	
11	3016004120	SPECIAL WASR	SPG T0.8	3	
12	3010309850	BASE COMP	SBHG T0.8	1	
13	3010102910	ABSORBER COMP	NBR	4	
14		COMPRESSOR		1	Refer to # 10
15	7147501011	SCREW TAPPING	T2 5X10 MFZN	2	
16	7122501211	SCREW TAPPING	T2S TRS 5X12 MFZN	2	
17		DRYER AS	NON CFC 10g	1	Refer to #10
18	3010502904	BOX CONTROL	HIPS	1	
19	4006D70027	KNOB	HIPS	1	
20		THERMOSTAT		1	Refer to #10
21	7112402011	SCREW TAPPING	T1 TRS 4X20 MFZN	1	
22	3019024600	POCKER BAR	HIPS	1	
23		ASSY R DOOR TOTAL		1	Refer to #12
24	3019024700	POCKET BAR	PVC-H	3	
25	3012316600	GASKET DR AS	PVC	1	
26	3012910600	HINGE *T S	FRM-123	1	
27	7051501611	SCREW MACHINE	PAN 5X16 SW MFZN	2	
28	3011409400	COVER *T HINGE	PP	1	
29	3010927900	CAP CAB HOLE	PP	2	Option
30	7112401211	SCREW TAPPING	T1 TRS 4X12 MFZN	1	

EXPLODED VIEW AND PARTS LIST

2.FN-093R

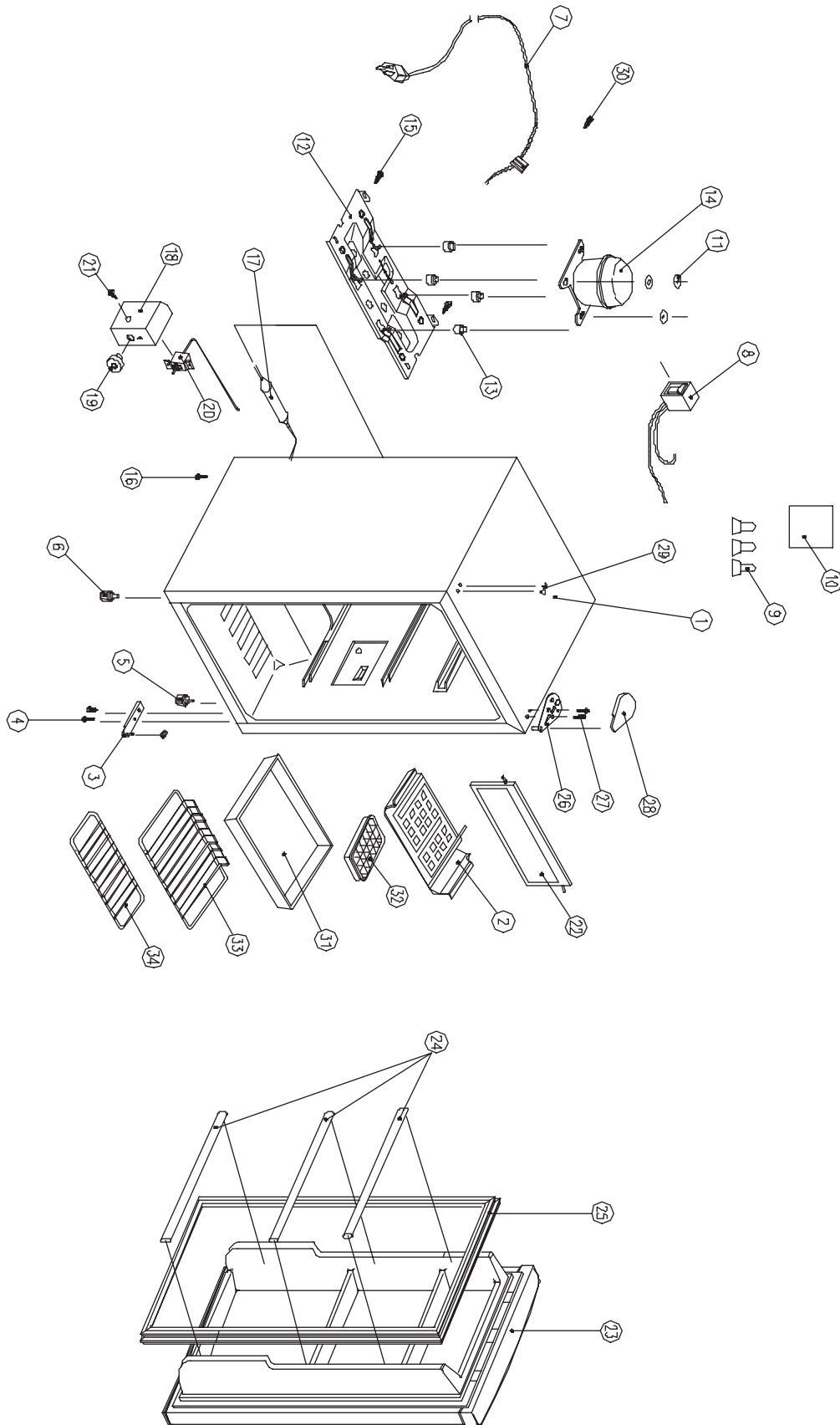

EXPLODED VIEW AND PARTS LIST

✓ CAUTION : In this Service Manual, some parts can be changed for improving their performance without notice in the parts list. So, if you need the latest parts information, please refer to PPL(Parts Price List)in Service information Center(<http://svc.dwe.co.kr>)

NO	PART CODE	PART NAME	DESCRIPTION	QUANTITY	REMARK
1	PFCP00B440	ASSY CAB PRE	FRM-08	1	
2	4016V0310C	EVAPORATOR AS	FRM-08	1	
3	3012902500	HINGE *U	SPHC-H T2.3	1	
4	7147501011	SCREW TAPPING	T2 5X10 MFZN	2	
5	3012103301	FOOT ADJ AS	PP INSERT	1	
6	4006D32534	FOOT *F	PP(JI-360)	1	
7		CORD POWER AS		1	Refer to #11
8		SWITCH P RELAY AS		1	Refer to #10
9	4005G17020	CEC	PA-6 ID2.3	3	
10	3010200100	BAG HRNS	PE 0.05T	1	
11	3016004120	SPECIAL WASR	SPG T0.8	3	
12	3010309850	BASE COMP	SBHG T0.8	1	
13	3010102910	ABSORBER COMP	NBR	4	
14		COMPRESSOR		1	Refer to # 10
15	7147501011	SCREW TAPPING	T2 5X10 MFZN	2	
16	7122501211	SCREW TAPPING	T2S TRS 5X12 MFZN	2	
17		DRYER AS	NON CFC 8g	1	Refer to #10
18	3010502904	BOX CONTROL	HIPS	1	
19	4006D70027	KNOB	HIPS	1	
20		THERMOSTAT		1	Refer to #10
21	7112402011	SCREW TAPPING	T1 TRS 4X20 MFZN	1	
22	4016V53212	DOOR F	HIPS	1	
23		ASSY R DOOR TOTAL		1	
24	3019024700	POCKET BAR	PVC-H	3	
25	3012316700	GASKET DR AS	PVC	1	
26	3012910600	HINGE *T S	FRM-123	1	
27	7051501611	SCREW MACHINE	PAN 5X16 SW MFZN	2	
28	3011409400	COVER *T HINGE	PP	1	
29	3010927900	CAP CAB HOLE	PP	2	OPTION
30	7112401211	SCREW TAPPING	T1 TRS 4X12 MFZN	1	
31	301119A630	CASE WATER	ABS	1	
32	3011106021	CASE ICING	PP	1	
33	3017800215	SHELF *T	SWM-B PE-COATING	1	
34	3017800255	SHELF *U	SWM-B PE-COATING	1	

EXPLODED VIEW AND PARTS LIST

3. FN-146R

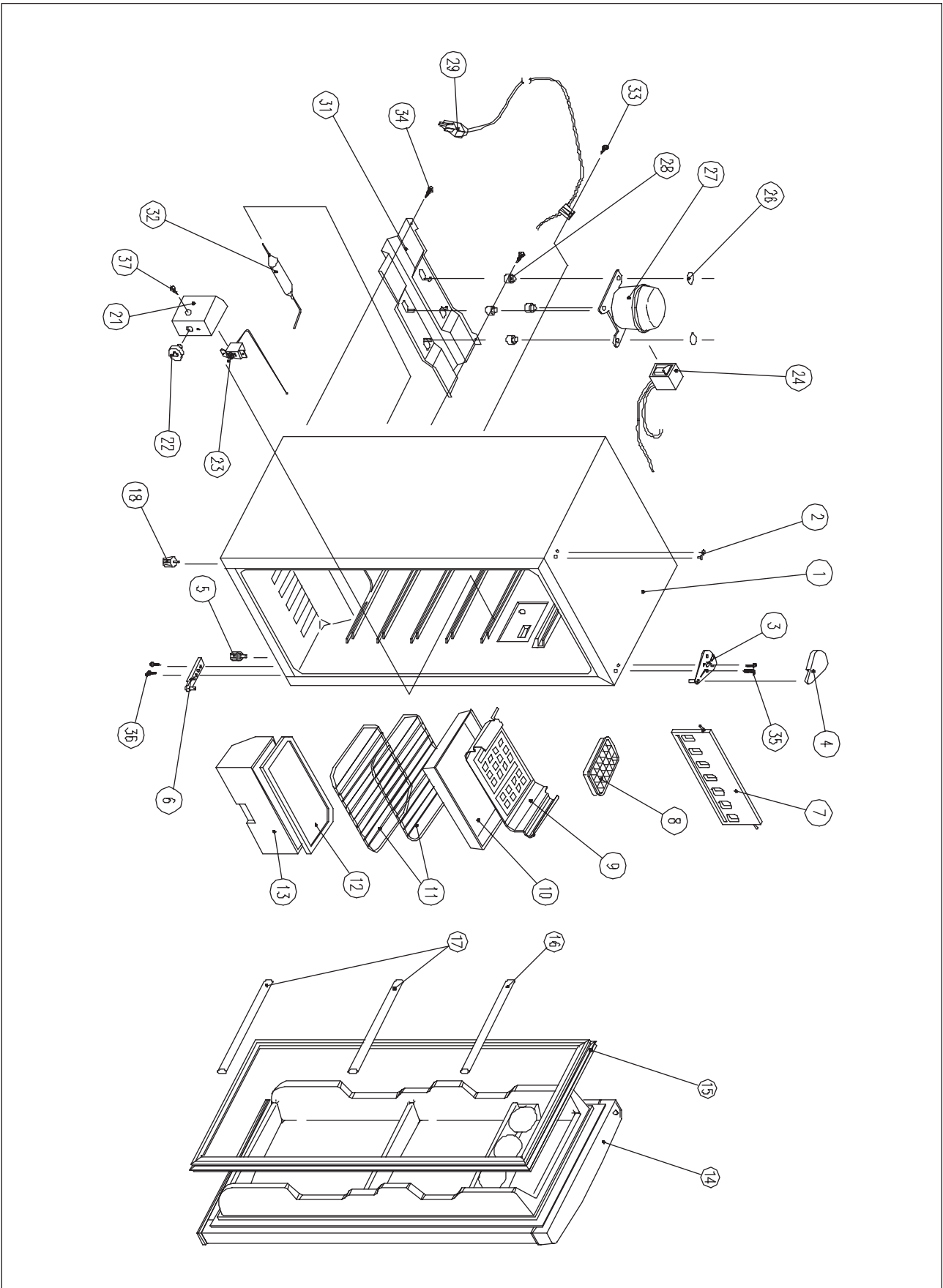

EXPLODED VIEW AND PARTS LIST

✓ CAUTION : In this Service Manual, some parts can be changed for improving their performance without notice in the parts list. So, if you need the latest parts information, please refer to PPL(Parts Price List)in Service information Center(<http://svc.dwe.co.kr>)

NO	PART CODE	PART NAME	DESCRIPTION	QUANTITY	REMARK
1		ASSY CAB PRE	FRM-13	1	
2	3010927900	CAP CAB HOLE	FRM-13	2	OPTION
3	3012910600	HINGE *T AS	FRM-123	1	
4	3011409400	COVER *T HINGE	PP FRM-123	1	
5	3012103301	FOOT ADJ AS	PP INSERT	1	
6	3012910500	HINGE CAB	FR-K184BM	1	
7	4017J53213	DOOR F	FRA-12DP	1	
8	3011106021	CASE ICING	PP	1	
9	3017000150	EVAPORATOR AS	FRM-13	1	
10	301119A620	CASE WATER	ABS	1	
11	4017J55226	SHELF	SWRM PE-COATING	1	
12	4018R30421	COVER V/CASE	LG25SP	2	
13	4017L30612	CASE VEGTB	LG25SP-111	1	
14		ASSY ONE DOOR TOTLA		1	Refer to #12
15	3012316800	GASKET DR AS	PVC	1	
16	3019022200	POCKET BAR	PVC-H 58L	1	
17	3019024800	POCKET BAR	PVC-H T1.8 12LL	2	
18	4006D32534	FOOT *F	PP(JI-360)	1	
19	-	-	-	-	-
20	-	-	-	-	-
21	3010502904	BOX CONTL	HIPS	1	
22	4006D70027	KNOB	HIPS	1	
23		THERMOSTAT		1	Refer to #10
24		SWITCH P RELAY AS		1	Refer to #10
26	3016004120	SPECIAL WASR	SPG T0.8	3	
27	3954125Y80	COMPRESSOR		1	Refer to #10
28	3010102910	ABSORBER COMP	NBR	4	
29		CORD POWER AS		1	Refer to #11
31	3010311620	BASE COMP	SBHG T0.8	1	
32	3016801302	DRYER AS	NON CFC 10g	1	
33	7112401011	SCREW TAPPING	T1 TRS 4 X 10 MFZN	1	
34	7122501211	SCREW TAPPING	T2S TRS 5 X 12 MFZN	2	
35	3016000301	SPECIAL SCREW	M5X14 S1018C	2	
36	7147501411	SCREW TAPPING	T2.5 X 14 MFZN	2	
37	7112402011	SCREW TAPPING	T1 TRS 4X20 MFZN	1	

DAEWOO

DAEWOO ELECTRONICS Corp.

1-2.JEO-DONG L-GA,JOONG-GN
SEOUL, KOREA