

VERTY NOVA

SUBMERSIBLE PUMPS WITH INTERNAL FLOAT



TECHNICAL DATA

Operating range:

from 1 to 10m³/h with head up to 9 metres.

Liquid temperature range:

from 0 °C to +35 °C for domestic use.

Pumped liquid: dirty water without fibres.

Pump priming limit:

10-15 mm in manual operation.

Max. immersion depth: 7 metres.

APPLICATIONS

The vertical delivery draining submersible pump is suitable for domestic automatically operated fixed applications, for draining basements and garages that are subject to flooding. Thanks to its compact and easy to handle shape, and the built-in float, it is suitable for particularly small draining wells (minimum 20x20 cm). It may also be used as a portable pump for emergencies such as lifting water from tanks or rivers, emptying swimming pools, fountains, excavations and underpasses. It is also ideal for gardening, and hobby applications in general. This pump can be used with liquids containing solid particles of up to 5 mm in size. The level switch with built-in float allows fixed installation, ensuring automatic operation. With easy access to the float for maintenance purposes, and automatic or manual mode selector. Minimum suction level up to 2/3 mm.

CONSTRUCTION FEATURES OF THE PUMP

Hydro resistant technopolymer pump body, cover, and suction grid.

Stainless steel motor, roto shaft, and bolts and screws.

Threefold seal with interposed rings with oil pre-chamber.

CONSTRUCTION FEATURES OF THE MOTOR

Submersible type continuous duty asynchronous motor.

Stator enclosed in airtight stainless steel casing, with an outer cover that protects the wiring and the capacitor. Rotor running on permanently lubricated ball bearings, oversized to ensure low noise and durability. Built-in thermal-amperometric protection and permanently connected capacitor.

MATERIALS

N.	PARTS*	MATERIALS	
1	FILTER BASE	TECHNOPOLYMER	
2	IMPELLER	TECHNOPOLYMER	
3	NUT	A2 DIN982-UNI7473 STAINLESS STEEL	
4	V. RING	NBR	
5	WASHER	A2 STAINLESS STEEL	
6	FLOAT	TECHNOPOLYMER	
7	OR RING	NBR	
8	DIAPHRAGM	TECHNOPOLYMER	
9	MOTOR	CASE	ALUMINIUM
		ROTOR SHAFT	AISI 416 STAINLESS STEEL UNI EN 10088-1 X12CRS13
10	OR RING	NBR	
11	BODY	TECHNOPOLYMER	

* In contact with the liquid

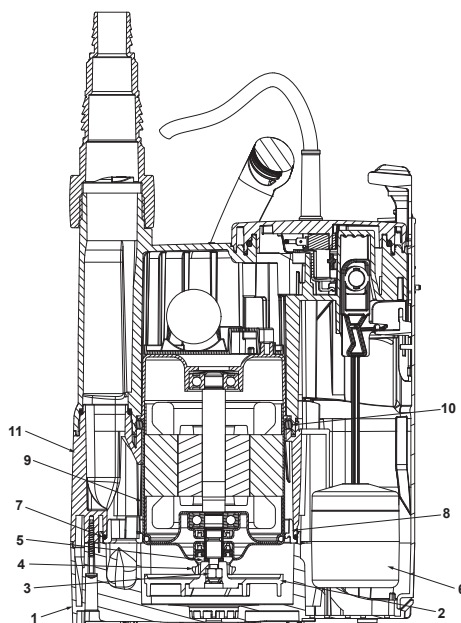

NOVA RANGE

SUBMERSIBLE PUMPS

PERFORMANCE RANGE

The performance curves are based on kinematic viscosity values = 1 mm²/s and density equal to 1000 kg/m³. Curve tolerance according to ISO 9906.

GRAPHIC SELECTION TABLE

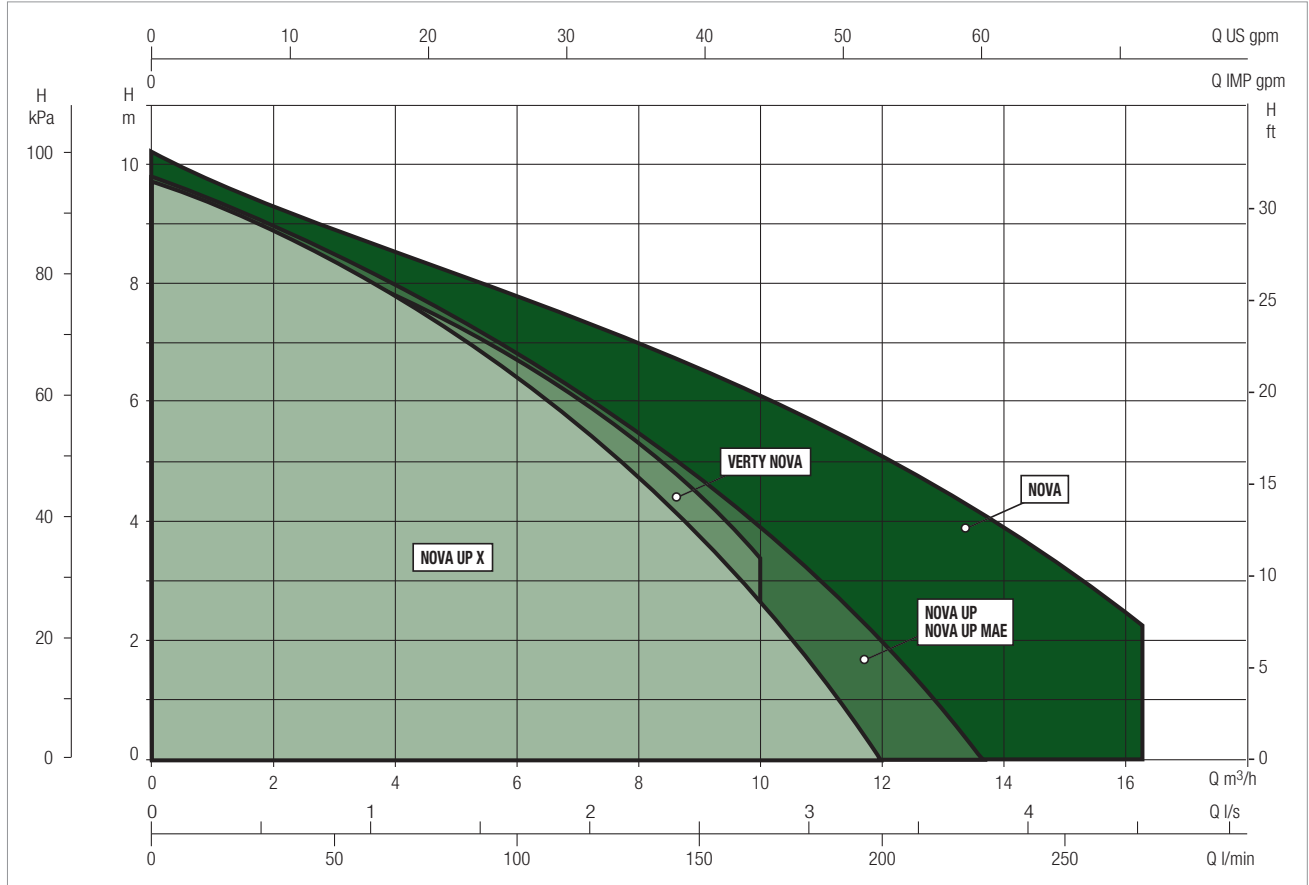

SELECTION TABLE - VERTY NOVA

MODEL	Q= m ³ /h	0	1	2	3	4.5	5	6	7	7.5	9	10	12	13.5	15
	Q=l/min	0	16.6	33.3	50	75	83.3	100	116.6	125	150	166.6	200	225	250
VERTY NOVA 200 M	H (m)	6.9	6.5	6	5.8	4.5	4	3	1.8						
VERTY NOVA 400 M		9	8.8	8.5	8.1	7.8	7	6.7	1.8	5.7	4.2	3.5			

VERTY NOVA - CLEAN WATER DRAINING SUBMERSIBLE PUMPS FOR DOMESTIC USE WITH BUILT-IN FLOAT

Liquid temperature range: from 0 °C to +35 °C for domestic use

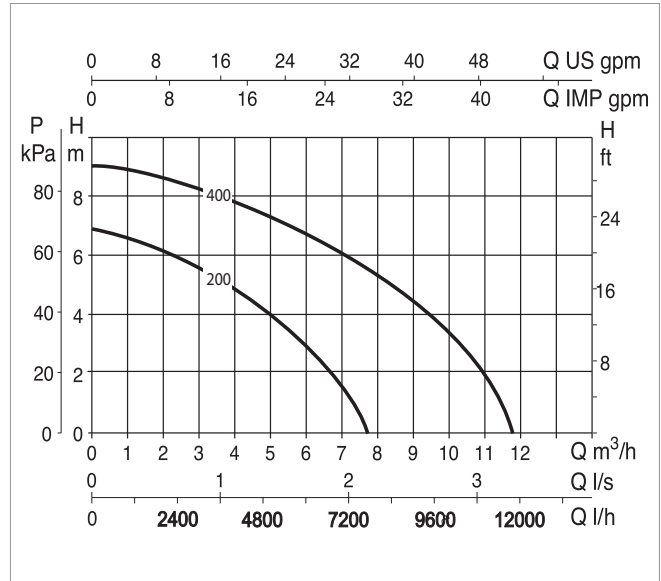
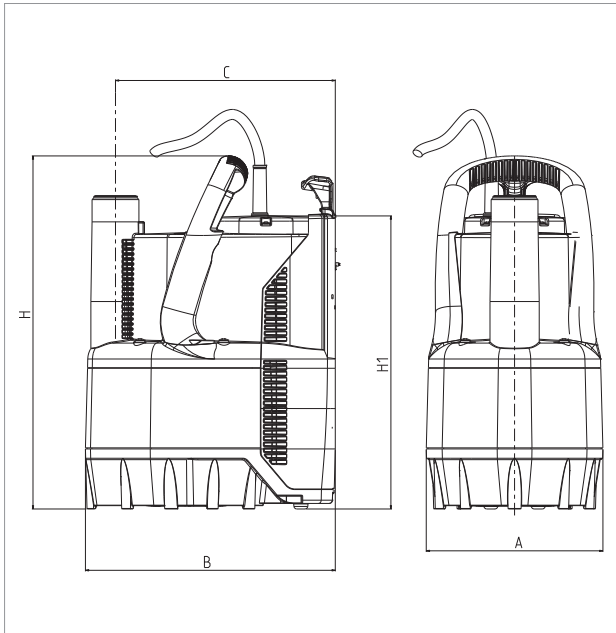

The performance curves are based on kinematic viscosity values = 1 mm²/s and density equal to 1000 kg/m³. Curve tolerance according to ISO 9906.

MODEL	ELECTRICAL DATA				
	POWER INPUT 50 Hz	P1 MAX kW	P2 NOMINAL		In A
			kW	HP	
VERTY NOVA 200 M	1 x 230V ~	0.3	0.2	0.28	1.3
VERTY NOVA 400 M	1 x 230V ~	0.6	0.4	0.55	2.6

MODEL	A	B	C	ØD	H	H1	DNM GAS	PACKING DIMENSIONS			CABLE	VOLUME (m³)	WEIGHT kg
								L/A	L/B	H			
VERTY NOVA 200 M	158	225	200	33	318	265	1" 3/4	222	193	340	10 mt.	0.014	4.2
VERTY NOVA 400 M	158	225	200	33	354	301	1" 3/4	222	193	340	10 mt.	0.014	5.1