

FEKA 4000 /4100/ 4200

SEWAGE PUMPS



SEWAGE AND WASTE WATER

Cast iron submersible pumps with vortex impeller for sewage, suitable for foul waste water with solid contents with 83-98 mm as maximum diameter. Motor body, hydraulic section and any impeller in cast iron EN G.JL 200.

Double mechanical seals in oil chamber: motor side carbon/steel, pump side in silicon carbide/silicon carbide. On request : oil chamber with water level detector kit.

Dry type asynchronous sealed motor. Rotor mounted on ball bearings to ensure silent running and long life. Thermal and overcurrent protection are responsibility of the user; on request available already installed in the motor windings.

- Motor protection rating:** IP 68
- Insulation class:** F
- Continuous duty with completely immersed pump. Supplied as standard with 10 mt H07RN-F power cable.
- Operating range:** from 12 to 180 m³/h with head up to 29 mt.
- Liquid quality requirements:** Non-aggressive sewage, drain water
- Liquid temperature range:** From 0° to + 40°.
- Maximum immersion depth:** 20 mt
- Installation:** portable, in vertical position.
- Free passage:** 83-98 mm.
- Comes with:** UNI 1092 PN 6 compliant flange.
- Lifting device available:** see accessories.

[ACCESSORIES PAG 499](#)
[PANELS PAG 506](#)

TECHNICAL DATA

MODEL	CODE	ELECTRICAL DATA						HYDRAULIC DATA																			
		VOLTAGE 50 HZ	AVV.	P1 MAX kW	P2 NOMINAL		In A	Q=m³/h		H (m)																	
					kW	HP		0	12	18	24	36	48	60	72	90	108	126	150	180							
						Q=l/min	0	200	300	400	600	800	1000	1200	1500	1800	2100	2500	3000								
FEKA 4065.6T D	60141733	3X400 V~	DIRECT	11	4,8	6,4	22,4	8	7,6	7,2	7,1	6,8	6,4	6	5,6	4,7	3,6	2,4									
FEKA 4050. 4T D	60141734	3X400 V~	DIRECT	5	3,8	5,1	9,1	12,7	11,8	11,4	11	9,9	9	8	7	5,4	3,5	1,6									
FEKA 4000.4T D	103018100	3X400 V~	DIRECT	8	6	8	15	15,4	14,9	14,6	14,2	13,7	12,9	12	11,2	9,8	8,2	6,6	4,2								
FEKA 4100.4T S/D	103018510	3X400 V~	Y/Δ	9	7,5	10	16,6	17	16,7	16,4	16	15,3	14,8	13,8	12,9	11,4	9,9	8,2	6,1	3,5							
FEKA 4120. 4T S/D	60141735	3X400 V~	Y/Δ	14	8,75	11,7	25,8	21	20,6	20,3	20	19,5	18,9	18,2	17,6	16,4	14,8	13,1	11	8,2							
FEKA 4100.2T S/D	103018430	3X400 V~	Y/Δ	14	7	9,3	27,4	24	22,4	21,5	20,5	18,3	16,2	14,2	12,3	9,5	6,2										
FEKA 4125.2T S/D	103018470	3X400 V~	Y/Δ	20	8	10,7	33	27	25,3	24,4	23,5	21,3	19,5	17,3	15,3	12,4	9,8										
FEKA 4150.2T S/D	103018560	3X400 V~	Y/Δ	22,8	10,8	14,4	37,8	31	28	26,9	25,8	23,8	22	20	18,2	14,8											
FEKA 4180. 2T S/D	60141736	3X400 V~	Y/Δ	25,3	13,1	17,5	40,8	35	34,2	33,3	32,3	29,8	27	24,4	22	18	14										
FEKA 4200.2T S/D	103018570	3X400 V~	Y/Δ	29,6	15	20	47,6	40	38,5	37,6	36,6	34,3	32	29,8	27,6	23,5	18										

SUBMERSIBLE PUMPS



FEKA 4000 /4100/ 4200

SEWAGE PUMPS

FEKA 4000 - 4100 - 4200

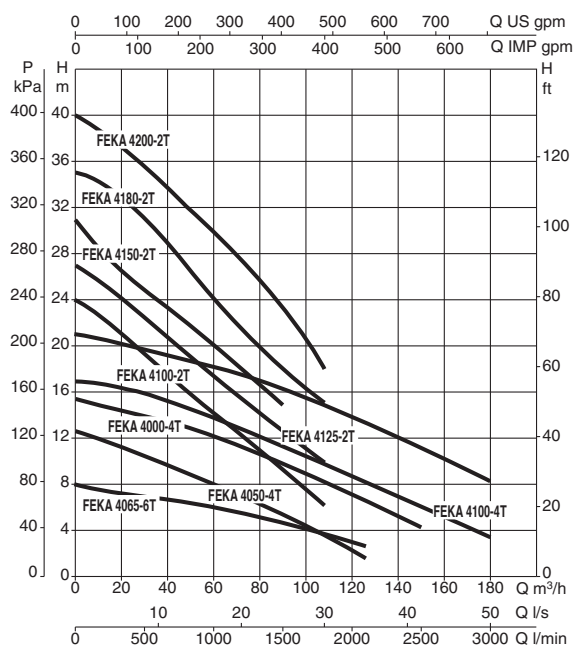

DIMENSIONS AND WEIGHTS

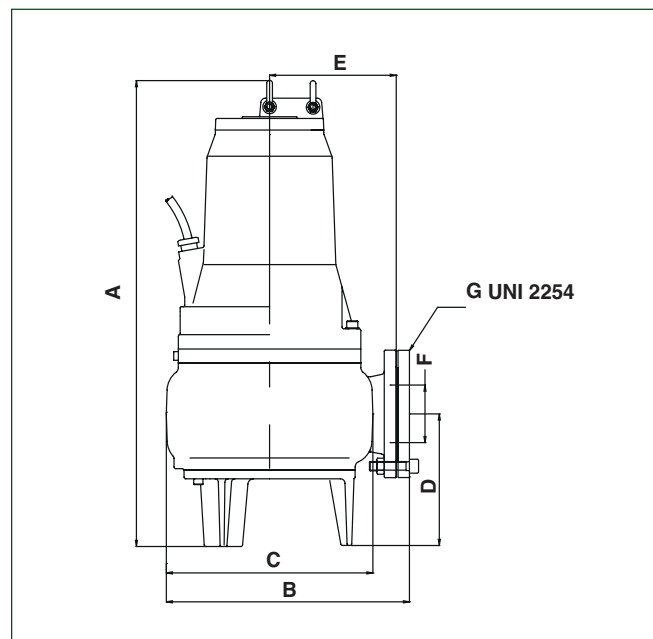

MODELLO	A	B	C	D	E	F	G	FREE PASSAGE mm	WEIGHT KG
FEKA 4065.6T D	774	410	366	227	225	100	Ø 4"	98	143
FEKA 4050.4T D	774	410	366	227	225	100	Ø 4"	98	138
FEKA 4000.4T D	774	410	366	227	225	100	Ø 4"	98	149
FEKA 4100.4T S/D	774	410	366	227	225	100	Ø 4"	98	158
FEKA 4120.4T S/D	774	410	366	227	225	100	Ø 4"	98	160
FEKA 4100.2T S/D	774	410	366	227	225	100	Ø 4"	98	142
FEKA 4125.2T S/D	774	410	366	227	225	100	Ø 4"	98	148
FEKA 4150.2T S/D	874	410	366	227	225	100	Ø 4"	98	160
FEKA 4180.2T S/D	874	410	366	227	225	100	Ø 4"	98	196
FEKA 4200.2T S/D	874	410	366	227	225	100	Ø 4"	98	200

SPECIAL VERSIONS

MODEL	CODE
VERSION WITH THERMAL PROTECTION	on request
VERSION WITH WATER LEVEL DETECTOR	on request