

Installation and Operating Instructions



SP Series Borehole Submersible Pumps



These instructions apply to STAIRS submersible pumps, type SP fitted with Franklin 4"-8" motors. If the pump is fitted with a motor of another motor make than Franklin motors, please note that the motor data may differ from the data stated in these instructions. Read these instructions carefully before beginning installation

1. Delivery and storage

1.1 Delivery

STAIRS submersible pumps are supplied from the factory in proper packing in which they should remain until they are to be installed. During unpacking and prior to installation, care must be taken when handling the pump to ensure that misalignment does not occur due to bending.

CAUTION

The pumps should remain in the packing until They are placed in vertical position during installation.

NOTE

The loose data plate supplied with the pump should be fixed close to the installation site.

The pump should not be exposed to unnecessary impact and shocks.

1.2 Storage and handling

Storage temperature

Pump: -20 °C to +60 °C.

Motor: -20 °C to +70 °C.

The motors must be stored in a closed, dry and well ventilated room. The pump should not be exposed to direct sunlight. If the pump has been unpacked, it should be stored horizontally, adequately supported, or vertically to prevent misalignment of the pump. Make sure that the pump cannot roll or fall over. During storage, the pump can be supported as shown in fig. 1.

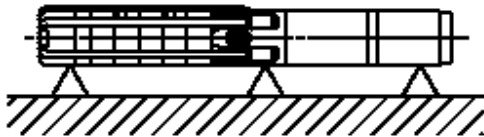

Fig. 1 Pump position during storage

1.2.1 Frost protection

If the pump has to be stored after use, it must be stored on a frost-free location, or it must be ensured that the motor liquid is frost-proof.

2. General data

2.1 Applications

STAIRS SP submersible pumps are designed for a wide range of water supply and liquid transfer applications, such as the supply of fresh water to private homes or waterworks, water supply to nursery gardens or farms, drawdown of groundwater and pressure boosting, and various industrial jobs.

The pump must be installed so that the suction interconnector is completely submerged in the liquid. The pump can be installed either horizontally or vertically.

2.2 Pumped liquids

Clean, thin, **non-explosive** liquids without solid particles or fibres. The maximum sand content of the water must not exceed 50 g/m³. A larger sand content will reduce the life of the pump and increase the risk of blocking.

CAUTION

When pumping liquids with a density higher than that of water, motors with correspondingly higher out puts must be used.

3. Preparation



Warning

Before starting work on the pump, make sure that the electricity supply has been switched off and that it cannot be accidentally switched on.

3.1 Checking of liquid in motor

The submersible motors are factory-filled with a special nonpoisonous liquid, which is frost-proof down to -20 °C.

NOTE

The level of the liquid in the motor must be checked and the motor must be refilled, if required. Use clean water.

Refilling of liquid is carried out according to the instruction and operation manual of motor supplier. Please contact the motor supplier for the refilling information.

3.1.1 Maximum liquid temperature

Out of consideration for the rubber parts in pump and motor, the liquid temperature must not exceed 40 °C (~105 °F). The pump can operate at liquid temperatures between 40 °C and 60 °C (~105 °F and 140 °F) provided that all rubber parts are replaced every third year.

4. Electrical connection



Warning

Before starting work on the pump, make sure that the electricity supply has been switched off and that it cannot be accidentally switched on.

4.1 General

The electrical connection should be carried out by an authorized electrician in accordance with local regulations. The supply voltage, rated maximum current and cos. φ appear from the loose data plate that **must** be fitted close to the installation site.



Warning

The pump must be earthed. The pump must be connected to an external mains switch with a minimum contact gap of 3 mm in all poles. of cooling liquid past the motor is no longer ensured.

For the motor protection, connection and various settings, please refer to the IO manual from your motor supplier.

5. Pump installation

5.1 Fitting the motor to the pump

When the pump part and the motor are supplied as separate units (long pumps), fit the motor to the pump as follows:

1. Use pipe clamps when handling the motor.
2. Place the motor in vertical position at the borehole seal, see fig. 2

Fig. 2 Motor in vertical position

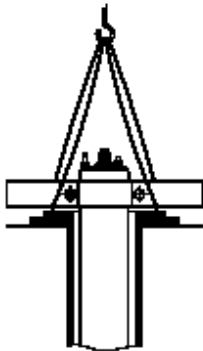

3. Lift the pump part by means of pipe clamps fitted to the extension pipe, see fig. 3.

Fig. 3 Lifting the pump into position

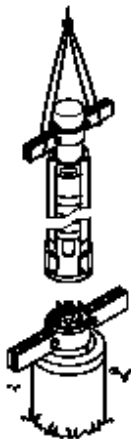

4. Place the pump part on top of the motor.
5. Fit and tighten the nuts, see the table below.

CAUTION *Make sure that the coupling between the pump and motor engages properly.*

The bolts and nuts securing the straps to the pump must be tightened diagonally to the torques stated in the following table:

Straps bolt/nut	Torque [Nm]
M8	18
M10	35
M12	45
M16	120
SP 215, 50 Hz, with more than 8 stages SP 215, 60 Hz, with more than 5 stages	150

When fitting the motor to the pump part, the nuts must be tightened diagonally to the torques stated in the following table:

Pump/motor staybolt diameter	Torque [Nm]
3/8 UNF	18
1/2 UNF	50
M8	18
M12	70
M16	150
M20	280

CAUTION *Make sure that the pump chambers are aligned when assembly has been completed.*

5.2 Removal and fitting of cable guard

For removal and fitting of cable guard(s), see our assembly instruction.

CAUTION *Make sure that the pump chambers are aligned when the cable guard has been fitted.*

5.3 Fitting of submersible drop cable

5.3.1 Grundfos submersible motors

Before fitting the submersible drop cable to the motor, make sure that the cable socket is clean and dry. To facilitate the fitting of the cable, lubricate the rubber parts of the cable plug with non-conducting silicone paste.

5.4 Riser pipe

If a tool, e.g. a chain pipe wrench, is used when the riser pipe is fitted to the pump, the pump must only be gripped by the pump discharge chamber. The threaded joints on the riser pipe must all be well cut and fit together to ensure that they do not work loose when subjected to torque reaction caused by the starting and stopping of the pump. The thread on the first section of the riser pipe which is to be screwed into the pump should not be longer than the threads in the pump. If noise may be transmitted to the building through the pipework, it is advisable to use plastic pipes.

CAUTION *Plastic pipes are recommended for 4" pumps*

When plastic pipes are used, the pump should be secured by an unloaded straining wire to be fastened to the discharge chamber of the pump, see fig. 4.

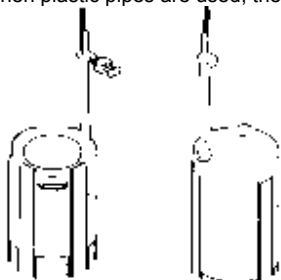

Fig. 4 Fixing the straining wire

When connecting plastic pipes, a compression coupling should be used between the pump and the first pipe section. Where flanged pipes are used, the flanges should be slotted to take the submersible drop cable and a water indicator hose, if fitted.

5.5 Lowering the pump

It is recommended to check the borehole by means of an inside calliper before lowering the pump to ensure unobstructed passage. Lower the pump carefully into the borehole, taking care not to damage the motor cable and the submersible drop cable.

CAUTION *Do not lower or lift the pump by means of the motor cable.*

6. Start-up and operation

6.1 Start-up

When the pump has been connected correctly and it is submerged in the liquid to be pumped, it should be started with the discharge valve closed off to approx. 1/3 of its maximum volume of water. Check the direction of rotation. If there are impurities in the water, the valve should be opened gradually as the water becomes clearer. The pump should not be stopped until the water is completely clean, as otherwise the pump parts and the non-return valve may choke up. As the valve is being opened, the drawdown of the water level should be checked to ensure that the pump always remains submerged.

The dynamic water level should always be above the suction interconnector of the pump.

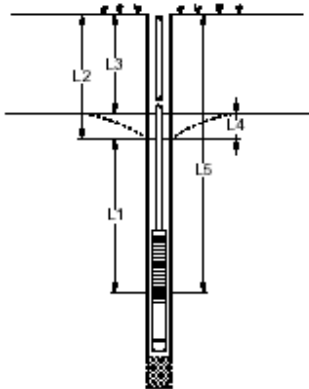

Fig. 5 Comparison of various water levels

L1: Minimum installation depth below dynamic water level. Minimum 1 metre is recommended.

L2: Depth to dynamic water level.

L3: Depth to static water level.

L4: Drawdown. This is the difference between the dynamic and the static water levels.

L5: Installation depth.

If the pump can pump more than yielded by the well, it is recommended to fit the dry-running protection. If no water level electrodes or level switches are installed, the water level may be drawn down to the suction interconnector of the pump and the pump will then draw in air.

CAUTION *Long time operation with water containing air may damage the pump and cause insufficient cooling of the motor.*

7. Maintenance and service

The pumps are maintenance-free. All pumps are easy to service. Service kits and service tools are available from Stairs.

Fault	Cause	Remedy
1. The pump does not run.	a) The fuses are blown.	Replace the blown fuses. If the new ones blow too, the electric installation and the submersible drop cable should be checked.
	b) The ELCB or the voltage-operated ELCB has tripped out.	Cut in the circuit breaker.
	c) No electricity supply.	Contact the electricity supply authorities.
	d) The motor starter overload has tripped out.	Reset the motor starter overload (automatically or possibly manually). If it trips out again, check the voltage. Is the voltage OK, see items e) - h).
	e) Motor starter/contactor is defective.	Replace the motor starter/contactor.
	f) Starter device is defective.	Repair/replace the starter device.
	g) The control circuit has been interrupted or is defective.	Check the electric installation.
	h) The dry-running protection has cut off the the electricity supply to the pump, due to low water level.	Check the water level. If it is OK, check the water level electrodes/level switch.
	i) The pump/submersible drop cable is defective.	Repair/replace the pump/cable.
2. The pump runs but gives no water.	a) The discharge valve is closed.	Open the valve.
	b) No water or too low water level in borehole.	See item 3 a).
	c) The non-return valve is stuck in its shut position.	Pull out the pump and clean or replace the valve.
	d) The inlet strainer is choked up.	Pull out the pump and clean the strainer.
	e) The pump is defective.	Repair/replace the pump.
3. The pump runs at reduced capacity.	a) The drawdown is larger than anticipated.	Increase the installation depth of the pump, throttle the pump or replace it by a smaller model to obtain a smaller capacity.
	b) Wrong direction of rotation.	See section 5.7.1 <i>Checking of direction of rotation.</i>
	c) The valves in the discharge pipe are partly closed/blocked.	Check and clean/replace the valves, if necessary.
	d) The discharge pipe is partly choked by impurities (ochre).	Clean/replace the discharge pipe.
	e) The non-return valve of the pump is partly blocked.	Pull out the pump and check/replace the valve.
	f) The pump and the riser pipe are partly choked by impurities (ochre).	Pull out the pump. Check and clean or replace the pump, if necessary. Clean the pipes.
	g) The pump is defective.	Repair/replace the pump.
	h) Leakage in the pipework.	Check and repair the pipework.
	i) The riser pipe is defective.	Replace the riser pipe.
4. Frequent starts and stops.	a) The differential of the pressure switch between the start and stop pressures is too small.	Increase the differential. However, the stop pressure must not exceed the operating pressure of the pressure tank, and the start pressure should be high enough to ensure sufficient water supply.
	b) The water level electrodes or level switches in the reservoir have not been installed correctly.	Adjust the intervals of the electrodes/level switches to ensure suitable time between the cutting-in and cutting-out of the pump. See installation and operating instructions for the automatic devices used. If the intervals between stop/start cannot be changed via the automatics, the pump capacity may be reduced by throttling the discharge valve.
	c) The non-return valve is leaking or stuck half-open.	Pull out the pump and clean/replace the non-return valve.
	d) The volume of air in the pressure/diaphragm tank is too small.	Adjust the volume of air in the pressure/diaphragm tank in accordance with its installation and operating instructions.
	e) The pressure/diaphragm tank is too small.	Increase the capacity of the pressure/diaphragm tank by replacing or supplementing with another tank.
	f) The diaphragm of the diaphragm tank is defective.	Check the diaphragm tank.



STAIRS INDUSTRIAL CO., LTD.

No. 3-8, Sanchial Tsun, Lutsao Hsiang

Chiai Hsien, Taiwan, R.O.C.

Tel: +886 (0) 53750488

Fax: +886 (0) 53752330

E-Mail: stairs@stairs.com.tw