



Return to the
Table of Contents

TIG welding electrodes

w, wl20,
wc20,
goldplus on
stock . beste
price



Lesson 7

Shielded Metal-Arc Welding and Wearfacing

The shielded metal-arc welding process, referred to as metallic-arc welding, arc welding, or stick welding, is extensively used in welding ferrous and nonferrous metals. It has many applications for producing a vast assortment of metal products. Shielded metal-arc welding

is found in the ship building industry and in the construction industry for fabricating girders, beams, and columns. Because it is easy to use and portable, shielded metal-arc welding is universally used in the repair and servicing of equipment, machinery, and a host of other items.

Manual Shielded Metal-Arc Welding

Arc welding provides you the ability to join two metals by melting them with an arc generated between a coated-metal electrode and the base metal. The temperatures developed by the arc can reach as high as 10000°F. The arc energy is provided by a power source that generates either direct or alternating current. The electrodes that carry the current produce a gas that shields the arc from the atmosphere and supplies filler metal to develop the weld shape.

ARC-WELDING EQUIPMENT

A wide variety of welding equipment is available, and there are many differences between the makes and models of the equipment produced by the manufacturers. However, all types of arc-welding equipment are similar in their basic function of producing the high-amperage, low-voltage electric power required for the welding arc. In this discussion, we are primarily concerned with the typical items of arc-welding equipment, rather than the specific types. For specific information about the equipment, consult the manufacturer's instruction manual.

The basic parts of a typical shielded metal-arc welding outfit include a welding machine, cables, electrode holder (stinger), and electrodes. The welder also requires a number of accessories that include a combination chipping hammer and wire brush, welding table (for shopwork), C-clamps, and protective apparel.

Before we discuss the different types of welding machines, you must first have a basic knowledge of the electrical terms used with welding.

Electrical Terms

Many terms are associated with arc welding. The following basic terms are especially important.

ALTERNATING CURRENT.— Alternating current is an electrical current that has alternating negative and positive values. In the first half-cycle, the current flows in one direction and then reverses itself for the next half-cycle. In one complete cycle, the current spends 50 percent of the time flowing one way and the other 50 percent flowing the other way. The rate of change in direction is called frequency, and it is indicated by cycles per second. In the United States, the alternating current is set at 60 cycles per second.

AMPERE.— Amperes, sometimes called “amps,” refers to the amount of current that flows through a circuit. It is measured by an “amp” meter.

CONDUCTOR.— Conductor means any material that allows the passage of an electrical current.

CURRENT.— Current is the movement or flow of an electrical charge through a conductor.

DIRECT CURRENT.— Direct current is an electrical current that flows in one direction only.

ELECTRICAL CIRCUIT.— Electrical circuit is the path taken by an electrical current flowing through a conductor from one terminal of the source to the load and returning to the other terminal of the source.

POLARITY.— Polarity is the direction of the flow of current in a circuit. Since current flows in one direction only in a dc welder, the polarity becomes an important factor in welding operations.

RESISTANCE.— Resistance is the opposition of the conductor to the flow of current. Resistance causes electrical energy to be changed into heat.

VOLT.— A volt is the force required to make the current flow in an electrical circuit. It can be compared to pressure in a hydraulic system. Volts are measured with a volt meter.

Power Source

The power source used in arc welding is called a welding machine or a welder. Three basic types of welding machines are presently in use: motor-generators, transformers, and rectifiers.

MOTOR-GENERATOR WELDING MACHINES.— These types of welding machines are powered by electrical, gasoline, or diesel motors. The diesel and gasoline motors are ideal for use in areas where electricity is not available.

These machines usually have the capability of generating alternating or direct current. On the newer machines, when you are welding in the direct-current mode, the polarity can be changed by turning a switch. Some of the older machines require reversing the cable connections. One of the advantages of a direct-current (dc) welding generator is that you have the choice of welding with either straight or reverse polarity.

Welding machines are made in six standardized ratings for general purposes and are listed as follows:

- Machines rated 150 and 200 amperes—30 volts are for light-shielded metal-arc welding and for inert-gas arc welding. They are also for general-purpose jobs or shopwork.
- Machines rated 200,300, and 400 amperes—40 volts are for general welding purposes by machine or manual application.
- Machines rated 600 amperes—40 volts are for submerged-arc welding or carbon-arc cutting.

ALTERNATING-CURRENT TRANSFORMER WELDING MACHINES.— Practically all the alternating current (ac) arc-welding machines in use are the static-transformer type, as shown in figure 7-2. These types of machines are the smallest, least expensive, and the lightest type of welders made. Industrial applications for manual operation use machines having 200, 300, and 400 ampere ratings. Machines with a 150-ampere rating are used in light industrial, garage, and job/shop welding.

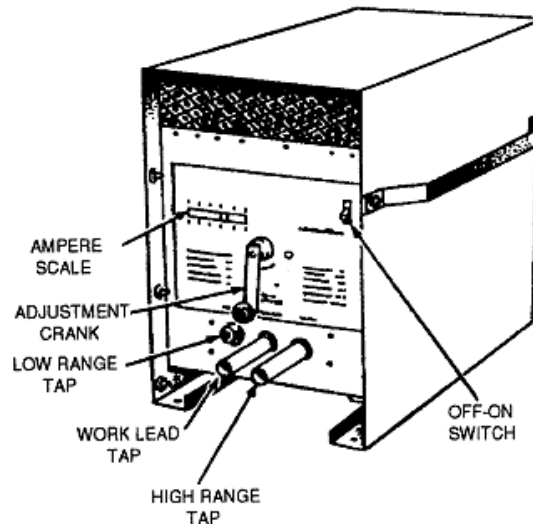

Figure 7-2.—An ac arc-welding transformer.

The transformers are usually equipped with arc-stabilizing capacitors. Current control is provided in several ways by the welding transformer manufacturers. One such method is an adjustable reactor that is set by turning a crank until the appropriate setting is found. Another method is by plugging the electrode cable into different sockets located on the front of the machine.

One major advantage of ac transformers is the freedom from arc blow, which often occurs when welding with direct-current (dc) machines. Arc blow causes the arc to wander while you are welding in corners on heavy metal or using large coated electrodes.

RECTIFIER WELDING MACHINES.— Rectifier welders are single-phase or three-phase transformers that have selenium or silicon rectifiers added to rectify (change) the output current from alternating to direct current. Most of these machines have the capability of producing either ac or dc straight or reverse polarity current. By flicking a switch, the welder can select the current that best suits the job. Figure 7-3 shows an example of a combination ac/dc rectifier.

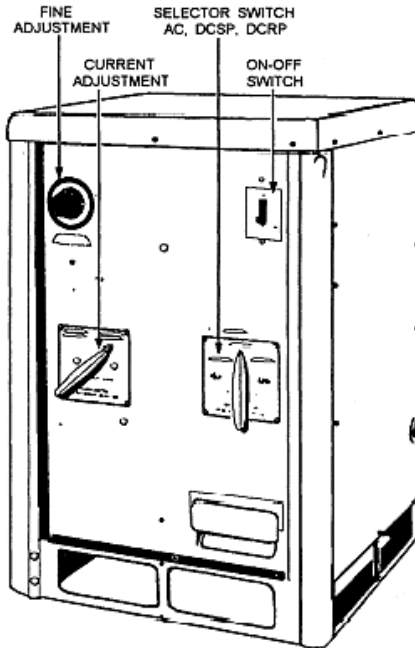

Figure 7-3.—Combination ac, dc transformer-rectifier arc welder.

Cables

Welding cables carry the current to and from the workpiece. One of the cables runs from the welding machine to the electrode holder and the other cable connects the workpiece to the welding machine. The cable that connects the workpiece to the welding machine is called the ground. When the machine is turned on and the operator touches the electrode to the workpiece, the circuit is completed, current begins to flow, and the welding process commences.

The welding cables must be flexible, durable, well insulated, and large enough to carry the required current. Only cable that is specifically designed for welding should be used. A highly flexible cable must be used for the electrode holder connection. This is necessary so the operator can easily maneuver the electrode holder during the welding process. The ground cable need not be so flexible because once it is connected, it does not move.

Two factors determine the size of welding cable to use: the amperage rating of the machine and the distance between the work and the machine. If either amperage or distance increases, the cable size also must increase. (See table 7-1.) A cable that is too small for the amperage or the distance between the machine and the work will overheat. On the other hand, larger size cables are more difficult to handle, especially if you are working on a structure that requires a lot of moving around. The best size cable is one that meets the amperage demand but is small enough to manipulate with ease.

Table 7-1.—Cable Size Selection Guide

Current Amp	Distance from welder (Total length of electrode and ground cables divided by two)											
	50'	75'	100'	125'	150'	175'	200'	225'	250'	300'	350'	400'
100	4	4	2	2	1	1/0	1/0	2/0	2/0	3/0	4/0	4/0
150	4	2	1	1/0	2/0	3/0	3/0	4/0	4/0			
200	2	1	1/0	2/0	3/0	4/0	4/0					
250	1	1/0	2/0	3/0	4/0							
300	1/0	2/0	3/0	4/0								
350	1/0	2/0	4/0									
400	1/0	3/0	4/0									
450	2/0	3/0										
500	2/0	4/0										
550	3/0											
600	3/0											

Based on a 4-Volt Drop

As a rule, the cable between the machine and the work should be as short as possible. Use one continuous length of cable if the distance is less than 35 feet. If you must use more than one length of cable, join the sections with insulated lock-type cable connectors. Joints in the cable should be at least 10 feet away from the operator.

Electrode Holder

An electrode holder, commonly called a stinger, is a clamping device for holding the electrode securely in any position. The welding cable attaches to the holder through the hollow insulated handle. The design of the electrode holder permits quick and easy electrode exchange. Two general types of electrode holders are in use: insulated and noninsulated. The noninsulated holders are not recommended because they are subject to accidental short circuiting if bumped against the workpiece during welding. For safety reasons, try to ensure the use of only

insulated stingers on the jobsite.

Electrode holders are made in different sizes, and manufacturers have their own system of designation. Each holder is designed for use within a specified range of electrode diameters and welding current. You require a larger holder when welding with a machine having a 300-ampere rating than when welding with a 100-ampere machine. If the holder is too small, it will overheat

Ground Clamps

The use of a good ground clamp is essential to producing quality welds. Without proper grounding, the circuit voltage fails to produce enough heat for proper welding, and there is the possibility of damage to the welding machine and cables. Three basic methods are used to ground a welding machine. You can fasten the ground cable to the workbench with a C-clamp (fig. 7-4), attach a spring-loaded clamp (fig. 7-5) directly onto the workpiece, or bolt or tack-weld the end of the ground cable to the welding bench (fig. 7-6). The third way creates a permanent common ground.

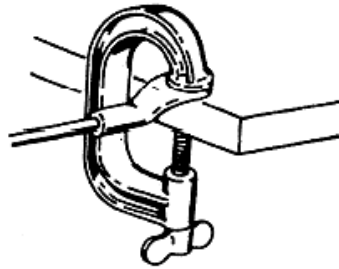

Figure 7-4.—C-clamped ground cable.

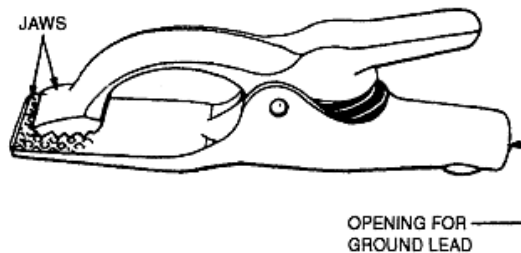

Figure 7-5.—A spring-loaded ground clamp for the ground lead.

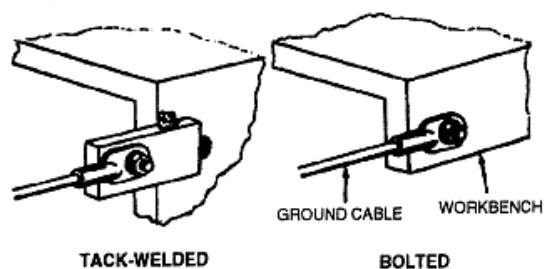

Figure 7-6.—Bolted and tack-welded ground clamps.

Cleaning Equipment

Strong welds require good preparation and procedure. The surface area of the workpiece must be free of all foreign material, such as rust, paint, and oil. A steel brush is an excellent cleaning tool and is an essential part of the welder's equipment. After initial cleaning and a weld bead has been deposited, the slag cover must be removed before additional beads are added. The chip-ping hammer was specifically designed for this task. The chipping operation is then followed by more brushing, and this cycle is repeated until the slag has been removed. When the slag is not removed, the result is porosity in the weld that weakens the weld joint.

Cleaning can also be accomplished by the use of power tools or chemical agents. If these items are used, it is essential that all safety precautions are followed.

Safety Equipment

Arc welding not only produces a brilliant light, but it also emits ultraviolet and infrared rays that are very dangerous to your eyes and skin. Personal safety items include helmets, lenses, and gloves. An important item that needs to be covered here is welding screens. The welder not only has to protect himself but he also must take precautions to protect other people who may be working close by. When you are welding in the field, you must install a welding screen around your work area. It can be an elaborate factory-manufactured screen or as simple as one constructed on site from heavy fire-resistant canvas.

WARNING

Never look at the welding arc without protection. Looking at the arc with the naked eye could result in permanent eye damage. If you receive flash burns, they should be treated by medical personnel.

Another area often overlooked is ventilation. Welding produces a lot of smoke and fumes that can be injurious to the welder if they are allowed to accumulate. This is especially true if you are welding in a tank or other enclosed area. Permanent welding booths should be equipped with an exhaust hood and fan system for removal of smoke and fumes.

Equipment Operation and Maintenance

Learning to arc weld requires you to possess many skills. Among these skills are the abilities to set up, operate, and maintain your welding equipment.

WELDING AREA REQUIREMENTS

In most factory environments, the work is brought to the welder. In the Seabees, the majority of the time the opposite is true. You will be called to the field for welding on buildings, earthmoving equipment, well drilling pipe, ship to shore fuel lines, pontoon causeways, and the list goes on. To accomplish these tasks, you have to become familiar with your equipment and be able to maintain it in the field. It would be impossible to give detailed maintenance information here because of the many different types of equipment found in the field; therefore, only the highlights will be covered.

WELDING MACHINE OPERATION AND MAINTENANCE

You should become familiar with the welding machine that you will be using. Study the manufacturer's literature and check with your senior petty officer or chief on the items that you do not understand. Machine setup involves selecting current type, polarity, and current settings. The current selection depends on the size and type of electrode used, position of the weld, and the properties of the base metal.

Cable size and connections are determined by the distance required to reach the work the size of the machine, and the amperage needed for the weld.

Operator maintenance depends on the type of welding machine used. Transformers and rectifiers require little maintenance compared to engine-driven welding machines. Transformer welders require only to be kept dry and a minimal amount of cleaning. Internal maintenance should only be done by electricians due to the possibilities of electrical shock. Engine-driven machines require daily maintenance of the motors. In most places you will be required to fill out and turn in a daily inspection form called a "hard card" before starting the engine. This form is a list of items, such as oil level, water level, visible leaks, and other things, that affect the operation of the machine. Transportation departments are the ones who usually handle these forms.

After all of the above items have been checked, you are now ready to start welding.

Shielded-Metal Arc Welding

Before you start to weld, ensure that you have all the required equipment and accessories. Listed below are some additional welding rules that should be followed.

- Clear the welding area of all debris and clutter.
- Do not use gloves or clothing that contains oil or grease.
- Check that all wiring and cables are installed properly.
- Ensure that the machine is grounded and dry.
- Follow all manufacturer's directions on operating the welding machine.
- Have on hand a protective screen to protect others in the welding area from FLASH burns.
- Always keep fire-fighting equipment on hand.
- Clean rust, scale, paint, or dirt from the joints that are to be welded.

ELECTRODES

In general, all electrodes are classified into five main groups:

- Mild steel
- High-carbon steel
- Special alloy steel

- Cast iron
- Nonferrous

The widest range of arc welding is done with electrodes in the mild steel group.

Electrodes are manufactured for use in specific positions and for many different types of metal. They also are specially designed to use with ac or dc welding machines. Some manufacturer's electrodes work identically on either ac or dc, while others are best suited for flat-position welding. Another type is made primarily for vertical and overhead welding, and some can be used in any position. As you can see, electrode selection depends on many variables.

Types of Electrodes

Electrodes are classified as either bare or shielded. The original bare electrodes were exactly as their name implied—bare. Today, they have a light covering, but even with this improvement they are rarely used because of their limitations. They are difficult to weld with, produce brittle welds, and have low strength. Just about all welding is done with shielded electrodes.

The shielded electrode has a heavy coating of several chemicals, such as cellulose, titania sodium, low-hydrogen sodium, or iron powder. Each of the chemicals in the coating serves a particular function in the welding process. In general, their main purposes are to induce easier arc starting, stabilize the arc, improve weld appearance and penetration, reduce spatter, and protect the molten metal from oxidation or contamination by the surrounding atmosphere.

As molten metal is deposited in the welding process, it attracts oxygen and nitrogen. Since the arc stream takes place in the atmosphere, oxidation occurs while the metal passes from the electrode to the work. When this happens, the strength and ductility of the weld are reduced as well as the resistance to corrosion. The coating on the electrode prevents oxidation from taking place. As the electrode melts, the heavy coating releases an inert gas around the molten metal that excludes the atmosphere from the weld (fig. 7-7).

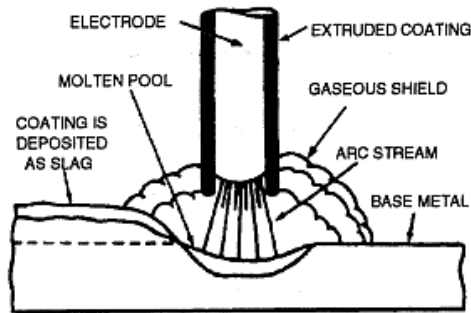

Figure 7-7.—Electrode covering and gaseous shield that protects weld metal from the atmosphere.

The burning residue of the coating forms a slag over the deposited metal that slows down the cooling rate and produces a more ductile weld. Some coatings include powdered iron that is converted to steel by the intense heat of the arc as it flows into the weld deposit.

Electrode Identification

Electrodes are often referred to by a manufacturer's trade name. The American Welding Society (AWS) and the American Society for Testing and Materials (ASTM) have set up certain requirements for electrodes to assure some degree of uniformity in manufacturing electrodes. Thus different manufacturer's electrodes that are within the classification established by the AWS and ASTM should have the same welding characteristics. (See fig. 7-8.)

All mild steel and low-alloy electrodes are classified with a 4 or 5 digit number prefixed by "E."

Prefix "E" = Electrode

First two (or three) digits = Tensile strength (psi) (stress relieved or as welded)

Third (or fourth) digit = Position of welding

1 = all positions (flat, horizontal, vertical, overhead)

2 = horizontal and flat positions only

FOURTH DIGIT	TYPE OF COATING	WELDING CURRENT
1	cellulose potassium	ac or dc Reverse or Straight
2	titania sodium	ac or dc Straight
3	titania potassium	ac or dc Straight or Reverse
4	iron powder titania	ac or dc Straight or Reverse
5	low hydrogen sodium	dc Reverse
6	low hydrogen potassium	dc or dc Reverse
7	iron powder iron oxide	ac or dc
8	iron powder low hydrogen	dc Reverse or Straight or ac
0*	see reference below	

EXAMPLE

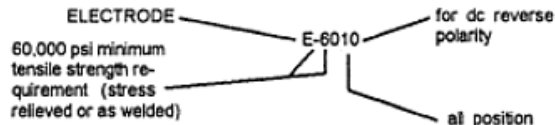

*When the fourth digit is 0, the type of coating and current to use are

Figure 7-8.—Explanation of AWS classification numbers.

In this classification, each type of electrode is assigned a specific symbol, such as E-6010, E-7010, and E-8010. The prefix E identifies the electrode for electric-arc welding. The first two digits in the symbol designate the minimum allowable tensile strength in thousands of pounds per square inch of the deposited metal. The fourth digit of the symbol represents special characteristics of the electrode, such as weld quality, thousands of pounds per square inch of the deposited type of current, and amount of penetration. The numbers range from 0 through 8. For example, the 60-series electrodes have a strength of 60,000 pounds per square inch, while the 70-series electrodes have a strength of 70,000 pounds per square inch. Since the welding position is dependent on the manufacturer's characteristics of the coating, the third and fourth numbers are often identified together.

The third digit of the symbol indicates the joint position for which the electrode is designed. Two numbers are used for this purpose: 1 and 2. Number 1 designates an electrode that can be used for welding in any position. Number 2 represents an electrode restricted for welding in the horizontal and flat positions only.

The fourth digit of the symbol represents special characteristics of the electrode, such as weld quality, type of current, and amount of penetration. The numbers range from 0 through 8. Since the welding position is dependent on the manufacturer's characteristics of the coating, the third and fourth numbers are often identified together.

Electrode Selection

Table 7-2.—Electrode Selection Guide

All mild steel and low-alloy electrodes are classified with a 4 or 5 digit number prefixed by "E."

Prefix "E" = Electrode

First two (or three) digits = Tensile strength (psi) (stress relieved or as welded)

Third (or fourth) digit = Position of welding

1 = all positions (flat, horizontal, vertical, overhead)

2 = horizontal and flat positions only

FOURTH DIGIT	TYPE OF COATING	WELDING CURRENT
1	cellulose potassium	ac or dc Reverse or Straight
2	titania sodium	ac or dc Straight
3	titania potassium	ac or dc Straight or Reverse
4	iron powder titania	ac or dc Straight or Reverse
5	low hydrogen sodium	dc Reverse
6	low hydrogen potassium	dc or dc Reverse
7	iron powder iron oxide	ac or dc
8	iron powder low hydrogen	dc Reverse or Straight or ac
0*	see reference below	

EXAMPLE

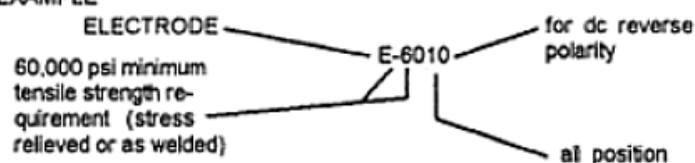

*When the fourth digit is 0, the type of coating and current to use are

Several factors are critical when you choose an electrode for welding. The welding position is particularly significant. Table 7-2 shows the recommended current types and welding positions for the most common electrodes.

As a rule of thumb, you should never use an electrode that has a diameter larger than the thickness of the metal that you are welding. Some operators prefer larger electrodes because they permit faster travel, but this takes a lot of expedience to produce certified welds.

Position and the type of joint are also factors in determining the size of the electrode. For example, in a thick-metal section with a narrow vee, a small-diameter electrode is always used to run the frost weld or root pass. This is done to ensure full penetration at the root of the weld. Successive passes are then made with larger electrodes.

For vertical and overhead welding, 3/16 inch is the largest diameter electrode that you should use regardless of plate thickness. Larger electrodes make it too difficult to control the deposited metal. For economy, you should always use the largest electrode that is practical for the work. It takes about one half of the time to deposit an equal quantity of weld metal from 1/4-inch electrodes as it does from 3/16-inch electrodes of the same type. The larger sizes not only allow the use of higher currents but also require fewer stops to change electrodes.

Deposit rate and joint preparation are also important in the selection of an electrode. Electrodes for welding mild steel can be classified as fast freeze, fill freeze, and fast fill. FAST-FREEZE electrodes produce a snappy, deep penetrating arc and fast-freezing deposits. They are commonly called reverse-polarity electrodes, even though some can be used on ac. These electrodes have little slag and produce flat beads. They are widely used for all-position welding for both fabrication and repair work.

FILL-FREEZE electrodes have a moderately forceful arc and a deposit rate between those of the fast-freeze and fast-fill electrodes. They are commonly called the straight-polarity electrodes, even though they may be used on ac. These electrodes have complete slag coverage and weld deposits with distinct, even ripples. They are the general-purpose electrode for a production shop and are also widely used for repair work. They can be used in all positions, but fast-freeze electrodes are still preferred for vertical and overhead welding.

Among the FAST-FILL electrodes are the heavy-coated, iron powder electrodes with a soft arc and fast deposit rate. These electrodes have a heavy slag and produce exceptionally smooth weld deposits. They are generally used for production welding where the work is positioned for flat welding.

Another group of electrodes are the low-hydrogen type that were developed for welding high-sulfur and high-carbon steel. These electrodes produce X-ray quality deposits by reducing the absorption of hydrogen that causes porosity and cracks under the weld bead.

Welding stainless steel requires an electrode containing chromium and nickel. All stainless steels have low-thermal conductivity that causes electrode over-heating and improper arc action when high currents are used. In the base metal, it causes large temperature differentials between the weld and the rest of the work, which warps the plate. A basic rule in welding stainless steel is to avoid high currents and high heat. Another reason for keeping the weld cool is to avoid carbon corrosion.

There are also many special-purpose electrodes for surfacing and welding copper and copper alloys, aluminum, cast iron, manganese, nickel alloys, and nickel-manganese steels. The composition of these electrodes is designed to match the base metal. The basic rule in selecting electrodes is to pick one that is similar in composition to the base metal.

Electrode Storage

Electrodes are expensive; therefore, the loss or deterioration through improper handling or storage can become very costly. Always store them in a dry place at room temperature with 50-percent maximum relative humidity. Moisture causes the coating on electrodes to disintegrate and fall off. Low-hydrogen rods are especially sensitive to moisture. After removing these rods from their original packaging, you should store them in a storage space maintained at a temperature between 250°F to 400°F. Portable or stationary drying ovens are used to store and preserve electrodes at specified temperatures. Care should be taken when handling electrodes because bumping or dropping them can cause the coatings to fall off, rendering the rod useless.

Polarity

Earlier in this chapter, ac and dc current was briefly covered. With ac welding machines, polarity is not a problem. When using dc welding machines, you can weld with either straight polarity or reverse polarity.

Polarity is the direction of the current flow in a circuit, as shown in figure 7-9. In straight polarity, the electrode is negative and the workpiece positive; the electrons flow from the electrode to the workpiece. In reverse polarity, the electrode is positive and the work-piece negative; the electrons flow from the workpiece to the electrode. To help you remember the difference, think of straight polarity as a **SEN**ator and reverse polarity as a **REP**resentative. Use only the first three letters of each key word. SEN stands for Straight Electrode Negative; REP for Reverse Electrode Positive.

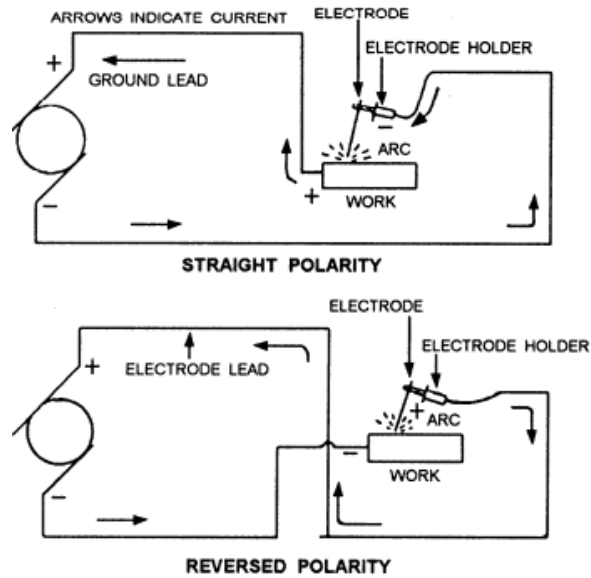

Figure 7-9.—Straight and reverse polarity in electric welding.

On some of the older machines, polarity is changed by switching cables. On many of the newer machines, the polarity can be changed by turning a switch on the machine.

Polarity affects the amount of heat going into the base metal. By changing polarity, you can direct the amount of heat to where it is needed. When you use straight polarity, the majority of the heat is directed toward the workpiece. When you use reverse polarity, the heat is concentrated on the electrode. In some welding

situations, it is desirable to have more heat on the workpiece because of its size and the need for more heat to melt the base metal than the electrode; therefore, when making large heavy deposits, you should use STRAIGHT POLARITY.

On the other hand, in overhead welding it is necessary to rapidly freeze the filler metal so the force of gravity will not cause it to fall. When you use REVERSE POLARITY, less heat is concentrated at the workpiece. This allows the filler metal to cool faster, giving it greater holding power. Cast-iron arc welding is another good example of the need to keep the workpiece cool; reverse polarity permits the deposits from the electrode to be applied rapidly while preventing overheating in the base metal.

In general, straight polarity is used for all mild steel, bare, or lightly coated electrodes. With these types of electrodes, the majority of heat is developed at the positive side of the current, the workpiece. However, when heavy-coated electrodes are used, the gases given off in the arc may alter the heat conditions so the opposite is true and the greatest heat is produced on the negative side. Electrode coatings affect the heat conditions differently. One type of heavy coating may provide the most desirable heat balance with straight polarity, while another type of coating on the same electrode may provide a more desirable heat balance with reverse polarity.

Reverse polarity is used in the welding of nonferrous metals, such as aluminum, bronze, Monel, and nickel. Reverse polarity is also used with some types of electrodes for making vertical and overhead welds.

You can recognize the proper polarity for a given electrode by the sharp, crackling sound of the arc. The wrong polarity causes the arc to emit a hissing sound, and the welding bead is difficult to control.

One disadvantage of direct-current welding is "arc blow." As stated earlier, arc blow causes the arc to wander while you are welding in corners on heavy metal or when using large-coated electrodes. Direct current flowing through the electrode, workpiece, and ground clamp generates a magnetic field around each of these units. This field can cause the arc to deviate from the intended path. The arc is usually deflected forward or backward along the line of travel and may cause excessive spatter and incomplete fusion. It also has the tendency to pull atmospheric gases into the arc, resulting in porosity.

Arc blow can often be corrected by one of the following methods: by changing the position of the ground clamp, by welding away from the ground clamp, or by changing the position of the workpiece.

STARTING THE ARC

Two basic methods are used for starting the arc: the STRIKING or BRUSHING method (fig. 7-10) and the TAPPING method (fig. 7-11). In either method, the arc is started by short circuiting the welding current between the electrode and the work surface. The surge of high current causes the end of the electrode and a small spot on the base metal beneath the electrode to melt instantly.

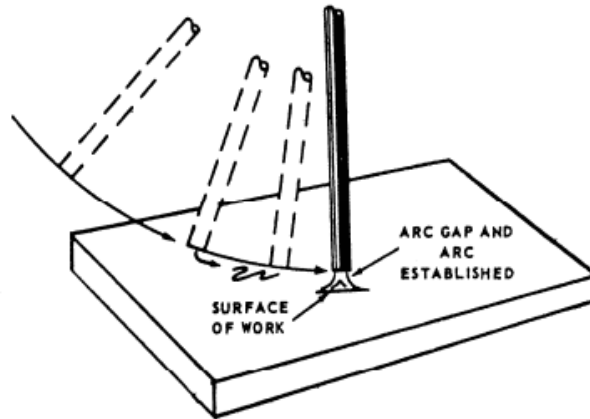

Figure 7-10.—Striking or brushing method of starting the arc.

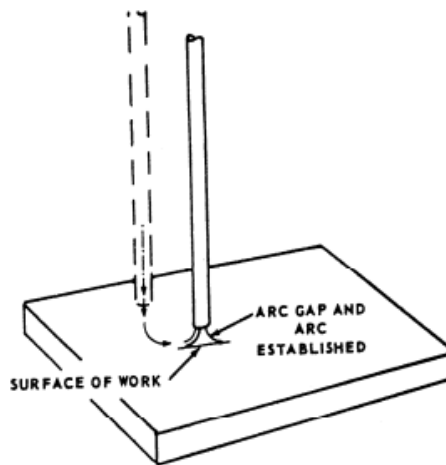

Figure 7-11.—Tapping method of starting the arc.

In the STRIKING or BRUSHING method, the electrode is brought down to the work with a lateral motion similar to striking a match. As soon as the electrode touches the work surface, it must be raised to establish the arc (fig. 7-10). The arc length or gap between the end of the electrode and the work should be equal to the diameter of the electrode. When the proper arc length is obtained, it produces a sharp, crackling sound.

In the TAPPING method, you hold the electrode in a vertical position to the surface of the work. The arc is started by tapping or bouncing it on the work surface and then raising it to a distance equal to the diameter of the electrode (fig. 7-11). When the proper length of arc is established, a sharp, crackling sound is heard.

When the electrode is withdrawn too slowly with either of the starting methods described above, it will stick or freeze to the plate or base metal. If this occurs, you can usually free the electrode by a quick sideways wrist motion to snap the end of the electrode from the plate. If this method fails, immediately release the electrode from the holder or shutoff the welding machine. Use a light blow with a chipping hammer or a chisel to free the electrode from the base metal.

CAUTION

NEVER remove your helmet or the shield from your eyes as long as there is any possibility that the electrode could produce an arc.

After you strike the arc, the end of the electrode melts and flows into the molten crater of the base metal. To compensate for this loss of metal, you must adjust the length of the arc. Unless you keep moving the electrode closer to the base metal, the length of the arc will increase. An arc that is too long will have a humming type of sound. One that is too short makes a popping noise. When the electrode is fed down to the plate and along the surface at a constant rate, a bead of metal is deposited or welded onto the surface of the base metal. After striking the arc, hold it for a short time at the starting point to ensure good fusion and crater deposition. Good arc welding depends upon the control of the motion of the electrode along the surface of the base metal.

Setting the Current

The amount of current used during a welding operation depends primarily upon the diameter of the electrode. As a rule, higher currents and larger diameter electrodes are better for welding in the flat position than the vertical or

overhead position. Manufacturers of electrodes usually specify a current range for each type and size of electrode; this information is normally found on the face of the electrode container.

Since most recommended current settings are only approximate, final current settings and adjustments need to be made during the welding operation. For example, when the recommended current range for an electrode is 90-100 amperes, the usual practice is to set the controls midway between the two limits, or at 95 amperes. After starting the weld, make your final adjustments by either increasing or decreasing the current.

When the current is too high, the electrode melts faster and the molten puddle will be excessively large and irregular. High current also leaves a groove in the base metal along both sides of the weld. This is called undercutting, and an example is shown in figure 7-12, view C

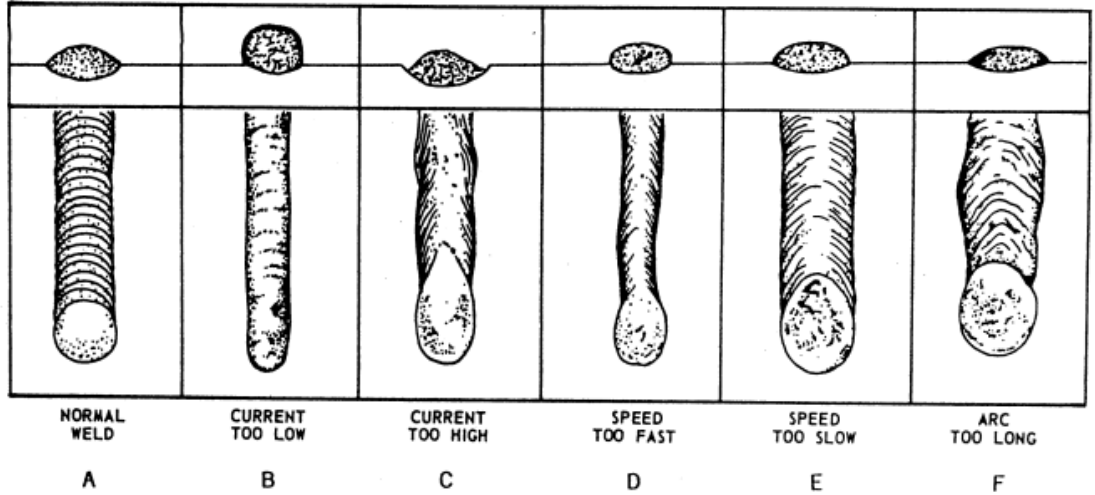

Figure 7-12.—Comparison chart of welds.

With current that is too low, there is not enough heat to melt the base metal and the molten pool will be too small. The result is poor fusion and a irregular shaped deposit that piles up, as shown in figure 7-12, view B. This piling up of molten metal is called overlap. The molten metal from the electrode lays on the work without penetrating the base metal. Both undercutting and overlapping result in poor welds, as shown in figure 7-13.

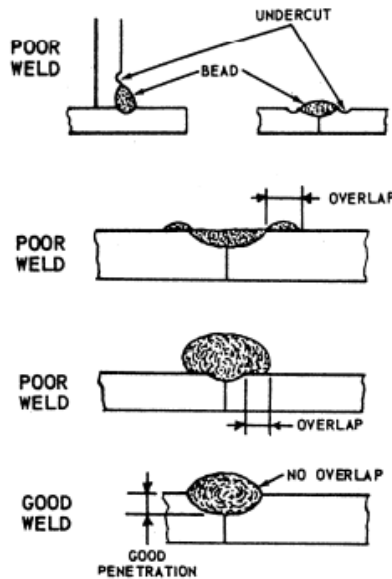

Figure 7-13.—Undercuts and overlaps in welding.

When the electrode, current, and polarity are correct, a good arc produces a sharp, crackling sound. When any of these conditions are incorrect, the arc produces a steady, hissing sound, such as steam escaping.

Length of Arc

When an arc is too long, the metal melts off the electrode in large globules and the arc may break frequently. This produces a wide, spattered, and irregular deposit with insufficient fusion between the base metal and the weld (fig. 7-12, view F).

When an arc is too short, it fails to generate enough heat to melt the base metal properly, causes the electrode to stick frequently to the base metal, and produces uneven deposits with irregular ripples. The recommended length of the arc is equal to the diameter of the bare end of the electrode, as shown in figure 7-14.

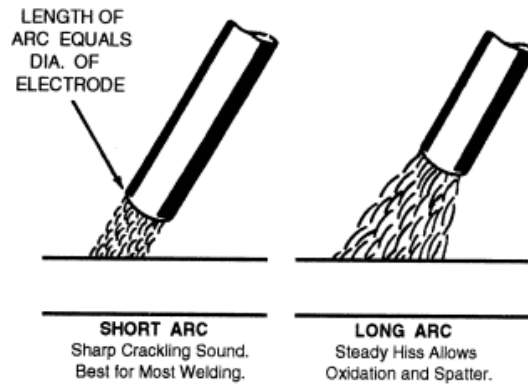

Figure 7-14.—Setting the length of an arc.

The length of the arc depends upon the type of electrode and the type of welding being done; therefore, for smaller diameter electrodes, a shorter arc is necessary than for larger electrodes. Remember: the length of the arc should be about equal to the diameter of the bare electrode except when welding in the vertical or over-head position. In either position, a shorter arc is desirable because it gives better control of the molten puddle and prevents atmospheric impurities from entering the weld.

Electrode Angle

The angle at which you hold the electrode greatly affects the shape of the weld bead which is very important in fillet and deep groove welding. The electrode angle consists of two positions: work angle and travel angle. Work angle is the angle from the horizontal measured at right angles to the direction of welding (fig. 7-15). Travel angle is the angle in the direction of welding and may vary from 5 to 30 degrees, depending on the welder's choice and conditions (fig. 7-16).

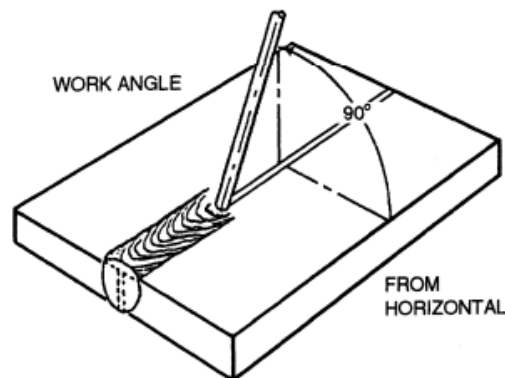

Figure 7-15.—Work angle.

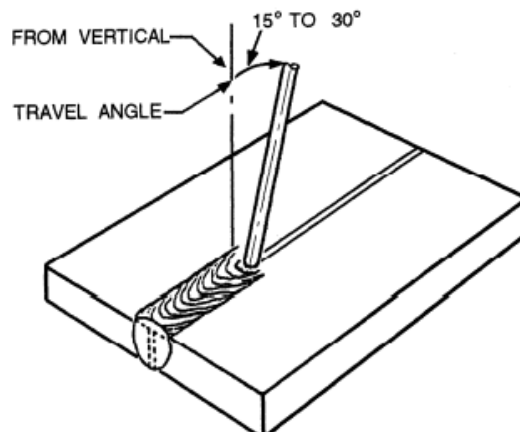

Figure 7-16.—Travel angle

Work angle is especially important in multiple-pass fillet welding. Normally, a small variance of the work angle will not affect the appearance or quality of a weld; however, when undercuts occur in the vertical section of a fillet weld, the angle of the arc should be lowered and the electrode directed more toward the vertical section.

Travel Speed

Travel speed is the rate at which the electrode travels along a weld seam. The maximum speed of welding depends on the skill of the operator, the position of the weld, the type of electrode, and the required joint

penetration.

Normally, when the travel speed is too fast, the molten pool cools too quickly, locking in impurities and causing the weld bead to be narrow with pointed ripples, as shown in figure 7-12, view D. On the other hand, if the travel speed is too slow, the metal deposit piles up excessively and the weld is high and wide, as shown in figure 7-12, view E. In most cases, the limiting factor is the highest speed that produces a satisfactory surface appearance of a normal weld, as shown in figure 7-12, view A.

Breaking the Arc

The most commonly used method to break the arc is to hold the electrode stationary until the crater is filled and then slowly withdraw the electrode. This method reduces the possibilities of crater cracks.

Reestablishing the Arc

When it becomes necessary to reestablish the arc (as in a long weld that requires the use of more than one electrode), the crater must first be cleaned before striking the arc. Strike the tip of the new electrode at the forward (cold) end of the crater and establish an arc. Move the arc backward over the crater, and then move forward again and continue the weld. This procedure fills the crater and prevents porosity and slag inclusions.

Peening

Peening is a procedure that involves lightly hammering a weld as it cools. This process aids in relieving built-up stresses and preventing surface cracking in the joint area; however, peening should be done with care because excess hammering can work harden and increase stresses in the weld. This condition leads to weld embrittlement and early failure. Some welds are covered by specific codes that prohibit peening so you should check the weld specification before peening.

Arc Welding Positions

The types of welds, joints, and welding positions used in manual-shielded metal arc welding are very similar to those used in oxygas welding. Naturally, the techniques are somewhat different because of the equipment involved is different.

Flat-Position Welding

Earlier we explained that welding can be done in any position, but it is much simpler when done in the flat position. In this position, the work is less tiring, welding speed is faster, the molten puddle is not as likely to run, and better penetration can be achieved. Whenever possible, try to position the work so you can weld in the flat position. In the flat position, the face of the weld is approximately horizontal.

Joint Type Butt joints are the primary type of joints used in the flat position of welding; however, flat-position welding can be made on just about any type of joint providing you can rotate the section you are welding on to the appropriate position. Techniques that are useful in making butt joints in the flat position, with and without the use of backing strips, are described below.

BUTT JOINTS WITHOUT BACKING STRIPS.— A butt joint is used to join two plates having surfaces in about the same plane. Several forms of butt joints are shown in figure 7-17.

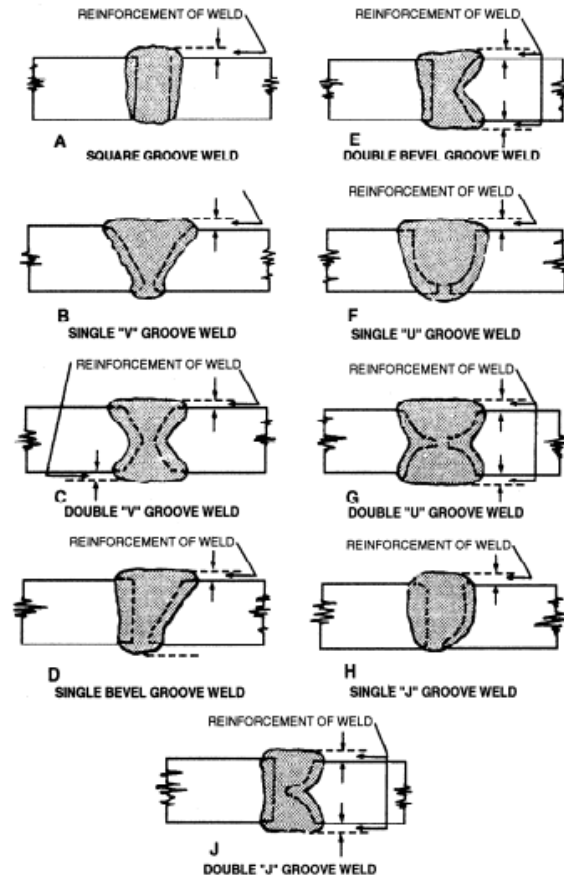

Figure 7-17.—Butt joints in the flat position.

Plates up to 1/8 inch thick can be welded in one pass with no special edge preparation. Plates from 1/8 to 3/16 inch in thickness also can be welded with no special edge preparation by welding on both sides of the joint.

Tack welds should be used to keep the plates aligned for welding. The electrode motion is the same as that used in making a bead weld.

In welding 1/4-inch plate or heavier, you should prepare the edges of the plates by beveling or by J-, U-, or V-grooving, whichever is the most applicable. You should use single or double bevels or grooves when the specifications and/or the plate thickness requires it. The first bead is deposited to seal the space between the two plates and to weld the root of the joint. This bead or layer of weld metal must be thoroughly cleaned to remove all slag and dirt before the second layer of metal is deposited.

In making multipass welds, as shown in figure 7-18, the second, third, and fourth layers of weld metal are made with a weaving motion of the electrode. Clean each layer of metal before laying additional beads. You may use one of the weaving motions shown in figure 7-19, depending upon the type of joint and size of electrode.

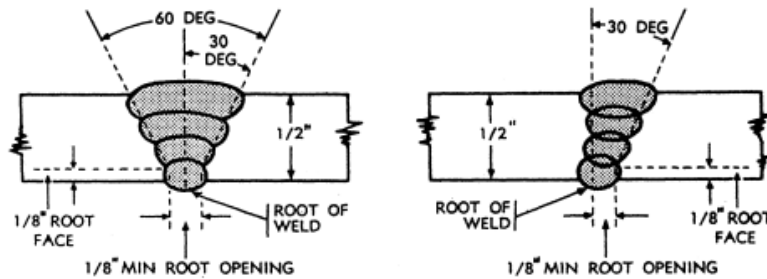

Figure 7-18.—Butt welds with multipass beads.

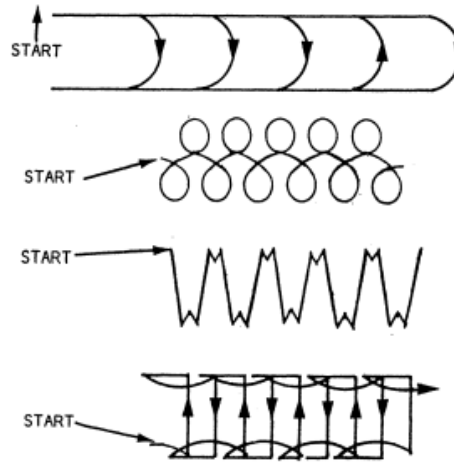

Figure 7-19.—Weave motions used in manual shielded arc welding.

In the weaving motion, oscillate or move the electrode uniformly from side to side, with a slight hesitation at the end of each oscillation. Incline the electrode 5 to 15 degrees in the direction of welding as in bead welding.

When the weaving motion is not done properly, undercutting could occur at the joint, as shown in figure 7-20. Excessive welding speed also can cause undercutting and poor fusion at the edges of the weld bead.

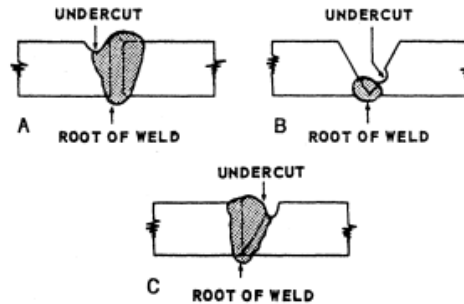

Figure 7-20.—Undercutting in butt joint welds.

BUTT JOINTS WITH BACKING STRIPS.— Welding 3/16-inch plate or thicker requires backing strips to ensure complete fusion in the weld root pass and to provide better control of the arc and the weld metal. Prepare the edges of the plates in the same manner as required for welding without backing strips.

For plates up to 3/8 inch thick, the backing strips should be approximately 1 inch wide and 3/16 inch thick. For plates more than 1/2 inch thick, the backing strips should be 1 1/2 inches wide and 1/4 inch thick. Tack-weld the backing strip to the base of the joint, as shown in figure 7-21. The backing strip acts as a cushion for the root pass. Complete the joint by welding additional layers of metal. After you complete the joint, the backing strip may be “washed” off or cut away with a cutting torch.

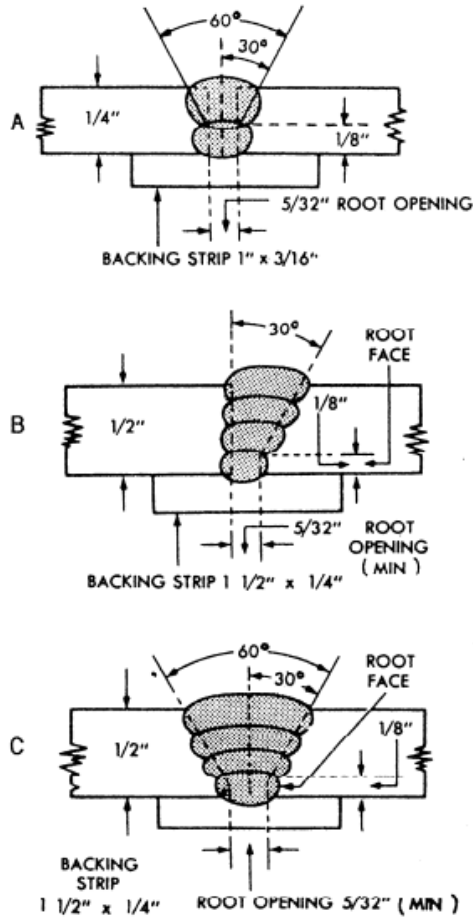

Figure 7-21.—Use of backing strips in welding butt joints.

When specified, place a seal bead along the root of the joint.

Bear in mind that many times it will not always be possible to use a backing strip; therefore, the welder must be able to run the root pass and get good penetration without the formation of icicles.

Horizontal-Position Welding

You will discover that it is impossible to weld all pieces in the flat position. Often the work must be done in the horizontal position. The horizontal position has two basic forms, depending upon whether it is used with a groove weld or a fillet weld. In a groove weld, the axis of the weld lies in a relative horizontal plane and the face of the weld is in a vertical plane (fig. 7-22). In a fillet weld, the welding is performed on the upper side of a relatively horizontal surface and against an approximately vertical plane (fig. 7-23).

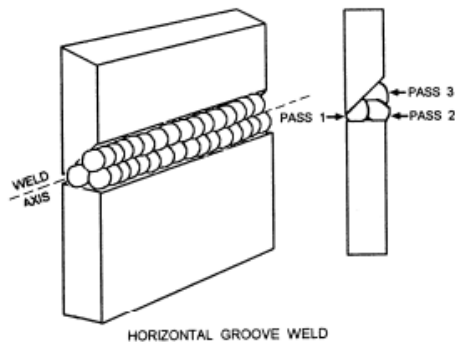

Figure 7-22.—Horizontal groove weld.

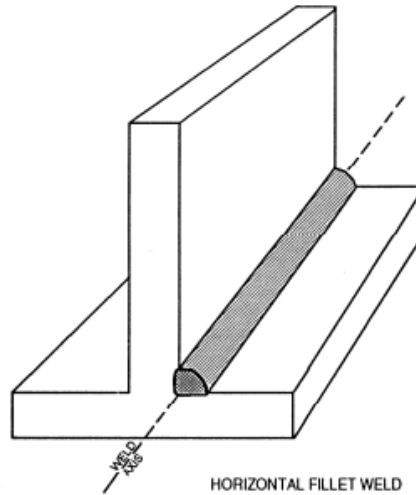

Figure 7-23.—Horizontal fillet weld,

An inexperienced welder usually finds the horizontal position of arc welding difficult, at least until he has developed a fair degree of skill in applying the proper technique. The primary difficulty is that in this position you have no "shoulder" of previously deposited weld metal to hold the molten metal.

Electrode Movement

In horizontal welding, position the electrode so that it points upward at a 5- to 10-degree angle in conjunction with a 20-degree travel angle (fig. 7-24). Use a narrow weaving motion in laying the bead. This weaving motion distributes the heat evenly, reducing the tendency of the molten puddle to sag. You should use the shortest arc length possible, and when the force of the arc under-cuts the plate at the top of the bead, lower the electrode holder a little to increase the upward angle.

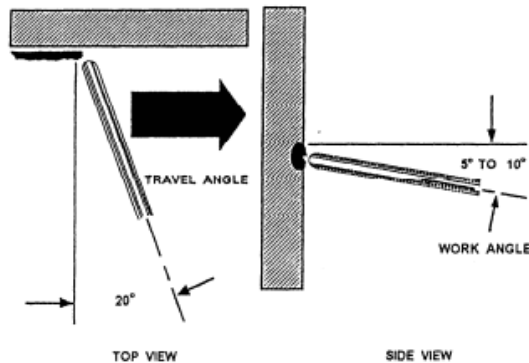

Figure 7-24.—Horizontal welding angles.

As you move in and out of the crater, pause slightly each time you return. This keeps the crater small and the bead has less tendency to sag.

Joint Type

Horizontal-position welding can be used on most types of joints. The most common types of joints it is used on are tee joints, lap joints, and butt joints.

TEE JOINTS.— When you make tee joints in the horizontal position, the two plates are at right angles to each other in the form of an inverted T. The edge of the vertical plate may be tack-welded to the surface of the horizontal plate, as shown in figure 7-25.

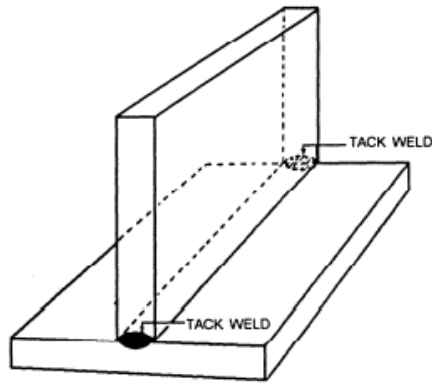

Figure 7-25.—Tack-weld to hold the tee joint elements in place.

A fillet weld is used in making the tee joint, and a short arc is necessary to provide good fusion at the root and along the legs of the weld (fig. 7-26, view A). Hold the electrode at an angle of 45 degrees to the two plate surfaces (fig. 7-26, view B) with an incline of approximately 15 degrees in the direction of welding.

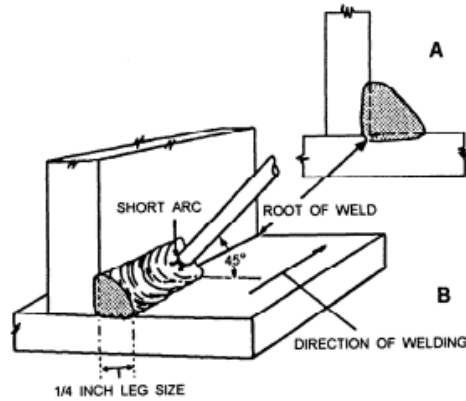

Figure 7-26.—Position of electrode and fusion area of fillet weld on a tee joint.

When practical, weld light plates with a fillet weld in one pass with little or no weaving of the electrode. Welding of heavier plates may require two or more passes in which the second pass or layer is made with a semicircular weaving motion, as shown in figure 7-27. To ensure good fusion and the prevention of undercutting, you should make a slight pause at the end of each weave or oscillation.

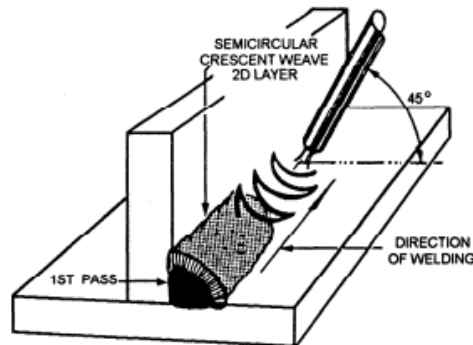

Figure 7-27.—Weave motion for multipass fillet weld.

For fillet-welded tee joints on 1/2-inch plate or heavier, deposit stringer beads in the sequence shown in figure 7-28.

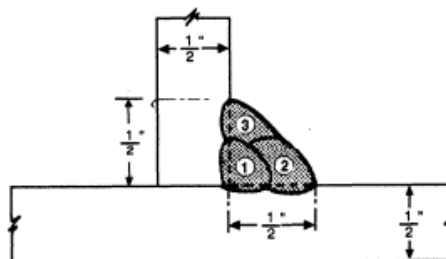

Figure 7-28.—Order of making stringer beads for a tee joint in heavy plate.

Chain-intermittent or staggered-intermittent fillet welds, as shown in figure 7-29, are used on long tee joints. Fillet welds of these types are for joints where high weld strength is not required; however, the short welds are arranged so the finished joint is equal in strength to that of a joint that has a fillet weld along the entire length of one side. Intermittent welds also have the advantage of reduced warpage and distortion.

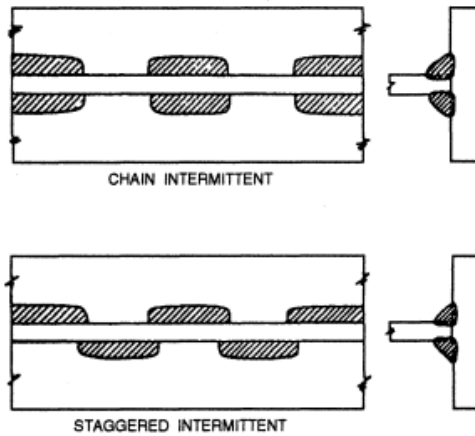

Figure 7-29.—Intermittent fillet welds.

LAP JOINTS.— When you make a lap joint, two overlapping plates are tack-welded in place (fig. 7-30), and a fillet weld is deposited along the joint.

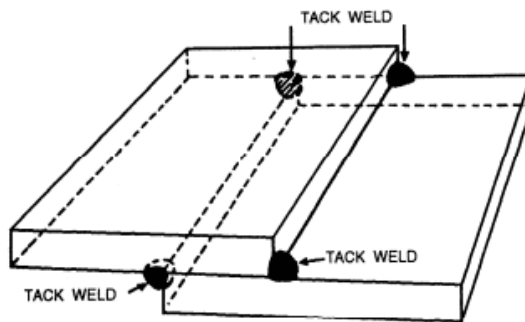

Figure 7-30.—Tack welding a lap joint.

The procedure for making this fillet weld is similar to that used for making fillet welds in tee joints. You should hold the electrode so it forms an angle of about 30 degrees from the vertical and is inclined 15 degrees in the direction of welding. The position of the electrode in relation to the plates is shown in figure 7-31. The weaving motion is the same as that used for tee joints, except that the pause at the edge of the top plate is long enough to ensure good fusion without undercut. Lap joints on 1/2-inch plate or heavier are made by depositing

a sequence of stringer beads, as shown in figure 7-31.

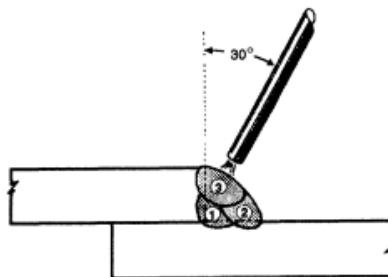

Figure 7-31.—Position of electrode on a lap joint.

In making lap joints on plates of different thickness, you should hold the electrode so that it forms an angle of between 20 and 30 degrees from the vertical (fig. 7-32). Be careful not to overheat or undercut the thinner plate edge.

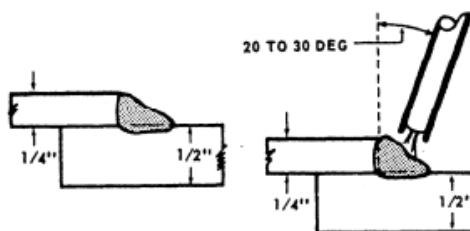

Figure 7-32.—Lap joints on plates of different thickness.

BUTT JOINTS.— Most butt joints, designed for horizontal welding, have the beveled plate positioned on the top. The plate that is not beveled is on the bottom and the flat edge of this plate provides a shelf for the molten metal so that it does not run out of the joint (fig. 7-33). Often both edges are beveled to form a 60-degree included angle. When this type of joint is used, more skill is required because you do not have the retaining shelf to hold

the molten puddle.

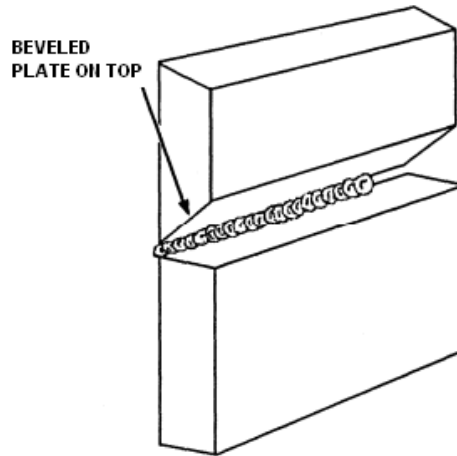

Figure 7-33.—Horizontal butt joint.

The number of passes required for a joint depends on the diameter of the electrode and the thickness of the metal. When multiple passes are required (fig. 7-34), place the first bead deep in the root of the joint. The electrode holder should be inclined about 5 degrees downward. Clean and remove all slag before applying each following bead. The second bead should be placed with the electrode holder held about 10 degrees upward. For the third pass, hold the electrode holder 10 to 15 degrees downward from the horizontal. Use a slight weaving motion and ensure that each bead penetrates the base metal.

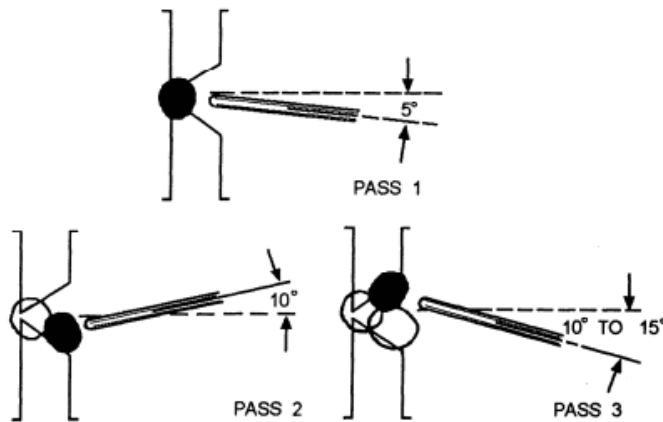

Figure 7-34.—Multiple passes.

Vertical-Position Welding

A "vertical weld" is defined as a weld that is applied to a vertical surface or one that is inclined 45 degrees or less (fig. 7-35). Erecting structures, such as buildings, pontoons, tanks, and pipelines, require welding in this position. Welding on a vertical surface is much more difficult than welding in the flat or horizontal position due to the force of gravity. Gravity pulls the molten metal down. To counteract this force, you should use fast-freeze or fill-freeze electrodes.

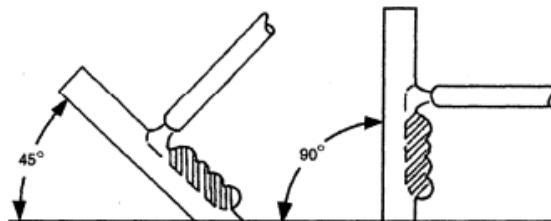

Figure 7-35.—Vertical weld plate positions.

Vertical welding is done in either an upward or downward position. The terms used for the direction of welding are vertical up or vertical down. Vertical down welding is suited for welding light gauge metal because the penetration is shallow and diminishes the possibility of burning through the metal. Furthermore, vertical down welding is faster which is very important in production work.

Current Settings and Electrode Movement

In vertical arc welding, the current settings should be less than those used for the same electrode in the flat

position. Another difference is that the current used for welding upward on a vertical plate is slightly higher than the current used for welding downward on the same plate.

To produce good welds, you must maintain the proper angle between the electrode and the base metal. In welding upward, you should hold the electrode at 90 degrees to the vertical, as shown in figure 7-36, view A. When weaving is necessary, oscillate the electrode, as shown in figure 7-36, view B.

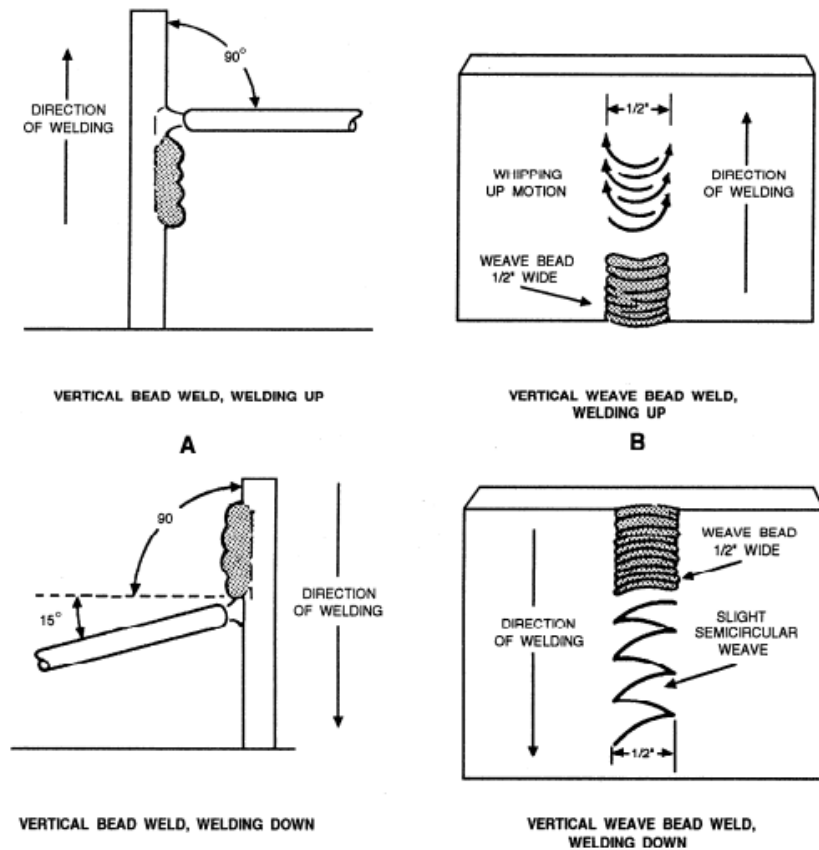

Figure 7-36.—Bead welding in the vertical position.

In vertical down welding, incline the outer end of the electrode downward about 15 degrees from the horizontal while keeping the arc pointing upward toward the deposited molten metal (figure 7-36, view C). When vertical down welding requires a weave bead, you should oscillate the electrode, as shown in figure 7-36, view D.

Joint Type

Vertical welding is used on most types of joints. The types of joints you will most often use it on are tee joints, lap joints, and butt joints.

When making fillet welds in either tee or lap joints in the vertical position, hold the electrode at 90 degrees to the plates or not more than 15 degrees off the horizontal for proper molten metal control. Keep the arc short to obtain good fusion and penetration.

TEE JOINTS.— To weld tee joints in the vertical position, start the joint at the bottom and weld upward. Move the electrode in a triangular weaving motion, as shown in figure 7-37, view A. A slight pause in the weave, at the points indicated, improves the sidewall penetration and provides good fusion at the root of the joint.

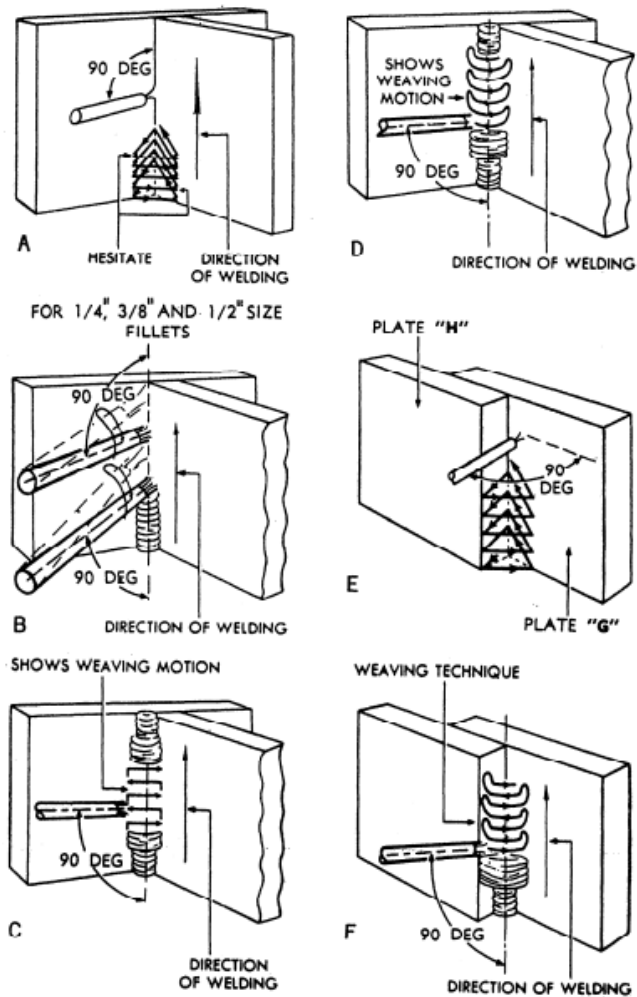

Figure 7-37.—Fillet welds in the vertical position.

When the weld metal overheats, you should quickly shift the electrode away from the crater without breaking the arc, as shown in figure 7-37, view B. This permits the molten metal to solidify without running downward. Return the electrode immediately to the crater of the weld in order to maintain the desired size of the weld.

When more than one pass is necessary to make a tee weld, you may use either of the weaving motions shown in figure 7-37, views C and D. A slight pause at the end of the weave will ensure fusion without undercutting the edges of the plates.

LAP JOINTS.— To make welds on lap joints in the vertical position, you should move the electrode in a triangular weaving motion, as shown in figure 7-37, view E. Use the same procedure, as outlined above for the tee joint, except direct the electrode more toward the vertical plate marked "G." Hold the arc short, and pause slightly at the surface of plate G. Try not to undercut either of the plates or to allow the molten metal to overlap at the edges of the weave.

Lap joints on heavier plate may require more than one bead. If it does, clean the initial bead thoroughly and place all subsequent beads as shown in figure 7-37, view F. The precautions to ensure good fusion and uniform weld deposits that was previously outlined for tee joints also apply to lap joints.

BUTT JOINTS.— Prepare the plates used in vertical welding identically to those prepared for welding in the flat position. To obtain good fusion and penetration with no undercutting, you should hold a short arc and the motion of the arc should be carefully controlled.

Butt joints on beveled plates 1/4 inch thick can be welded in one pass by using a triangular weave motion, as shown in figure 7-38, view A.

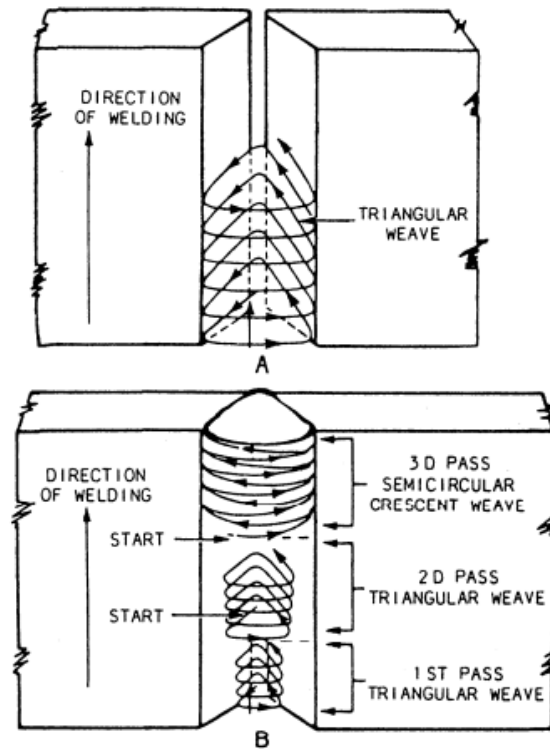

Figure 7-38.—Butt joint welding in the vertical position.

Welds made on 1/2-inch plate or heavier should be done in several passes, as shown in figure 7-38, view B. Deposit the last pass with a semicircular weaving motion with a slight “whip-up” and pause of the electrode at the edge of the bead. This produces a good cover pass with no undercutting. Welds made on plates with a backup strip should be done in the same manner.

E-7018 Electrode Welding Technique

The previously described vertical welding techniques generally cover all types of electrodes; however, you should modify the procedure slightly when using E-7018 electrodes.

When vertical down welding, you should drag the electrode lightly using a very short arc. Refrain from using a long arc since the weld depends on the molten slag for shielding. Small weaves and stringer beads are preferred to wide weave passes. Use higher amperage with ac than with dc. Point the electrode straight into the joint and tip it forward only a few degrees in the direction of travel.

On vertical up welding, a triangular weave motion produces the best results. Do not use a whipping motion or remove the electrode from the molten puddle. Point the electrode straight into the joint and slightly upward in order to allow the arc force to help control the puddle.

Adjust the amperage in the lower level of the recommended range.

Overhead-Position Welding

Overhead welding is the most difficult position in welding. Not only do you have to contend with the force of gravity but the majority of the time you also have to assume an awkward stance. Nevertheless, with practice it is possible to make welds equal to those made in the other positions.

Current Settings and Electrode Movement

To retain complete control of the molten puddle, use a very short arc and reduce the amperage as recommended. As in the vertical position of welding, gravity causes the molten metal to drop or sag from the plate. When too long an arc is held, the transfer of metal from the electrode to the base metal becomes increasingly difficult, and the chances of large globules of molten metal dropping from the electrode increase. When you routinely shorten and lengthen the arc, the dropping of molten metal can be prevented; however, you will defeat your purpose should you carry too large a pool of molten metal in the weld.

One of the problems encountered in overhead welding is the weight of the cable. To reduce arm and wrist fatigue, drape the cable over your shoulder when welding

in the standing position. When sitting, place the cable over your knee. With experience, cable placement will become second nature.

WARNING

Because of the possibility of falling molten metal, use a protective garment that

has a tight fitting collar that buttons or zips up to the neck. Roll down your sleeves and wear a cap and appropriate shoes

Type of Welds

Techniques used in making bead welds, butt joints, and fillet welds in the overhead position are discussed in the following paragraphs.

BEAD WELDS.— For bead welds, the work angle of the electrode is 90 degrees to the base metal (fig. 7-39, view A). The travel angle should be 10 to 15 degrees in the direction of welding (fig. 7-39, view B).

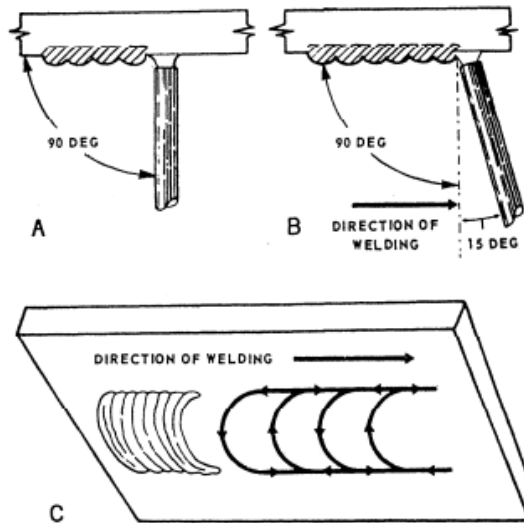

Figure 7-39.—Position of electrode and weave motion in the overhead position.

Weave beads can be made by using the motion shown in figure 7-39, view C. A rather rapid motion is necessary at the end of each semicircular weave to control the molten metal deposit. Avoid excessive weaving because this can cause overheating of the weld deposit and the formation of a large, uncontrollable pool.

BUTT JOINTS.— Prepare the plates for overhead butt welding in the same manner as required for the flat position. The best results are obtained when backing strips are used; however, you must remember that you will not always be able to use a backing strip. When you bevel the plates with a featheredge and do not use a backing strip, the weld will repeatedly burn through unless extreme care is taken by the operator.

For overhead butt welding, bead welds are preferred over weave welds. Clean each bead and chip out the rough areas before placing the next pass. The electrode position and the order of deposition of the weld beads when welding on 1/4- or 1/2-inch plate are shown in figure 7-40, views B and C. Make the first pass with the electrode held at 90 degrees to the plate, as shown in figure 7-40, view A. When you use an electrode that is too large, you can not hold a short arc in the root area. This results in insufficient root penetration and inferior joints.

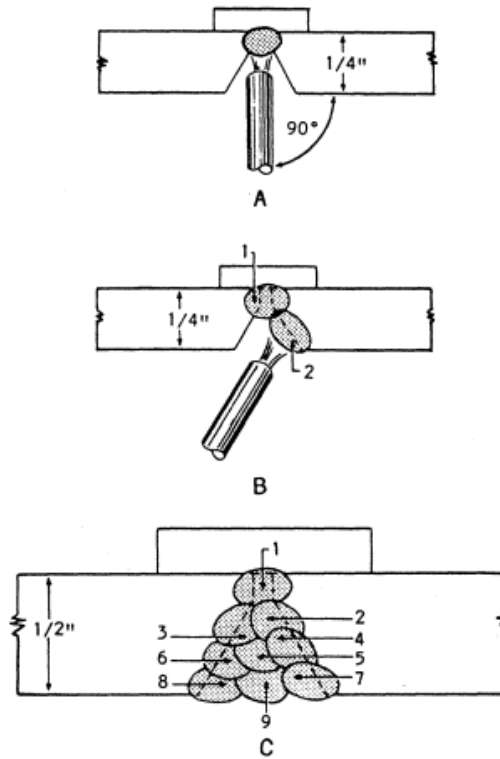

Figure 7-40.—Multipass butt joint in the overhead position.

FILLET WELDS.— In making fillet welds in either tee or lap joints in the overhead position, maintain a short arc and refrain from weaving of the electrode. Hold the electrode at approximately 30 degrees to the vertical plate and move it uniformly in the direction of welding, as shown in figure 7-41, view B. Control the arc motion to secure good penetration in the root of the weld and good fusion with the sidewalls of the vertical and horizontal plates. When the molten metal becomes too fluid and tends to sag, whip the electrode quickly away from the crater and ahead of the weld to lengthen the arc and allow the metal to solidify. Immediately return the electrode to the crater and continue welding.

Overhead fillet welds for either tee or lap joints on heavy plate require several passes or beads to complete the joint. One example of an order of bead deposition is shown in figure 7-41, view A. The root pass is a string bead made with no weaving motion of the electrode. Tilt the electrode about 15 degrees in the direction of welding, as shown in figure 7-41, view C, and with a slight circular motion make the second, third, and fourth passes. This motion of the electrode permits greater control and better distribution of the weld metal. Remove all slag and oxides from the surface of each pass by chipping or wire brushing before applying additional beads to the joint.

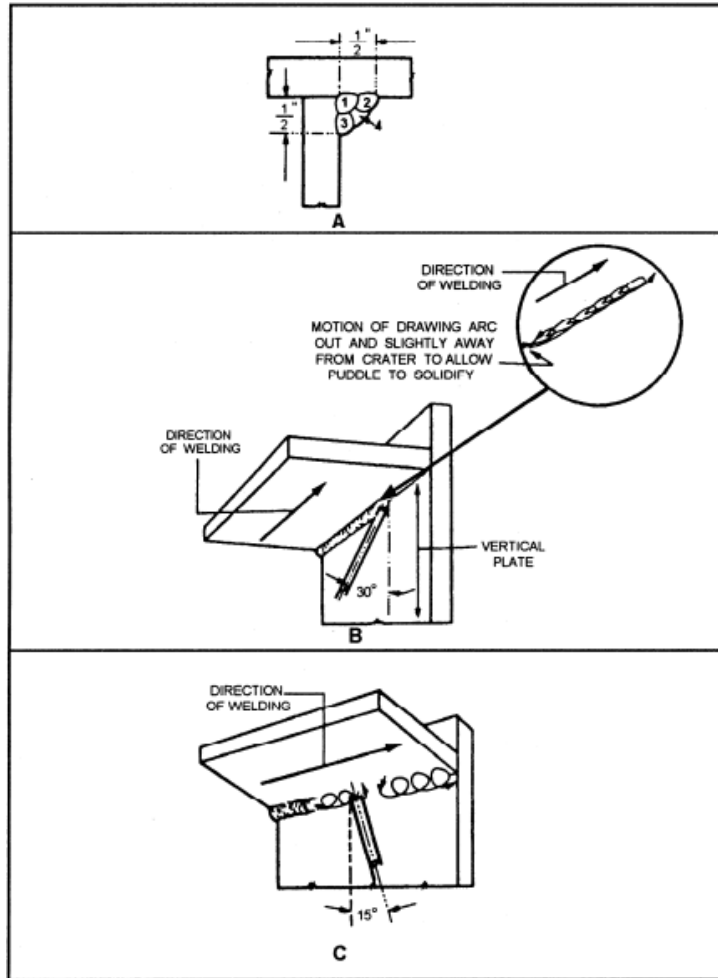







Figure 7-41.—Fillet welding in the overhead position.

Welding Difficulties

Many of the welding difficulties in metal-arc welding are the same as in oxygas welding. A few such problems include undercut, cracked welds, poor fusion, and incomplete penetration.

Table 7-3 provides an illustration of the most common welding problems encountered during the arc-welding process and methods to correct them.

Table 7-3—Causes and Cures of Common Welding Problems

<p>porous welds</p> <p>WHY</p> <ol style="list-style-type: none"> 1. Short arc with exception of low hydrogen and stainless 2. Insufficient puddling time 3. Impaired base metal 4. Poor electrode 5. Improper shield coverage <p>WHAT TO DO</p> <ol style="list-style-type: none"> 1. Check impurities in base metal 2. Allow sufficient puddling time for gases to escape 3. Use proper current 	 <ol style="list-style-type: none"> 4. Weave your weld to eliminate pin holes 5. Use proper electrode for job 6. Hold longer arc 7. Check shield gas 	<p>cracked welds</p> <p>WHY</p> <ol style="list-style-type: none"> 1. Wrong electrode 2. Weld and parts sizes unbalanced 3. Faulty welds 4. Faulty preparation 5. Rigid joint <p>WHAT TO DO</p> <ol style="list-style-type: none"> 1. Design structure to eliminate rigid joints 2. Heat parts before welding 3. Avoid welds in string beads 4. Keep ends free to move as long as possible 	 <ol style="list-style-type: none"> 5. Make sound welds of good fusion 6. Adjust weld size to parts size 7. Allow joints a proper and uniform gap 8. Work with amperage as low as possible
<p>poor penetration</p> <p>WHY</p> <ol style="list-style-type: none"> 1. Speed too fast 2. Electrode too large 3. Current too low 4. Faulty preparation <p>WHAT TO DO</p> <ol style="list-style-type: none"> 1. Use enough current to obtain desired penetration—weld slowly 	 <ol style="list-style-type: none"> 2. Select electrode according to welding groove size 3. Leave proper gap at bottom of weld 	<p>poor appearance</p> <p>WHY</p> <ol style="list-style-type: none"> 1. Faulty electrode 2. Overhang 3. Improper use of electrode 4. Wrong arc voltage and current <p>WHAT TO DO</p> <ol style="list-style-type: none"> 1. Use a proper welding technique 2. Avoid overheating 	 <ol style="list-style-type: none"> 3. Use a uniform weave 4. Avoid overly high current
<p>warping</p> <p>WHY</p> <ol style="list-style-type: none"> 1. Shrinkage of weld metal 2. Faulty clamping of parts 3. Faulty preparation 4. Overheating at joint <p>WHAT TO DO</p> <ol style="list-style-type: none"> 1. Peen joint edges before welding 2. Weld more rapidly 3. Avoid excessive space between parts 4. Preform parts before welding 	 <ol style="list-style-type: none"> 5. Use proper sequence 6. Clamp or tack parts properly—back-up to cool 7. Adopt a proper welding procedure 8. Use high speed, moderate penetration process 	<p>poor fusion</p> <p>WHY</p> <ol style="list-style-type: none"> 1. Wrong speed 2. Current improperly adjusted 3. Faulty preparation 4. Improper electrode size <p>WHAT TO DO</p> <ol style="list-style-type: none"> 1. Adjust electrode to match joint 2. Weave must be sufficient to melt sides of joint 	 <ol style="list-style-type: none"> 3. Select proper current and voltage 4. Keep weld metal from flowing away from plates
<p>undercutting</p> <p>WHY</p> <ol style="list-style-type: none"> 1. Faulty electrode or gun manipulation 2. Faulty electrode usage 3. Current too high <p>WHAT TO DO</p> <ol style="list-style-type: none"> 1. Use a uniform weave in butt welding 2. Avoid using an overly large electrode 3. Avoid excessive weaving 	 <ol style="list-style-type: none"> 4. Use moderate current, weld slowly 5. Hold electrode at safe distance from vertical plane in making horizontal fillet weld 	<p>brittle welds</p> <p>WHY</p> <ol style="list-style-type: none"> 1. Wrong electrode 2. Faulty preheating 3. Metal hardened by air <p>WHAT TO DO</p> <ol style="list-style-type: none"> 1. Preheat at 300° to 500° F. if welding on medium carbon steel or certain alloy steels 2. Make multiple layer welds 	 <ol style="list-style-type: none"> 3. Stress relieving after welding 4. Use low hydrogen processes for increased weld ductility
<p>splatter</p> <p>WHY</p> <ol style="list-style-type: none"> 1. Arc blow 2. Current too high 3. Arc too long 4. Faulty electrodes <p>WHAT TO DO</p> <ol style="list-style-type: none"> 1. Clean parts in weld area 2. Adjust current properly 	 <ol style="list-style-type: none"> 3. Adjust voltage 4. Pick suitable electrode 	<p>magnetic blow</p> <p>WHY</p> <ol style="list-style-type: none"> 1. Magnetic fields cause the arc to deviate from its intended course <p>WHAT TO DO</p> <ol style="list-style-type: none"> 1. Use steel blocks to alter magnetic path around arc 2. Divide the ground into parts 3. Weld in same direction the arc blows 	 <ol style="list-style-type: none"> 4. Use a short arc length 5. Locate the ground properly on the work 6. Use A C welding

Every welder has the responsibility of making each weld the best one possible. You can produce quality welds by adhering to the rules that follow.

- Use only high-quality welding machines, electrodes, and welding accessories.
- Know the base material that you are working on.
- Select the proper welding process that gives the highest quality welds for the base material used.
- Select the proper welding procedure that meets the service requirement of the finished weldment.
- Select the correct electrode for the job in question.
- When preheating is specified or required make sure you meet the temperature requirements. In any case, do not weld on material that is below 32°F without first preheating.
- Clean the base metal of all slag, paint, grease, oil, moisture, or any other foreign materials.
- Remove weld slag and thoroughly clean each bead before making the next bead or pass.
- Do not weld over cracks or porous tack welds. Remove defective tack welds before welding.
- Be particularly alert to obtain root fusion on the first pass of fillet and groove welds.
- When groove weld root gaps are excessive, build up one side of the joint before welding the pieces together.
- When fillet weld root gaps are excessive, be sure you increase the size of the fillet weld to the size of the root gap to maintain the strength requirement. In some cases, it is advantageous to make a groove weld I to avoid extremely large fillet welds.
- Inspect your work after completion and immediately remove and replace any defective weld.
- Observe the size requirement for each weld and make sure that you meet or slightly exceed the specified size.
- Make sure that the finished appearance of the weld is smooth and that overlaps and undercuts have been repaired.

Pipe Welding

Welding is the simplest and easiest way to join sections of pipe. The need for complicated joint designs and special threading equipment is eliminated. Welded pipe has reduced flow restrictions compared to mechanical connections and the overall installation costs are less. The most popular method for welding pipe is the shielded metal-arc process; however, gas shielded arc methods have made big inroads as a result of new advances in welding technology.

Pipe welding has become recognized as a profession in itself. Even though many of the skills are comparable to other types of welding, pipe welders develop skills that are unique only to pipe welding. Because of the hazardous materials that most pipelines carry, pipe welders are required to pass specific tests before they can be certified.

In the following paragraphs, pipe welding positions, pipe welding procedures, definitions, and related information are discussed.

PIPE WELDING POSITIONS

You may recall from an earlier lesson that there are four positions used in pipe welding. They are known as the

1. horizontal rolled position (1G)
2. horizontal fixed position (5G)
3. pipe inclined fixed (6G)
4. vertical position (2G).

Remember: these terms refer to the position of the pipe and not to the weld

PIPE WELDING PROCEDURES

Welds that you cannot make in a single pass should be made in interlocked multiple layers, not less than one layer for each 1/8 inch of pipe thickness. Deposit each layer with a weaving or oscillating motion. To prevent entrapping slag in the weld metal, you should clean each layer thoroughly before depositing the next layer.

Butt joints are commonly used between pipes and between pipes and welded fittings. They are also used for butt welding of flanges and welding stubs. In making a butt joint, place two pieces of pipe end to end, align them, and then weld them. (See fig. 7-42.) When the wall thickness of the pipe is 3/4 inch or less, you can use either the single V or single U type of butt joint; however, when the wall thickness is more than 3/4 inch, only the single U type should be used.

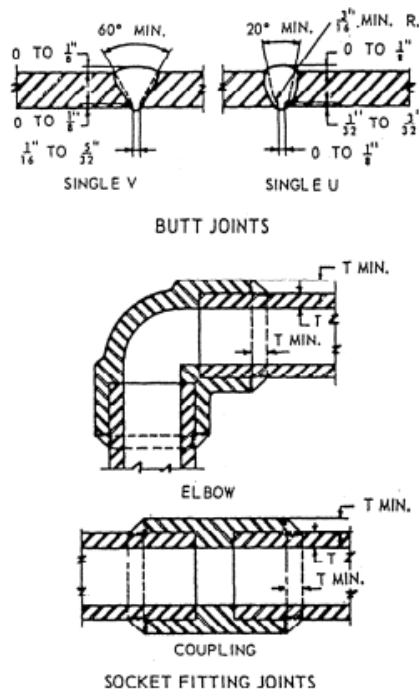

Figure 7-42.—Butt joints and socket fitting joints.

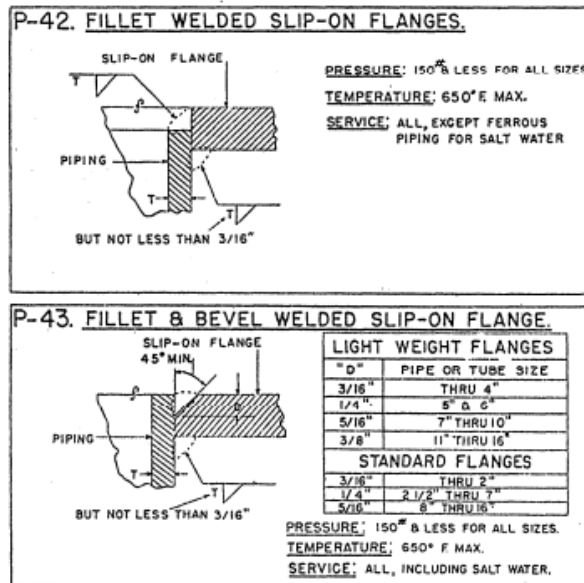

Figure 7-43.—Flange connections.

Fillet welds are used for welding slip-on and threaded flanges to pipe. Depending on the flange and type of service, fillet welds may be required on both sides of the flange or in combination with a bevel weld (fig. 7-43). Fillet welds are also used in welding screw or socket couplings to pipe, using a single fillet weld (fig. 7-42). Sometimes flanges require alignment. Figure 7-44 shows one type of flange square and its use in vertical and horizontal alignment.

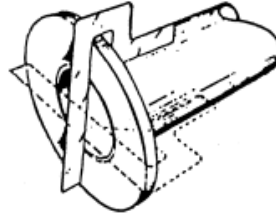

Figure 7-44.—Flange alignment.

Another form of fillet weld used in pipe fitting is a seal weld. A seal weld is used primarily to obtain tightness and prevent leakage. Seal welds should not be considered as adding strength to the joint.

JOINT PREPARATION AND FIT-UP

You must carefully prepare pipe joints for welding if you want good results. Clean the weld edges or surfaces of all loose scale, slag, rust, paint, oil, and other foreign matter. Ensure that the joint surfaces are smooth and uniform. Remove the slag from flame-cut edges; however, it is not necessary to remove the temper color.

When you prepare joints for welding, remember that bevels must be cut accurately. Bevels can be made by machining, grinding, or using a gas cutting torch. In fieldwork, the welding operator usually must make the bevel cuts with a gas torch. When you are beveling, cut away as little metal as possible to allow for complete fusion and penetration. Proper beveling reduces the amount of filler metal required which, in turn, reduces time and expense. In addition, it also means less strain in the weld and a better job of design and welding.

Align the piping before welding and maintain it in alignment during the welding operation. The maximum alignment tolerance is 20 percent of the pipe thickness. To ensure proper initial alignment, you should use clamps or jigs as holding devices. A piece of angle iron makes a good jig for a small-diameter pipe (fig. 7-45), while a section of channel or I-beam is more suitable for larger diameter pipe.

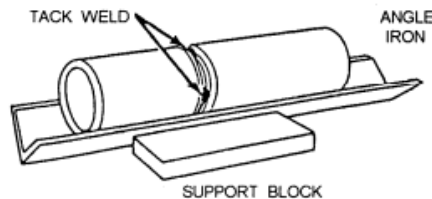

Figure 7-45.—Angle iron jig.

TACK WELDING

When welding material solidly, you may use tack welds to hold it in place temporarily. Tack welding is one of the most important steps in pipe welding or any other type of welding. The number of tack welds required depends upon the diameter of the pipe. For ½-inch pipe, you need two tacks; place them directly opposite each other. As a rule, four tacks are adequate for standard size of pipe. The size of a tack weld is determined by the wall thickness of the pipe. Be sure that a tack weld is not more than twice the pipe thickness in length or two thirds of the pipe thickness in depth. Tack welds should be the same quality as the final weld. Ensure that the tack welds have good fusion and are thoroughly cleaned before proceeding with the weld.

SPACERS

In addition to tack welds, spacers sometimes are required to maintain proper joint alignment. Spacers are accurately machined pieces of metal that conform to the dimensions of the joint design used. Spacers are sometimes referred to as chill rings or backing rings, and they serve a number of purposes. They provide a means for maintaining the specified root opening, provide a convenient location for tack welds, and aid in the pipe alignment. In addition, spacers can prevent weld spatter and the formation of slag or icicles inside the pipe.

ELECTRODE SELECTION

Select the electrode that is best suited for the position and type of welding to be done. For the root pass of a multilayer weld, you need an electrode large enough, yet not exceeding 3/16 inch, that ensures complete fusion and penetration without undercutting and slag inclusions.

Make certain the welding current is within the range recommended by the manufacturers of the welding machines

and electrodes.

WEATHER CONDITIONS

Do not assign a welder to a job under any of the following conditions listed below unless the welder and the work area are properly protected:

- When the atmospheric temperature is less than 0°F
- When the surfaces are wet
- When rain or snow is falling, or moisture is condensing on the weld surfaces
- During periods of high wind

At temperatures between 0°F and 32°F, heat the weld area within 3 inches of the joint with a torch to a temperature warm to the hand before beginning to weld.

Wearfacing

Welders can greatly extend the life of construction equipment by the use of wearfacing procedures. Wearfacing is the process of applying a layer of special composition metal onto the surface of another type of metal for the purpose of reducing wear. The selection of a wearfacing alloy for application is based on the ability of the alloy to withstand impact or abrasion. Impact refers to a blow or series of blows to a surface that results in fracture or gradual deterioration. Abrasion is the grinding action that results when one surface slides, rolls, or rubs against another. Under high-compressive loads, this action can result in gouging.

Alloys that are abrasion resistant are poor in with-standing impact. Conversely, those that withstand impact well are poor in resisting abrasion; however, there are many alloys whose wearfacing properties fall between the two extremes. These alloys offer some protection against abrasion and withstand impact well.

WORKPIECE PREPARATION

Before you wear-face a workpiece, all dirt, oil, rust, grease, and other foreign matter must be removed. If you do not, your finished product will be porous and subject to spalling. You also need a solid foundation; therefore, repair all cracks and remove any metal that is fatigued or rolled over.

PREHEATING

Depending on the type of metal, sometimes it is necessary to preheat the base metal to lessen distortion, to prevent spalling or cracking, and to avoid thermal shock. The preheating temperature depends on the carbon and alloy content of the base metal. In general, as carbon content increases so does the preheating temperature. Improper heating can adversely affect a metal by reducing its resistance to wear, by making it hard and brittle, or by making it more prone to oxidation and scaling.

To preheat properly, you must know the composition of the base metal. A magnet can be used to determine if you are working with carbon steel or austenitic manganese steel. Carbon steel is magnetic, but be careful because work-hardened austenitic manganese steel is also magnetic. Make sure that you check for magnetism in a non-worked part of the austenitic manganese steel. There are other ways to tell the difference between metals, such as cast iron and cast steel. Cast iron chips or cracks, while cast steel shaves. Also, some metals give off telltale sparks when struck by a chisel.

In preheating, you should raise the surface temperature of the workpiece to the desired point and then soak it until the heat reaches its core. After wearfacing, cool the work places slowly.

TECHNIQUES

Where possible, position the workpiece for down-hand welding. This allows you to finish the job quicker and at less cost.

The building up and wearfacing of cast iron is not generally recommended because cast iron tends to crack. However, some cast-iron parts that are subject to straight abrasion can be wearfaced successfully. You must preheat these parts to temperatures of 1000°F to 1200°F and then allow them to cool slowly after wearfacing. Peening deposits on cast iron helps to relieve stresses after welding.

Welding materials for building up worn parts differ from those used in wearfacing the same parts. Before wearfacing a badly worn part, you must first build it up to 3/16 to 3/8 of an inch of its finished size. The buildup material must be compatible with both the base metal and the wearfacing overlay as well as being strong enough to meet the structural requirements. Also, they must have the properties that enable them to resist cold flowing, mashing under high-compressive loads, and plastic deformation under heavy impact. Without these properties, the buildup materials cannot support the wearfacing overlay. When the overlay is not properly supported, it will span.

Many times high-alloy wearfacing materials are deposited on the parts before they are placed in service. The maximum allowable wear is usually no more than two layers deep (1/4 inch) before wearfacing. Try to deposit the wearfacing alloy in layers that are not too thick. Thick layers creates more problems than no over-layer at all. Usually you only need two layers. The first layer produces an admixture with the base metal; the second forms a wear-resistant surface.

In wearfacing built-up carbon-steel parts, maintain high interpass temperatures and use a weaving bead, rather than a stringer bead. (See fig. 7-46.) Limit the thickness of a single pass bead to 3/16 inch. Use the same technique for each layer and avoid severe quenching.

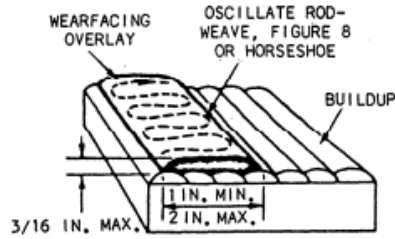

Figure 7-46.—Wearfacing techniques.

Deposits made with high-alloy electrodes should check on the surface. Checking reduces residual (locked-in) stresses. Without checking, the combination of residual stresses and service stresses may exceed tensile strength and cause deep cracks or spalling (fig. 7-47).

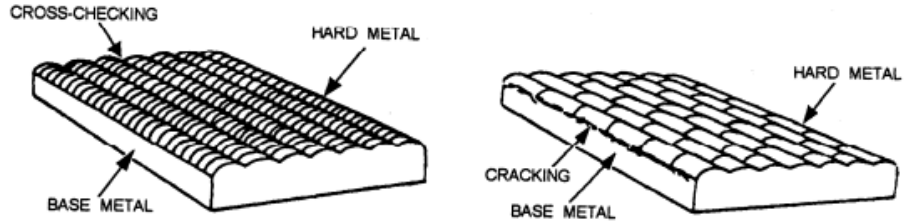

Figure 7-47.—Comparison between cross-checking and cracking.

Be sure to induce checking if it does not occur naturally or if it is unlikely to occur, as in large parts where heat builds up. You can bring on checking by sponging the deposit with a wet cloth or by spraying it with a fine mist of water. Also you can speed up checking

by occasionally striking it with a hammer while it is cooling. When a check-free deposit is required, use a softer alloy and adjust preheating and post-heating requirements.

Bulldozer Blades

Bulldozer blades are wear-faced by placing the end bits in the flat position and welding beads across the outer corners and along the edges. Be sure to preheat the high-carbon blades before wearfacing. On worn end bits, weld new corners and then wear-face (fig. 7-48).



Figure 7-48.—Wearfacing bulldozer end bits.

Shovel Teeth

Wear-face shovel teeth when they are new and before being placed into service. The weld bead pattern used in wearfacing can have a marked effect on the service life of the teeth. Wear-face shovel teeth that work mainly in rock with beads running the length of each tooth (fig. 7-49). This allows the rock to ride on the hard metal beads. Teeth that are primarily used to work in dirt, clay, or sand should be wear-faced with beads running across the width of each tooth, perpendicular to the direction of the material that flows past the teeth. (See fig. 7-49.)

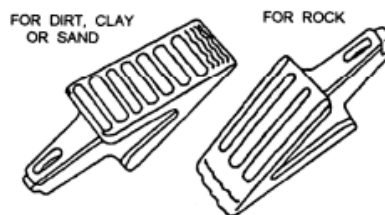

Figure 7-49.—Wearfacing shovel teeth.

This allows the material to fill the spaces between the beads and provide more protection to the base metal. Another effective pattern is the waffle or crosshatch (fig. 7-50). The wearfacing is laid on the top and sides of each tooth, 2 inches from its point. Stringer beads behind a solid deposit reduce wash (fig. 7-51).

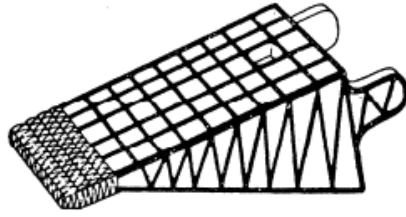

Figure 7-50.—Waffle or crosshatching.

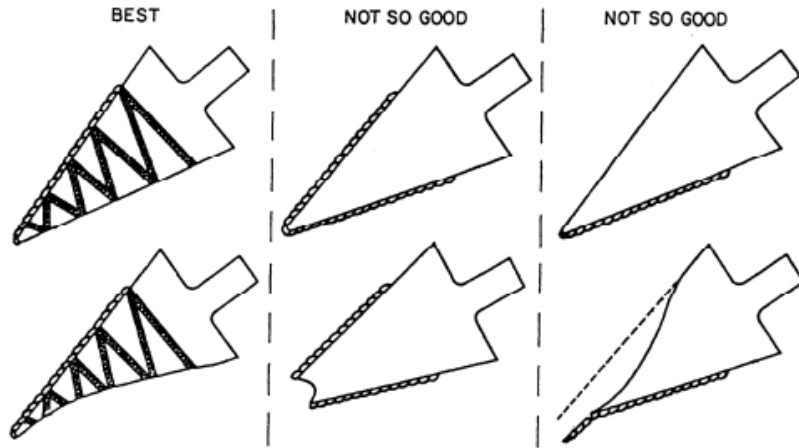

Figure 7-51.—Comparison of wearfacing patterns for shovel teeth.

Carbon-Arc Cutting

Metals can be cut cleanly with a carbon electrode arc because no foreign metals are introduced at the arc. The cutting current should be 25 to 50 amps above the welding current for the same thickness of metal.

The carbon electrode point should be ground so that it is very sharp. During the actual cutting, move the carbon electrode in a vertical elliptical movement to undercut the metal; this aids in the removal of the molten metal. As in oxygen cutting, a crescent motion is preferred. Figure 7-52 shows the relative positions of the electrode and the work in the cutting of cast iron.

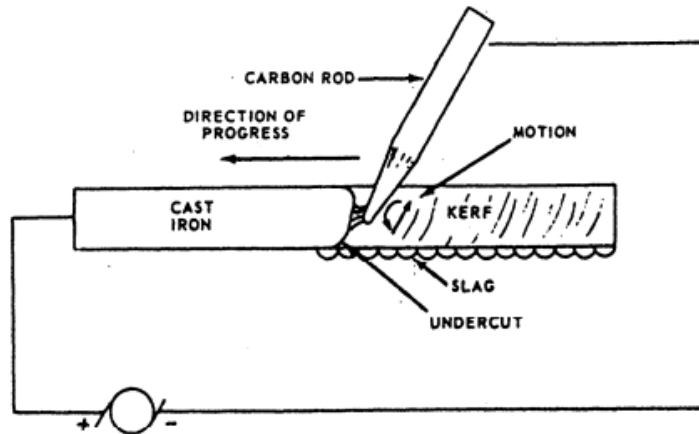

Figure 7-52.—Carbon-arc cutting on cast iron.

The carbon-arc method of cutting is successful on cast iron because the arc temperature is high enough to melt the oxides formed. It is especially important to undercut the cast-iron kerf to produce an even cut. Position the electrode so the molten metal flows away from the gouge or cutting areas. Table 7-4 is a list of cutting speeds, plate thicknesses, and current settings for carbon-arc cutting.

Table 7-4.—Table of Recommended Electrode Sizes, Current Settings, and Cutting Speeds for Carbon-Arc Cutting Different Thicknesses

THICKNESS OF PLATE INCHES	CURRENT SETTING AND CARBON DIA.			
	300 AMPS. 1/2 IN. DIA.	500 AMPS. 5/8 IN. DIA.	700 AMPS. 3/4 IN. DIA.	1000 AMPS. 1 IN. DIA.
SPEED OF CUTTING IN MINUTE PER FOOT				
1/2	3.5	2.0	1.5	1.0
3/4	4.7	3.0	2.0	1.4
1	6.8	4.1	2.9	2.0
1-1/4	9.8	5.6	4.0	2.9
1-1/2	...	8.0	5.8	4.0
1-3/4	8.0	5.3
2	7.0

Because of the high currents required, the graphite form of carbon electrode is better. To reduce the heating effect on the electrode, you should not let it extend more than 6 inches beyond the holder when cutting. If the carbon burns away too fast, shorten the length that it extends out of the electrode holder to as little as 3 inches. Operating a carbon electrode at extremely high temperatures causes its surface to oxidize and burn away, resulting in a rapid reduction in the electrode diameter.

Carbon-arc cutting does not require special generators. Standard arc-welding generators and other items of arc-welding station equipment are suitable for use. Straight polarity direct current (DCSP) is always used.

Because of the high temperature and the intensity of the arc, choose a shade of helmet lens that is darker than the normal shade you would use for welding on the same thickness of metal. A number 12 or 14 lens shade is recommended for carbon-arc welding or cutting.

AIR CARBON-ARC CUTTING

Air carbon-arc cutting (ACC) is a process of cutting, piercing, or gouging metal by heating it to a molten state and then using compressed air to blow away the molten metal. Figure 7-53 shows the process. The equipment consists of a special holder, as shown in figure 7-54, that uses carbon or graphite electrodes and compressed air fed through jets built into the electrode holder. A push button or a hand valve on the electrode holder controls the air jet.

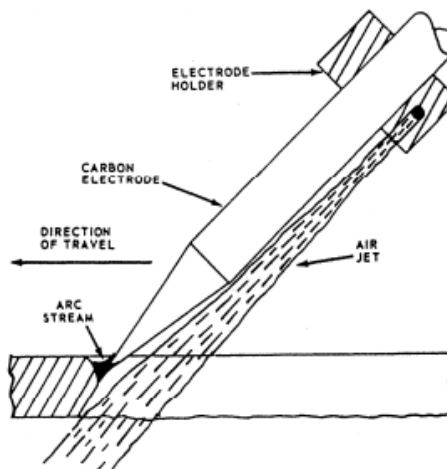

Figure 7-53.—Air carbon-arc cutting.

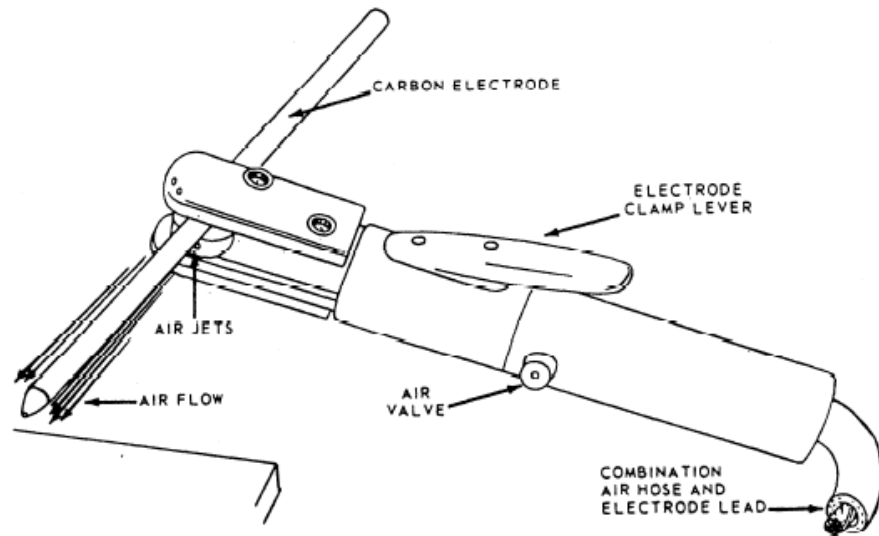

Figure 7-54.—Air carbon-arc electrode holder with carbon electrode installed.

The air jet blows the molten metal away and usually leaves a surface that needs no further preparation for welding. The electrode holder operates at air pressures varying between 60 and 100 psig.

During use, bare carbon or graphite electrodes become smaller due to oxidation caused by heat buildup. Copper coating these electrodes reduces the heat buildup and prolongs their use.

The operating procedures for air carbon-arc cutting and gouging are basically the same. The procedures are as follows:

Adjust the machine to the correct current for electrode diameter.

Start the air compressor and adjust the regulator to the correct air pressure. Use the lowest air pressure possible—just enough pressure to blow away the molten metal.

Insert the electrode in the holder. Extend the carbon electrode 6 inches beyond the holder. Ensure that the electrode point is properly shaped.

Strike the arc; then open the air-jet valve. The air-jet disc can swivel, and the V-groove in the disc automatically aligns the air jets along the electrode. The electrode is adjusted relative to the holder.

Control the arc and the speed of travel according to the shape and the condition of the cut desired.

Always cut away from the operator as molten metal sprays some distance from the cutting action. You may use this process to cut or gouge metal in the flat, horizontal, vertical, or overhead positions.

AIR CARBON-ARC GOUGING

Air carbon-arc gouging is useful in many various metalworking applications, such as metal shaping and other welding preparations. For gouging, hold the electrode holder so the electrode slopes back from the direction of travel. The air blast is directed along the electrode toward the arc. The depth and contour of the groove are controlled by the electrode angle and travel speed. The width of the groove is governed by the diameter of the electrode.

When cutting or gouging a shallow groove on the surface of a piece of metal, you should position the electrode holder at a very flat angle in relation to the work. The speed of travel and the current setting also affect the depth of the groove. The slower the movement and the higher the current, the deeper the groove. An example of a V-groove cut made in a 2-inch-thick mild steel plate by a machine-guided carbon-arc air-jet is shown in figure 7-55.

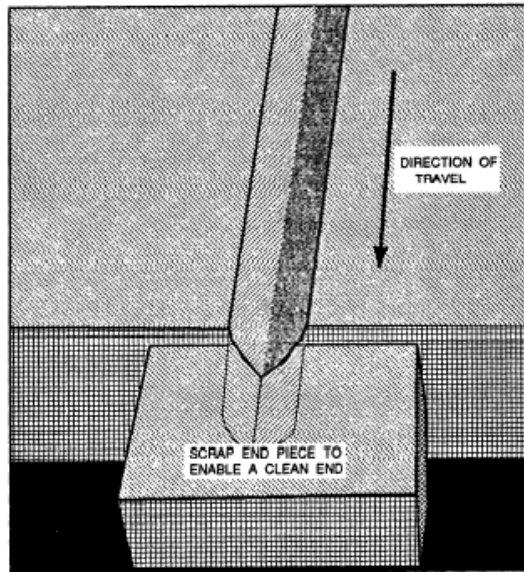

Figure 7-55.—V-groove gouged in 2-inch-thick carbon steel.

METAL ELECTRODE ARC CUTTING

Metal can be removed with the standard electric arc, but for good gouging or cutting results, you should use special metal electrodes that have been designed for this type of work. Manufacturers have developed electrodes with special coatings that intensify the arc stream for rapid cutting. The covering disintegrates at a slower rate than the metallic center. This creates a deep recess that produces a jet action that blows the molten metal away (fig. 7-56). The main disadvantage of these electrodes is that the additional metal produced must be removed.

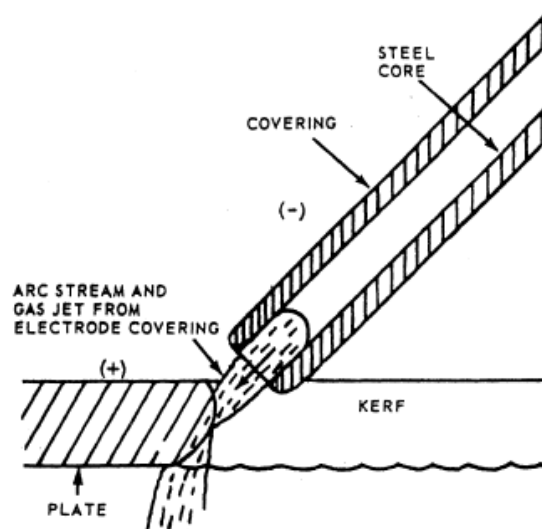

Figure 7-56.—Steel electrode being used to cut plate.

These electrodes are designed for cutting stainless steel, copper, aluminum, bronze, nickel, cast iron, manganese, steel, or alloy steels.

A typical gouge-cutting operation is shown in figure 7-57. Notice that the angle between the electrode and plate is small (5 degrees or less). This makes it easy to remove the extra metal produced by the electrode.

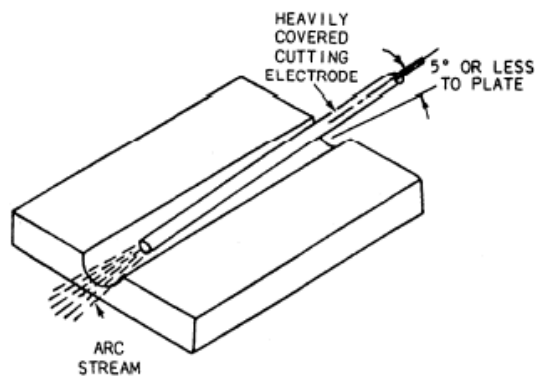

Figure 7-57.—Gouge-cutting operation using a solid core arccutting electrode.

The recommended current setting is as high as the electrode will take without becoming overheated to the point of cracking the covering.

- For 1/8-inch electrodes, the setting ranges between 125 and 300 amperes
- For 5/32-inch electrodes, the setting ranges between 250 and 375 amperes
- For 3/16-inch electrodes, the setting ranges between 300 and 450 amperes
- Use a very short arc, and when cutting takes place underwater, the coating must be waterproof.

Welding Quality Control

In the fabrication or repair of equipment, tests are used to determine the quality and soundness of the welds. Many different tests have been designed for specific faults. The type of test used depends upon the requirements of the welds and the availability of testing equipment. In this section, nondestructive and destructive testing are briefly discussed.

Nondestructive Testing

Nondestructive testing is a method of testing that does not destroy or impair the usefulness of a welded item. These tests disclose all of the common internal and surface defects that can occur when improper welding procedures are used. A large choice of testing devices is available and most of them are easier to use than the destructive methods, especially when working on large and expensive items.

Visual Inspection

Visual inspection is usually done automatically by the welder as he completes his welds. This is strictly a subjective type of inspection and usually there are no definite or rigid limits of acceptability. The welder may use templates for weld bead contour checks. Visual inspections are basically a comparison of finished welds with an accepted standard. This test is effective only when the visual qualities of a weld are the most important.

Magnetic Particle Inspection

Magnetic particle inspection is most effective for the detection of surface or near surface flaws in welds. It is used in metals or alloys in which you can induce magnetism. While the test piece is magnetized, a liquid containing finely ground iron powder is applied. As long as the magnetic field is not disturbed, the iron particles will form a regular pattern on the surface of the test piece. When the magnetic field is interrupted by a crack or some other defect in the metal, the pattern of the suspended ground metal also is interrupted. The particles of metal cluster around the defect, making it easy to locate.

You can magnetize the test piece by either having an electric current pass through it, as shown in figure 7-58, or by having an electric current pass through a coil of wire that surrounds the test piece, as shown in figure 7-59. When an electric current flows in a straight line from one contact point to the other, magnetic lines of force are in a circular direction, as shown in figure 7-58. When the current flow is through a coil around the test piece, as shown in figure 7-59, the magnetic lines of force are longitudinal through the test piece.

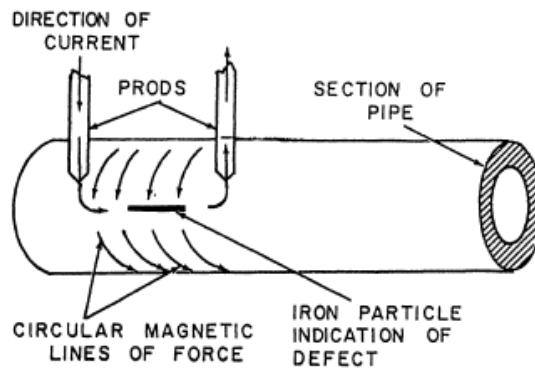

Figure 7-58.—Circular magnetization (prod method).

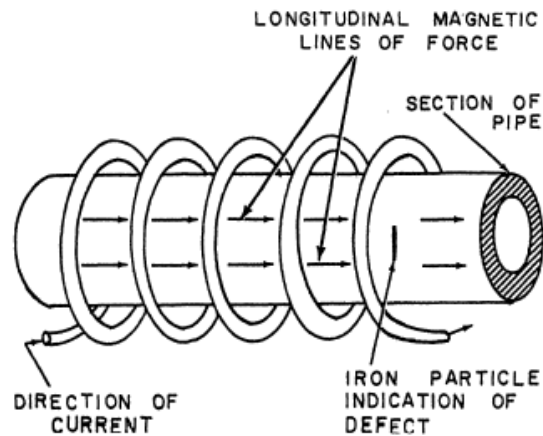

Figure 7-59.—Longitudinal magnetization (coil method).

When a defect is to show up as a disturbance in the pattern of the iron particles, the direction of the magnetic field must be at right angles to the major axis of the defect. A magnetic field having the necessary direction is established when the current flow is parallel to the major axis of the defect. Since the orientation of the defect is unknown, different current directions must be used during the test. As shown in figure 7-58, circular magnetism is induced in the test piece so you can inspect the piece for lengthwise cracks, while longitudinal magnetism, as shown in figure 7-59, is induced so you can inspect the piece for transverse cracks. In general, magnetic particle inspection is satisfactory for detecting surface cracks and subsurface cracks that are not more than 1/4 inch below the surface.

One type of magnetic particle inspection unit is a portable low-voltage unit having a maximum magnetizing output of 1,000 amperes, either alternating or direct current. It is ready to operate when plugged into the voltage supply specified by the manufacturer. The unit consists of a magnetizing current source, controls, metering, three 10-foot lengths of flexible cable, and a prod kit. The prod kit includes an insulated prod grip fitted with an ON-OFF relay or current control switch, a pair of heavy copper contact prods, and two 5-foot lengths of flexible cable. Cable fittings are designed so that either end of the cable can be connected to the unit, to the prods, or to any other cable. The three outlets on the front of the unit make changing from alternating to direct current or vice versa very easy. The outlets are labeled as follows: left is ac, the center is COMMON, and the right is dc. One cable will always be plugged into the COMMON outlet, while the other cable is plugged into either the ac or dc outlet, depending upon what type of current the test requires. For most work, alternating current magnetization effectively locates fatigue cracks and similar defects extending through to the surface. When you require a more sensitive inspection to detect defects below the surface, use direct current.

You can use the unit with alternating or direct current in either of two ways: (1) with prods attached to the flexible cable and used as contacts for the current to pass into and out of a portion of the test piece, setting up circular magnetization in the area between the prods contact points, as shown in figure 7-58; or (2) with the flexible cable wrapped around the work to form a coil that induces longitudinal magnetism in the part of the workpiece that is surrounded by the coiled cable (figure 7-59).

Although you can use either of these two methods, the prod method is probably the easier to apply. In most instances, it effectively serves to detect surface defects. With the prods, however, only a small area of the test piece can be magnetized at any one time. This magnetized area is limited to the distance between prod contact points and a few inches on each side of the current path. To check the entire surface, you must test each adjacent area by changing the location of the prod contact points. Each area of the test piece must be inspected twice—once with the current passing through the metal in one direction and then with the current passing through the metal in a direction at right angles to the direction of the first test. One of the advantages of the prod method is that the current can be easily passed through the metal in any desired direction. Thus, when a given area is suspect, magnetic fields of different directions can be induced during the test.

The prod method is accomplished by adjusting the unit for a current output suitable for the magnetizing and testing of any particular kind of metal. The current setting required depends on the distance between prod contact points. With the prod kit that is supplied with the unit, the space between prod contact points is 4 to 6 inches. A current setting between 300 and 400 amperes is satisfactory when the material thickness is less than 3/4 inch. When the material thickness is over 3/4 inch, use 400 to 600 amperes. When the prod contact points are closer together, the same magnetic field force can be obtained with less current. With prods constantly at the same spacing, more current will induce a greater field strength.

After adjusting the unit, place the prods in position. Hold them in firm contact with the metal and turn on the current. Then apply magnetic particles to the test area with the duster bulb and look for any indicator patterns. With the current still on, remove the excess particles from the test area with a blower bulb and complete the inspection. Do not move the prods until after the current has been turned off. To do so could cause the current to arc, resulting in a flash similar to that occurring in arc welding.

When you use magnetic particle inspection, hairline cracks that are otherwise invisible are readily indicated by an unmistakable outline of the defect. Large voids beneath the surface are easier to detect than small voids, but any defect below the surface is more difficult to detect than one that extends through to the surface. Since false indications frequently occur, you must be able to interpret the particle indications accurately.

The factors that help you interpret the test results include the amount of magnetizing current applied, the shape of the indication, the sharpness of the outline, the width of the pattern, and the height or buildup of the particles. Although these characteristics do not determine the seriousness of the fault, they do serve to identify the kind of defect.

The indication of a crack is a sharp, well-defined pattern of magnetic particles having a definite buildup. This

indication is produced by a relatively low-magnetizing current. Seams are revealed by a straight, sharp, fine indication. The buildup of particles is relatively weak, and the magnetizing current must be higher than that required to detect cracks. Small porosity and rounded indentations or similar defects are difficult to detect for inexperienced inspectors. A high-magnetizing current continuously applied is usually required. The particle patterns for these defects are fuzzy in outline and have a medium buildup.

The specifications governing the job determine whether or not an indicated defect is to be chipped or ground out and repaired by welding. Surface cracks are always removed and repaired. Indications of subsurface defects detected by magnetic particle inspection are evaluated by the inspector. When the indication is positive, the standard policy is to grind or chip down to solid metal and make the repair. Unless the inspector can differentiate accurately between true and false indications, the use of magnetic particle inspection should be restricted to the detection of surface defects, for which this application is almost foolproof.

After the indicated defects have been repaired, you should reinspect the areas to ensure that the repair is sound. The final step in magnetic particle inspection, is to demagnetize the workpiece. This is especially important when the workpiece is made of high-carbon steel. Demagnetization is essential when you use direct current to induce the magnetic field; however, it is not as necessary when alternating current was used in the test. In fact, the usual demagnetization procedure involves placing the workpiece in an ac coil or solenoid and slowly withdrawing it while current passes through the coil.

Demagnetization can be accomplished with the portable unit if a special demagnetizer is not available. To demagnetize with the portable unit, form a coil of flexible cable around the workpiece. Ensure that the cable is plugged into the unit for the delivery of alternating current. Set the current regulator to deliver a current identical to that used for the inspection and turn on the unit. Gradually decrease the current until the ammeter indicates zero. On large pieces, it may be necessary to demagnetize a small portion of the work at a time.

A check for the presence of a magnetic field may be made by using a small compass. A deviation of the needle from the normal position, when the compass is held near the workpiece, is an indication that a magnetic field is present. Also you can use an instrument called a field indicator to check for the presence of a magnetic field. This instrument usually comes with the magnetic particle inspection unit.

Liquid Penetrant Inspection

Liquid penetrant methods are used to inspect metals for surface defects that are similar to those revealed by magnetic particle inspection. Unlike magnetic particle inspection, which can reveal subsurface defects, liquid penetrant inspection reveals only those defects that are open to the surface. Four groups of liquid penetrants are presently in use. Group I is a dye penetrant that is non-water washable. Group II is a water washable dye penetrant. Group III and Group IV are fluorescent penetrants. Carefully follow the instructions given for each type of penetrant since there are some differences in the procedures and safety precautions required for the various penetrants.

Before using a liquid penetrant to inspect a weld, remove all slag, rust, paint, and moisture from the surface. Except where a specific finish is required, it is not necessary to grind the weld surface as long as the weld surface meets applicable specifications. Ensure the weld contour blends into the base metal without under-cutting. When a specific finish is required, perform the liquid penetrant inspection before the finish is made. This enables you to detect defects that extend beyond the final dimensions, but you must make a final liquid penetrant inspection after the specified finish has been given.

Before using a liquid penetrant, clean the surface of the material very carefully, including the areas next to the inspection area. You can clean the surface by swabbing it with a clean, lint-free cloth saturated in a non-volatile solvent or by dipping the entire piece into a solvent. After the surface has been cleaned, remove all traces of the cleaning material. It is extremely important to remove all dirt, grease, scale, lint, salts, or other materials and to make sure that the surface is entirely dry before using the liquid penetrant.

Maintain the temperature of the inspection piece and the liquid penetrant in the range of 50°F to 100°F. Do not attempt to use the liquid penetrant when this temperature range cannot be maintained. Do not use an open flame to increase the temperature because some of the liquid penetrant materials are flammable.

After thoroughly cleaning and drying the surface, coat the surface with the liquid penetrant. Spray or brush on the penetrant or dip the entire piece into the penetrant. To allow time for the penetrant to soak into all the cracks, crevices, or other defects that are open to the surface, keep the surface of the piece wet with the penetrant for a minimum of 15 or 30 minutes, depending upon the penetrant being used.

After keeping the surface wet with the penetrant for the required length of time, remove any excess penetrant from the surface with a clean, dry cloth, or absorbent paper towel. Then dampen a clean, lint-free material with penetrant remover and wipe the remaining excess penetrant from the test surface. Next, allow the test surface to dry by normal evaporation or wipe it dry with a clean, lint-free absorbent material. In drying the surface, avoid contaminating it with oil, lint, dust, or other materials that would interfere with the inspection.

After the surface has dried, apply another substance, called a developer. Allow the developer (powder or liquid) to stay on the surface for a minimum of 7 minutes before starting the inspection. Leave it on no longer than 30 minutes, thus allowing a total of 23 minutes to evaluate the results.

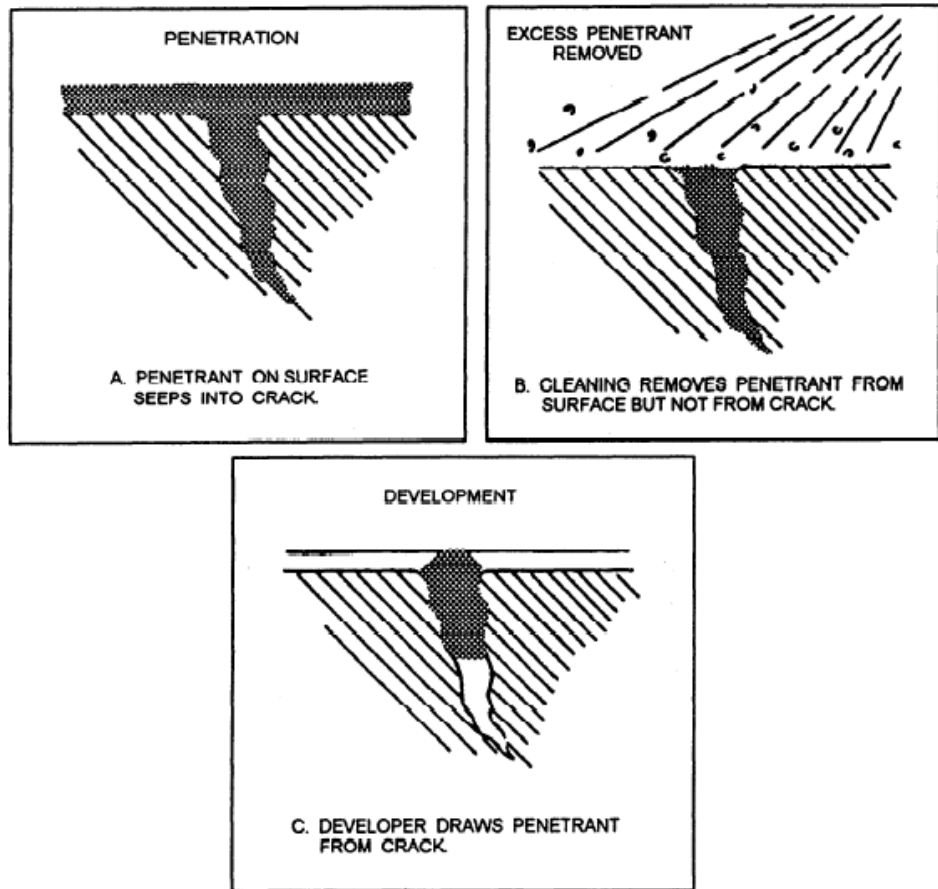

Figure 7-60.—Liquid penetrant inspection.

The following actions take place when using dye penetrants. First, the penetrant that is applied to the surface of the material will seep into any passageway open to the surface, as shown in figure 7-60, view A.

The penetrant is normally red in color, and like penetrating oil, it seeps into any crack or crevice that is open to the surface. Next, the excess penetrant is removed from the surface of the metal with the penetrant remover and a lint-free absorbent material. Only the penetrant that has seeped into the defect is left (fig. 7-60, view B), leaving the penetrant that has seeped into the defect.

Finally, the white developer is applied to the surface of the metal, as shown in figure 7-60, view C. The developer is an absorbing material that actually draws the penetrant from the defect. Therefore, the red penetrant indications in the white developer represent the defective areas. The amount of red penetrant drawn from the defective areas indicates the size and some-times the type of defect. When you use dye penetrants, the lighting in the test area must be bright enough to enable you to see any indications of defects on the test surface.

The indications you see during a liquid penetrant inspection must be carefully interpreted and evaluated. In almost every inspection, some insignificant indications are present. Most of these are the result of the failure to remove all the excess penetrant from the surface. At least 10 percent of all indications must be removed from the surface to determine whether defects are actually present or whether the indications are the result of excess penetrant. When a second inspection does not reveal indications in the same locations, it is usually safe to assume that the first indications were false.

Remove all penetrant inspection materials as soon as possible after the final inspection has been made. Use water or solvents, as appropriate. Since some of the liquid penetrant materials are flammable, do not use them near open flames, and do not apply them to any surface that is at a temperature higher than 100°F. In addition to being flammable, many solvents are poisonous in the vapor form and highly irritating to the skin in the liquid form.

Radiographic Inspection

Radiographic inspection is a method of inspecting weldments by the use of rays that penetrate through the welds. X rays or gamma rays are the two types of waves used for this process. The rays pass through the weld and onto a sensitized film that is in direct contact with the back of the weld. When the film is developed, gas pockets, slag inclusions, cracks, or poor penetration will be visible on the film.

Because of the danger of these rays, only qualified personnel are authorized to perform these tests. As Seabees, you will rarely come in contact with these procedures.

Ultrasonic Inspection

Ultrasonic inspection of testing uses high-frequency vibrations or waves to locate and measure defects in welds. It

can be used in both ferrous and nonferrous materials. This is an extremely sensitive system and can locate very fine surface and subsurface cracks as well as other types of defects. All types of joints can be tested.

This process uses high-frequency impulses to check the soundness of the weld. In a good weld, the signal travels through the weld to the other side and is then reflected back and shown on a calibrated screen. Irregularities, such as gas pockets or slag inclusions, cause the signal to reflect back sooner and will be displayed on the screen as a change in depth. When you use this system, most all types of materials can be checked for defects. Another advantage of this system is that only one side of the weld needs to be exposed for testing.

Eddy Current Testing

Eddy current is another type of testing that uses electromagnetic energy to detect faults in weld deposits and is effective for both ferrous and nonferrous materials. Eddy current testing operates on the principle that whenever a coil carrying a high-frequency alternating current is placed next to a metal, an electrical current is produced in the metal by induction. This induced current is called an eddy current.

The test piece is exposed to electromagnetic energy by being placed in or near high-frequency ac current coils. The differences in the weld cause changes in the impedance of the coil, and this is indicated on electronic instruments. When there are defects, they show up as a change in impedance, and the size of the defect is shown by the amount of this change.

Destructive Testing

In destructive testing, sample portions of the welded structures are required. These samples are subjected to loads until they actually fail. The failed pieces are then studied and compared to known standards to determine the quality of the weld. The most common types of destructive testing are known as free bend, guided bend, nick-break, impact, fillet welded joint, etching, and tensile testing. The primary disadvantage of destructive testing is that an actual section of a weldment must be destroyed to evaluate the weld. This type of testing is usually used in the certification process of the welder.

Some of the testing requires elaborate equipment that is not available for use in the field. Three tests that may be performed in the field without elaborate equipment are the free-bend test, the guided-bend test, and the nick-break test.

Free-Bend Test

The FREE-BEND TEST is designed to measure the ductility of the weld deposit and the heat-affected area adjacent to the weld. Also it is used to determine the percentage of elongation of the weld metal. Ductility, you should recall, is that property of a metal that allows it to be drawn out or hammered thin.

The first step in preparing a welded specimen for the free-bend test is to machine the welded reinforcement crown flush with the surface of the test plate. When the weld area of a test plate is machined, as is the case of the guided-bend as well as in the free-bend test, perform the machining operation in the opposite direction that the weld was deposited.

The next step in the free-bend test is to scribe two lines on the face of the filler deposit. Locate these lines 1/16 inch from each edge of the weld metal, as shown in figure 7-61, view B. Measure the distance, in inches, between the lines to the nearest 0.01 inch and let the resulting measurement equal (x). Then bend the ends of the test specimen until each leg forms an angle of 30 degrees to the original centerline. With the scribed lines on the outside and the piece placed so all the bending occurs in the weld, bend the test piece by using a hydraulic press or similar machine.

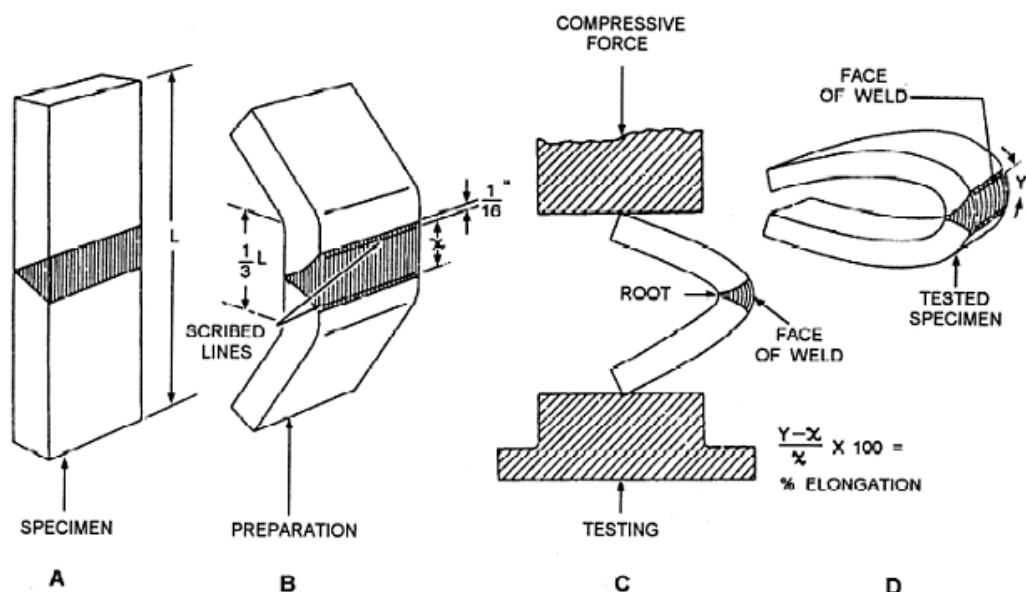

Figure 7-61.—Free-bend test

When the proper precautions are taken, a blacksmith's forging press or hammer can be used to complete the bending operation. If a crack more than 1/16 inch develops during the test, stop the bending because the weld has failed; otherwise, bend the specimen flat. After completing the test, measure the distance between the scribed lines and call that measurement (y). The percentage of elongation is then determined by the formula:

$$\frac{Y-X}{X} \times 100 = \% \text{ elongation}$$

Requirements for a satisfactory test area minimum elongation of 15 percent and no cracks greater than 1/16 inch on the face of the weld.

Guided-Bend Test

You use the GUIDED-BEND TEST to determine the quality of weld metal at the face and root of a welded joint. This test is made in a specially designed jig. An example of one type of jig is shown in figure 7-62.

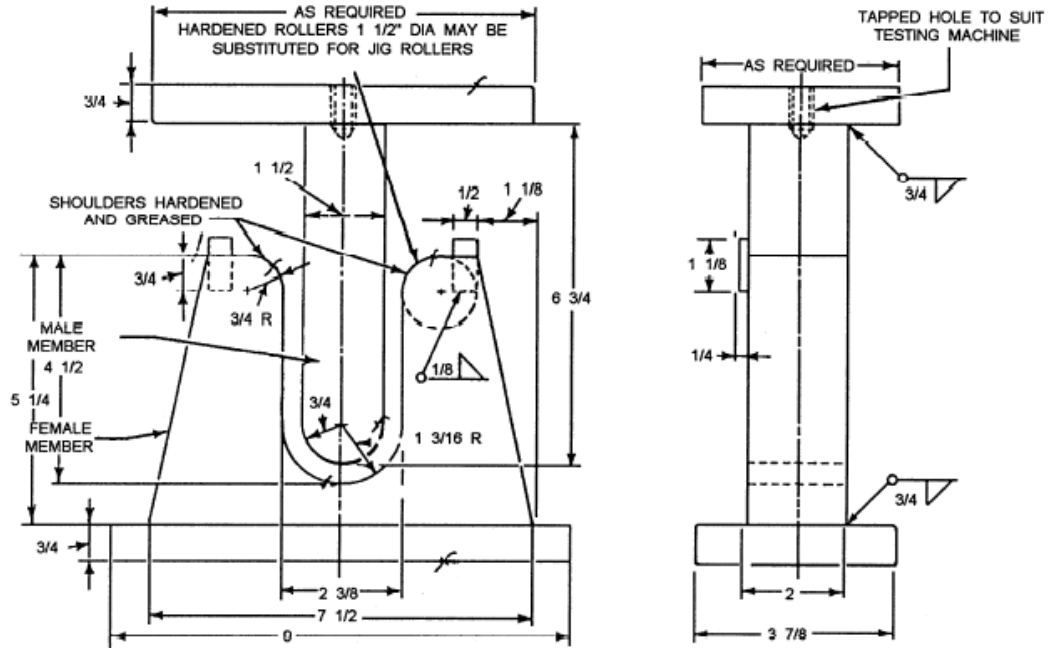

Figure 7-62.—Guided-bend test jig.

The test specimen is placed across the supports of the die. A plunger, operated from above by hydraulic pressure, forces the specimen into the die. To fulfill the requirements of this test, you must bend the specimen 180 degrees—the capacity of the jig. No cracks should appear on the surface greater than 1/8 inch. The face-bend tests are made in this jig with the face of the weld in tension (outside), as shown in figure 7-63. The root-bend tests are made with the root of the weld in tension (outside), as shown in figure 7-63.

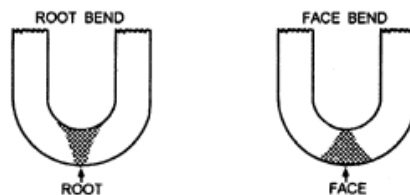

Figure 7-63.—Guided-bend test specimens.

Figure 7-64 shows a machine used for making the guided-bend test. It is used in many welding schools and testing laboratories for the daily testing of specimens. Simple in construction and easy to use, it works by hydraulic pressure and can apply a direct load up to 40,000 pounds, and even more on small specimens. When you make the test, position the specimen in the machine as previously indicated and start pumping the actuator. Keep your eye on the large gauge and watch the load increase. You will know the actual load under which the test piece bends by the position of an auxiliary hand that is carried along by the gauge pointer. The hand remains at the point of maximum load after the pointer returns to zero.



Figure 7-64.—Testing machine for making guided-bend tests.
(Courtesy [PCES Limited](#))

Nick-Break Test

The NICK-BREAK TEST is useful for determining the internal quality of the weld metal. This test reveals various internal defects (if present), such as slag inclusions, gas pockets, lack of fusion, and oxidized or burned metal. To accomplish the nick-break test for checking a butt weld, you must first flame-cut the test specimens from a sample weld (fig. 7-65). Make a saw cut at each edge through the center of the weld. The depth of cut should be about $\frac{1}{4}$ inch.

Next, place the saw-nicked specimen on two steel supports, as shown in figure 7-65. Using a heavy hammer, break the specimen by striking it in the zone where you made the saw cuts. The weld metal exposed in the break should be completely fused, free from slag inclusions, and contain no gas pockets greater than $\frac{1}{16}$ inch across their greatest dimension. There should not be more than six pores or gas pockets per square inch of exposed broken surface of the weld.

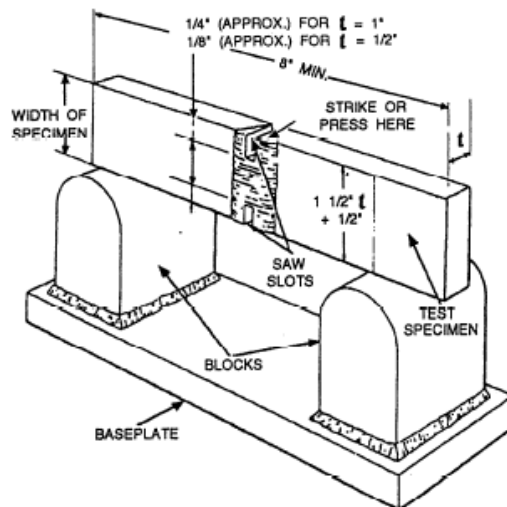

Figure 7-65.—Nick-break test of a butt weld.

Impact Test

You use the IMPACT TEST to check the ability of a weld to absorb energy under impact without fracturing. This is a dynamic test in which a test specimen is broken by a single blow, and the energy used in breaking the piece is measured in foot-pounds. This test compares the toughness of the weld metal with the base metal. It is useful in finding if any of the mechanical properties of the base metal were destroyed by the welding process.

The two kinds of specimens used for impact testing are known as Charpy and Izod (fig. 7-66). Both test pieces are broken in an impact testing machine. The only difference is in the manner that they are anchored. The Charpy piece is supported horizontally between two anvils and the pendulum strikes opposite the notch, as shown in figure 7-67, view A. The Izod piece is supported as a vertical cantilever beam and is struck on the free end projecting over the holding vise (fig. 7-67, view B).

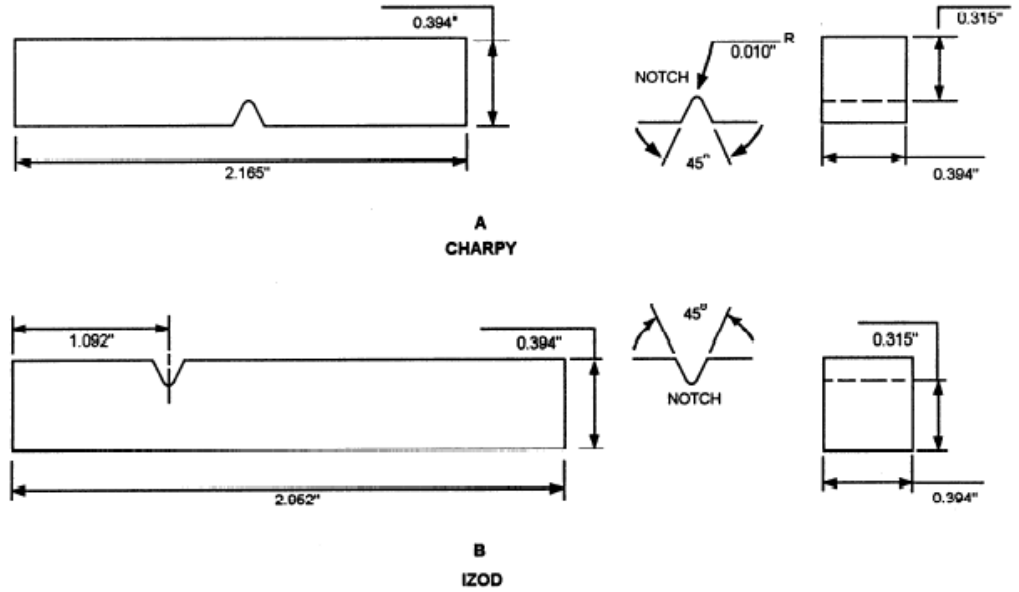

Figure 7-66.—Test pieces for impact testing.

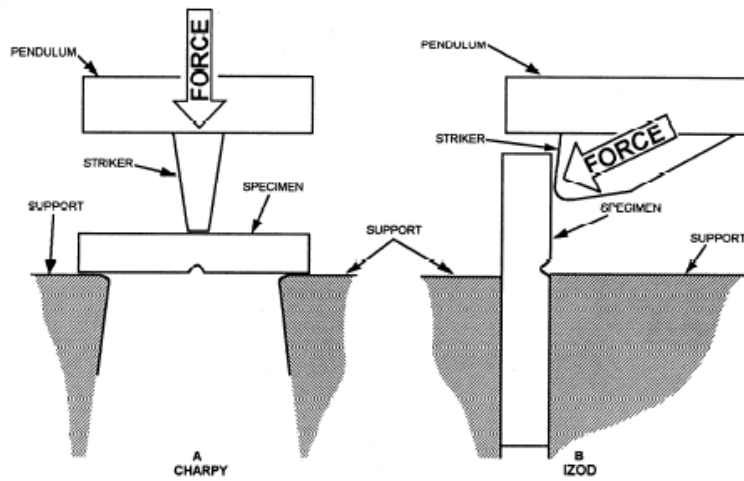

Figure 7-67.—Performing impact test.

Fillet-Welded Joint Test

You use the FILLET-WELDED JOINT TEST to check the soundness of a fillet weld. Soundness refers to the degree of freedom a weld has from defects found by visual inspection of any exposed welding surface. These defects include penetrations, gas pockets, and inclusions. Prepare the test specimen, as shown in figure 7-68. Now apply force (fig. 7-69) until a break occurs in the joint. This force may be applied by hydraulics or hammer blows.

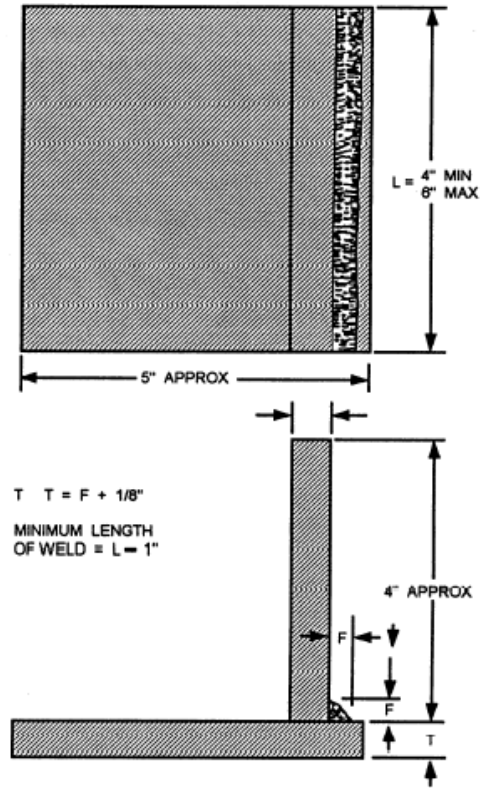

Figure 7-68.—Test plate for fillet weld test.

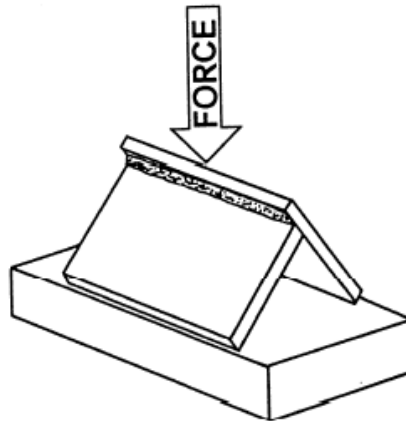

Figure 7-69.—Rupturing fillet weld test plate.

In addition to checking the fractured weld for soundness, now is a good time to etch the weld to check for cracks.

Etching Test

The ETCHING TEST is used to determine the soundness of a weld and also make visible the boundary between the base metal and the weld metal.

To accomplish the test, you must cut a test piece from the welded joint so it shows a complete transverse section of the weld. You can make the cut by either sawing or flame cutting. File the face of the cut and then polish it with grade 00 abrasive cloth. Now place the test piece in the etching solution.

The etching solutions generally used are hydrochloric acid, ammonium persulfate, iodine and potassium iodide, or nitric acid. Each solution highlights different defects and areas of the weld. The hydrochloric acid dissolves slag inclusions and enlarges gas pockets, while nitric acid is used to show the refined zone as well as the metal zone.

Tensile Strength Test

The term TENSILE STRENGTH may be defined as the resistance to longitudinal stress or pull and is measured in pounds per square inch of cross section. Testing for tensile strength involves placing a weld sample in a tensile testing machine and pulling on the test sample until it breaks.

The essential features of a tensile testing machine are the parts that pull the test specimen and the devices that measure the resistance of the test specimen. Another instrument, known as an extensometer or strain gauge, is

also used to measure the strain in the test piece. Some equipment comes with a device that records and plots the stress-strain curve for a permanent record.

The tensile test is classified as a destructive test because the test specimen must be loaded or stressed until it fails. Because of the design of the test machine, weld samples must be machined to specific dimensions.

This explains why the test is made on a standard specimen, rather than on the part itself. It is important that the test specimen represents the part. Not only must the specimen be given the same heat treatment as the part but it also must be heat-treated at the same time.

There are many standard types of tensile test specimens, and figure 7-70 shows one standard type of specimen commonly used. The standard test piece is an accurately machined specimen. Overall length is not a critical item, but the diameter and gauge length are. The 0.505-inch-diameter (0.2 square inch area) cross section of the reduced portion provides an easy factor to manipulate arithmetically. The 2-inch gauge length is the distance between strain-measuring points. This is the portion of the specimen where you attach the extensometer. In addition, you can use the gauge length to determine percent elongation.

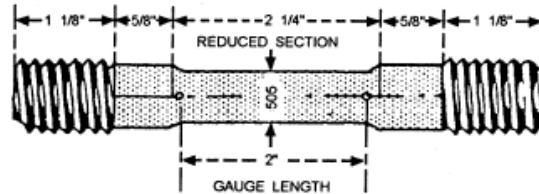

Figure 7-70.—Standard tensile test specimen.

The tensile test amounts to applying a smooth, steadily increasing load (or pull) on a test specimen and measuring the resistance of the specimen until it breaks. Even if recording equipment is not available, the test is not difficult to perform. During the test, you observe the behavior of the specimen and record the extensometer and gauge readings at regular intervals. After the specimen breaks and the fracturing load is recorded, you measure the specimen with calipers to determine the percent of elongation and the percent reduction in area. In addition, you should plot a stress-strain curve. From the data obtained, you can determine tensile strength, yield point, elastic limit, modulus of elasticity, and other properties of the material.

Safety Regulations

You, as the welder, must have a thorough knowledge of the safety precautions relating to the job. That is not all; you should also consider it your responsibility to observe all of the applicable safety precautions. When welding, carelessness can cause serious injury to your-self as well as others.

Bear in mind the safety precautions for operating welding equipment can vary considerably because of the different types of equipment involved; therefore, only general precautions on operating metal arc-welding equipment are presented here. For specific instructions on the operation and maintenance of your individual equipment, consult the equipment manufacturer's instruction manual. In regards to general precautions, know your equipment and how to operate it. Use only approved welding equipment, and ensure that it is maintained properly.

Before you start welding, ensure that the welding machine frame is grounded, that neither terminal of the welding generator is bonded to the frame, and that all electrical connections are secure. The ground connection must be attached firmly to the work, not merely laid loosely upon it.

- Keep welding cables dry and free of oil or grease.
- Keep the cables in good condition and always take appropriate steps to protect them from damage. When it is necessary to run cables some distance from the machine, lay them overhead, if at all possible, using adequate support devices.
- When you are using portable machines, make sure that the primary power cable is separate from the welding cables so they do not become entangled. Any portable equipment mounted on wheels should be securely blocked to prevent accidental movement during welding operations.
- When stopping work for any appreciable length of time, be sure to de-energize the equipment. When the equipment is not in use, you should completely disconnect it from its source of power.
- Keep the work area neat and clean. If at all possible, make it a practice to dispose the hot electrode stubs in a metal container.

[Return to the Table of Contents](#)

Molybdenum Supplier

TZM, Tungsten, Molybdenum. Rods, Sheets, Tubes, Electrodes...

