

Welding99.asp
fra03



[FAQ](#) - [About](#) - [Contact Us](#) - [Tell A Friend](#) - [Free-Ed.Net Home](#)

SHARE   

[Return to the Table of Contents](#)



Molybdenum Supplier

TZM, Tungsten,
Molybdenum.
Rods, Sheets,
Tubes, Electrodes...



Lesson 3 Introduction to Welding

Welding is widely used by metalworkers in the fabrication, maintenance, and repair of parts and structures. While there are many methods for joining metals, welding is one of the most convenient and rapid methods available. The term welding refers to the process of joining metals by heating them to their melting temperature and causing the molten metal to flow together. These range from simple steel brackets to nuclear reactors.

Welding, like any skilled trade, is broad in scope and you cannot become a welder simply by reading a book. You need practice and experience as well as patience; however, much can be gained through study. For instance, by learning the correct method or procedure for accomplishing a job from a book, you may eliminate many mistakes that otherwise would occur through trial and error.

This lesson is designed to equip you with a background of basic information applicable to welding in general. If you take time to study this material carefully, it will provide you with the foundation needed to become a skilled welder.

Welding Processes

Welding is not new. The earliest known form of welding, called forge welding, dates back to the year 2000 B.C. Forge welding is a primitive process of joining metals by heating and hammering until the metals are fused (mixed) together. Although forge welding still exists, it is mainly limited to the blacksmith trade.

Today, there are many welding processes available. Figure 3-1 provides a list of processes used in modern metal fabrication and repair. This list, published by the American Welding Society (AWS), shows the official abbreviations for each process. For example, RSW stands for resistance spot welding. Shielded metal arc welding (SMAW) is an arc-welding process that fuses (melts) metal by heating it with an electric arc created between a covered metal electrode and the metals being joined. Of the welding processes listed in figure 3-1, shielded metal arc welding, called stick welding, is the most common welding process. The primary differences between the various welding processes are the methods by which heat is generated to melt the metal. Once you understand the theory of welding, you can apply it to most welding processes.

The most common types of welding are oxyfuel gas welding (OFW), arc welding (AW), and resistance welding (RW). As a welder, your primary concern is gas and arc welding. The primary difference between these two processes is the method used to generate the heat.

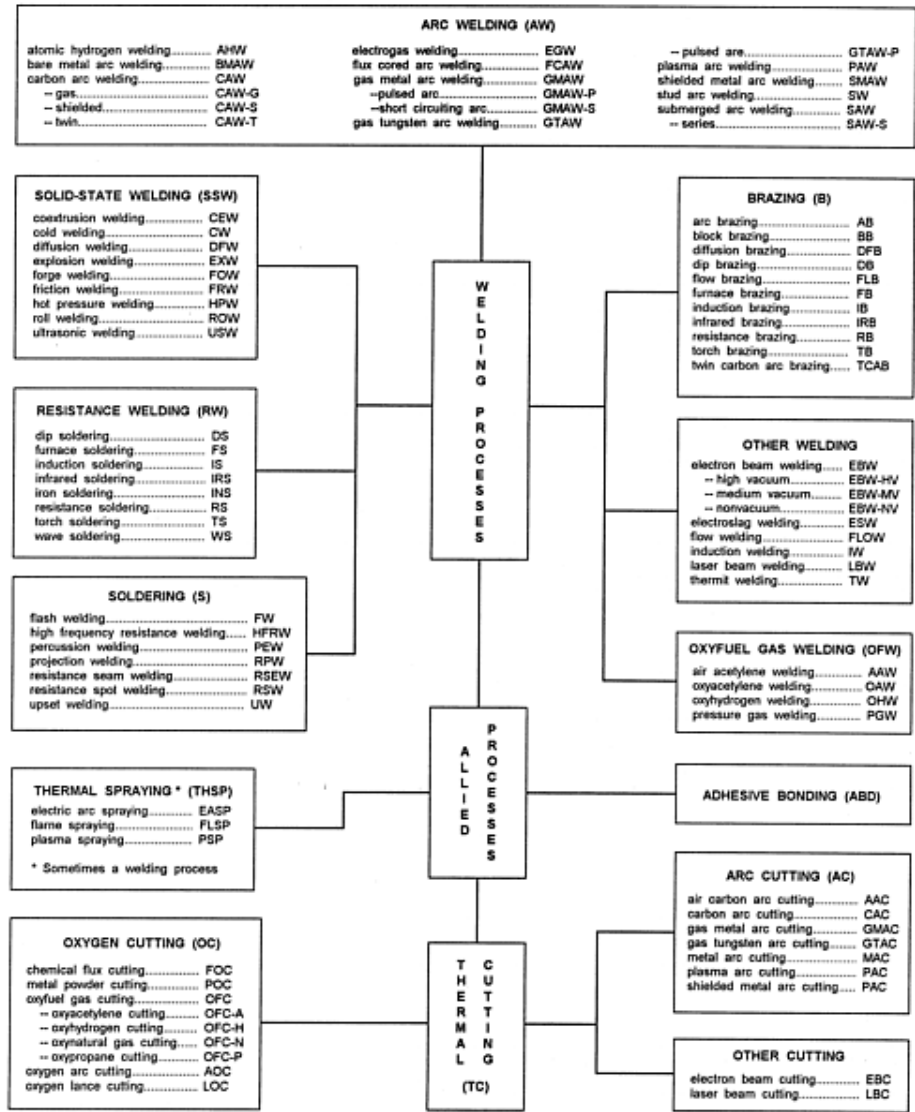

Figure 3-1.—Welding processes.

Gas Welding

One of the most popular welding methods uses a gas flame as a source of heat. In the oxyfuel gas welding process (fig. 3-2), heat is produced by burning a combustible gas, such as MAPP (methylacetylene-propadi-ene) or acetylene, mixed with oxygen. Gas welding is widely used in maintenance and repair work because of the ease in transporting oxygen and fuel cylinders. Once you learn the basics of gas welding, you will find the oxyfuel process adaptable to brazing, cutting, and heat treating all types of metals. You will learn more about gas welding in lesson 5.

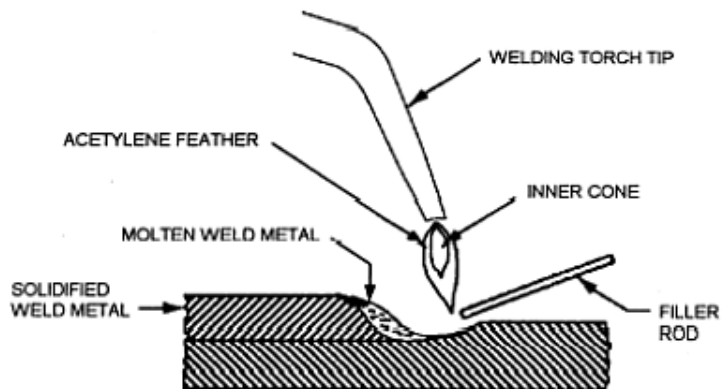

Figure 3-2.—Oxyfuel gas welding (OFW).

Arc Welding

Arc welding is a process that uses an electric arc to join the metals being welded. A distinct advantage of arc welding over gas welding is the concentration of heat. In gas welding the flame spreads over a large area, sometimes causing heat distortion. The concentration of heat, characteristic of arc welding, is an advantage because less heat spread reduces buckling and warping. This heat concentration also increases the depth of penetration and speeds up the welding operation; therefore, you will find that arc welding is often more practical and economical than gas welding.

All arc-welding processes have three things in common: a heat source, filler metal, and shielding. The source of heat in arc welding is produced by the arcing of an electrical current between two contacts. The power source is called a welding machine or simply, a welder. This should not be confused with the same term that is also used to describe the person who is performing the welding operation. The welder (welding machine) is either electric- or motor-powered. In the Naval Construction Force (NCF), there are two main types of arc-welding processes with which you should become familiar. They are shielded metal arc welding and gas shielded arc welding.

Shielded Metal Arc Welding (SMAW)

Shielded metal arc welding (fig. 3-3) is performed by striking an arc between a coated-metal electrode and the base metal. Once the arc has been established, the molten metal from the tip of the electrode flows together with the molten metal from the edges of the base metal to form a sound joint. This process is known as fusion. The coating from the electrode forms a covering over the weld deposit, shielding it from contamination; therefore the process is called shielded metal arc welding. The main advantages of shielded metal arc welding are that high-quality welds are made rapidly at a low cost. You will learn more about shielded metal arc welding in a later lesson.

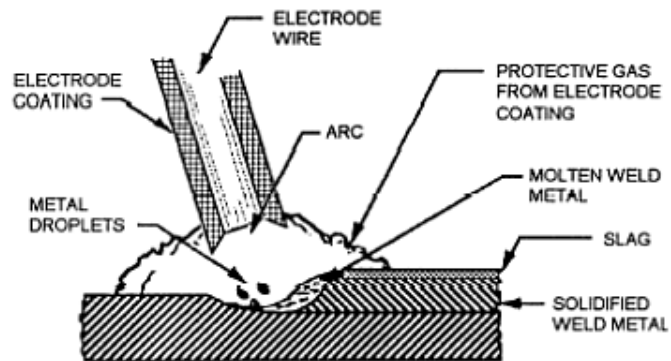

Figure 3-3.—Shielded metal arc welding (SMAW).

Gas Shielded Arc Welding

The primary difference between shielded metal arc welding and gas shielded arc welding is the type of shielding used. In gas shielded arc welding, both the arc and the molten puddle are covered by a shield of inert gas. The shield of inert gas prevents atmospheric contamination, thereby producing a better weld. The primary gases used for this process are helium, argon, or carbon dioxide. In some instances, a mixture of these gases is used. The processes used in gas shielded arc welding are known as gas tungsten arc welding (GTAW) (fig. 3-4) and gas metal arc welding (GMAW) (fig. 3-5). You will also hear these called "TIG" and "MIG." Gas shielded arc welding is extremely useful because it can be used to weld all types of ferrous and nonferrous metals of all thicknesses.

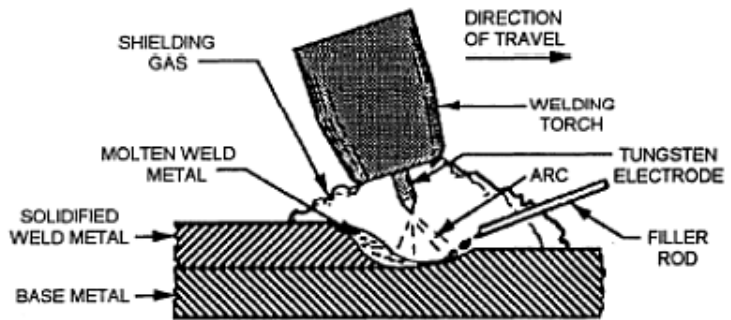
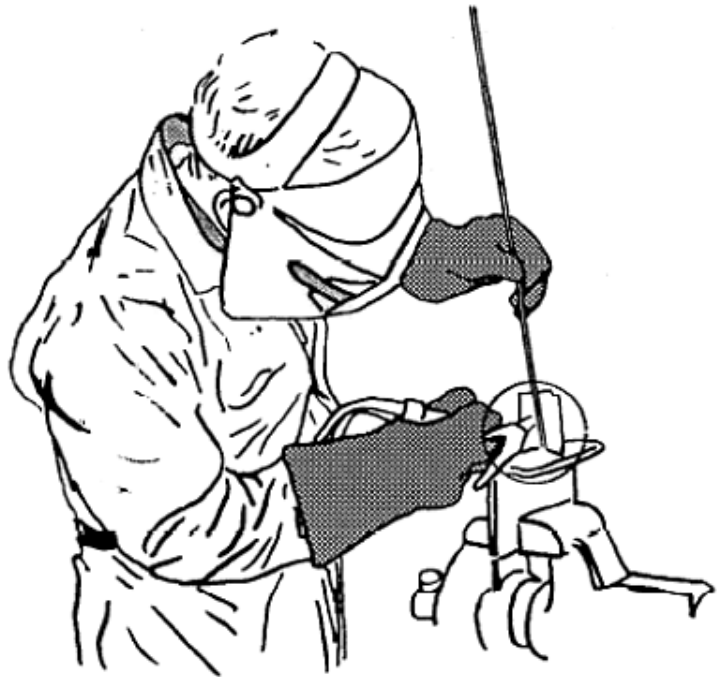

Figure 3-4.—Gas tungsten arc welding (GTAW).

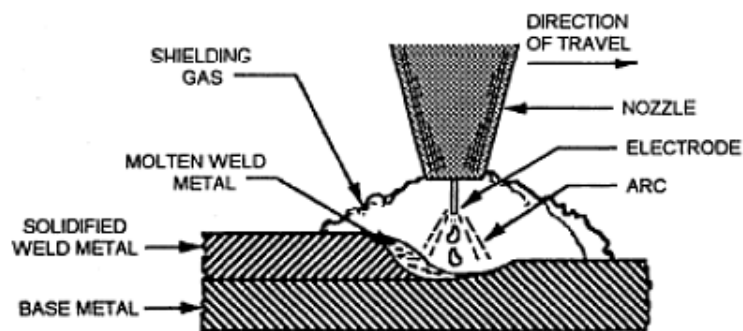

Figure 3-5.—Gas metal arc welding (GMAW).

Now that we have discussed a few of the welding processes available, which one should you choose? There are no hard-and-fast rules. In general, the controlling factors are the types of metal you are joining, cost involved, nature of the products you are fabricating, and the techniques you use to fabricate them. Because of its flexibility and mobility, gas welding is widely used for maintenance and repair work in the field. On the other hand, you should probably choose gas shielded metal arc welding to repair a critical piece of equipment made from aluminum or stainless steel.

No matter what welding process you use, there is some basic information you need to know. The remainder of this chapter is devoted to this type of information. Study this information carefully because it allows you to follow welding instructions, read welding symbols, and weld various types of joints using the proper welding techniques.

Welding Terminology

To become a skilled welder, you first need to learn the technical vocabulary (language) of welding. The sections in this chapter introduce you to some of the basic terms of the welding language. Once you understand the language of welding, you will be prepared to interpret and communicate welding information accurately.

FILLER METALS

When welding two pieces of metal together, you often have to leave a space between the joint. The material that you add to fill this space during the welding process is known as the filler metal, or material. Two types of filler metals commonly used in welding are welding rods and welding electrodes.

The term welding rod refers to a form of filler metal that does not conduct an electric current during the welding process. The only purpose of a welding rod is to supply filler metal to the joint. This type of filler metal is often used for gas welding.

In electric-arc welding, the term electrode refers to the component that conducts the current from the electrode holder to the metal being welded. Electrodes are classified into two groups: consumable and non-consumable. Consumable electrodes not only provide a path for the current

but they also supply filler metal to the joint. An example is the electrode used in shielded metal-arc welding. Non-consumable electrodes are only used as a conductor for the electrical current, such as in gas tungsten arc welding. The filler metal for gas tungsten arc welding is a hand fed consumable welding rod.

FLUXES

Before performing any welding process, you must ensure the base metal is clean. No matter how much the base metal is physically cleaned, it still contains impurities. These impurities, called oxides, result from oxygen combining with the metal and other contaminants in the base metal. Unless these oxides are removed by using a proper flux, a faulty weld may result. The term flux refers to a material used to dissolve oxides and release trapped gases and slag (impurities) from the base metal; thus the flux can be thought of as a cleaning agent. In performing this function, the flux allows the filler metal and the base metal to be fused.

Different types of fluxes are used with different types of metals; therefore, you should choose a flux formulated for a specific base metal. Beyond that, you can select a flux based on the expected soldering, brazing

, or welding temperature; for example, when brazing, you should select a flux that becomes liquid at the correct brazing temperature. When it melts, you will know it is time to add the filler metal. The ideal flux has the right fluidity at the welding temperature and thus blankets the molten metal from oxidation.

Fluxes are available in many different forms. There are fluxes for oxyfuel gas applications, such as brazing and soldering. These fluxes usually come in the form of a paste, powder, or liquid. Powders can be sprinkled on the base metal, or the filler rod can be heated and dipped into the powder. Liquid and paste fluxes can be applied to the filler rod and to the base metal with a brush. For shielded metal arc welding, the flux is on the electrode. In this case, the flux combines with impurities in the base metal, floating them away in the form of a heavy slag which shields the weld from the atmosphere.

You should realize that no single flux is satisfactory for universal use; however, there are a lot of good general-purpose fluxes for use with common metals. In general, a good flux has the following characteristics: It is fluid and active at the melting point of the filler metal.

- It remains stable and does not change to a vapor rapidly within the temperature range of the welding procedure.
- It dissolves all oxides and removes them from the joint surfaces.
- It adheres to the metal surfaces while they are being heated and does not ball up or blow away.
- It does not cause a glare that makes it difficult to see the progress of welding or brazing.
- It is easy to remove after the joint is welded.
- It is available in an easily applied form.

CAUTION

Nearly all fluxes give off fumes that may be toxic. Use ONLY in well-ventilated spaces. It is also good to remember that ALL welding operations require adequate ventilation whether a flux is used or not.

WELD JOINTS

The weld joint is where two or more metal parts are joined by welding. The five basic types of weld joints are the butt, corner, tee, lap, and edge, as shown in figure 3-6.

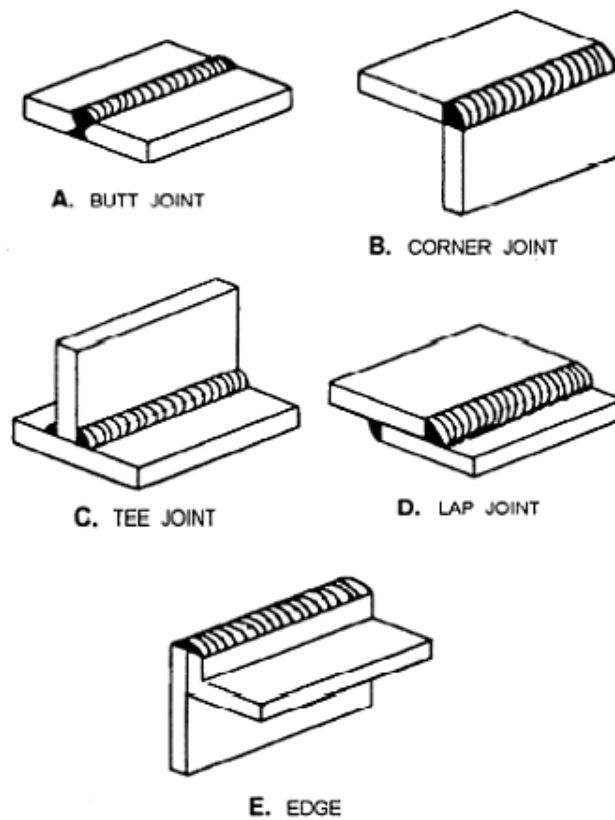

Figure 3-6.—Basic weld joints.

A **butt** joint is used to join two members aligned in the same plane (fig. 3-6, view A). This joint is frequently used in plate, sheet metal, and pipe work. A joint of this type may be either square or grooved. Some of the variations of this joint are discussed later in this lesson.

Corner and **tee** joints are used to join two members located at right angles to each other (fig. 3-6, views B and C). In cross section, the corner joint forms an L-shape, and the tee joint has the shape of the letter T. Various joint designs of both types have uses in many types of metal structures.

A **lap** joint, as the name implies, is made by lapping one piece of metal over another (fig. 3-6, view D). This is one of the strongest types of joints available; however, for maximum joint efficiency, you should overlap the metals a minimum of three times the thickness of the thinnest member you are joining. Lap joints are commonly used with torch brazing and spot welding applications.

An **edge** joint is used to join the edges of two or more members lying in the same plane. In most cases, one of the members is flanged, as shown in figure 3-6, view E. While this type of joint has some applications in platework, it is more frequently used in sheet metal work. An edge joint should only be used for joining metals 1/4 inch or less in thickness that are not subjected to heavy loads.

The above paragraphs discussed only the five basic types of joints; however, there are many possible variations. Later in this lesson, we discuss some of these variations.

PARTS OF JOINTS

While there are many variations of joints, the parts of the joint are described by standard terms. The **root** of a joint is that portion of the joint where the metals are closest to each other. As shown in figure 3-7, the root may be a point, a line, or an area, when viewed in cross section. A **groove** (figure 3-8) is an opening or space provided between the edges of the metal parts to be welded. The **groove face** is that surface of a metal part included in the groove, as shown in figure 3-8, view A. A given joint may have a root face or a root edge. The **root face**, also shown in view A, is the portion of the prepared edge of a part to be joined by a groove weld that has not been grooved. As you can see, the root face has relatively small dimensions. The root edge is basically a root face of zero width, as shown in view B. As you can see in views C and D of the illustration, the groove face and the root face are the same metal surfaces in some joints.

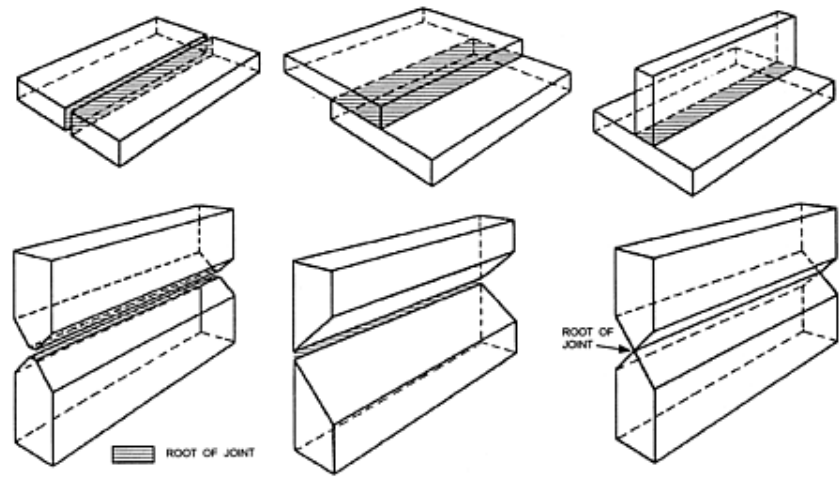

Figure 3-7.—Root of joint.

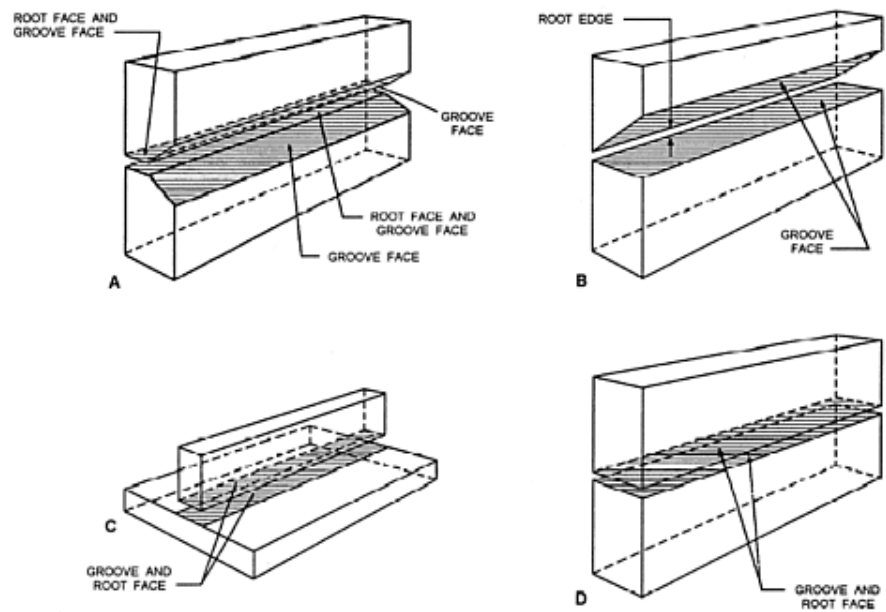

Figure 3-8.—The groove face, root face, and root edge of joints.

The specified requirements for a particular joint are expressed in such terms as bevel angle, groove angle, groove radius, and root opening. A brief description of each term is shown in figure 3-9.

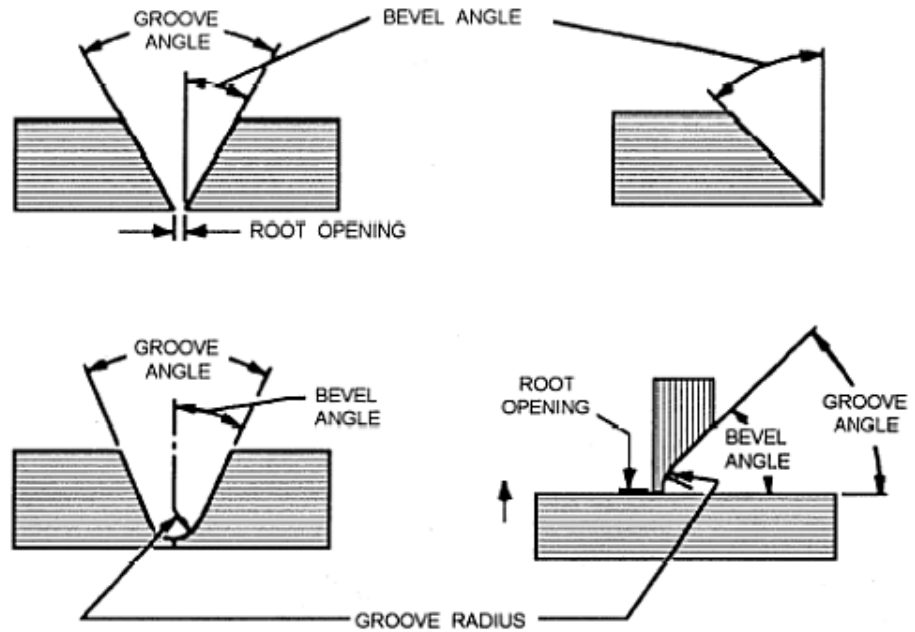

Figure 3-9.—Bevel angle, groove angle, groove radius, and root opening of joints for welding.

The **bevel angle** is the angle formed between the prepared edge of a member and a plane perpendicular to the surface of the member.

The **groove angle** is the total angle of the groove between the parts to be joined. For example, if the edge of each of two plates were beveled to an angle of 30 degrees, the groove angle would be 60 degrees. This is often referred to as the “included angle” between the parts to be joined by a groove weld.

The **groove radius** is the radius used to form the shape of a J- or U-groove weld joint. It is used only for special groove joint designs.

The **root opening** refers to the separation between the parts to be joined at the root of the joint. It is sometimes called the “root gap.”

To determine the bevel angle, groove angle, and root opening for a joint, you must consider the thickness of the weld material, the type of joint to be made, and the welding process to be used. As a general rule, gas welding requires a larger groove angle than manual metal-arc welding.

The root opening is usually governed by the diameter of the filler material. This, in turn, depends on the thickness of the base metal and the welding position. Having an adequate root opening is essential for root penetration.

Root penetration and joint penetration of welds are shown in figure 3-10. Root penetration refers to the depth that a weld extends into the root of the joint. Root penetration is measured on the center line of the root cross section. **Joint penetration** refers to the minimum depth that a groove (or a flange) weld extends from its face into a joint, exclusive of weld reinforcement. As you can see in the figure, the terms, *root penetration* and *joint penetration*, often refer to the same dimension. This is the case in views A, C, and E of the illustration. View B, however, shows the difference between root penetration and joint penetration. View D shows joint penetration only. *Weld reinforcement* is a term used to describe weld metal in excess of the metal necessary to fill a joint. (See fig. 3-11.)

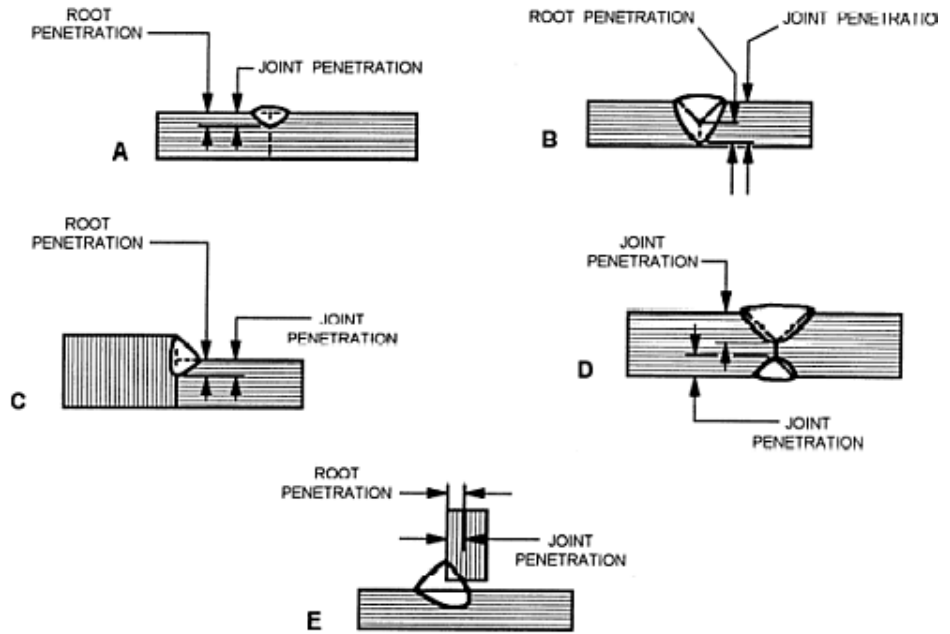

Figure 3-10.—Root penetration and joint penetration of welds.

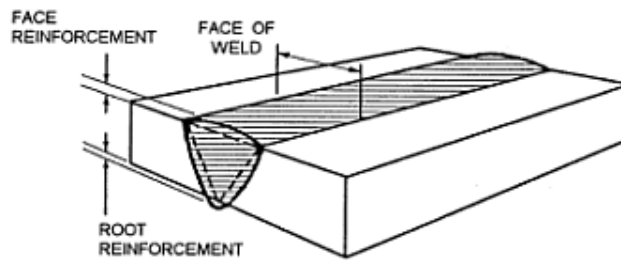

Figure 3-11.—Weld reinforcement.

TYPES OF WELDS

There are many types of welds. Some of the common types you will work with are the bead, groove, fillet, surfacing, tack, plug, slot, and resistance.

As a beginner, the first type of weld that you learn to produce is called a weld bead (referred to simply as a bead). A weld bead is a weld deposit produced by a single pass with one of the welding processes. An ex-ample of a weld bead is shown in figure 3-12. A weld bead may be either narrow or wide, depending on the amount of transverse oscillation (side-to-side move-ment) used by the welder. When there is a great deal of oscillation, the bead is wide; when there is little or no oscillation, the bead is narrow. A weld bead made with-out much weaving motion is often referred to as a stringer bead. On the other hand, a weld bead made with side-to-side oscillation is called a weave bead.

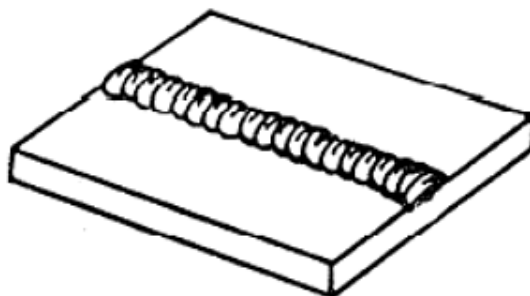

Figure 3-12.—Simple weld bead.

Groove welds are simply welds made in the groove between two members to be joined. The weld is adapt-able to a variety of butt joints, as shown in figure 3-13. Groove welds may be joined with one or more weld beads, depending on the thickness of the metal. If two or more beads are deposited in the groove, the weld is made with multiple-pass layers, as shown in figure 3-14. As a rule, a multiple-pass layer is made with stringer beads in manual operations. As a welder, you will use groove welds frequently in your work

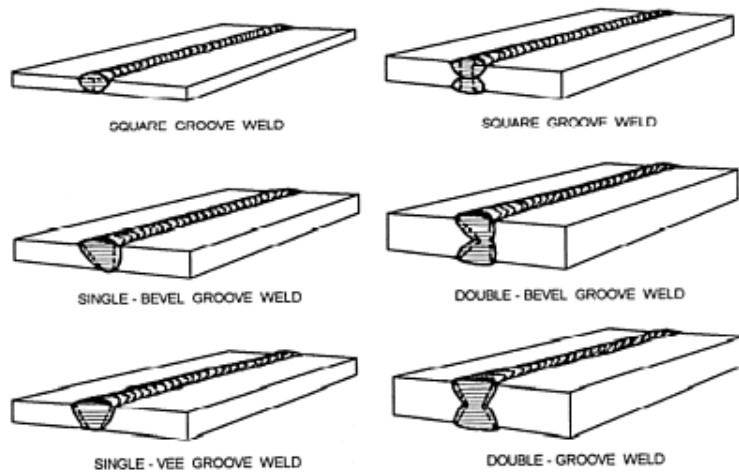

Figure 3-13.—Standard groove welds.

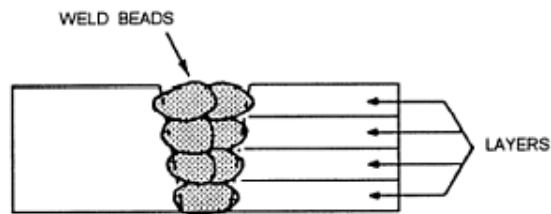

Figure 3-14.—Multiple-pass layers.

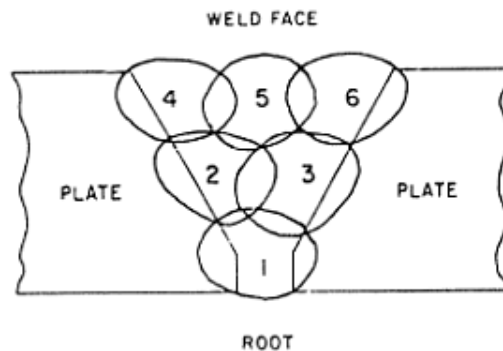

Figure 3-15.—Weld layer sequence.

Another term you should be familiar with, when making a multiple-pass weld, is the buildup sequence, as shown in figure 3-15. **Buildup sequence** refers to the order in which the beads of a multiple-pass weld are deposited in the joint.

NOTE

Often welding instructions specify an interpass temperature. The interpass temperature refers to the temperature below which the previously deposited weld metal must be before the next pass may be started.

After the effects of heat on metal are discussed, later in the chapter, you will understand the significance of the buildup sequence and the importance of controlling the interpass temperature.

Across-sectional view of a fillet weld (fig. 3-16) is triangular in shape. This weld is used to join two

sur-faces that are at approximately right angles to each other in a lap, tee, or comer joint.

3-16

Surfacing is a welding process used to apply a hard, wear-resistant layer of metal to surfaces or edges of worn-out parts. It is one of the most economical methods of conserving and extending the life of machines, tools, and construction equipment. As you can see in figure 3-17, a surfacing weld is composed of one or more stringer or weave beads. Surfacing, sometimes known as hardfacing or wearfacing, is often used to build up worn shafts, gears, or cutting edges. You will learn more about this type of welding in chapter 6 of this training manual.

3-17

A **tack weld** is a weld made to hold parts of an assembly in proper alignment temporarily until the final welds are made. Although the sizes of tack welds are not specified, they are normally between 1/2 inch to 3/4 inch in length, but never more than 1 inch in length. In determining the size and number of tack welds for a specific job, you should consider thicknesses of the metals being joined and the complexity of the object being assembled.

Plug and slot welds (fig. 3-18) are welds made through holes or slots in one member of a lap joint. These welds are used to join that member to the surface of another member that has been exposed through the hole. The hole may or may not be completely filled with weld metal. These types of welds are often used to join face-hardened plates from the backer soft side, to install liner metals inside tanks, or to fill up holes in a plate.

3-18

Resistance welding is a metal fabricating process in which the fusing temperature is generated at the joint by the resistance to the flow of an electrical current. This is accomplished by clamping two or more sheets of metal between copper electrodes and then passing an electrical current through them. When the metals are heated to a melting temperature, forging pressure is applied through either a manual or automatic means to weld the pieces together. Spot and seam welding (fig. 3-19) are two common types of resistance welding processes.

3-19

Spot welding is probably the most commonly used type of resistance welding. The material to be joined is placed between two electrodes and pressure is applied. Next, a charge of electricity is sent from one electrode through the material to the other electrode. Spot welding is especially useful in fabricating sheet metal parts.

Seam welding is like spot welding except that the spots overlap each other, making a continuous weld seam. In this process, the metal pieces pass between roller type of electrodes. As the electrodes revolve, the current is automatically turned on and off at the speed at which the parts are set to move. Seam welding is almost exclusively used in industrial manufacturing.

PARTS OF WELDS

For you to produce welds that meet the job requirements, it is important that you become familiar with the terms used to describe a weld. Figure 3-20 shows a groove weld and a fillet weld. 'he face is the exposed surface of a weld on the side from which the weld was made. The toe is the junction between the face of the weld and the base metal. The root of a weld includes the points at which the back of the weld intersects the base metal surfaces. When we look at a triangular cross section of a fillet weld, as shown in view B, the leg is the portion of the weld from the toe to the root. The throat is the distance from the root to a point on the face of the weld along a line perpendicular to the face of the weld. Theoretically, the face forms a straight line between the toes.

3-20

NOTE

The terms leg and throat apply only to fillet welds.

In determining the size of a groove weld (fig. 3-20, view A), such factors as the depth of the groove, root opening, and groove angle must be taken into consideration. The size of a fillet weld (view B) refers to the length of the legs of the weld. The two legs are assumed to be equal in size unless otherwise specified.

A gauge used for determining the size of a weld is known as a welding micrometer. Figure 3-21 shows how the welding micrometer is used to determine the various dimensions of a weld.

3-21

Some other terms you should be familiar with are used to describe areas or zones of welds. As we discussed earlier in the chapter, fusion is the melting together of base and/or filler metal. The fusion zone, as shown in figure 3-22, is the region of the base metal that is actually melted. The depth of fusion is the distance that fusion extends into the base metal or previous welding pass.

3-22

Another zone of interest to the welder is the heat-affected zone, as shown in figure 3-22. This zone includes that portion of the base metal that has not been melted; however, the structural or mechanical properties of the metal have been altered by the welding heat. Because the mechanical properties of the base metal are affected by the welding heat, it is important that you learn techniques to control the heat input. One technique often used to minimize heat input is the intermittent weld. We discuss this and other techniques as we progress through this chapter; but, first we will discuss some of the considerations that affect the welded joint design.

Welded Joint Design

The details of a joint, which includes both the geometry and the required dimensions, are called the joint design. Just what type of joint design is best suited for a particular job depends on many factors. Although welded joints are designed primarily to meet strength and safety requirements, there are other factors that must be considered. A few of these factors areas follows:

Whether the load will be in tension or compression and whether bending, fatigue, or impact stresses will be applied

- How a load will be applied; that is, whether the load will be steady, sudden, or variable
- The direction of the load as applied to the joint
- The cost of preparing the joint

Another consideration that must be made is the ratio of the strength of the joint compared to the strength of the base metal. This ratio is called joint efficiency. An efficient joint is one that is just as strong as the base metal.

Normally, the joint design is determined by a designer or engineer and is included in the project plans and specifications. Even so, understanding the joint design for a weld enables you to produce better welds.

Earlier in this chapter, we discussed the five basic types of welded joints—butt, corner, tee, lap, and edge. While there are many variations, every joint you weld will be one of these basic types. Now, we will consider some of the variations of the welded joint designs and the efficiency of the joints.

BUTT JOINTS

The square butt joint is used primarily for metals that are 3/16 inch or less in thickness. The joint is reasonably strong, but its use is not recommended when the metals are subject to fatigue or impact loads. Preparation of the joint is simple, since it only requires matching the edges of the plates together; however, as with any other joint, it is important that it is fitted together correctly for the entire length of the joint. It is also important that you allow enough root opening for the joint. Figure 3-23 shows an example of this type of joint.

When you are welding metals greater than 3/16 inch in thickness, it is often necessary to use a grooved butt joint. The purpose of grooving is to give the joint the required strength. When you are using a grooved joint, it is important that the groove angle is sufficient to allow the electrode into the joint; otherwise, the weld will lack penetration and may crack. However, you also should avoid excess beveling because this wastes both weld metal and time. Depending on the thickness of the base metal, the joint is either single-grooved (grooved on one side only) or double-grooved (grooved on both sides). As a welder, you primarily use the single-V and double-V grooved joints.

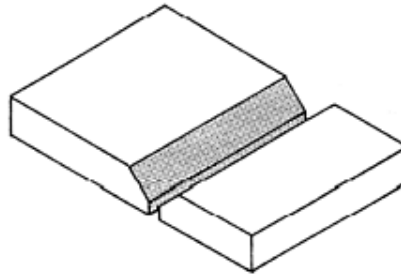

Figure 3-23.—Butt joints.

The single-V butt joint (fig. 3-23, view B) is for use on plates 1/4 inch through 3/4 inch in thickness. Each member should be beveled so the included angle for the joint is approximately 60 degrees for plate and 75 degrees for pipe. Preparation of the joint requires a special beveling machine (or cutting torch), which makes it more costly than a square butt joint. It also requires more filler material than the square joint; however, the joint is stronger than the square butt joint. But, as with the square joint, it is not recommended when subjected to bending at the root of the weld.

The double-V butt joint (fig. 3-23, view C) is an excellent joint for all load conditions. Its primary use is on metals thicker than 3/4 inch but can be used on thinner plate where strength is critical. Compared to the single-V joint, preparation time is greater, but you use less filler metal because of the narrower included angle. Because of the heat produced by welding, you should alternate weld deposits, welding first on one side and then on the other side. This practice produces a more symmetrical weld and minimizes warpage.

Remember, to produce good quality welds using the groove joint, you should ensure the fit-up is consistent for the entire length of the joint, use the correct groove angle, use the correct root opening, and use the correct root face for the joint. When you follow these principles, you produce better welds every time. Other standard grooved butt joint designs include the bevel groove, J-groove, and U-groove, as shown in figure 3-24.

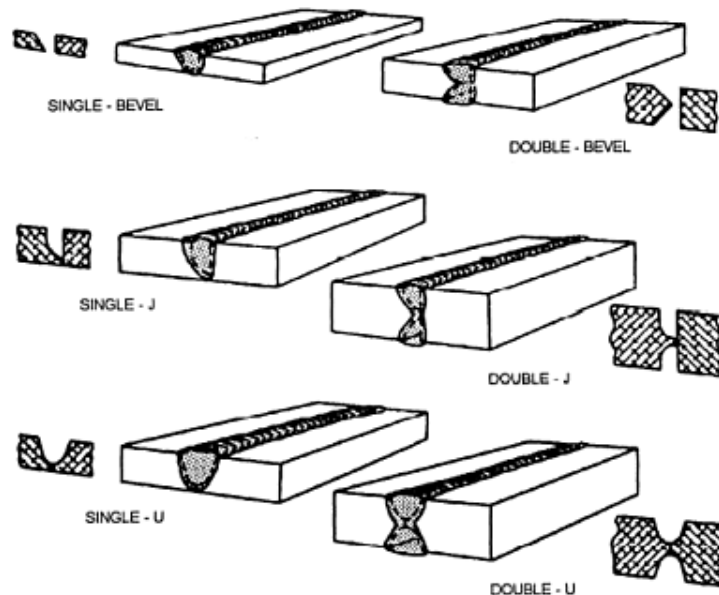

Figure 3-24.—Additional types of groove welds.

CORNER JOINTS

The flush corner joint (fig. 3-25, view A) is designed primarily for welding sheet metal that is 12 gauge or thinner. It is restricted to lighter materials, because deep penetration is sometimes difficult and the design can support only moderate loads.

The half-open corner joint (fig. 3-25, view B) is used for welding materials heavier than 12 gauge. Penetration is better than in the flush corner joint, but its use is only recommended for moderate loads.

The full-open corner joint (fig. 3-25, view C) produces a strong joint, especially when welded on both sides. It is useful for welding plates of all thicknesses.

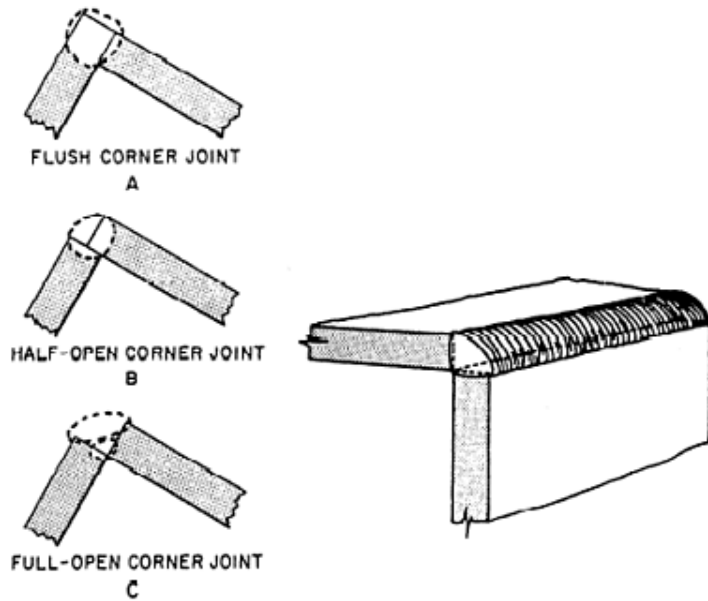

Figure 3-25.—Corner joints.

TEE JOINTS

The **square tee joint** (fig. 3-26, view A) requires a fillet weld that can be made on one or both sides. It can be used for light or fairly thick materials. For maximum strength, considerable weld metal should be placed on each side of the vertical plate.

The **single-bevel tee joint** (fig. 3-26, view B) can withstand more severe loadings than the square tee joint, because of better distribution of stresses. It is generally used on plates of 1/2 inch or less in thickness and where welding can only be done from one side.

The **double-bevel tee joint** (fig. 3-26, view C) is for use where heavy loads are applied and the welding can be done on both sides of the vertical plate.

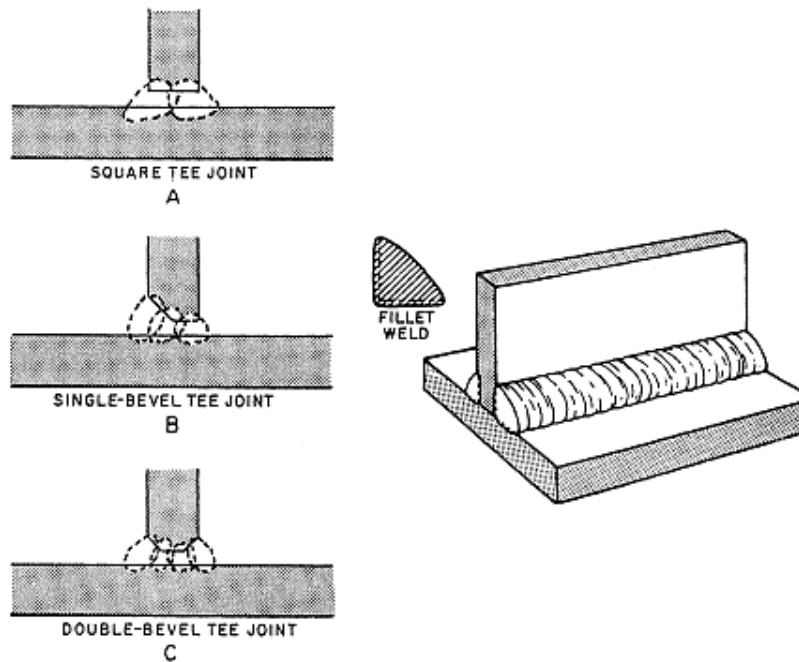

Figure 3-26.—T ee joints.

LAP JOINTS

The single-fillet lap joint (fig. 3-27, view A) is easy to weld, since the filler metal is simply deposited along the seam. The strength of the weld depends on the size of the fillet. Metal up to 1/2 inch in thickness and not subject to heavy loads can be welded using this joint.

When the joint will be subjected to heavy loads, you should use the double-fillet lap joint (fig. 3-27, view B). When welded properly, the strength of this joint is very close to the strength of the base metal.

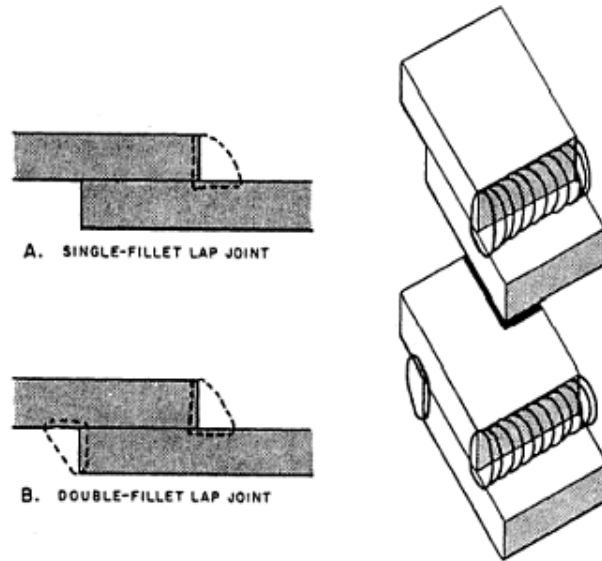

Figure 3-27.—Lap joints,

EDGE JOINTS

The flanged edge joint (fig. 3-28, view A) is suitable for plate 1/4 inch or less in thickness and can only sustain light loads. Edge preparation for this joint may be done, as shown in either views B or C.

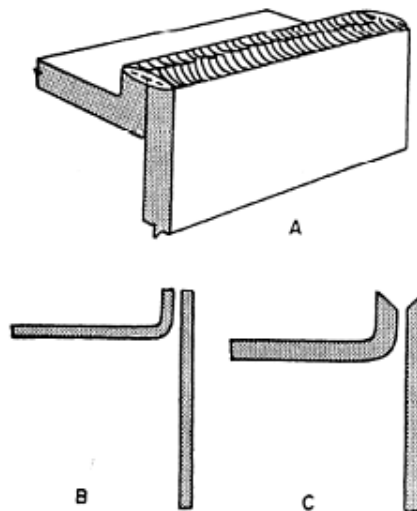

Figure 3-28.—Flanged edge joints.

Welding Positions

All welding is done in one of four positions:

1. Flat
2. Horizontal
3. Vertical
4. Overhead

Fillet or groove welds can be made in all of these positions. Figure 3-29 shows the various positions used in plate welding. The American Welding Society (AWS) identifies these positions by a number/letter designation; for instance, the 1G position refers to a groove weld that is to be made in the flat position. Here the 1 is used to indicate the flat position and the G indicates a

groove weld. For a fillet weld made in the flat position, the number/letter designation is 1F (F for fillet). These number/letter designations refer to test positions. These are positions a welder would be required to use during a welding qualification test. As a welder, there is a good possibility that someday you will be required to certify or perform a welding qualification test; therefore, it is important that you have a good understanding and can apply the techniques for welding in each of the test positions.

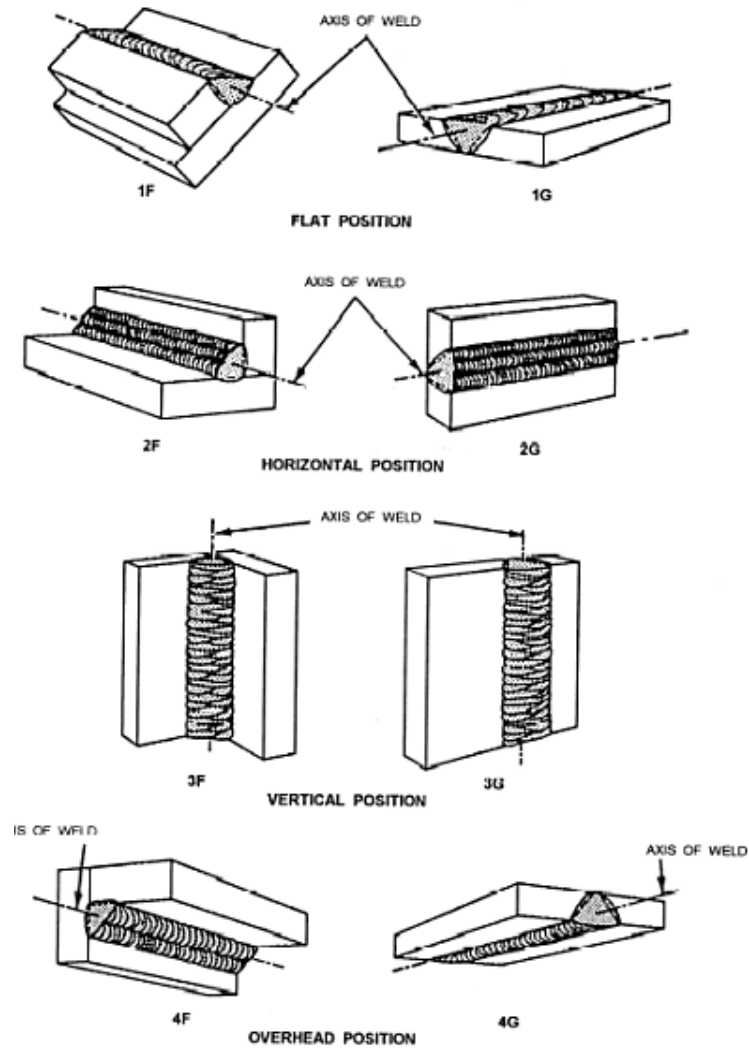

Figure 3-29.—Welding positions—plate.

Because of gravity, the position in which you are welding affects the flow of molten filler metal. Use the flat position, if at all possible, because gravity draws the molten metal downward into the joint making the welding faster and easier. Horizontal welding is a little more difficult, because the molten metal tends to sag or flow downhill onto the lower plate. Vertical welding is done in a vertical line, usually from bottom to top; however, on thin material downhill or downhand welding may be easier. The overhead position is the most difficult position. Because the weld metal flows downward, this position requires considerable practice on your part to produce good quality welds.

Although the terms flat, horizontal, vertical, and overhead sufficiently describe the positions for plate welding, they do not adequately describe pipe welding positions. In pipe welding, there are four basic test positions used (fig. 3-30). Notice that the position refers to the position of the pipe, not the position of welding.

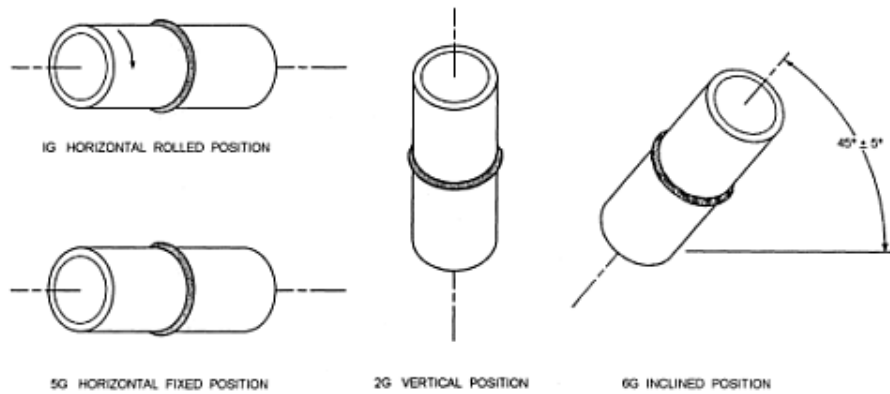

Figure 3-30.—Welding position-pipe.

Test position 1G is made with the pipe in the horizontal position. In this position, the pipe is rolled so that the welding is done in the flat position with the pipe rotating under the arc. This position is the most advantageous of all the pipe welding positions. When you are welding in the 2G position, the pipe is placed in the vertical position so the welding can be done in the horizontal position. The 5G position is similar to the 1G position in that the axis of the pipe is horizontal. But, when you are using the 5G position, the pipe is not turned or rolled during the welding operation; therefore, the welding is more difficult in this position. When you are using the 6G position for pipe welding, the axis of the pipe is at a 45-degree angle with the horizontal and the pipe is not rolled. Since the pipe is not rolled, welding has to be done in all the positions— flat, vertical, horizontal, and overhead. If you can weld pipe in this position, you can handle all the other welding positions.

NOTE

There is no 3G or 4G test position in pipe welding. Also, since most pipe welds are groove welds, they are identified by the letter G

We will discuss more about the techniques used for welding in the various positions later in this course, but for now, let's talk about the effects of heat on metal.

Expansion and Contraction

When a piece of metal is heated, the metal expands. Upon cooling, the metal contracts and tries to resume its original shape. The effects of this expansion and contraction are shown in figure 3-31. View A shows a bar that is not restricted in any way. When the bar is heated, it is free to expand in all directions. If the bar is allowed to cool without restraint, it contracts to its original dimensions.

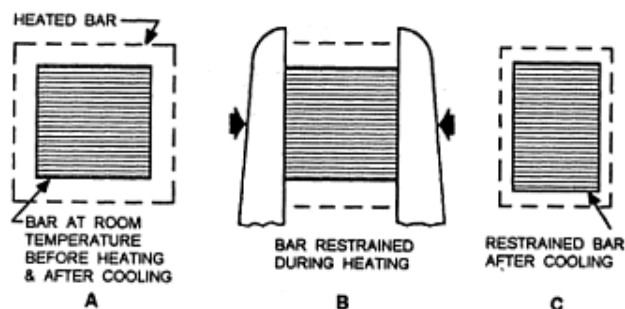

Figure 3-31.—Effects of expansion and contraction.

When the bar is clamped in a vise (view B) and heated, expansion is limited to the unrestricted sides of the bar. As the bar begins to cool, it still contracts uniformly in all directions. As a result, the bar is now deformed. It has become narrower and thicker, as shown in view C.

These same expansion and contraction forces act on the weld metal and base metal of a welded joint; however, when two pieces of metal are welded together, expansion and contraction may not be uniform throughout all parts of the metal. This is due to the difference in the temperature from the actual weld joint out to the edges of the joint. This difference in temperature leads to internal stresses, distortion, and warpage. Figure 3-32 shows some of the most common difficulties that you are likely to encounter.

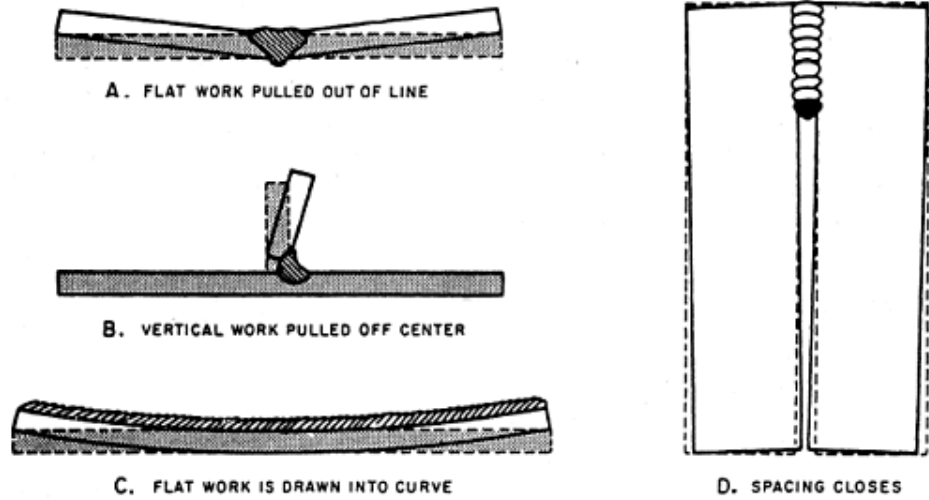

Figure 3-32.—Distortion caused by welding.

When you are welding a single-V butt joint (fig.3-32, view A), the highest temperature is at the surface of the molten puddle. The temperature decreases as you move toward the root of the weld and away from the weld. Because of the high temperature of the molten metal, this is where expansion and contraction are greatest. When the weld begins to cool, the surface of the weld joint contracts (or shrinks) the most, thus causing warpage or distortion. View B shows how the same principles apply to a tee joint. Views C and D show the distortions caused by welding a bead on one side of a plate and welding two plates together without proper tack welds.

All metals, when exposed to heat buildup during welding, expand in the direction of least resistance. Conversely, when the metal cools, it contracts by the same amount; therefore, if you want to prevent or reduce the distortion of the weldment, you have to use some method to overcome the effects of heating and cooling.

CONTROLLING DISTORTION

You can control the distortion caused by expansion and contraction during welding by following the simple procedures listed here.

Proper Edge Preparation and Fit-up

As discussed earlier in this chapter, proper edge preparation and fit-up are essential to good quality welds. By making certain the edges are properly beveled and spacing is adequate, you can restrict the effects of distortion. Additionally, you should use tack welds, especially on long joints. Tack welds should be spaced at least 12 inches apart and run approximately twice as long as the thickness of the weld.

Control the Heat Input

You should understand that the faster a weld is made, the less heat is absorbed by the base metal. As you gain welding experience, it will become easier for you to weld a seam with the minimum amount of heat by simply speeding up the welding process.

Regardless of your experience, it is often necessary to use a welding technique designed to control heat input. An intermittent weld (sometimes called a skip weld) is often used instead of one continuous weld. When you are using an intermittent weld, a short weld is made at the beginning of the joint. Next, you skip to the center of the seam and weld a few inches. Then, you weld at the other end of the joint. Finally, you return to the end of the first weld and repeat the cycle until the weld is finished. Figure 3-33 shows the intermittent weld.

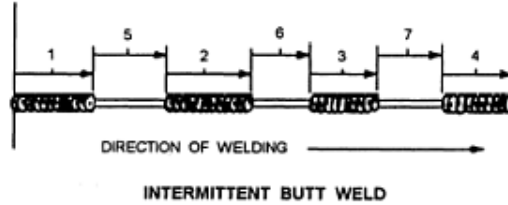
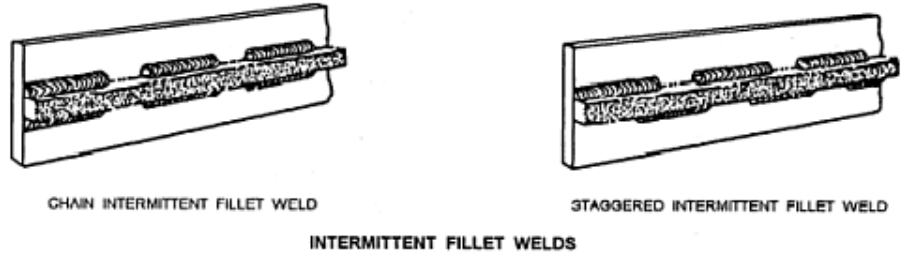

Figure 3-33.—Intermittent welds.

Another technique to control the heat input is the back-step method (fig. 3-34). When using this technique, you deposit short weld beads from right to left along the seam.

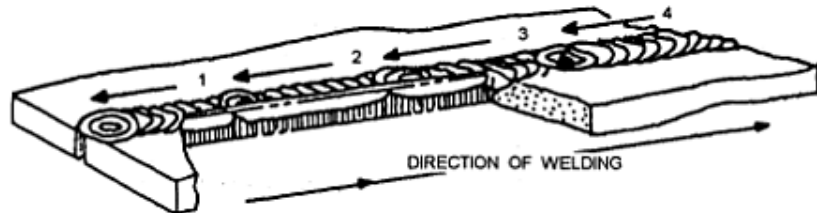

Figure 3-34.—Back-step welding.

Preheat the Metal

As discussed earlier, expansion and contraction rates are not uniform in a structure during welding due to the differences in temperature throughout the metal. To control the forces of expansion and contraction, you preheat the entire structure before welding. After the welding is complete, you allow the structure to cool slowly. More about preheating and postheating is discussed later in this training course.

Limit the Number of Weld Passes

You can keep distortion to a minimum by using as few weld passes as possible. You should limit the number of weld passes to the number necessary to meet the requirements of the job. (See fig. 3-35.)

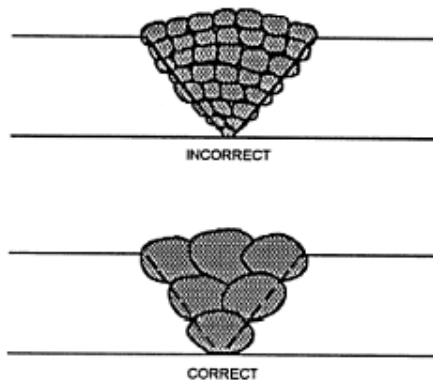

Figure 3-35.—Weld passes.

Use Jigs and Fixtures

Since holding the metal in a fixed position prevents excessive movements, the use of jigs and fixtures can help prevent distortion. A jig or fixture is simply a device used to hold the metal rigidly in position during the welding operation.

Allow for Distortion

A simple remedy for the distortion caused by expansion and contraction is to allow for it during fit-up. To reduce distortion, you angle the parts to be welded slightly in the opposite direction in which the contraction takes place. When the metal cools, contraction forces pull the pieces back into position. Figure 3-36 shows how distortion can be overcome in both the butt and tee joints.

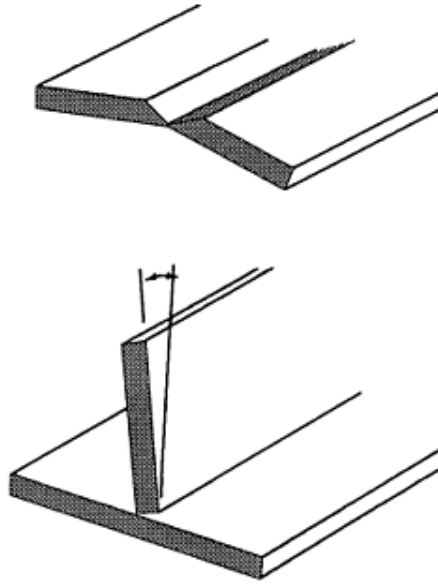

Figure 3-36.—Allowing for distortion.

There is more to being a good welder than just being able to lay a good bead. There are many factors that must be considered. Later, we discuss additional techniques that you can apply to specific welding situations.

Welding Procedures

There are many factors involved in the preparation of any welded joint. The detailed methods and practices used to prepare a particular weldment are called the welding procedure. A welding procedure identifies all the welding variables pertinent to a particular job or project. Generally, these variables include the welding process, type of base metal, joint design, welding position, type of shielding, preheating and postheating requirements, welding machine setting, and testing requirements.

Welding procedures are used to produce welds that will meet the requirements of commonly used codes. The American Welding Society (AWS) produces the Structural Welding Code that is used for the design and construction of steel structures. Another code that is used for the construction of steam boilers and pressure vessels is published by the American Society of Mechanical Engineers (ASME). These codes provide a standardized guide of proven welding practices and procedures.

While you are probably not directly responsible for developing welding procedures, you could be assigned to a welding job that requires you to follow them. For example, when a job is assigned, it is accompanied by a set of drawings and specifications. When there is welding required for the job, the specifications normally require it to be accomplished according to a specific code requirement. The unit is then responsible for ensuring that the welders assigned to the job are qualified to produce the welds according to this welding procedure specification.

Using the Structural Welding Code, along with the project drawings and specifications, the welding inspector develops a welding procedure specification that meets the requirements of the job. The importance of this document is that it assures that each of the variables can be repeated by qualified welders.

Once a welding procedure specification has been developed and qualified, welders are then required to perform a Welding Performance Qualification test. After the test is complete, the weld specimens are tested according to the requirements of the Welding Procedure Specification. You may use either destructive or nondestructive tests. One example of a destructive test is the guided-bend test. An X-ray test is considered nondestructive. Testing is discussed in greater detail later in this course.

NOTE

When you are assigned to do a welding job, make a thorough examination of the drawings and specifications.

Look carefully at the notes on the drawings and Section 5 (metals) of the specifications. If specific codes are cited, inform the project supervisor so that you can receive the training needed to perform the required welds.

Drawings

Drawings or sketches are used to convey the ideas of an engineer to the skilled craftsman working in the shop. As a welder, you must be able to work from a drawing in order to fabricate metal parts exactly as the engineer has designed them.

READING DRAWINGS

To read a drawing, you must know how engineers use lines, dimensions, and notes to communicate their ideas on paper. In this section, we briefly discuss each of these drawing elements.

Lines

Figure 3-38 shows many of the different types of lines that are used in drawings. You can see that each line has a specific meaning you must understand to interpret a drawing correctly. Let's discuss a few of the most important types. A visible line (sometimes called object line) is used to show the edges of an object that are visible to the viewer. For example, if you look at one of the walls of the room you are in, you can see the outline of the walls and (depending on the wall you are looking at) the outline of doors and windows. On a drawing, these visible outlines or edges can be shown using visible lines that are drawn as described in figure 3-38.

LINE STANDARDS							
NAME	CONVENTION	DESCRIPTION AND APPLICATION	EXAMPLE	NAME	CONVENTION	DESCRIPTION AND APPLICATION	EXAMPLE
VISIBLE LINES		HEAVY UNBROKEN LINES USED TO INDICATE VISIBLE EDGES OF AN OBJECT		LEADER		THIN LINE TERMINATED WITH ARROW-HEAD OR DOT AT ONE END USED TO INDICATE A PART, DIMENSION OR OTHER REFERENCE	
				PHANTOM OR DATUM LINE		MEDIUM SERIES OF ONE LONG DASH AND TWO SHORT DASHES EVENLY SPACED ENDING WITH LONG DASH USED TO INDICATE ALTERNATE POSITION OF PARTS, REPEATED DETAIL OR TO INDICATE A DATUM PLANE	
HIDDEN LINES		MEDIUM LINES WITH SHORT EVENLY SPACED DASHES USED TO INDICATE CONCEALED EDGES		STITCH LINE		MEDIUM LINE OF SHORT DASHES EVENLY SPACED AND LABELED USED TO INDICATE STITCHING OR SEWING	
				CENTER LINES		THIN LINES MADE UP OF LONG AND SHORT DASHES ALTERNATELY SPACED AND CONSISTENT IN LENGTH USED TO INDICATE SYMMETRY ABOUT AN AXIS AND LOCATION OF CENTERS	
DIMENSION LINES		THIN LINES TERMINATED WITH ARROW HEADS AT EACH END USED TO INDICATE DISTANCE MEASURED		BREAK (LONG)		THIN SOLID RULED LINES WITH FREEHAND ZIG-ZAGS USED TO REDUCE SIZE OF DRAWING REQUIRED TO DELINEATE OBJECT AND REDUCE DETAIL	
				BREAK (SHORT)		THICK SOLID FREE HAND LINES USED TO INDICATE A SHORT BREAK	
				CUTTING OR VIEWING PLANE VIEWING PLANE OPTIONAL		THICK SOLID LINES WITH ARROWHEAD TO INDICATE DIRECTION IN WHICH SECTION OR PLANE IS VIEWED OR TAKEN	
EXTENSION LINES		THIN UNBROKEN LINES USED TO INDICATE EXTENT OF DIMENSIONS		CUTTING PLANE FOR COMPLEX OR OFFSET VIEWS		THICK SHORT DASHES USED TO SHOW OFFSET WITH ARROW-HEADS TO SHOW DIRECTION VIEWED	

Figure 3-38.—Line characters and uses.

Now look at the wall again. Assuming that the wall is wood frame, you know that there are studs or framing members inside the wall that you cannot see. Also, the wall may contain other items, such as water pipes and electrical conduit, that you also cannot see. On a drawing, the edges of those concealed studs and other items can be shown using hidden lines (fig.3-38). These lines are commonly used in drawings. As you can imagine, the more hidden lines there are, the more difficult it becomes to decipher what is what; however, there is another way these studs and other items can be “seen.” Imagine that you “cut away” the wallboard that covers the wall and replace it with a sheet of clear plastic. That clear plastic can be thought of as a cutting or viewing plane (fig.3-38) through which the previously concealed studs, piping, and conduit are now visible. Now those items can be drawn using visible lines, rather than hidden lines. A view of this type is called a sectional view, and a drawing of the view is called a section drawing. Section drawings are commonly used to show the internal components of a complicated object.

Many times, you will see lines drawn on the visible surfaces of a section drawing. These lines, called section lines, are used to show different types of materials. Some of the types of section lines you are likely to encounter as a welder are shown in figure 3-39.

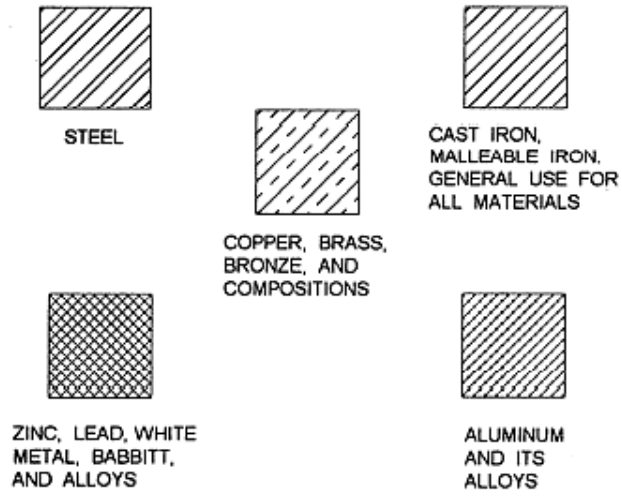

Figure 3-39.—Section lines for various metals.

Another use of lines is to form symbols, such as welding symbols, that are discussed later in this lesson.

Dimensions

While engineers use lines to describe the shape or form of an object, they use dimensions to provide a complete size description. Dimensions used on drawing

are of two types: size and location. As implied by their names, a size dimension shows the size of an object or parts of an object and a location dimension is used to describe the location of features. Examples of both size and location dimensions are shown in figure 3-40.

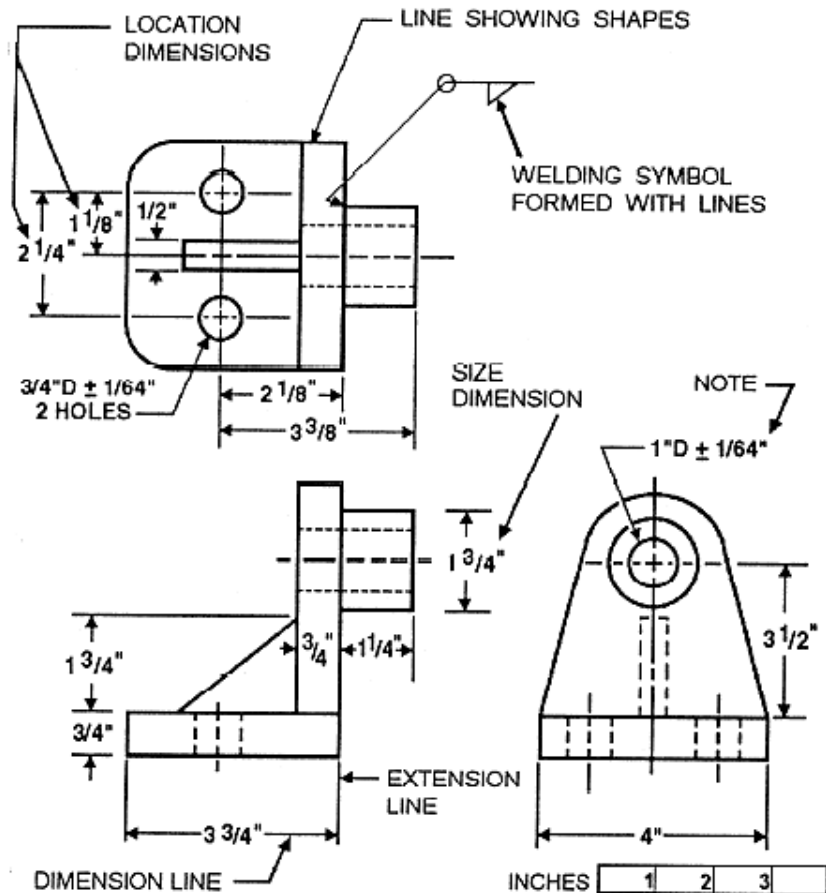

Figure 3-40.—Elements of an orthographic drawing.

While on the subject of dimensions, it should be noted that large objects are seldom drawn to their true size. Instead, the engineer or draftsman reduces the size of the object "to scale." For example, when drawing a 40-foot tower, the drawing may be prepared using a scale of 1/2"= 1'-0". In this case, the height of the tower, on paper, is 20 inches. The scale used to prepare working

drawings is always noted on the drawing. It maybe a fractional scale, such as discussed here, or a graphic scale, such as the one shown in figure 3-40. Often both numerical and graphic scales are usually shown on construction drawings.

When you are using a drawing, the dimensions of an object should never be measured (scaled) directly from the drawing. These measurements are frequently inaccurate, since a change in atmospheric conditions causes drawing paper to shrink or expand. To ensure accuracy, always use the size and location dimensions shown on the drawing. If a needed dimension is not shown on the drawing, you should check the graphic scale, since it will always shrink or expand at the same rate as the drawing paper.

Notes

Drawing notes are used for different purposes and are either general or specific in nature. One example of how notes are used are the two notes shown in figure 3-40 that give the inside diameters of the holes. As you can see, these notes are used for size dimensioning. They are specific notes in that, by using a leader line, each note is referred to a specific hole or set of holes.

A general note is used to provide additional information that does not apply to any one particular part or feature of the drawing. For example, the drawing shown in figure 3-40 could contain a general note saying: "All holes shall be reamed using a tolerance of $\pm 1/64$ inch."

Drawing Views

Look at the drawing shown in figure 3-41. This type of drawing is called a pictorial drawing. These drawing

s are frequently used to show how an object should appear after it is manufactured. Pictorial drawings are used as working drawings for a simple item, such as a metal washer. For a more complex object, as shown in figure 3-41, it becomes too difficult to provide a complete description in a pictorial drawing. In this case, it is common practice to prepare orthographic drawings to describe the object fully.

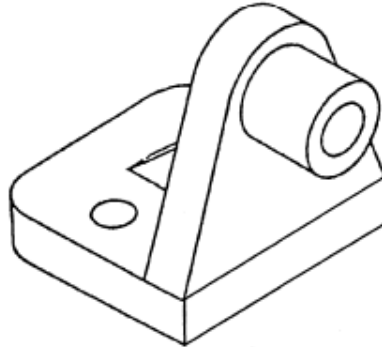

Figure 3-41.—Pictorial drawing of a steel part.

Assume you are holding the object shown in figure 3-41 in your hands. When you hold the object so you are looking directly at the top face of the object, the view you see is the top view. A drawing of that view is called an orthographic drawing.

Obviously, an orthographic drawing of only the top view of the object is insufficient to describe the entire object; therefore, additional orthographic drawings of one or more of the other faces of the object are necessary. The number of orthographic views needed to describe an object fully depends upon the complexity of the object. For example, a simple metal washer can be fully described using only one orthographic view; however, an extremely complex object may require as many as six views (top, front, left side, right side, back, and bottom). Most objects, such as the steel part shown in figure 3-41, can be sufficiently described using three views: top, front, and right side. For the object shown in figure 3-41, orthographic drawings of the top, front, and right-side views are shown in figure 3-42.

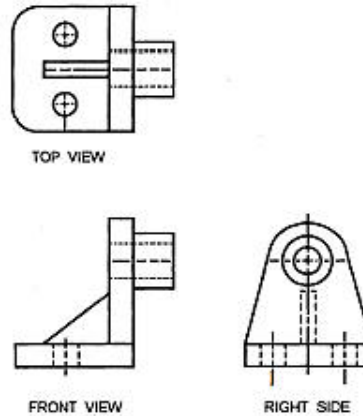

Figure 3-42.—Three-view orthographic drawing of the steel part shown in figure 3-41.

Notice the placement of the views shown in figure 3-42. This is a standard practice that you should be aware of when reading orthographic drawings. By this standard practice, the top view is always placed above the front view and the right-side view is placed to the right of the front view. When additional views are needed, the left side is always drawn to the left of the front view and the bottom is drawn below the front view. Placement of the back view is somewhat flexible; however, it is usually drawn to the left of the left-side view. When reading and understanding the different orthographic views, you find it is sometimes helpful to prepare a pictorial sketch.

Think of drawings as a form of communication. They are intended to help you understand all the necessary information you need to fabricate and assemble an object regardless of the complexity. It is important that you learn to read drawings.

Handling and Care of Drawings

Special care should be exercised in the handling of drawings. When they are not being used, keep them on a rack or in another assigned place of storage. Drawings are valuable, and they may be difficult or impossible to replace if they are lost or damaged.

Now, we will discuss some special symbols. These are symbols a welder must be able to read and to understand how they are used to convey information.

WELDING SYMBOLS

Special symbols are used on a drawing to specify where welds are to be located, the type of joint to be used, as well as the size and amount of weld metal to be deposited in the joint. These symbols have been standardized by the American Welding Society (AWS). You will come into contact with these symbols anytime you do a welding job from a set of blueprints. You need to have a working knowledge of the basic weld symbols and the standard location of all the elements of a welding symbol.

A standard welding symbol (fig. 3-43) consists of a reference line, an arrow, and a tail. The reference line becomes the foundation of the welding symbol. It is used to apply weld symbols, dimensions, and other data to the weld. The arrow simply connects the reference line to the joint or area to be welded. The direction of the arrow has no bearing on the significance of the reference line. The tail of the welding symbol is used only when necessary to include a specification, process, or other reference information.

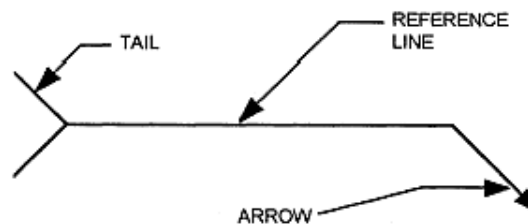

Figure 3-43.—Standard welding symbol.

Weld Symbols

The term weld symbol refers to the symbol for a specific type of weld. As discussed earlier, fillet, groove, surfacing, plug, and slot are all types of welds. Basic weld symbols are shown in figure 3-44. The weld symbol is only part of the information required in the welding symbol. The term welding symbol refers to the total symbol, which includes all information needed to specify the weld(s) required.

BASIC WELD SYMBOLS									
BEAD	FILLET	PLUG OR SLOT	GROOVE OR BUTT						
			SQUARE	V	BEVEL	U	J	FLARE V	FLARE BEVEL

Figure 3-44.—Basic weld symbols.

Figure 3-45 shows how a weld symbol is applied to the reference line. Notice that the vertical leg of the weld symbol is shown drawn to the left of the slanted leg. Regardless of whether the symbol is for a fillet, bevel, J-groove, or flare-bevel weld, the vertical leg is always drawn to the left.

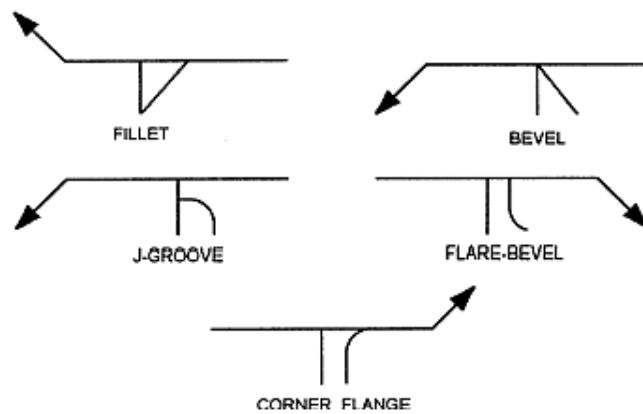

Figure 3-45.—Weld symbols applied to reference line.

Figure 3-46 shows the significance of the positions of the weld symbols position on the reference line. In view A the weld symbol is on the lower side of the reference line that is termed the arrow side. View B shows a weld symbol on the upper side of the reference line that is termed the other side. When weld symbols are placed on both sides of the reference line, welds must be made on both sides of the joint (view C).

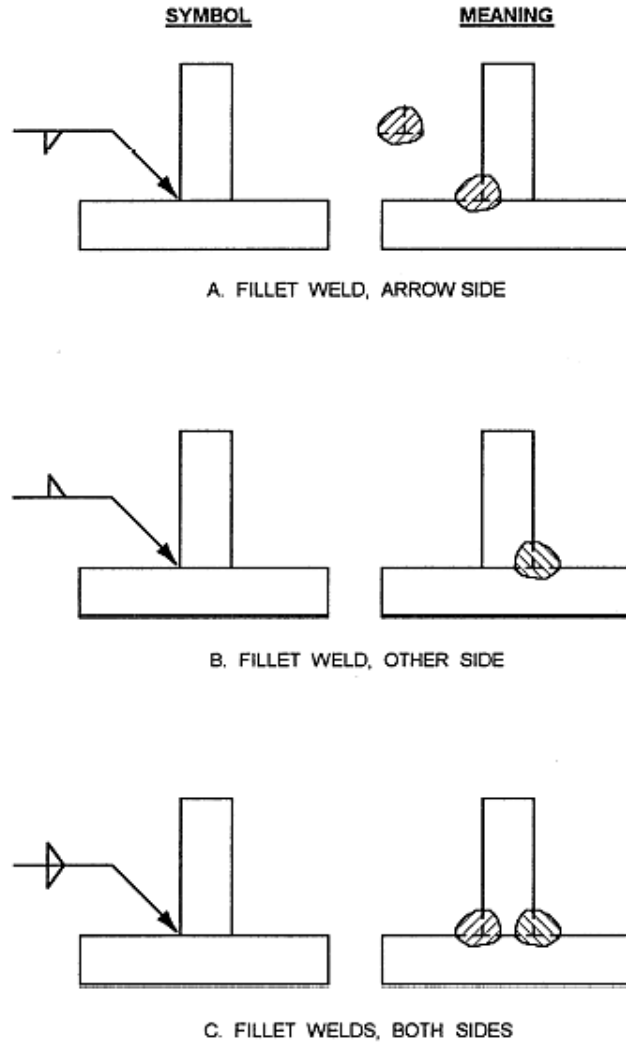

Figure 3-46.—Specifying weld locations.

When only one edge of a joint is to be beveled, it is necessary to show which member is to be beveled. When such a joint is specified, the arrow of the welding symbol points with a definite break toward the member to be beveled. This is shown in figure 3-47.

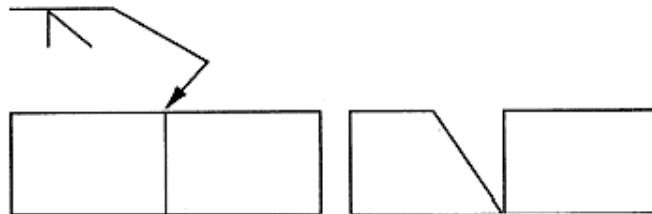

Figure 3-47.—Arrowhead indicates beveled plate.

Figure 3-48 shows other elements that may be added to a welding symbol. The information applied to the reference line on a welding symbol is read from left to right regardless of the direction of the arrow.

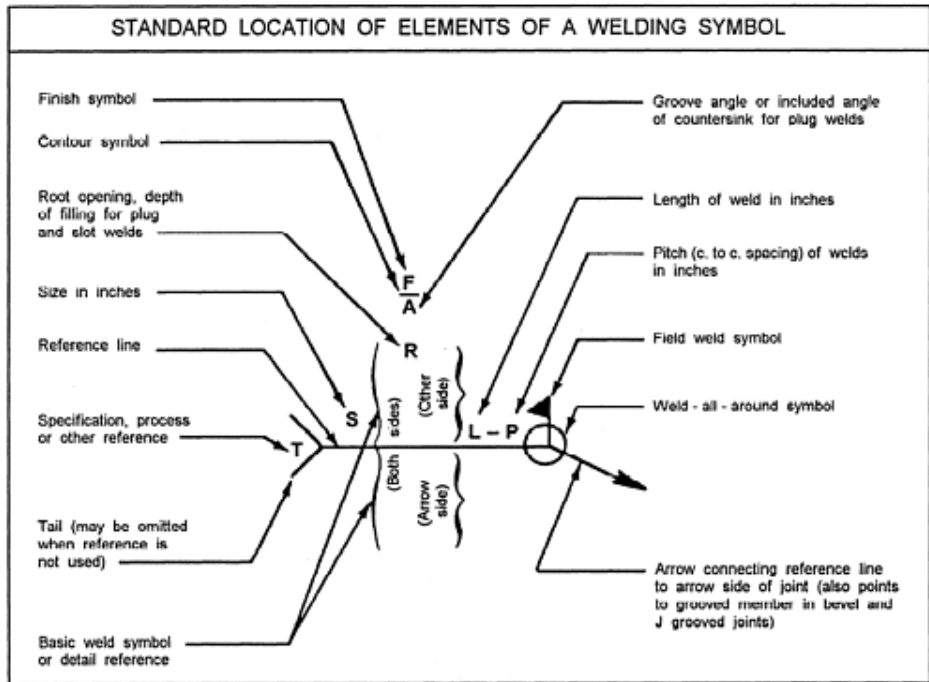

Figure 3-48.—Elements of a welding symbol.

Dimensioning

In figure 3-48, notice there are designated locations for the size, length, pitch (center-to-center spacing), groove angle, and root opening of a weld. These locations are determined by the side of the reference line on which the weld symbol is placed. Figure 3-49 shows how dimensions are applied to symbols.

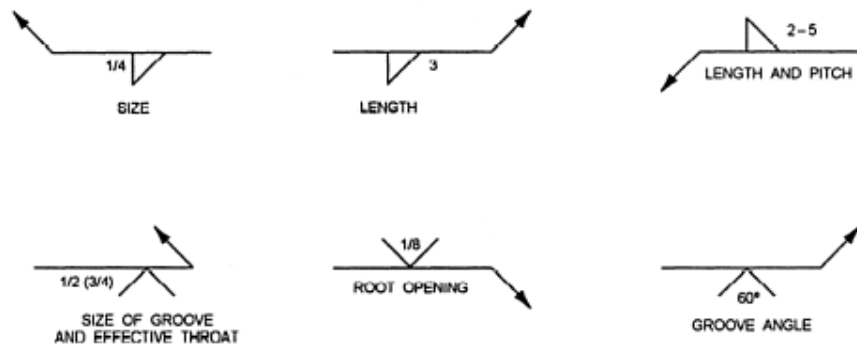

Figure 3-49.—Dimensions applied to weld symbols.

Figure 3-50 shows the meaning of various welding dimension symbols. Notice that the size of a weld is shown on the left side of the weld symbol (fig. 3-50, view A). The length and pitch of a fillet weld are indicated on the right side of the weld symbol. View B shows a tee joint with 2-inch intermittent fillet welds that are 5 inches apart, on center. The size of a groove weld is shown in view C. Both sides are 1/2 inch, but note that the 60-degree groove is on the other side of the joint and the 45-degree groove is on the arrow side.

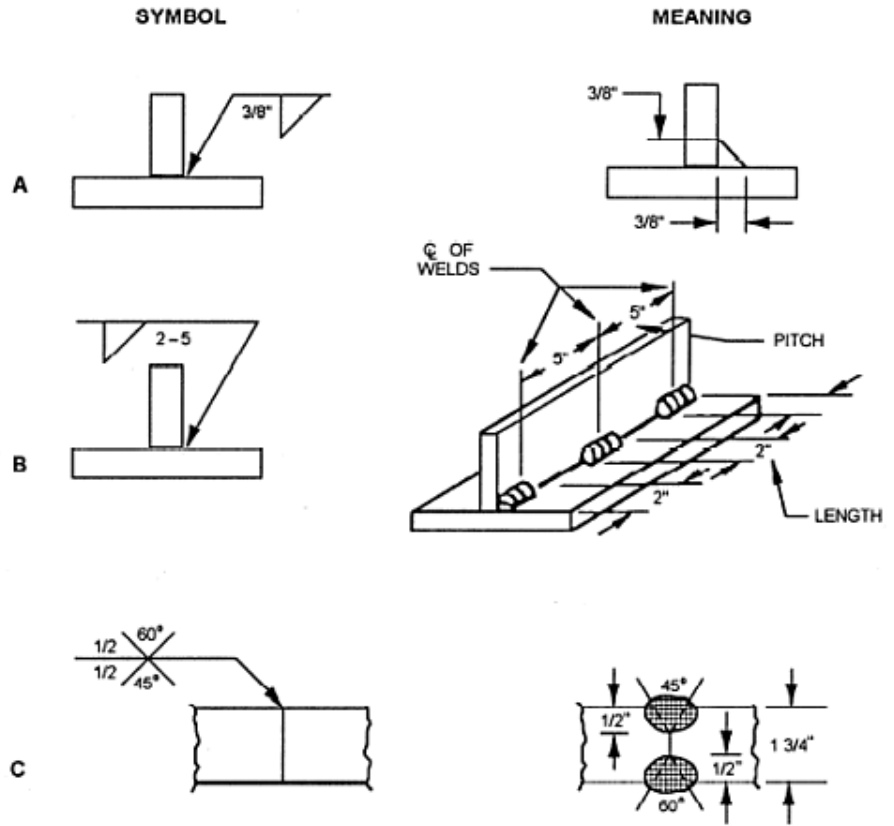

Figure 3-50.—Dimensioning of welds.

Supplementary Symbols

In addition to basic weld symbols, a set of supplementary symbols may be added to a welding symbol. Some of the most common supplementary symbols are shown in figure 3-51.

CONTOUR		
FLUSH	CONVEX	CONCAVE
WELD-ALL-AROUND	FIELD WELD	

Figure 3-51.—Supplementary symbols.

Contour symbols are used with weld symbols to show how the face of the weld is to be formed. In addition to contour symbols, finish symbols are used to indicate the method to use for forming the contour of the weld.

When a finish symbol is used, it shows the method of finish, not the degree of finish; for example, a C is used to indicate finish by chipping, an M means machining, and a G indicates grinding. Figure 3-52 shows how contour and finish symbols are applied to a welding symbol. This figure shows that the weld is to be ground flush. Also, notice that the symbols are placed on the same side of the reference line as the weld symbol.

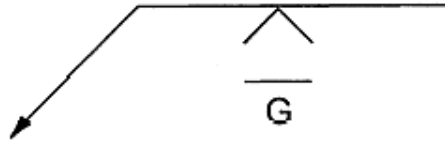

Figure 3-52.—Finish and contour symbols.

Another supplementary symbol shown in figure 3-51 is the weld-all-around symbol. When this symbol is placed on a welding symbol, welds are to continue all around the joint.

Welds that cannot be made in the shop are identified as field welds. A field weld symbol is shown in figure 3-51. This symbol is a black flag that points toward the tail of the welding symbol.

Specifying Additional Information

It is sometimes necessary to specify a certain welding process, a type of electrode, or some type of reference necessary to complete a weld. In this case, a note can be placed in the tail of the reference line. (See fig. 3-53.) If additional information is not needed, then the tail is omitted.

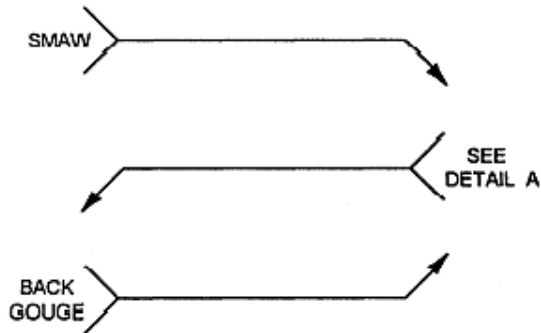

Figure 3-53.—Specifying additional welding information.

Multiple-Weld Symbols

When you are fabricating a metal part, there are times when more than one type of weld is needed on the same joint; for example, a joint may require both a bevel groove weld and a fillet weld. Two methods of illustrating these weld symbols are shown in figure 3-54. Note that in each welding symbol, the bevel groove weld is to be completed first, followed by the fillet weld.

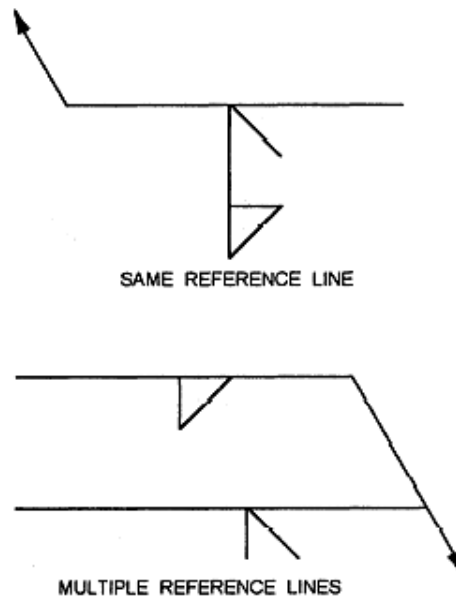

Figure 3-54.—Representing multiple welds.

Applying a Welding Symbol

Figure 3-55 shows an example of how a welding symbol may appear on a drawing. This figure shows a steel pipe column that is to be welded to a baseplate. The symbol tells the welder that the pipe is to be beveled at a 30-degree angle followed by a bevel groove weld all around the joint. This is followed by a 1/2-inch fillet weld that is also welded all around the joint. Finally, finish the fillet weld by grinding it to a flush contour. As the field weld symbol indicates, all welds are to be accomplished in the field.

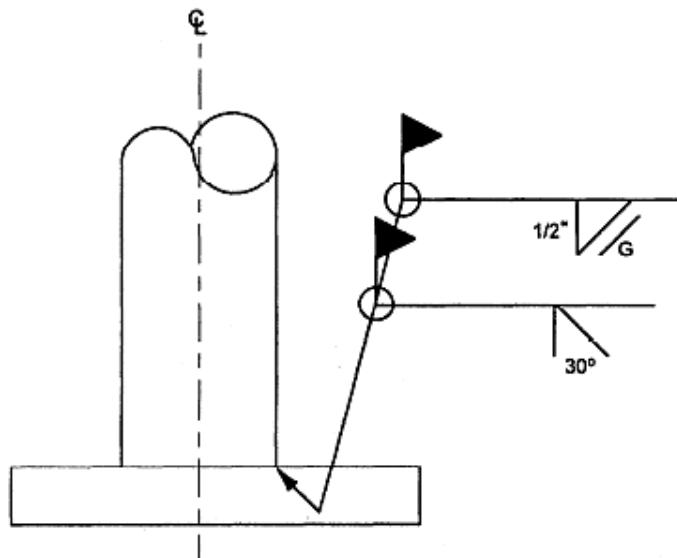

Figure 3-55.—Example of welding symbol in use.

Safety

Mishaps frequently occur in welding operations. In many instances, they result in serious injury to the welder or other personnel working in the immediate area. In most cases, mishaps occur because of carelessness, lack of knowledge, and the misuse of available equipment. Precautions that apply to specific welding equipment are pointed out in the chapters that cover that equipment. In this section we are particularly interested in such topics as protective clothing, eye protection devices, and practices applicable to the personal safety of the operator and personnel working nearby.

Proper eye protection is of the utmost importance. This covers the welding operator and the other personnel, such as helpers, chippers, or inspectors, who are in the vicinity of the welding and cutting operations. Eye protection is necessary because of the hazards posed by stray flashes, reflected glare, flying sparks, and globules of molten metal. Devices used for eye protection include helmets and goggles.

NOTE

In addition to providing eye protection, helmets also provide a shield against flying metal and ultraviolet rays for the entire face and neck.

Figure 3-56 shows several types of eye protection devices in common use.

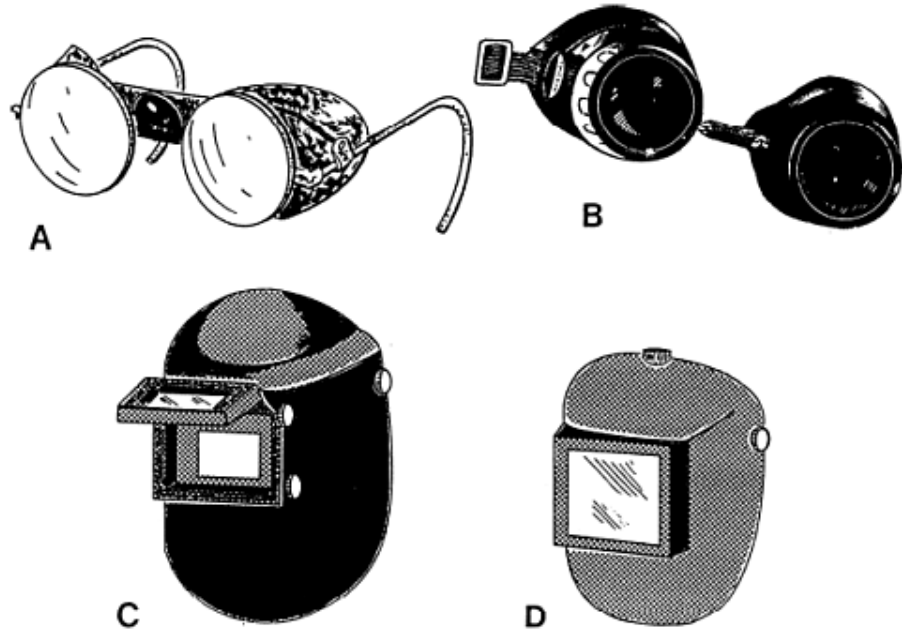

Figure 3-56.—Eye protection devices.

Flash goggles (view A) are worn under the welder's helmet and by persons working around the area where welding operations are taking place. This spectacle type of goggles has side shields and may have either an adjustable or nonadjustable nose bridge.

Eyecup or cover type of goggles (view B) are for use in fuel-gas welding or cutting operations. They are contoured to fit the configuration of the face. These goggles must be fitted with a shade of filter lens that is suitable for the type of work being done.

NOTE

The eyecup or cover type of goggles are NOT to be used as a substitute for an arc-welding helmet.

For electric arc-welding and arc-cutting operations, a helmet having a suitable filter lens is necessary. The helmet shown in view C has an opening, called a window, for a flip-up filter lens 2 inches by 4 1/4 inches in size. The helmet shown in view D has a 4 1/2-inch by 5 1/4-inch window. The larger window affords the welder a wider view and is especially useful when the welder is working in a confined place where head and body movement is restricted. When welding in locations where other welders are working, the welder should wear flash goggles beneath his helmet to provide protection from the flashes caused by the other welders' arcs. The flash goggles will also serve as eye protection when chipping the slag from a previous weld deposit.

Helmets and welding goggles used for eye protection are made from a nonflammable insulating material. They are fitted with a removable protective colored filter and a clear cover lens.

NOTE

The purpose of the clear cover lens is to protect the filter lens against pitting caused by sparks and hot metal spatter. The clear lens must be placed on the outside of the filter lens. The clear lens should be replaced when it impairs vision.

Filter lenses are furnished in a variety of shades, which are designated by number. The lower the number, the lighter the shade; the higher the number, the darker the shade. Table 3-1 shows you the recommended filter lens shade for various welding operations. The filter lens shade number selected depends on the type of work and somewhat on the preference of the user. Remember, a filter lens serves two purposes. The first is to diminish the intensity of the visible light to a point where there is no glare and the welding area can be clearly seen. The second is to eliminate the harmful infrared and ultraviolet radiations coming from the arc or flame; consequently, the filter lens shade number you select must not vary more than two shades from the numbers

recommended in table 3-1.

Table 3-1.—Recommended Filter Lenses for Various Welding Operations

Shade No.	Operation
Up to 4	Light electric spot welding or for protection from stray light from nearby welding.
5	Light gas cutting and welding.
6-7	Gas cutting, medium gas welding, and arc welding up to 30 amperes.
8-9	Heavy gas welding and arc welding and cutting, 30-75 amperes.
10-11	Arc welding and cutting, 76-200 amperes.
12	Arc welding and cutting, 201-400 amperes.
13-14	Arc welding and cutting exceeding 400 amperes.

Rule of thumb: When selecting the proper shade of filter lens for electric-arc welding helmets, place the lens in the helmet and look through the lens as if you were welding. Look at an exposed bare light bulb and see if you can distinguish its outline. If you can, then use the next darker shade lens. Repeat the test again. When you no longer see the outline of the bulb, then the lens is of the proper shade. Remember that this test should be performed in the same lighting conditions as the welding operation is to be performed. Welding in a shop may require a shade lighter lens than if the same job were being performed in bright daylight. For field operations, this test may be performed by looking at a bright reflective object.

WARNING

Never look at the welding arc without proper eye protection. Looking at the arc with the naked eye could lead to permanent eye damage. If you receive flash burns, they should be treated by medical personnel.

A variety of special welder's clothing is used to protect parts of the body. The clothing selected varies with the size, location, and nature of the work to be performed. During any welding or cutting operation, you should always wear flameproof gauntlets. (See fig. 3-57.) For gas welding and cutting, five-finger gloves like those shown in view A should be used. For electric-arc welding, use the two-finger gloves (or mitts) shown in view B.



Figure 3-57.—Welding gloves and mitts.

Both types of gloves protect the hands from heat and metal spatter. The two-finger gloves have an advantage over the five-finger gloves in that they reduce the danger of weld spatter and sparks lodging between the fingers. They also reduce finger chafing which sometimes occurs when five-finger gloves are worn for electric-arc welding.

Many light-gas welding and brazing jobs require no special protective clothing other than gloves and goggles. Even here, it is essential that you wear your work clothes properly. Sparks are very likely to lodge in rolled-up sleeves, pockets of clothing, or cuffs of trousers or overalls. Sleeves should be rolled down and the cuffs buttoned. The shirt collar, also, should be fully buttoned. Trousers should not be cuffed on the outside, and pockets not protected by button-down flaps should be eliminated from the front of overalls and aprons. All other clothing must be free of oil and grease. Wear high top-safety shoes; low-cut shoes are a hazard because sparks and molten metal could lodge in them, especially when you are sitting down.

Medium- and heavy-gas welding, all-electric welding, and welding in the vertical or overhead welding position require special flameproof clothing made of leather or other suitable material. This clothing is designed to protect you against radiated heat, splashes of hot metal, or sparks. This clothing consists of aprons, sleeves, combination sleeves and bib, jackets, and overalls. They afford a choice of protection depending upon the specific nature of the particular welding or cutting job. Sleeves provide satisfactory protection for welding operations at floor or bench level.

The cape and sleeves are particularly suited for overhead welding, because it protects the back of the neck, top of the shoulders, and the upper part of the back and chest. Use of the bib, in combination with the cape and sleeves, gives added protection to the chest and abdomen. The jacket should be worn when there is a need for complete all-around protection to the upperpart of the body. This is especially true when several welders are working in close proximity to one another. Aprons and overalls provide protection to the legs and are suited for welding operations on the floor. Figure 3-58 shows some of the protective clothing available to welders.



Figure 3-58.—Welder's protective clothing.

To prevent head burns during overhead welding operations, you should wear leather or flameproof caps under the helmet. Earplugs also should be worn to keep sparks or splatter from entering and burning the ears. Where the welder is exposed to falling or sharp objects, combination welding helmet/hard hats should be used. For very heavy work, fire-resistant leggings or high boots should be worn. Shoes or boots having exposed nailheads or rivets should NOT be worn. Oilskins or plastic clothing must NOT be worn in any welding operation.

NOTE

If leather protective clothing is not available, then woolen clothing is preferable to cotton.

[Return to the Table of Contents](#)

Woolen clothing is not as flammable as cotton and helps protect the operator from the changes in temperature caused by welding. Cotton clothing, if used, should be chemically treated to reduce its flammability.

All Types of WIRE

Wire in All Metals and Coverings Knitted WIRE Tel 013712 38013



David L. Heiserman, Editor

Copyright © SweetHaven Publishing Services
All Rights Reserved

Revised: December 03, 2014