

# Lesson 4

## Gas Cutting

The common methods used in cutting metal are oxygas flame cutting, air carbon-arc cutting, and plasma-arc cutting. The method used depends on the type of metal to be cut and the availability of equipment. As a welder, oxygas or air carbon-arc equipment is the most common type of equipment available for your use.

The oxygas cutting torch has many uses in steelwork. Often, the welder finds the cutting torch an excellent tool for cutting ferrous metals. This versatile tool is used for operations, such as beveling plate, cutting and beveling pipe, piercing holes in steel plate, and cutting wire rope.

When using the oxygas cutting process, you heat a spot on the metal to the kindling or ignition temperature (between 1400°F and 1600°F for steels). The term for this oxygas flame is the preheating flame. Next, you direct a jet of pure oxygen at the heated metal by pressing a lever on the cutting torch. The oxygen causes a chemical reaction known as oxidation to take place rapidly. When oxidation occurs rapidly, it is called combustion or burning. When it occurs slowly, it is known as rusting.

When you use the oxygas torch method to cut metal, the oxidation of the metal is extremely rapid and part of the metal actually burns. The heat, liberated by the burning of the iron or steel, melts the iron oxide formed by the chemical reaction and accelerates the preheating of the object you are cutting. The molten material runs off as slag, exposing more iron or steel to the oxygen jet.

In oxygas cutting, only that portion of the metal that is in the direct path of the oxygen jet is oxidized. The narrow slit, formed in the metal as the cutting progresses, is called the kerf. Most of the material removed from the kerf is in the form of oxides (products of the oxidation reaction). The remainder of the material is molten metal that is blown or washed out of the kerf by the force of the oxygen jet.

The walls of the kerf formed by oxygas cutting of ferrous metals should be fairly smooth and parallel to each other. After developing your skills in handling the torch, you can keep the cut within close tolerances; guide the cut along straight, curved, or irregular lines; and cut bevels or other shapes that require holding the torch at an angle. Partial oxidation of the metal is a vital part of the oxygas cutting process. Because of this, metals that do not oxidize readily are not suitable for oxygas cutting. Carbon steels are easily cut by the oxygas process, but special techniques (described later in this chapter) are required for the cutting of many other metals.

### Oxygas Cutting Equipment

An oxygas cutting outfit usually consists of a cylinder of acetylene or MAPP gas, a cylinder of oxygen, two regulators, two lengths of hose with fittings, and a cutting torch with tips (fig. 4-1). An oxygas cutting outfit also is referred to as a cutting rig.

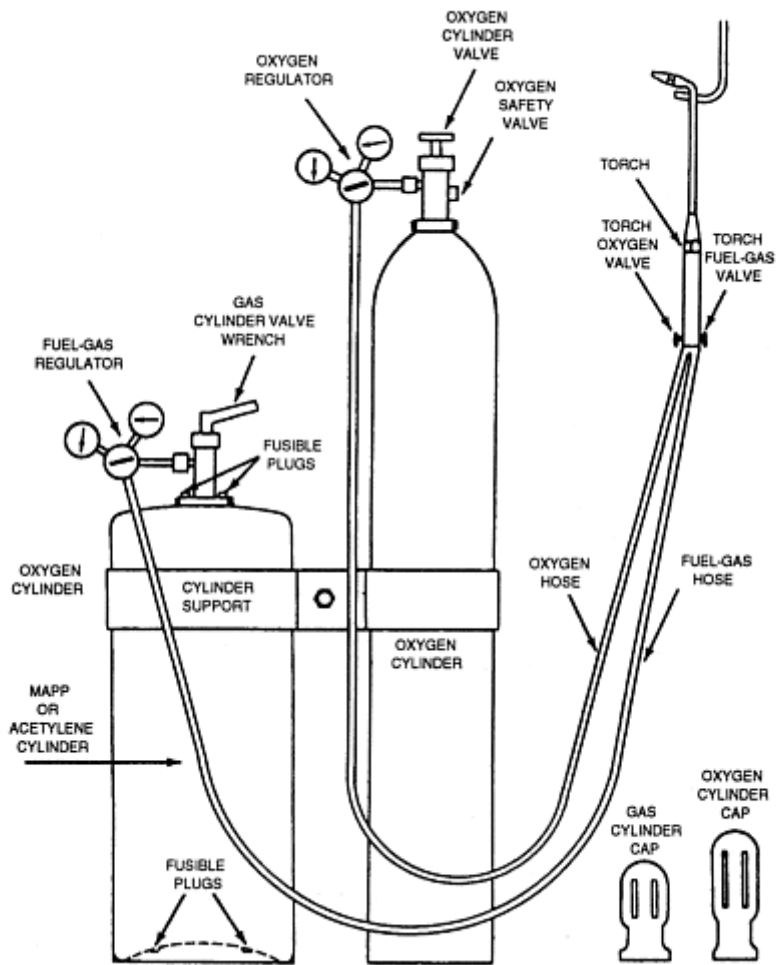


Figure 4-1.—Oxygas cutting outfit.

In addition to the basic equipment mentioned above, numerous types of auxiliary equipment are used in oxygas cutting. An important item is the spark igniter that is used to light the torch (fig. 4-2, view A). Another item you use is an apparatus wrench. It is similar in design to the one shown in figure 4-2, view B. The apparatus wrench is sometimes called a gang wrench because it fits all the connections on the cutting rig. Note that the wrench shown has a raised opening in the handle that serves as an acetylene tank key.

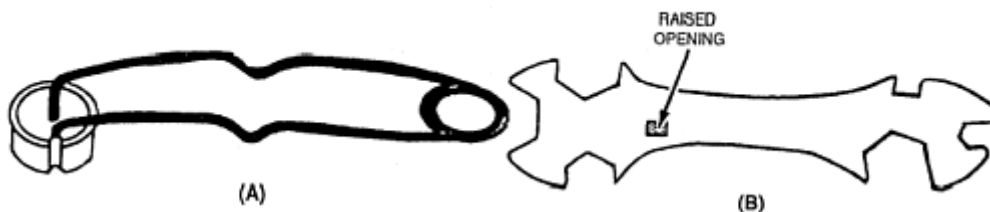


Figure 4-2.—(A) Spark igniter; (B) apparatus wrench.

Other common accessories include tip cleaners, cylinder trucks, clamps, and holding jigs. Personal safety apparel, such as goggles, hand shields, gloves, leather aprons, sleeves, and leggings, are essential and should be worn as required for the job at hand.

Oxygas cutting equipment can be stationary or portable. A portable oxygas outfit, such as the one shown in figure 4-3, is an advantage when it is necessary to move the equipment from one job to another.

To conduct your cutting requirements, you must be able to set up the cutting equipment and make the required adjustments needed to perform the cutting operation. For this reason it is important you understand the purpose and function of the basic pieces of equipment that make up the cutting outfit. But, before discussing the equipment, let's look at the gases most often used in cutting: acetylene, MAPP gas, and oxygen.

## ACETYLENE

Acetylene is a flammable fuel gas composed of carbon and hydrogen having the chemical formula  $C_2H_2$ . When burned with oxygen, acetylene produces a hot flame, having a temperature between  $5700^{\circ}F$  and  $6300^{\circ}F$ . Acetylene is a colourless gas, having a disagree-able odour that is readily detected even when the gas is highly diluted with air. When a portable welding outfit, similar to the one shown in figure 4-3 is used, acetylene is obtained directly from the cylinder. In the case of stationary equipment, similar to the acetylene cylinder bank shown in figure 4-4, the acetylene can be piped to a number of individual cutting stations.

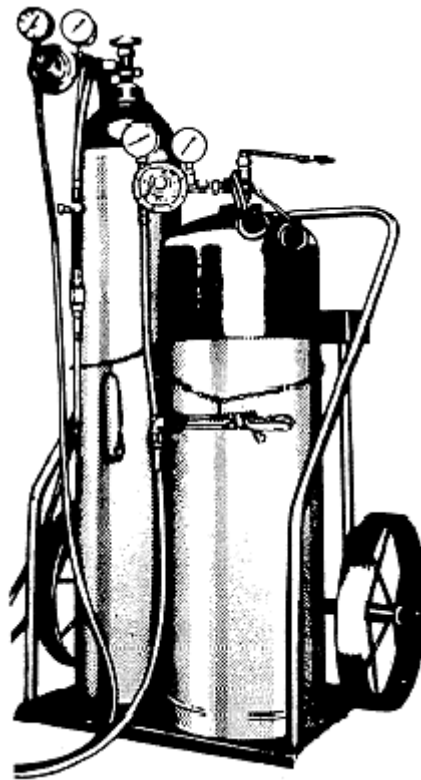


Figure 4-3. - A portable oxygas cutting and welding outfit.

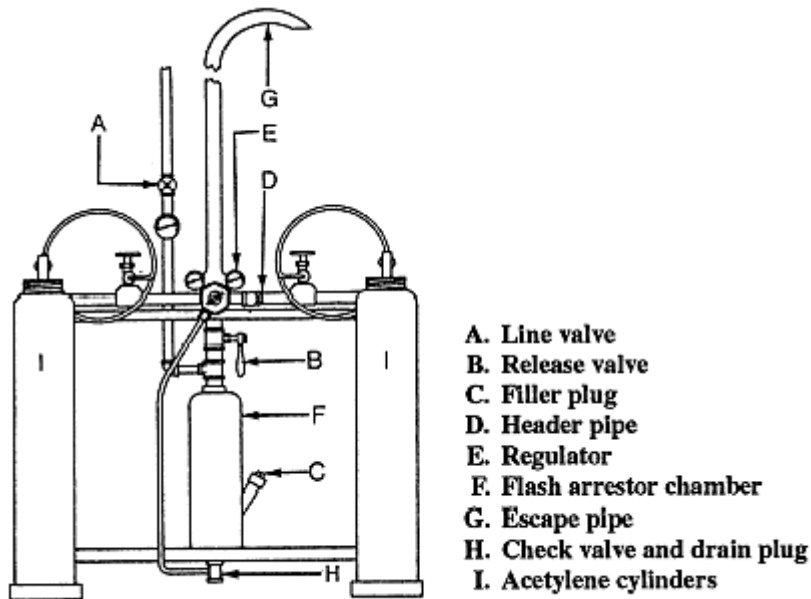


Figure 4-4.—Stationary acetylene cylinder bank.

Hazards Pure acetylene is self-explosive if stored in the free state under a pressure of 29.4 pounds per square inch (psi). A slight shock is likely to cause it to explode.

**WARNING**

Acetylene becomes extremely dangerous if used above 15 pounds pressure

**Cylinder Design**

Acetylene can be safely compressed up to 275 psi when dissolved in acetone and stored in specially designed cylinders filled with porous material, such as balsa wood, charcoal, finely shredded asbestos, corn pith, portland cement, or infusorial earth. These porous filler materials aid in the prevention of high-pressure gas pockets forming in the cylinder.

Acetone is a liquid chemical that dissolves large portions of acetylene under pressure without changing the nature of the gas. Being a liquid, acetone can be drawn from an acetylene cylinder when it is not upright. You should not store acetylene cylinders on their side, but if they are, you must let the cylinder stand upright for a minimum of 2 hours before using. This allows the acetone to settle to the bottom of the cylinder.

**NOTE**

Acetone contaminates the hoses, regulators, torch, and disrupts the flame.

Acetylene is measured in cubic feet. The most common cylinder sizes are 130-, 290-, and 330-cubic-foot capacity. A common standard size cylinder holds

225 cubic feet of acetylene. Just because a cylinder has a 225-cubic-foot capacity does not necessarily mean it has 225 cubic feet of acetylene in it. Because it is dissolved in acetone, you

cannot judge how much acetylene is left in a cylinder by gauge pressure. The pressure of the acetylene cylinder will remain fairly constant until most of the gas is consumed.

An example of an acetylene cylinder is shown in figure 4-5. These cylinders are equipped with fusible plugs that relieve excess pressure if the cylinder is exposed to undue heat. A common standard acetylene cylinder contains 225 cubic feet of acetylene and weighs about 250 pounds. The acetylene cylinder is yellow, and all compressed-gas cylinders are color-coded for identification. More on the colour coding of cylinders is covered later in this lesson.

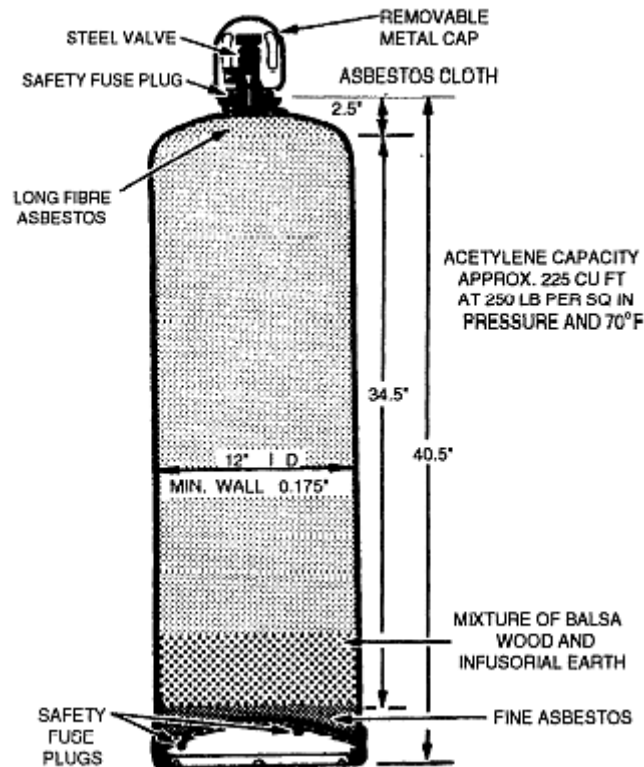


Figure 4-5.—Acetylene cylinder.

## MAPP GAS

MAPP (methylacetylene-propadiene) is an all-purpose industrial fuel having the high-flame temperature of acetylene but has the handling characteristics of propane. Being a liquid, MAPP is sold by the pound, rather than by the cubic foot, as with acetylene. One cylinder containing 70 pounds of MAPP gas can accomplish the work of more than six and one-half 225-cubic-foot acetylene cylinders; therefore, 70 pounds of MAPP gas is equal to 1,500 cubic feet of acetylene.

## Cylinder Design

Total weight for a MAPP cylinder, which has the same physical size as a 225-cubic-foot acetylene cylinder, is 120 pounds (70 pounds which is MAPP gas). MAPP cylinders contain only liquid fuel. There is no cylinder packing or acetone to impair fuel withdrawal; therefore, the entire contents of a MAPP cylinder can be used. For heavy-use situations, a MAPP cylinder delivers more than twice as much gas as an acetylene cylinder for the same time period.

## **MAPP Characteristics**

Because of its superior heat transfer characteristics, MAPP produces a flame temperature of 5300°F when burned with oxygen. MAPP equals, or exceeds, the performance of acetylene for cutting, heating, and brazing.

MAPP is not sensitive to shock and is non-flammable in the absence of oxygen. There is no chance of an explosion if a cylinder is bumped, jarred, or dropped. You can store or transport the cylinders in any position with no danger of forming an explosive gas pocket.

The characteristic odour, while harmless, gives warnings of fuel leaks in the equipment long before a dangerous condition can occur. MAPP gas is not restricted to a maximum working pressure of 15 psig, as is acetylene. In jobs requiring higher pressures and gas flows, MAPP can be used safely at the full-cylinder pressure of 95 psig at 70°F. Because of this, MAPP is an excellent gas for underwater work.

## **Bulk MAPP Gas**

Bulk MAPP gas facilities, similar to liquid oxygen stations, are installed at some activities where large supplies of the gas are used. In bulk installations, MAPP gas is delivered through a piping system directly to the user points. Maximum pressure is controlled centrally for efficiency and economy.

Cylinder-filling facilities are also available from bulk installations that allow users to fill their cylinders on site. Filling a 70-pound MAPP cylinder takes one man about 1 minute and is essentially like pumping water from a large tank to a smaller one.

## **MAPP Gas Safety**

MAPP gas vapour is stable up to 600°F and 1,100 psig when exposed to an 825°F probe. The explosive limits of MAPP gas are 3.4 percent to 10.8 percent in air or 2.5 percent to 80 percent in oxygen. As shown in figure 4-6, you can see these limits are narrow in comparison with that of acetylene.

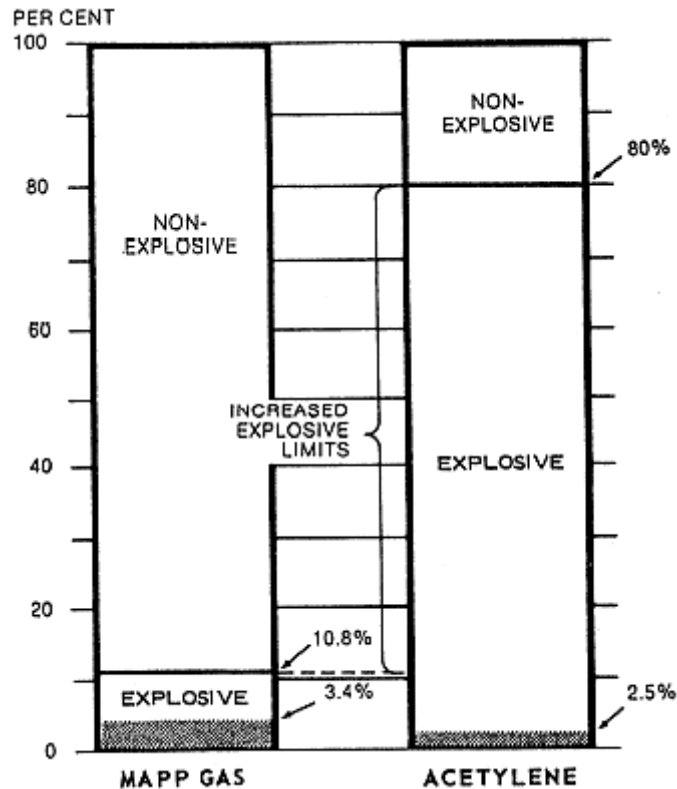


Figure 4-6.—Explosive limits of MAPP and acetylene in air.

MAPP gas has a highly detectable odour. The smell is detectable at 100 ppm, or at a concentration of 1/340th of its lower explosive limit. Small fuel-gas systems may leak 1 or 1 1/2 pounds of fuel or more in an 8-hour shift; bulk systems will leak even more. Fuel-gas leaks are often difficult to find and often go unnoticed; however, a MAPP gas leak is easy to detect and can be repaired before it becomes dangerous.

MAPP toxicity is rated “very slight,” but high concentrations (5,000 ppm) may have an anesthetic effect. Local eye or skin contact with MAPP gas vapor causes no adverse effect; however, the liquid fuel can cause dangerous frostlike burns due to the cooling caused by the rapid evaporation of the liquid.

The identification markings on a MAPP cylinder are a yellow body with band “B” colored orange and the top yellow.

## OXYGEN

Oxygen is a colorless, tasteless, and odorless gas and is slightly heavier than air. It is non-flammable but supports combustion with other elements. In its free state, oxygen is one of the more common elements. The atmosphere is made up of about 21 parts of oxygen and 78 parts of nitrogen, the remainder being rare gases. Rusting of ferrous metals, discoloration of copper, and corrosion of aluminium are all due to the action of atmospheric oxygen. This action is known as oxidation.

Oxygen is obtained commercially either by the liquid-air process or by the electrolytic process. In the liquid-air process, the air is compressed and then cooled to a point where the gases become liquid (approximately  $-375^{\circ}\text{F}$ ). The temperature is then raised to above  $-321^{\circ}\text{F}$ , at which point the nitrogen in the air becomes gas again and is removed. When the temperature of

the remaining liquid is raised to  $-297^{\circ}\text{F}$ , the oxygen forms gas and is drawn off. The oxygen is further purified and compressed into cylinders for use.

The other process by which oxygen is produced—the electrolytic process—consists of running an electrical current through water to which an acid or an alkali has been added. The oxygen collects at the positive terminal and is drawn off through pipes to a container.

Oxygen is supplied for oxyacetylene welding in seamless steel cylinders. A typical oxygen cylinder is shown in figure 4-7. The color of a standard oxygen cylinder used for industrial purposes is solid green. Oxygen cylinders are made in several sizes. The size most often used in welding and cutting is the 244-cubic-foot capacity cylinder. This cylinder is 9 inches in diameter, 51 inches high, and weighs about 145 pounds and is charged to a pressure of 2,200 psi at  $70^{\circ}\text{F}$ .

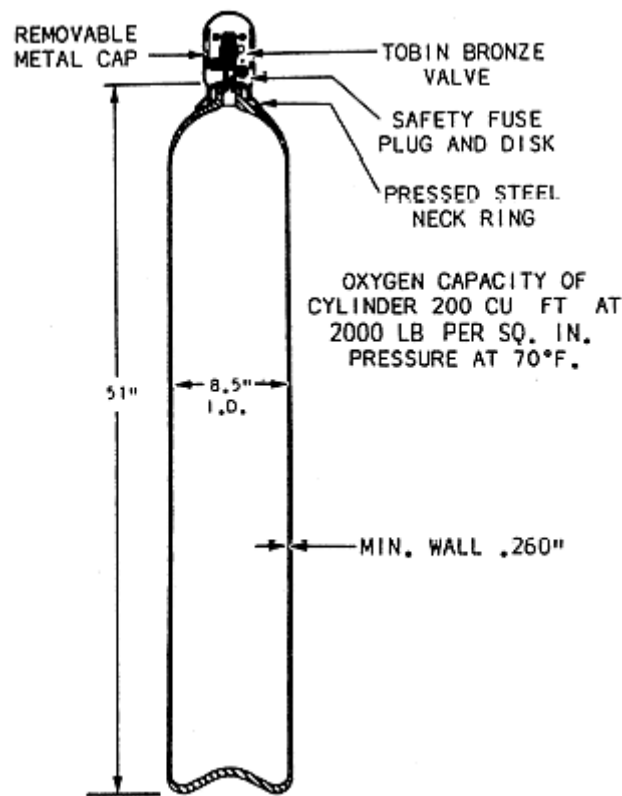


Figure 4-7.—Typical oxygen cylinder.

You can determine the amount of oxygen in a compressed gas cylinder by reading the volume scale on the high-pressure gauge attached to the regulator.

## REGULATORS

You must be able to reduce the high-pressure gas in a cylinder to a working pressure before you can use it. This pressure reduction is done by a regulator or reducing valve. The one basic job of all regulators is to take the high-pressure gas from the cylinder and reduce it to a level that can be safely used. Not only do they control the pressure but they also control the flow (volume of gas per hour).



Regulators come in all sizes and types. Some are designed for high-pressure oxygen cylinders (2,200 psig), while others are designed for low-pressure gases, such as natural gas (5 psig). Some gases like nitrous oxide or carbon dioxide freeze when their pressure is reduced so they require electrically heated regulators.

Most regulators have two gauges: one indicates the cylinder pressure when the valve is opened and the other indicates the pressure of the gas coming out of the regulator. You must open the regulator before you get a reading on the second gauge. This is the delivery pressure of the gas, and you must set the pressure that you need for your particular job.

The pressures that you read on regulator gauges is called gauge pressure. If you are using pounds per square inch, it should be written as psig (this acronym means pounds per square inch gauge). When the gauge on a cylinder reads zero, this does not mean that the cylinder is empty. In actuality, the cylinder is still full of gas, but the pressure is equal to the surrounding atmospheric pressure. Remember: no gas cylinder is empty unless it has been pumped out by a vacuum pump.

There are two types of regulators that control the flow of gas from a cylinder. These are either single-stage or double-stage regulators.

### Single-Stage Regulators

Regulators are used on both high- and low-pressure systems. Figure 4-8 shows two SINGLE-STAGE regulators: one for acetylene and one for oxygen. The regulator mechanism consists of a nozzle through which the gases pass, a valve seat to close off the nozzle, a diaphragm, and balancing springs. These mechanisms are all enclosed in a suitable housing. Fuel-gas regulators and oxygen regulators are basically the same design. The difference being those designed for fuel gases are not made to withstand the high pressures that oxygen regulators are subjected to.

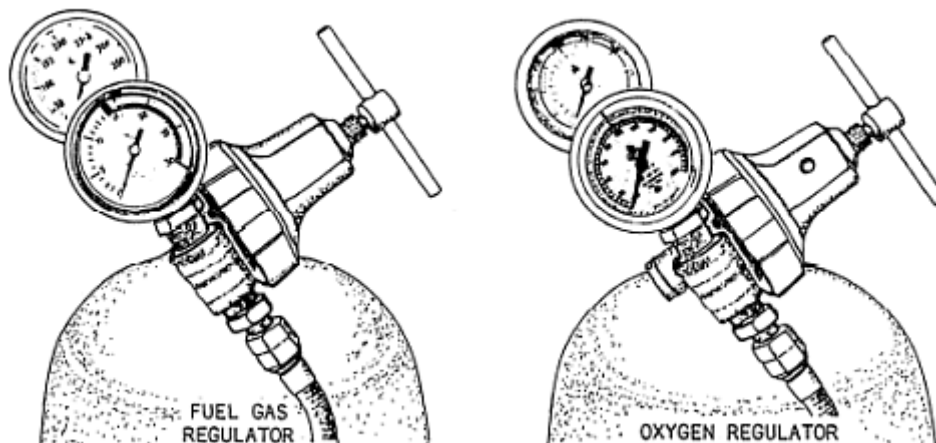


Figure 4-8.—Single-stage regulators.

In the oxygen regulator, the oxygen enters through the high-pressure inlet connection and passes through a glass wool filter that removes dust and dirt. Turning the adjusting screw IN (clockwise) allows the oxygen to pass from the high-pressure chamber to the low-pressure chamber of the regulator, through the regulator outlet, and through the hose to the torch. Turning the adjusting screw further clockwise increases the working pressure; turning it counter clockwise decreases the working pressure.

The high-pressure gauge on an oxygen regulator is graduated from 0 to 3,000 psig and from 0 to 220 in cubic feet. This allows readings of the gauge to determine cylinder pressure and cubic content. Gauges are calibrated to read correctly at 70°F. The working pressure gauge may be graduated in "psig" from 0 to 150, 0 to 200, or from 0 to 400, depending upon the type of regulator used. For example, on regulators designed for heavy cutting, the working pressure gauge is graduated from 0 to 400.

The major disadvantage of single-stage regulators is that the working gas pressure you set will decrease as the cylinder pressure decreases; therefore, you must constantly monitor and reset the regulator if you require a fixed pressure and flow rate. Keeping the gas pressure and flow rate constant is too much to expect from a regulator that has to reduce the pressure of a full cylinder from 2,200 psig to 5 psig. This is where double-stage regulators solve the problem.

## Double-Stage Regulators

The double-stage regulator is similar in principle to the one-stage regulator. The main difference being that the total pressure drop takes place in two stages instead of one. In the high-pressure stage, the cylinder pressure is reduced to an intermediate pressure that was predetermined by the manufacturer. In the low-pressure stage, the pressure is again reduced from the intermediate pressure to the working pressure you have chosen. A typical double-stage regulator is shown in figure 4-9.

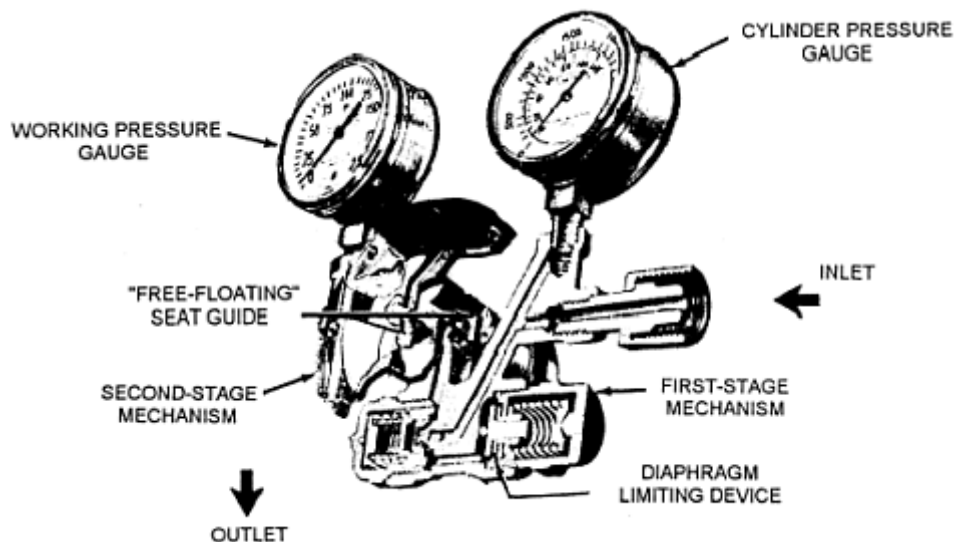


Figure 4-9.—Double-stage regulator.

## Problems and Safety

Regulators are precise and complicated pieces of equipment. Carelessness can do more to ruin a regulator than any other gas-using equipment. One can easily damage a regulator by simply forgetting to wipe clean the cylinder, regulator, or hose connections. When you open a high-pressure cylinder, the gas can rush into the regulator at the speed of sound. If there is any dirt present in the connections, it will be blasted into the precision-fitted valve seats, causing them to leak. This results in a condition that is known as creep. Creep occurs when you shut off the regulator but not the cylinder and gas pressure is still being delivered to the low-pressure side.

Regulators are built with a minimum of two relief devices that protect you and the equipment in the case of regulator creep or high-pressure gas being released into the regulator all at once. All regulator gauges have blowout backs that release the pressure from the back of the gauge before the gauge glass explodes. Nowadays, most manufacturers use shatterproof plastic instead of glass.

The regulator body is also protected by safety devices. Blowout disks or spring-loaded relief valves are the two most common types of devices used. When a blowout disk ruptures, it sounds like a cannon. Spring-loaded relief valves usually make howling or shrieking like noises. In either case, your first action, after you recover from your initial fright, should be to turn off the cylinder valve. Remove the regulator and tag it for repair or disposal.

When opening a gas cylinder, you should just “crack” the valve a little. This should be done before attaching the regulator and every time thereafter. By opening the cylinder before connecting the regulator, you blow out any dirt or other foreign material that might be in the cylinder nozzle. Also, there is the possibility of a regulator exploding if the cylinder valve is opened rapidly.

### WARNING

Oil or other petroleum products must never be used around oxygen regulators because these products will either cause a regulator explosion or fire

## HOSES

The hoses used to make the connections between the torch and the regulators must be strong, nonporous, light, and flexible enough to make torch movements easy. They must be made to withstand internal pressures that can reach as high as 100 psig. The rubber used in hose manufacture is specially treated to remove the sulphur that could cause spontaneous combustion.

Welding hose is available in single- and double-hose lengths. Size is determined by the inside diameter, and the proper size to use depends on the type of work for which it is intended. Hose used for light work has a 3/16 or 1/4 inch inside diameter and one or two plies of fabric. For heavy-duty welding and cutting operations, use a hose with an inside diameter of 5/16 inch and three to five plies of fabric. Single hose is available in the standard sizes as well as 1/2-, 3/4-, and 1-inch sizes. These larger sizes are for heavy-duty heating and for use on large cutting machines.

The most common type of cutting and welding hose is the twin or double hose that consists of the fuel hose and the oxygen hose joined together side by side. They are joined together by either a special rib (fig. 4-10, view A) or by clamps (fig. 4-10, view B). Because they are joined together, the hoses are less likely to become tangled and are easier to move from place.

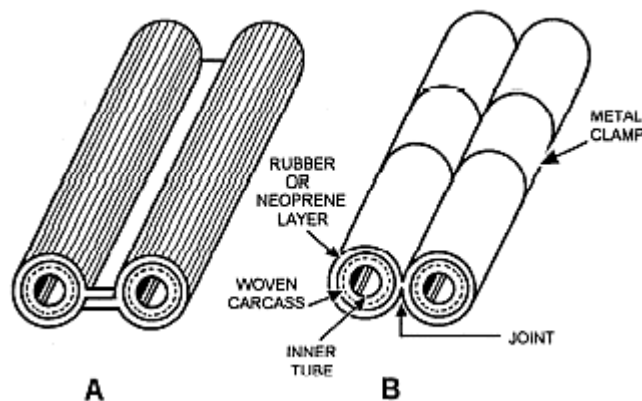


Figure 4-10.—Types of twin welding hose.

The length of hose you use is important. The delivery pressure at the torch varies with the length of the hose. A 20-foot, 3/16-inch hose maybe adequate for a job, but if the same hose was 50 feet long, the pressure drop would result in insufficient gas flow to the torch. Longer hoses require larger inside diameters to ensure the correct flow of gas to the torch. When you are having problems welding or cutting, this is one area to check. The hoses used for fuel gas and oxygen are identical in construction, but they differ in colour. The oxygen hose cover is GREEN, and the fuel-gas hose cover is RED. This colour coding aids in the prevention of mishaps that could lead to dangerous accidents.

All connections for welding and cutting hoses have been standardized by the Compressed Gas Association. Letter grades A, B, C, D, and E plus the type of gas used correspond directly with the connections on the regulators. A, B, and C are the most common size connections. A-size is for low-flow rates; B-size for medium-flow rates; and C-size is for heavy-flow rates. D and E sizes are for large cutting and heating torches.

When ordering connections, you must specify the type of gas the hose will be carrying. This is because the connections will be threaded differently for different types of gas. Fuel gases use left-hand threads, while oxygen uses right-hand threads. The reason for this is to prevent the accidental hook-up of a fuel gas to a life-support oxygen system or vice versa. The basic hose connection consists of a nut and gland. The nut has threads on the inside that match up with the male inlet and outlet on the torch and regulator. The gland slides inside the hose and is held in place by a ferrule that has been crimped. The nut is loose and can be turned by hand or a wrench to tighten the threaded nut onto the equipment.

Another important item that is often overlooked are check valves. These inexpensive valves prevent personal injuries and save valuable equipment from flashbacks. When ordering, make sure you specify the type of gas, connection size, and thread design. The check valves should be installed between the torch connection and the hose.

## CUTTING TORCHES

The equipment and accessories for oxygas cutting are the same as for oxygas welding except that you use a cutting torch or a cutting attachment instead of a welding torch. The main difference between the cutting torch and the welding torch is that the cutting torch has an additional tube for high-pressure cutting oxygen. The flow of high-pressure oxygen is controlled from a valve on the handle of the cutting torch. In the standard cutting torch, the valve may be in the form of a trigger assembly like the one in figure 4-11. On most torches, the cutting oxygen mechanism is designed so the cutting oxygen can be turned on gradually. The gradual opening of the cutting oxygen valve is particularly helpful in operations, such as hole piercing and rivet cutting.

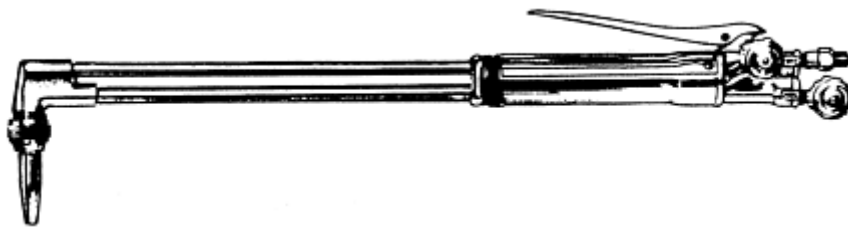


Figure 4-11.—One piece oxygas cutting torch.

### Torch Body

Most welding torches are designed so the body of the torch can accept either welding tips or a cutting attachment. This type of torch is called a combination torch. The advantage of this type

of torch is the ease in changing from the welding mode to the cutting mode. There is no need to disconnect the hoses; you just unscrew the welding tip and then screw on the cutting attachment. The high-pressure cutting oxygen is controlled by a lever on the torch handle, as shown in figure 4-12.

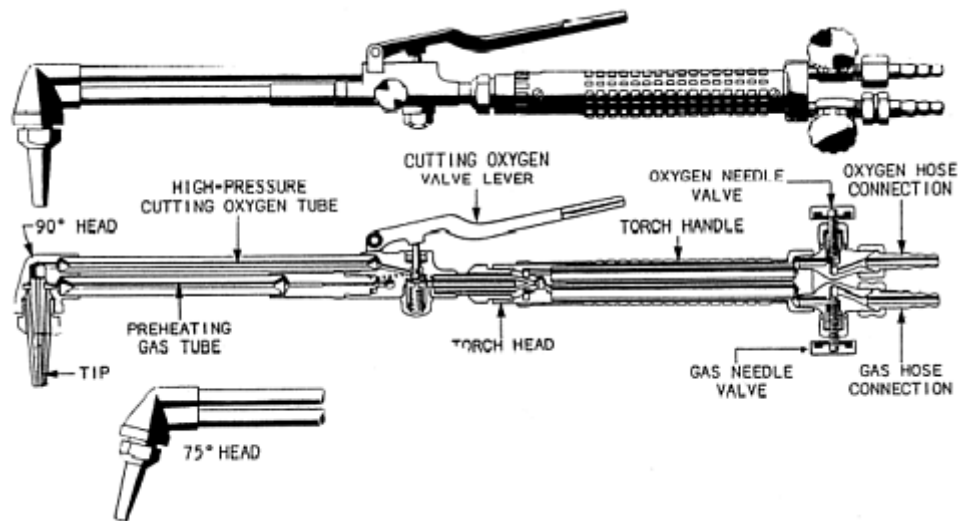


Figure 4-12.—Cutting attachment for combination torch.

## Cutting Torch Tips

As in welding, you must use the proper size cutting tip if quality work is to be done. The preheat flames must furnish just the right amount of heat, and the oxygen jet orifice must deliver the correct amount of oxygen at just the right pressure and velocity to produce a clean cut. All of this must be done with a minimum consumption of oxygen and fuel gases. Careless workers and workers not acquainted with the correct procedures waste both oxygen and fuel gas.

Each manufacturer makes many different types of cutting tips. Although the orifice arrangements and the tips are much the same among the manufacturers, the part of the tip that fits into the torch head often differs in design.

Because of these differences, there is the possibility of having two or three different types of cutting torches in your kits. Make sure that the cutting tips match the cutting attachment and ensure that the cutting attachment matches the torch body. Figure 4-13 shows the different styles of tips, their orifice arrangements and their uses. The tips and sears are designed to produce an even flow of gas and to keep themselves as cool as possible. The seats must produce leakproof joints. If the joints leak, the preheat gases could mix with the cutting oxygen or escape to the atmosphere, resulting in poor cuts or the possibility of flashbacks.

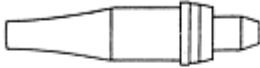



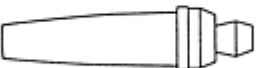

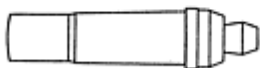







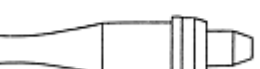

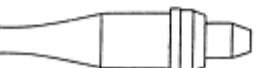

STYLE	PREHEAT	DESCRIPTION	SIZE	TYPE
	 Medium	<b>MAPP* GAS — One-Piece</b> Preheat: Medium. Typical use: Hand and machine cutting.	00-6	1-303M
	 Medium	<b>MAPP* GAS — One-Piece</b> Preheat: Medium. Typical use: Cutting close to bulkheads, hand cutting of rivet heads, machine cutting 35° with torch perpendicular.	1, 2, 3	1-312M
	 Medium	<b>MAPP* GAS — Two-Piece</b> Preheat: Medium. Typical use: General-purpose cutting hand and machine thru 4".	000-4	2-210M
	 Heavy	<b>MAPP* GAS — Two-Piece</b> Preheat: Heavy. Typical use: General-purpose cutting hand and machine 4" and over.	5-8, 10	2-210M
	 Light	<b>ACETYLENE</b> Preheat: Very light. Typical use: Clean metal, Plate cutting and trimming.	00-2	1-110
	 Medium	<b>ACETYLENE</b> Preheat: Medium. Typical use: Clean plate, straight line or circle machine cutting and trimming. Special lengths available on request.	00-4	1-111
	 Medium	<b>ACETYLENE</b> Preheat: Medium. Typical use: Cutting close to bulkheads, hand cutting of rivet heads. Machine cutting 45° with torch perpendicular.	00-4	1-112
	 Light	<b>ACETYLENE</b> Preheat: Light. Typical use: Hand & machine cutting. Clean plate.	0, 1, 2	1-100
	 Medium	<b>ACETYLENE</b> Preheat: Medium. Typical use: General hand & machine cutting.	000-8	1-101

Figure 4-13.—Common cutting torch tips and their uses.

To make clean and economical cuts, you must keep the tip orifices and passages clean and free of burrs and slag. If the tips become dirty or misshapen, they should be put aside for restoration. Figure 4-14 shows four tips: one that is repairable, two that need replacing, and one in good condition. Since it is extremely important that the sealing surfaces be clean and free of scratches or burrs, store the tips in a container that cannot scratch the seats. Aluminium racks, plastic racks, and wood racks or boxes make ideal storage containers.

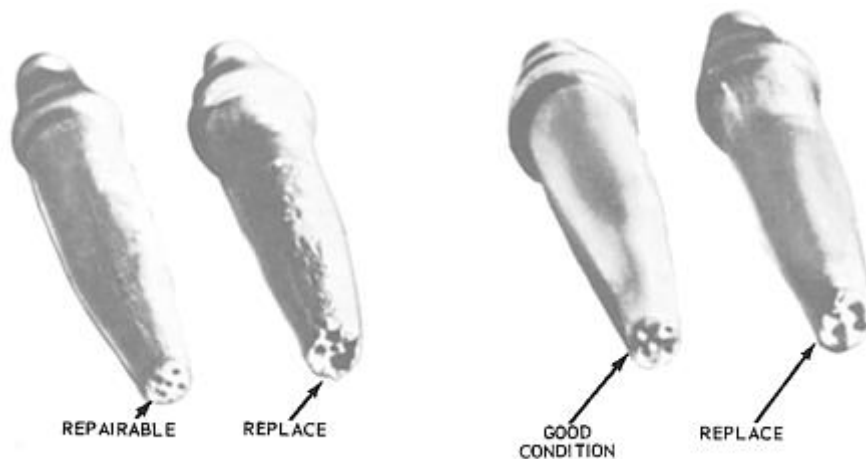


Figure 4-14.—Four cutting-tip conditions.

**TIP MAINTENANCE.** - In cutting operations, the stream of cutting oxygen sometimes blows slag and molten metal into the tip orifices which partially clogs them. When this happens, you should clean the orifices thoroughly before you use the tip again. A small amount of slag or metal in an orifice will seriously interfere with the cutting operation. You should follow the recommendations of the torch manufacturer as to the size of drill or tip cleaner to use for cleaning the orifices. If you do not have a tip cleaner or drill, you may use a piece of soft copper wire. Do not use twist drills, nails, or welding rods for cleaning tips because these items are likely to enlarge and distort the orifices.

Clean the orifices of the cutting torch tip in the same manner as the single orifice of the welding torch tip. Remember: the proper technique for cleaning the tips is to push the cleaner straight in and out of the orifice. Be careful not to turn or twist the cleaning wire. Figure 4-15 shows a typical set of tip cleaners.

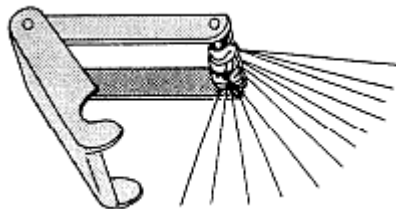


Figure 4-15.—Tip cleaners.

Occasionally the cleaning of the tips causes enlargement and distortion of the orifices, even when using the proper tip cleaners. If the orifices become enlarged, you will get shorter and thicker preheating flames; in addition, the jet of cutting oxygen will spread, rather than leave the torch, in the form of a long, thin stream. If the orifices become belled for a short distance at the end, you can sometimes correct this by rubbing the tip back and forth against emery cloth placed on a flat surface. This action wears down the end of the tip where the orifices have been belled, thus bringing the orifices back to their original size.

Obviously, this procedure will not work if the damage is great or if the bellings extends more than a slight distance into the orifice. After reconditioning a tip, you may test it by lighting the torch and observing the preheating flames. If the flames are too short, the orifices are still partially blocked. If the flames snap out when you close the valves, the orifices are still distorted.

If the tip seat is dirty or scaled and does not properly fit into the torch head, heat the tip to a dull red and quench it in water. This will loosen the scale and dirt enough so you can rub it off with a soft cloth.

**MAPP GAS CUTTING TIPS.** - Four basic types of MAPP gas cutting tips are used: two are for use with standard pressures and normal cutting speeds, and two are for use with high pressures and high cutting speeds. Only the standard pressure tips, types SP and FS, will be covered here since they are the ones that Steelworkers will most likely use. SP stands for standard pressure and FS for fine standard.

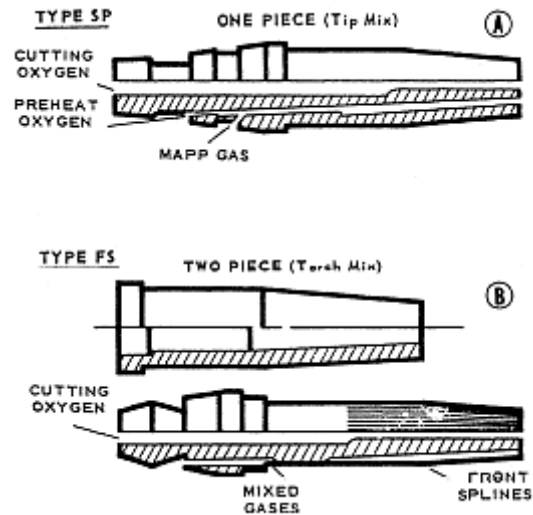


Figure 4-16.—MAPP gas cutting tips.

The SP tip (fig. 4-16, view A) is a one-piece standard pressure tip. It is used for cutting by hand, especially by welders who are accustomed to one-piece tips. SP tips are more likely to be used in situations where MAPP gas is replacing acetylene as the fuel gas.

The FS tip (fig. 4-16, view B) is a two-piece, fine spline, standard pressure tip. It is used for cutting by hand as well as by machine. Welders accustomed to two-piece cutting tips will use them in hand cutting, especially when MAPP gas is replacing natural gas or propane as the fuel gas. The FS tips will produce heavier preheating flames and faster starts than the SP tips; however, two-piece tips will not take as much thermal or physical abuse as one-piece tips. But in the hands of skilled welders, they should last as long as one-piece tips.

Recommended tip sizes and gas pressures for use in cutting different thicknesses of steel using MAPP gas as a fuel are given in table 4-1.



Table 4-1.—Recommended MAPP Gas Tip Sizes and Oxyfuel Pressures

Material Thickness inches (millimeters)	Cutting Tip Number	Oxygen Cutting Pressure (psig)	MAPP Gas Pressure (psig)
1/8 (3)	75	40-50	2-10
3/16 (4.8)	72		
1/4 (6.4)	68		
1/2 (12.7)	61		
3/4 (19)	56		
1 (25.4)	54	50-60	6-10
1 1/4 (31.8)			
1 1/2 (38)			
2 (50.8)			
2 1/2 (63.5)			
3 (76)	48	60-70	
4 (101)			

## Oxygen Cutting Operations

Before you begin a cutting operation with an oxygas cutting torch, make a thorough inspection of the area. Ensure that there are no combustible materials in the area that could be ignited by the sparks or slag produced by the cutting operation. If you are burning into a wall, inspect the opposite side of the wall, and post a fire watch as required.

## EQUIPMENT SETUP

Setting up the oxygas equipment and preparing for cutting must be done carefully and systematically to avoid costly mistakes. To ensure your own safety, as well as the safety of your coworkers and equipment, make sure the following steps are taken before any attempt is made to light the torch:

- Secure the cylinders so they cannot be accidentally knocked over. A good way to do this is to either put them in a corner or next to a vertical column and then secure them with a piece of line. After securing the cylinders, remove the protective caps. Cylinders should never be secured to a structural member of a building that is a current conductor.
- Standing to one side, crack each cylinder valve slightly and then immediately close the valve again. This blows any dirt or other foreign matter out of the cylinder valve nozzle. Do not bleed fuel gas into a confined area because it may ignite. Ensure the valves are closed and wipe the connections with a clean cloth.
- Connect the fuel-gas regulator to the fuel-gas cylinder and the oxygen regulator to the oxygen cylinder. Using a gang wrench, snug the connection nuts sufficiently to avoid leaks.
- Back off the regulator screws to prevent damage to the regulators and gauges and open the cylinder valves slowly. Open the fuel-gas valve only one-half turn and the oxygen valve all the way. Some fuel-gas cylinders have a hand wheel for opening the fuel-gas valve while others require the use of a gang wrench or T-handle wrench. Leave the wrench in place while the cylinder is in use so the fuel-gas bottle can be turned off quickly in an emergency. Read the high-pressure gauge to check the contents in each cylinder.
- Connect the RED hose to the fuel-gas regulator and the GREEN hose to the oxygen regulator. Notice the left-hand threads on the fuel-gas connection.
- To blow out the oxygen hose, turn the regulator screw in (clockwise) and adjust the pressure between 2 and 5 psig. After the hose has been purged, turn the screw back out again (counter clockwise) to shutoff the oxygen. Do the same for the fuel-gas hose,

but do it ONLY in a well-ventilated place that is free from sparks, flames, or other possible sources of ignition.

- Connect the hoses to the torch. The RED (fuel-gas) hose is connected to the connection gland with the needle valve marked "FUEL." The GREEN (oxygen) hose is connected to the connection gland with the needle valve marked "OXY." With the torch valves closed, turn both regulator screws clockwise to test the hose connections for leaks. If none are found, turn the regulator screws counter clockwise and drain the hose by opening the torch valves.
- Select the correct cutting tip and install it in the cutting torch head. Tighten the assembly by hand, and then tighten with your gang wrench.
- Adjust the working pressures. The fuel-gas pressure is adjusted by opening the torch needle valve and turning the fuel-gas regulator screw clockwise.
- Adjust the regulator to the working pressure needed for the particular tip size, and then close the torch needle valve. To adjust MAPP gas, you should set the gauge pressure with the torch valves closed. To adjust the oxygen working pressure, you should open the oxygen torch needle valve and proceed in the same manner as in adjusting the fuel-gas pressure.

In lighting the torch and adjusting the flame, always follow the manufacturer's directions for the particular model of torch being used. This is necessary because the procedure varies somewhat with different types of torches and, in some cases, even with different models made by the same manufacturer.

In general, the procedure used for lighting a torch is to first open the torch oxygen needle valve a small amount and the torch fuel-gas needle valve slightly more, depending upon the type of torch. The mixture of oxygen and fuel gas coming from the torch tip is then lighted by means of a spark igniter or stationary pilot flame.

**CAUTION**

NEVER use matches to light the torch; their length requires bringing the hand too close to the tip. Accumulated gas may envelop the hand and, upon igniting, result in a severe burn. Also, never light the torch from hot metal.

After checking the fuel-gas adjustment, you can adjust the oxygen flame to obtain the desired characteristics for the work at hand, by further manipulating the oxygen and fuel-gas needle valves according to the torch manufacturer's direction.

There are three types of gas flames commonly used for all oxygen processes. They are carburizing, neutral, and oxidizing. To ensure proper flame adjustment, you should know the characteristics of each of these three types of flame. Figure 4-17 shows how the three different flames look when using MAPP gas as the fuel.

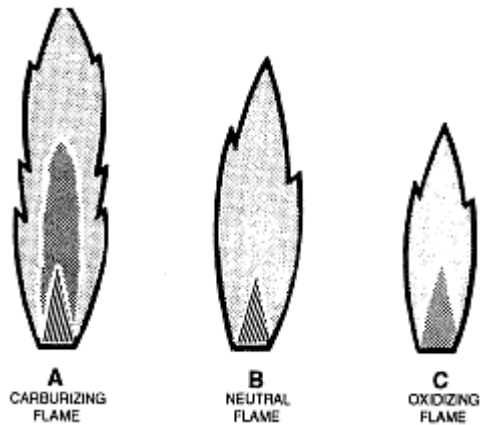


Figure 4-17.—MAPP-gas flames.

A pure fuel-gas flame is long and bushy and has a yellowish colour. It takes the oxygen it needs for combustion from the surrounding air. The oxygen available is not sufficient enough to burn the fuel gas completely; therefore, the flame is smoky and consists of soot. This flame is not suitable for use. You need to increase the amount of oxygen by opening the oxygen needle valve until the flame takes on a bluish white colour, with a bright inner cone surrounded by a flame envelope of a darker hue. It is the inner cone that develops the required operating temperature.

**CARBURIZING FLAME.**- The carburizing flame always shows distinct colours; the inner cone is bluish white, the intermediate cone is white, the outer envelope flame is light blue, and the feather at the tip of the inner cone is greenish. The length of the feather can be used as a basis for judging the degree of carburization. The highly carburizing flame is longer with yellow or white feathers on the inner cone, while the slightly carburizing flame has a shorter feather on the inner cone and becomes whiter. The temperature of carburizing flames is about 5400°F.

Strongly carburizing flames are not used in cutting low-carbon steels because the additional carbon they add causes embrittlement and hardness. These flames are ideal for cutting cast iron because the additional carbon poses no problems and the flame adds more heat to the metal because of its size.

Slightly carburizing flames are ideal for cutting steels and other ferrous metals that produce a large amount of slag. Although a neutral flame is best for most cutting, a slightly carburizing flame is ideal for producing a lot of heat down inside the kerf. It makes fairly smooth cuts and reduces the amount of slag clinging to the bottom of the cut.

**NEUTRAL FLAME.** - The most common preheat flame for oxygas cutting is the neutral flame. When you increase the oxygen, the carburizing flame becomes neutral. The feather will disappear from the inner flame cone and all that will be left is the dark blue inner flame and the lighter blue outer cone. The temperature is about 5600°F.

The neutral flame will not oxidize or add carbon to the metal you are cutting. In actuality, a neutral flame acts like the inert gases that are used in TIG and MIG welding to protect the weld from the atmosphere. When you hold a neutral preheat flame on one spot on the metal until it melts, the molten puddle that forms looks clear and lies very quietly under the flame.

**OXIDIZING FLAME.** - When you add a little more oxygen to the preheat flame, it will quickly be-come shorter. The flame will start to neck down at the base, next to the flame ports. The inner flame cone changes from dark blue to light blue. Oxidizing flames are much easier to look at because they are less radiant than neutral flames. The temperature is about 6000°F.

The oxidizing flame is rarely used for conventional cutting because it produces excessive slag and does not leave square-cut edges. Oxidizing flames are used in conjunction with cutting machines that have a high-low oxygen valve. The machine starts the cut with a oxidizing flame then automatically reverts to a neutral flame. The oxidizing flame gives you fast starts when using high-speed cutting machines and is ideal for piercing holes in plate. Highly oxidizing flames are only used in cutting metal underwater where the only source of oxygen for the torch is supplied from the surface.

## CUTTING MILD-CARBON STEEL

To cut mild-carbon steel with the oxygen cutting torch, you should adjust the preheating flames to neutral. Hold the torch perpendicular to the work, with the inner cones of the preheating flames about 1/16 inch above the end of the line to be cut (fig. 4-18). Hold the torch in this position until the spot you are heating is a bright red. Open the cutting oxygen valve slowly but steadily by pressing down on the cutting valve lever.

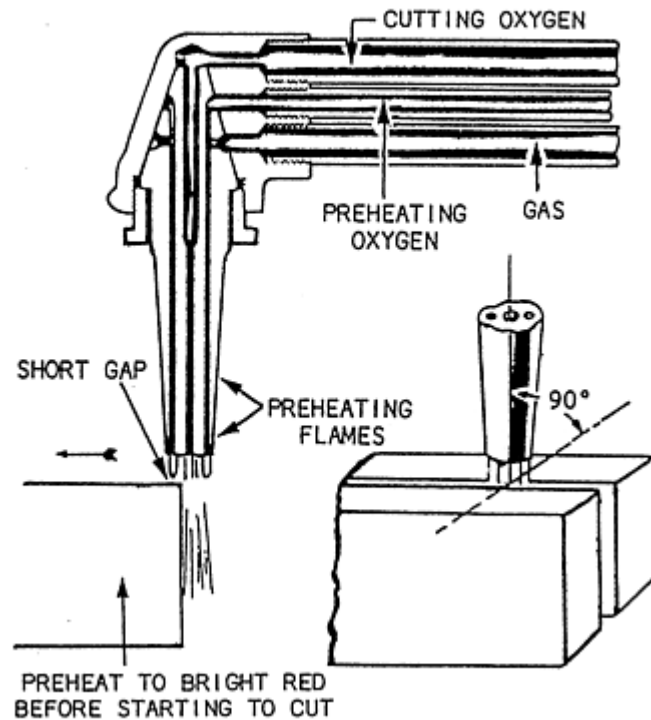


Figure 4-18.—Position of torch tip for starting a cut.

When the cut is started correctly, a shower of sparks will fall from the opposite side of the work, indicating that the flame has pierced the metal. Move the cutting torch forward along the line just fast enough for the flame to continue to penetrate the work completely. If you have made the cut properly, you will get a clean, narrow cut that looks almost like it was made by a saw. When cutting round bars or heavy sections, you can save preheating time by raising a small burr with a chisel where the cut is to begin. This small raised portion will heat quickly, allowing you to start cutting immediately.

Once you start the cut, you should move the torch. Slowly along the cutting mark or guide. As you move the torch along, watch the cut so you can tell how it is progressing. Adjust the torch

as necessary. You must move the torch at the correct speed, not too fast and not too slow. If you go too slowly, the preheating flame melts the top edges along the cut and could weld them back together again. If you go too rapidly, the flame will not penetrate completely, as shown in figure 4-19. When this happens, sparks and slag will blow back towards you. If you have to restart the cut, make sure there is no slag on the opposite side.

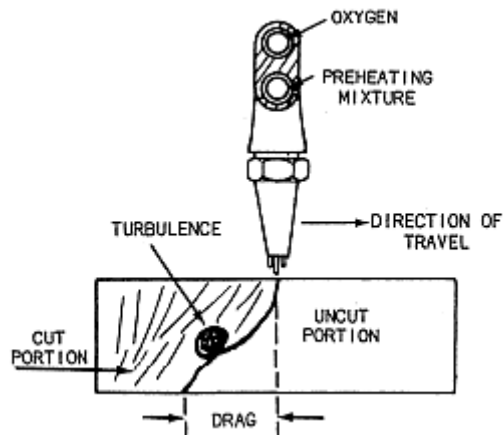


Figure 4-19.—The effect of moving a cutting torch too rapidly across the work.

### Cutting Thin Steel

When cutting steel 1/8 inch or less in thickness, use the smallest cutting tip available. In addition, point the tip in the direction the torch is traveling. By tilting the tip, you give the preheating flames a chance to heat the metal ahead of the oxygen jet, as shown in figure 4-20.

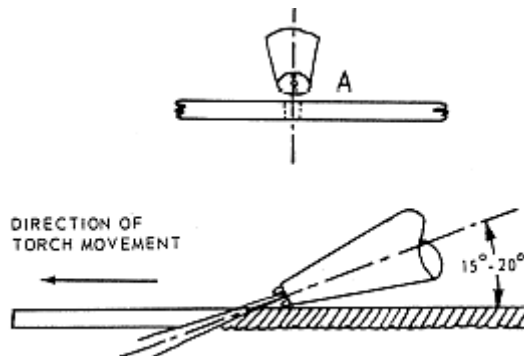


Figure 4-20.—Recommended procedure for cutting thin steel.

If you hold the tip perpendicular to the surface, you decrease the amount of preheated metal and the adjacent metal could cool the cut enough to prevent smooth cutting action. Many welders actually rest the edge of the tip on the metal during this process. If you use this method, be careful to keep the end of the preheating flame inner cone just above the metal.

### Cutting Thick Steel

Steel, that is greater than 1/8 inch thick, can be cut by holding the torch so the tip is almost vertical to the surface of the metal. If you are right-handed, one method to cut steel is to start at the edge of the plate and move from right to left. Left-handed people tend to cut left to right. Either direction is correct and you may cut in the direction that is most comfortable for you. Figure 4-21 shows the progress of a cut in thick steel.

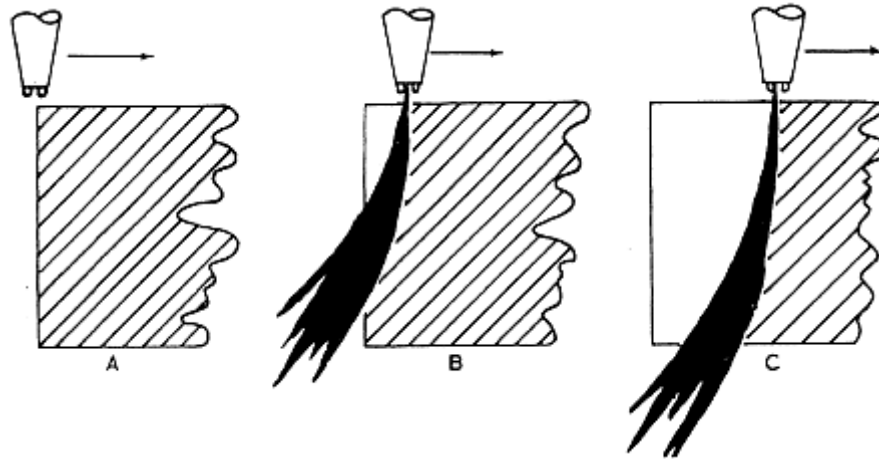


Figure 4-21.—Progress of a cut in thick steel. A. Preheat flames are 1/16 to 1/8 inch from the metal surface. Hold the torch in this spot until the metal becomes cherry red. B. Move the torch slowly to maintain the rapid oxidation, even though the cut is only partially through the metal. C. The cut is made through the entire thickness; the bottom of the kerf lags behind the top edge slightly.

After heating the edge of the steel to a dull cherry red, open the oxygen jet all the way by pressing on the cutting lever. As soon as the cutting action starts, move the torch tip at a even rate. Avoid unsteady movement of the torch to prevent irregular cuts and premature stopping of the cutting action.

To start a cut quicker in thick plate, you should start at the edge of the metal with the torch angled in the opposite direction of travel. When the edge starts to cut, bring the torch to a vertical position to complete the cut through the total thickness of the metal. As soon as the cut is through the metal, start moving the torch in the direction of travel.

Two other methods for starting cuts are used. In the first method, you nick the edge of the metal with a cold chisel at the point where the cut is to start. The sharp edges of the metal upset by the chisel will preheat and oxidize rapidly under the cutting torch, allowing you to start the cut without preheating the entire edge of the plate. In the second method, you place an iron filler rod at the edge of a thick plate. As you apply the preheat flames to the edge of the plate, the filler rod rapidly reaches the cherry red temperature. At this point, turn the cutting oxygen on and the rod will oxidize and cause the thicker plate to start oxidizing.

## CUTTING CAST IRON

It is more difficult to cut cast iron than steel because the iron oxides in cast iron melt at a higher temperature than the cast iron itself. Before you cut cast iron, it is best to preheat the whole casting to prevent stress fractures. Do not heat the casting to a temperature that is too high, as this will oxidize the surface and make cutting more difficult. A preheat temperature of about 500°F is normally satisfactory.

When cutting cast iron, adjust the preheating flame of the torch to a carburizing flame. This prevents the formation of oxides on the surface and provides better preheat. The cast-iron kerf is always wider than a steel kerf due to the presence of oxides and the torch movement.

The torch movement is similar to scribing semi-circles along the cutting line (fig. 4-22). As the metal becomes molten, trigger the cutting oxygen and use its force to jet the molten metal out of the kerf. Repeat this action until the cut is complete.

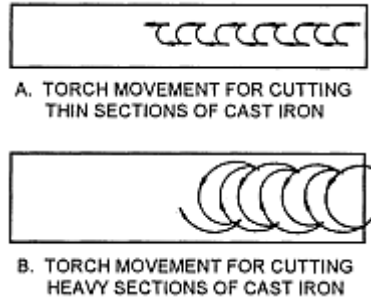


Figure 4-22.—Torch movements for cutting cast iron.

Because of the difficulty in cutting cast iron with the usual oxygas cutting torch, other methods of cut-ting were developed. These include the oxygen lance, carbon-arc powder, inert-gas cutting, and plasma-arc methods.

## GOUGING MILD STEEL

Cutting curved grooves on the edge or surface of a plate and removing faulty welds for rewelding are additional uses for the cutting torch. The gist of groove cutting or gouging is based on the use of a large orifice, low-velocity jet of oxygen instead of a high-velocity jet. The low-velocity jet oxidizes the surface metal only and gives better control for more accurate gouging. By varying the travel speed, oxygen pressure, and the angle between the tip and plate, you can make a variety of gouge contours.

A gouging tip usually has five or six preheat orifices that provide a more even preheat distribution. Automatic machines can cut grooves to exact depths, remove bad spots, and rapidly prepare metal edges for welding.

Figure 4-23 shows a typical gouging operation. If the gouging cut is not started properly, it is possible to cut accidentally through the entire thickness of the plate. If you cut too shallow, you can cause the operation to stop. The travel speed of the torch along the gouge line is important. Moving too fast creates a narrow, shallow gouge and moving too slow creates the opposite; a deep, wide gouge.



Figure 4-23. - Typical gouging operation using a low-velocity

## BEVELING MILD STEEL

Frequently, you must cut bevels on plate or pipe to form joints for welding. The flame must actually cut through 2.8 inches of metal to make a bevel cut of 45 degrees on a 2-inch steel plate. You must take this into consideration when selecting the tip and adjusting the pressures. You use more pressure and less speed for a bevel cut than for a straight cut.

When bevel cutting, you adjust the tip so the pre-heating orifices straddle the cut. A piece of 1-inch angle iron, with the angle up, makes an excellent guide for beveling straight edges. To keep the angle iron in place while cutting, you should use a heavy piece of scrap, or tack-weld the angle to the plate being cut. Move the torch along this guide, as shown in figure 4-24.

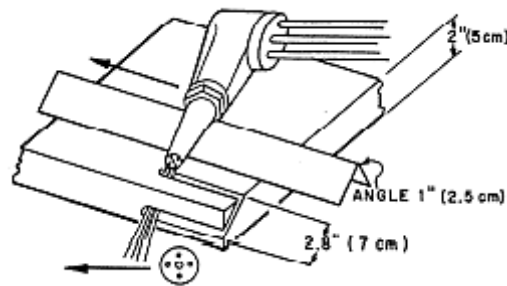


Figure 4-24.—Using angle iron to cut bevels on steel plate

## ELECTRIC DRIVE CUTTING TORCH CARRIAGE

An improvement over mechanical guides is an electric motor-driven cutting torch carriage. The speed of the motor can be varied allowing the welder to cut to dimensions and to cut at a specific speed. A typical motor driven carriage has four wheels: one driven by a reduction gear, two on swivels (castor style), and one freewheeling. The torch is mounted on the side of the carriage and is adjusted up and down by a gear and rack. The rack is a part of the special torch. The torch also can be tilted for bevel cuts. This machine comes with a straight two-groove track and has a radial bar for use in cutting circles and arcs. A motor-driven cutting torch cutting a circle is shown in figure 4-25. The carriage is equipped with an off-and-on switch, a reversing switch, a clutch, and a speed-adjusting dial that is calibrated in feet per minute.



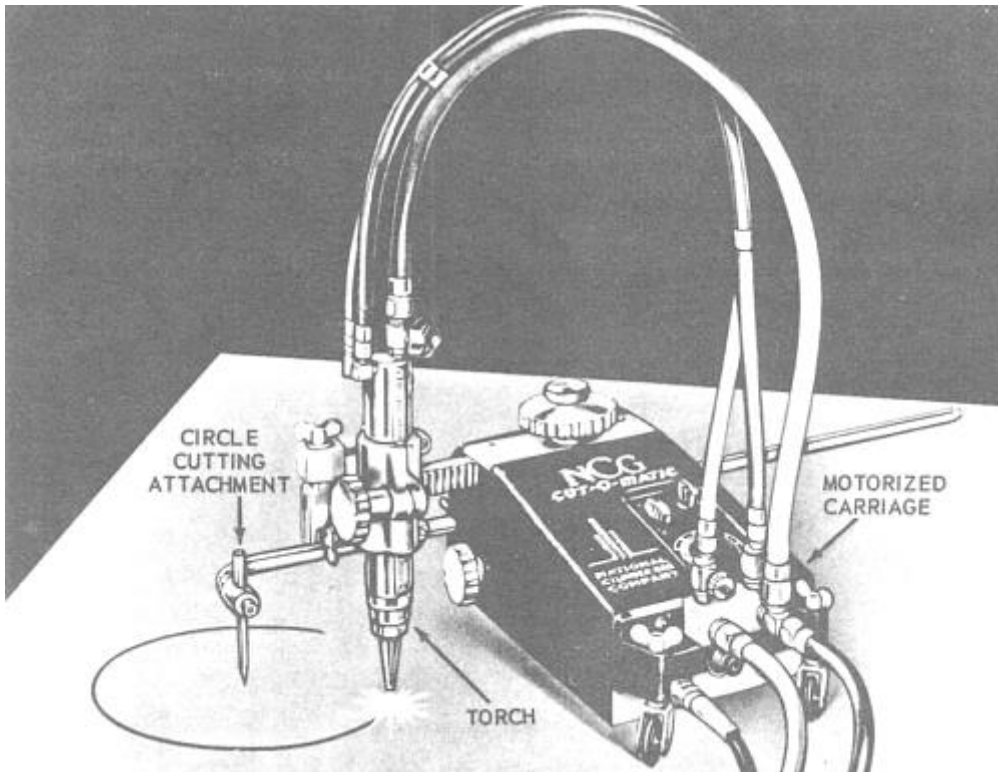


Figure 4-25.—Electric motor-driven carriage being used to cut a circle in steel plate.

Figure 4-26 shows an electric drive carriage on a straight track being used for plate beveling. The operator must ensure that the electric cord and gas hoses do not become entangled on anything during the cutting operation. The best way to check for hose, electric cord, and torch clearance is to freewheel the carriage the full length of the track by hand.

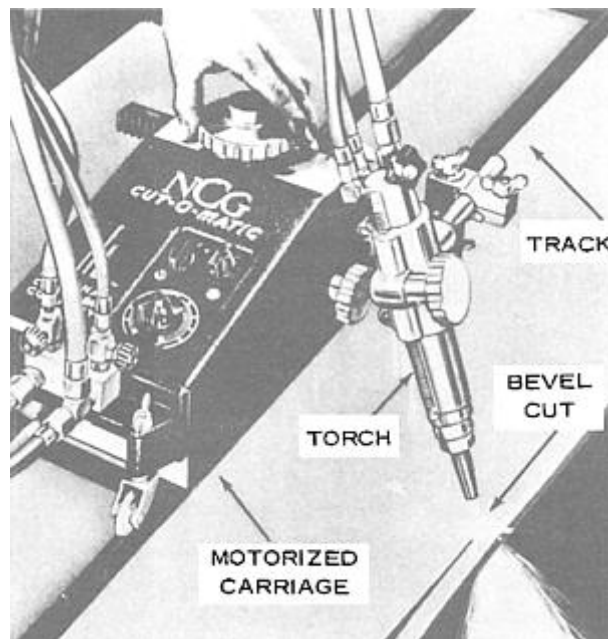


Figure 4-26.—Electric motor-driven carriage being used on straight track to cut a beveled edge on steel plate.

You will find that the torch carriage is a valuable asset during deployment. This is especially true if your shop is called upon to produce a number of identical parts in quantity. Such an

assignment might involve the fabrication of a large supply of hand hole covers for runway fixtures, or another assignment might be the production of a large quantity of thick base plates for vertical columns. When using the torch carriage, you should lay the track in a straight line along a line parallel to the edge of the plate you are going to cut. Next, you light the torch and adjust the flame for the metal you are cutting. Move the carriage so the torch flame preheats the edge of the plate and then open the cutting oxygen valve and turn on the carriage motor. The machine begins moving along the track and continues to cut automatically until the end of the cut is reached. When the cut is complete, you should do the following: promptly turn off the cutting oxygen, turn off the current, and extinguish the flame--in that order. The cutting speed depends upon the thickness of the steel being cut

## CUTTING AND BEVELING PIPE

Pipe cutting with a cutting torch requires a steady hand to obtain a good bevel cut that is smooth and true. Do not attempt to cut and bevel a heavy pipe in one operation until you have developed considerable skill. First, you should cut the pipe off square, and ensure all the slag is removed from the inside of the pipe. Next, you should bevel the pipe. This procedure produces a cleaner and better job; it is ideal for use by an inexperienced welder.

When cutting a piece of pipe, you should keep the torch pointed toward the centre line of the pipe. Start the cut at the top and cut down one side. Then begin at the top again and cut down the other side, finishing at the bottom of the pipe. This procedure is shown in figure 4-27.

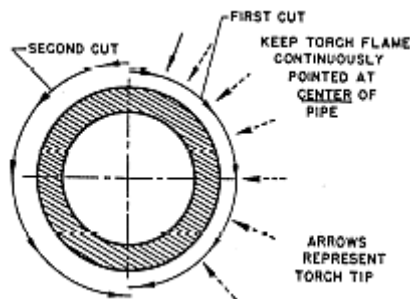


Figure 4-27.—Cutting pipe with an oxygen cutting torch.

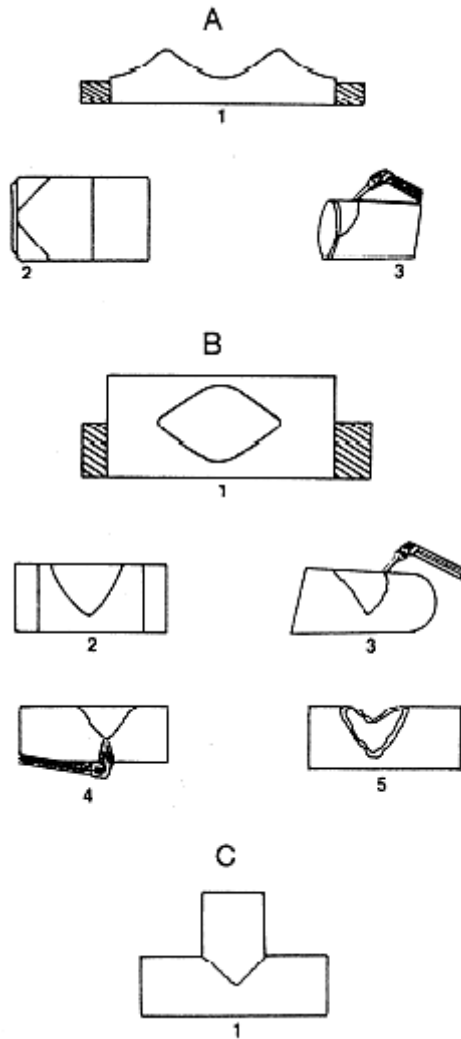


Figure 4-28.—Fabricating a T.

When you make T and Y fittings from pipe, the cutting torch is a valuable tool. The usual procedure for fabricating pipe fittings is to develop a pattern like the one shown in figure 4-28, view A-1.

After you develop the pattern, wrap it around the pipe, as shown in figure 4-28, view A-2. Be sure to leave enough material so the ends overlap. Trace around the pattern with soapstone or a scribe. It is a good idea to mark the outline with a prick punch at 1/4-inch intervals. During the cutting procedure, as the metal is heated, the punch marks stand out and make it easier to follow the line of cut. Place the punch marks so the cutting action will remove them. If punch marks are left on the pipe, they could provide notches from which cracking may start.

An experienced welder can cut and bevel pipe at a 45-degree angle in a single operation. A person with little cutting experience should do the job in two steps. In that case, the first step involves cutting the pipe at a 90-degree angle. In the second step, you bevel the edge of the cut to a 45-degree angle. With the two-step procedure, you must mark an additional line on the pipe. This second line follows the contour of the line traced around the pattern, but it is drawn away from the original pattern line at a distance equal to the thickness of the pipe wall. The first (90-degree) cut in the two-step procedure is made along the second line. The second (45-degree) cut is made along the original pattern line. The primary disadvantage of the two-step procedure is it is time consuming and uneconomical in oxygen and gas consumption.

The one-step method of cutting and bevelling pipe is not difficult, but it does require a steady hand and a great deal of experience to turn out a first-class job. An example of this method for fabricating a T is shown in figure 4-28. View A of figure 4-28 outlines the step-by-step procedures for fabricating the branch; view B shows the steps for preparing the main section of the T; and view C shows the assembled T, tack-welded and ready for final welding.

Step 3 of view A of figure 4-28 shows the procedure for cutting the miter on the branch. You should begin the cut at the end of the pipe and work around until one half of one side is cut. The torch is at a 45-degree angle to the surface of the pipe along the line of cut. While the tip is at a 45-degree angle, you should move the torch steadily forward, and at the same time, swing the butt of the torch upward through an arc. This torch manipulation is necessary to keep the cut progressing in the proper direction with a bevel of 45 degrees at all points on the miter. Cut the second portion of the miter in the same reamer as the first.

The torch manipulation necessary for cutting the run of the T is shown in Steps 3 and 4 of view B in figure 4-28. Step 3 shows the torch angle for the starting cut and Step 4 shows the cut at the lowest point on the pipe. Here you change the angle to get around the sharp curve and start the cut in an upward direction. The completed cut for the run is shown in Step 5 (figure 4-28, view B).

Before final assembly and tack welding of any of the parts of a fabricated fitting, you must clean the slag from the inner pipe wall and check the fit of the joint. The bevels must be smooth and have complete fusion when you weld the joint.

## PIERCING HOLES

The cutting torch is a valuable tool for piercing holes in steel plate. Figure 4-29 shows the steps you should use to pierce holes in steel plate. First, lay the plate out on firebricks or other suitable material so the flame does not damage anything when it burns through the plate. Next, hold the torch over the hole location with the tips of the inner cone of the preheating flames about 1/4 inch above the surface of the plate. Continue to hold the torch in this position until a small spot has been heated to a bright red. Then open the cutting oxygen valve gradually, and at the same time, raise the nozzle slightly away from the plate. As you start raising the torch and opening the oxygen valve, rotate the torch with a slow spiral motion. This causes the molten slag to be blown out of the hole. The hot slag may fly around, so BE SURE that your goggles are tightly fitted to your face, and avoid placing your head directly above the cut.

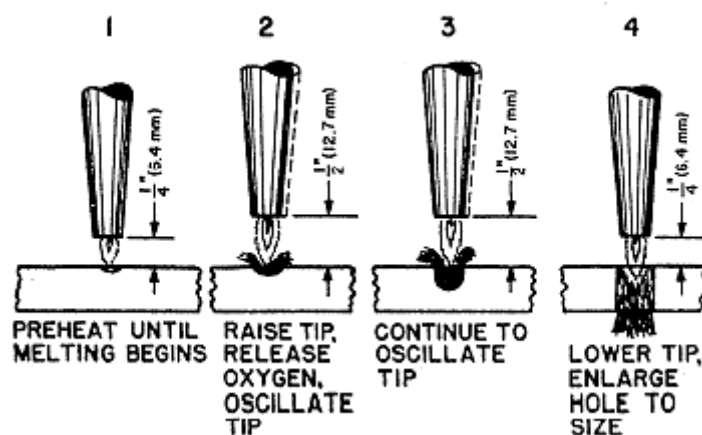


Figure 4-29.—Piercing a hole with an oxygas cutting torch.

If you need a larger hole, outline the edge of the hole with a piece of soapstone, and follow the procedure indicated above. Begin the cut from the hole you pierced by moving the preheating flames to the normal distance from the plate and follow the line drawn on the plate. Round holes are made easily by using a cutting torch with a radius bar attachment.

## CUTTING RIVETS

The cutting torch is an excellent tool for removing rivets from structures to be disassembled. Rivet cutting procedures are shown in figure 4-30. The basic method is to heat the head of the rivet to cutting temperature by using the preheating flames of the cutting torch. When the rivet head is at the proper temperature, turn on the oxygen and wash it off. The remaining portion of the rivet can then be punched out with light hammer blows.

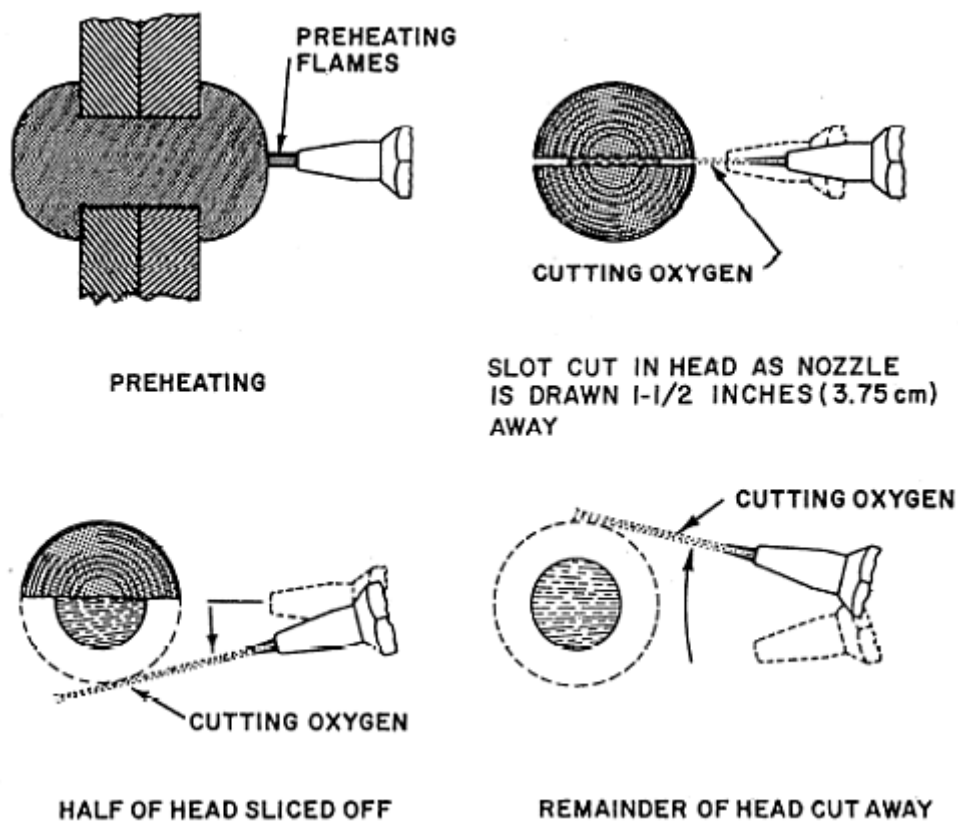


Figure 4-30.—Using a cutting torch to remove a rivet head,

The step-by-step procedure is as follows:

1. Use the size of tip and the oxygen pressure required for the size and type of rivet you are going to cut.
2. Heat a spot on the rivet head until it is bright red.
3. Move the tip to a position parallel with the surface of the plate and turn on the cutting oxygen slowly.
4. Cut a slot in the rivet head like the screwdriver slot in a roundhead screw. When the cut nears the plate, draw the nozzle back at least 1 1/2 inches from the rivet so you do not cut through the plate.
5. When cutting the slot through to the plate, you should swing the tip through a small arc. This slices half of the rivet head off.
6. Swing the tip in an arc in the other direction to slice the other half of the rivet head off.

By the time the slot has been cut, the rest of the rivet rope strands from unlaying during cutting, seize the wire head is at cutting temperature. Just before you get through the slot, draw the torch tip back 1 1/2 inches to allow the cutting oxygen to scatter slightly. This keeps the torch from breaking through the layer of scale that is always present between the rivet head and the plate. It allows you to cut the head of the rivet off without damaging the surface of the plate. If you do not draw the tip away, you could cut through the scale and into the plate.

A low-velocity cutting tip is best for cutting button-head rivets and for removing countersunk rivets. A low-velocity cutting tip has a cutting oxygen orifice with a large diameter. Above this orifice are three preheating orifices. Always place a low-velocity cutting tip in the torch so the heating orifices are above the cutting orifice when the torch is held in the rivet cutting position.

## **CUTTING WIRE ROPE**

You can use a cutting torch to cut wire rope. Wire rope consists of many strands, and since these strands do not form one solid piece of metal, you could experience difficulty in making the cut. To prevent the wire rope on each side of the place where you intend to cut.

Adjust the torch to a neutral flame and make the cut between the seizings. If the wire rope is going to go through sheaves, then you should fuse the strand wires together and point the end. This makes reeving the block much easier, particularly when you are working with a large-diameter wire rope and when reeving blocks that are close together. To fuse and point wire rope, adjust the torch to a neutral flame; then close the oxygen valve until you get a carburizing flame. With proper torch manipulation, fuse the wires together and point the wire rope at the same time.

Wire rope is lubricated during fabrication and is lubricated routinely during its service life. Ensure that all excess lubricant is wiped off the wire rope before you begin to cut it with the oxygen torch.

## **CUTTING ON CONTAINERS**

Never perform cutting or welding on containers that have held a flammable substance until they have been cleaned thoroughly and safeguarded. Cutting, welding, or other work involving heat or sparks on used barrels, drums, tanks, or other containers is extremely dangerous and could lead to property damage or loss of life.

Whenever available, use steam to remove materials that are easily volatile. Washing the containers with a strong solution of caustic soda or a similar chemical will remove heavier oils.

Even after thorough cleansing, the container should be further safeguarded by filling it with water before any cutting, welding, or other hot work is done. In almost every situation, it is possible to position the container so it can be kept filled with water while cutting or other hot work is being done. Always ensure there is a vent or opening in the container for the release of the heated vapor inside the container. This can be done by opening the bung, handhole, or other fitting that is above water level.

When it is practical to fill the container with water, you also should use carbon dioxide or nitrogen in the vessel for added protection. From time to time, examine the gas content of the container to ensure the concentration of carbon dioxide or nitrogen is high enough to prevent a flammable or explosive mixture. The air-gas mixture inside any container can be tested with a suitable gas detector.

The carbon dioxide concentration should be at least 50 percent of the air space inside the container, and 80 percent or more when the presence of hydrogen or carbon monoxide is detected. When using nitrogen, you must ensure the concentration is at least 10 percent higher than that specified for carbon dioxide.

Carbon dioxide or nitrogen is used in apparently clean containers because there may still be traces of oil or grease under the seams, even though the vessel was cleaned and flushed with a caustic soda solution. The heat from the cutting or welding operation could cause the trapped oil or grease to release flammable vapors that form an explosive mixture inside the container.

A metal part that is suspiciously light may be hollow inside; therefore, you should vent the part by drilling a hole in it before heating. Remember: air or any other gas that is confined inside a hollow part will expand when heated. The internal pressure created may be enough to cause the part to burst. Before you do any hot work, take every possible precaution to vent the air confined in jacketed vessels, tanks, or containers.

## **Judging Cutting Quality**

To know how good of a cutting job you are doing, you must understand what constitutes a good oxygas cut. In general, the quality of an oxygas cut is judged by four characteristics:

- The shape and length of the draglines
- The smoothness of the sides
- The sharpness of the top edges
- The amount of slag adhering to the metal

## **DRAG LINES**

Drag lines are line markings that show on the surface of the cut. Good drag lines are almost straight up and down, as shown in figure 4-31, view A. Poor drag lines, as shown in figure 4-31, view B, are long and irregular or curved excessively. Drag lines of this type indicate a poor cutting procedure that could result in the loss of the cut (figure 4-31, views B and C). Draglines are the best single indication of the quality of the cut made with an oxygas torch. When the draglines are short and almost vertical, the sides smooth, and the top edges sharp, you can be assured that the slag conditions are satisfactory.

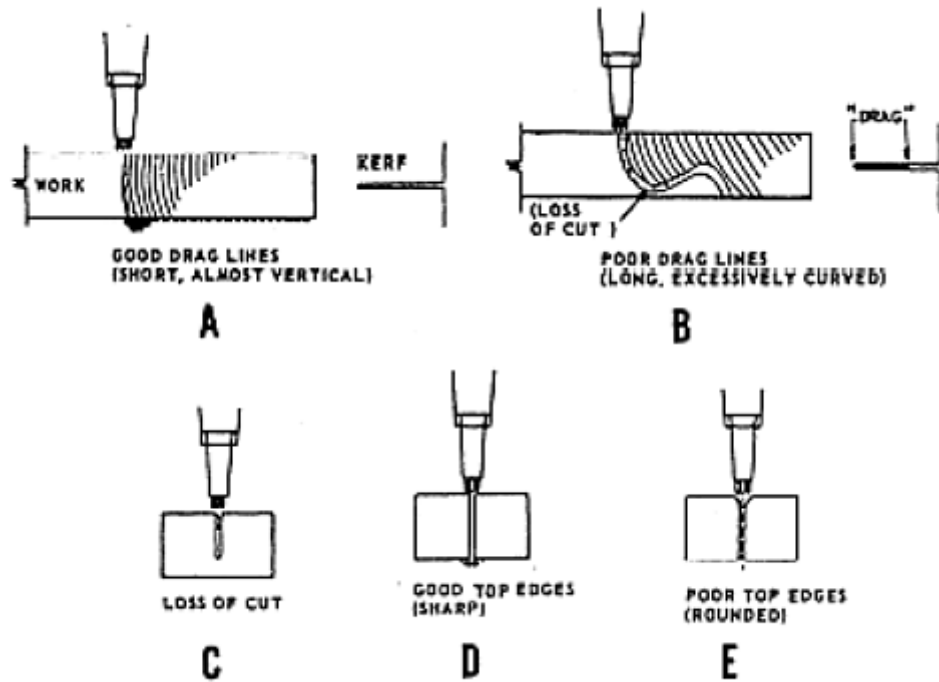


Figure 4-31.—Effects of correct and incorrect cutting procedures.

## SIDE SMOOTHNESS

A satisfactory oxygen cut shows smooth sides. A grooved, fluted, or ragged cut surface is a sign of poor quality.

**TOP EDGE SHARPNESS** The top edges resulting from an oxygen cut should be sharp and square (figure 4-31, view D). Rounded top edges, such as those shown in view E of figure 4-31, are not satisfactory. The melting of the top edges may result from incorrect preheating procedures or from moving the torch too slowly.

## SLAG CONDITIONS

An oxygen cut is not satisfactory when slag adheres so tightly to the metal that it is difficult to remove.

## Safety Precautions

In all cutting operations, you must ensure that hot slag does not come in contact with combustible material. Globules of hot slag can roll along the deck for long distances. Do not cut within 30 to 40 feet of unprotected combustible materials. If you cannot remove the combustible materials, cover them with sheet metal or other flameproof guards. Keep the fuel gas and oxygen cylinders far enough away from the work so hot slag does not fall on the cylinders or hoses.

Many of the safety precautions discussed in other lessons in this course apply to cutting as well as to welding. Be sure you are completely familiar with all the appropriate safety precautions before attempting oxygen cutting operations.



## **BACKFIRE AND FLASHBACK**

Improper operation of the oxygas torch can cause the flame to go out with a loud snap or pop. This is called a "backfire." Close the torch valves, check the connections, and review your operational techniques before relighting the torch. You may have caused the backfire by touching the tip against the work, by overheating the tip, or by operating the torch with incorrect gas pressures. A backfire also may be caused by a loose tip or head or by dirt on the seat.

A flashback occurs when the flame burns back inside the torch, usually with a shrill hissing or squealing noise. You should close the torch oxygen valve that controls the flame to stop the flashback at once. Then you should close the gas valve and the oxygen and gas regulators. Be sure you allow the torch to cool before relighting it. Also, blow oxygen through the cutting tip for a few seconds to clear out soot that may have accumulated in the passages. Flashbacks may extend back into the hose or regulators. Flashbacks indicate that something is wrong, either with the torch or with the way it is being operated. Every flashback should be investigated to determine its cause before the torch is relighted. A clogged orifice or incorrect oxygen and gas pressures are often responsible. Avoid using gas pressures higher than those recommended by the manufacturer.

## **CYLINDERS**

Gas cylinders are made of high-quality steel. High-pressure gases, such as oxygen, hydrogen, nitrogen, and compressed air, are stored in cylinders of seamless construction. Only non-shatterable high-pressure gas cylinders may be used by ships or activities operating outside the continental United States. Cylinders for low-pressure gases, such as acetylene, may be welded or brazed. Cylinders are carefully tested, either by the factory or by a designated processing station, at pressures above the maximum permissible charging pressure.

### **Identification of Cylinders**

Color warnings provide an effective means for marking physical hazards and for indicating the location of safety equipment. Uniform colors are used for marking

compressed-gas cylinders, pipelines carrying hazardous materials, and fire protection equipment.

Five classes of material have been selected to represent the general hazards for dangerous materials, while a sixth class has been reserved for fire protection equipment. A standard color has been chosen to represent each of these classes and is shown in table 4-2.

Table 4-2.—Standard Colors

Class	Standard Color	Class of Material
a	Yellow, No. 13655	<b>FLAMMABLE MATERIALS.</b> All materials known ordinarily as flammables or combustibles. Of the chromatic colors, it has the highest coefficient of reflection under white light and can be recognized under the poorest conditions of illumination.
b	Brown, No. 10080	<b>TOXIC AND POISONOUS MATERIALS.</b> All materials extremely hazardous to life or health under normal conditions as toxics or poisons.
c	Blue, No. 15102	<b>ANESTHETICS AND HARMFUL MATERIALS.</b> All materials productive of anesthetic vapors and all liquid chemicals and compounds hazardous to life and property but not normally productive of dangerous quantities of fumes or vapors.
d	Green, No. 14260	<b>OXIDIZING MATERIALS.</b> All materials which readily furnish oxygen for combustion and fire producers which react explosively or with the evolution of heat in contact with many other materials.
e	Gray, No. 16187	<b>PHYSICALLY DANGEROUS MATERIALS.</b> All materials, not dangerous in themselves, which are asphyxiating in confined areas or which are generally handled in a dangerous physical state of pressure or temperature.
f	Red, No. 11105	<b>FIRE PROTECTION MATERIALS.</b> All materials provided in piping systems or in compressed-gas cylinders exclusively for use in fire protection.

Since you work with fuel gas and oxygen, you must become familiar with the colors of the cylinders in which these gases are contained. The fuel-gas cylinder is yellow, and the oxygen cylinder is green.

In addition to color coding, the exact identification of the material contained in a compressed-gas cylinder must be indicated by a written title that appears in two locations—diametrically opposite and parallel to the longitudinal axis of the cylinder. Cylinders, having a background color of yellow, orange, or buff have the title painted black. Cylinders, having a background color of red, brown, black, blue, gray, or green, have the title painted white.

**COLOR WARNINGS.**— The appearance on the body, top, or as a band(s) on compressed-gas cylinders of the six colors specified should provide a warning of danger from the hazard involved.

**CYLINDER COLOR BANDS.**— Cylinder color bands appear upon the cylinder body and serve as color warnings when they are yellow, brown, blue, green, or gray. The bands also provide color combinations to separate and distinguish cylinders for convenience in handling, storage, and shipping.

**DECALS.**— Two decals may be applied on the shoulder of each cylinder. They should be diametrically opposite and at right angles to the titles. They should indicate the name of the gas, precautions for handling, and use. A background color corresponding to the primary warning color of the contents should be used.

**SHATTERPROOF CYLINDERS.**— A shatter-proof cylinder should be stenciled with the phrase “NON-SHAT” longitudinally 90 degrees from the titles. Letters must be black or white and approximately 1 inch in size.

**SERVICE OWNERSHIP.**— On cylinders owned by or procured for the Department of Defense, the bottom and the lower portion of the cylinder body opposite the valve end may be used for service ownership titles.

The six colors identified in Table 4-2 are used on the body and top of, or as a band on, a compressed-gas cylinder to serve as a warning of the hazard involved in handling the type of material contained in the cylinder.

TITLE	LOCATION ON CYLINDER			
	TOP A	BAND B	BAND C	BODY
ACETYLENE	YELLOW	YELLOW	YELLOW	YELLOW
ARGON, OIL-FREE	GRAY	WHITE	GRAY	GRAY
CARBON DIOXIDE	GRAY	GRAY	GRAY	GRAY
CARBON DIOXIDE ( <i>Fire only</i> )	RED	RED	RED	RED
HELIUM, OIL-TOLERANT	GRAY	ORANGE	GRAY	GRAY
METHYLE ACETYLENE PROPADIENE (MAPP) MIXTURE	YELLOW	ORANGE	YELLOW	YELLOW
OXYGEN	GREEN	GREEN	GREEN	GREEN

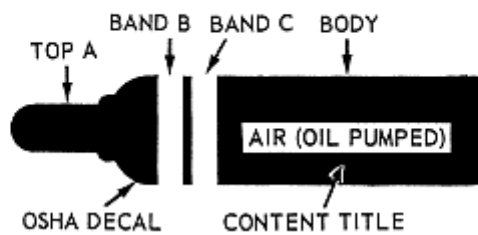


Figure 4-32.—Titles and color codes for compressed-gas cylinders.

Figure 4-32 shows titles and color codes for compressed-gas cylinders most often found on construction sites or in a public works department where welders are working. Figure 4-33 shows how cylinders are identified by the overall painted color code and by the stenciled name of the gas. It should be noted that the color code of cylinders shown in figure 4-32 is military only; the commercial industry does not necessarily comply with these color codes. Commercial U.S. and ISO color-code standards have yet to be established.

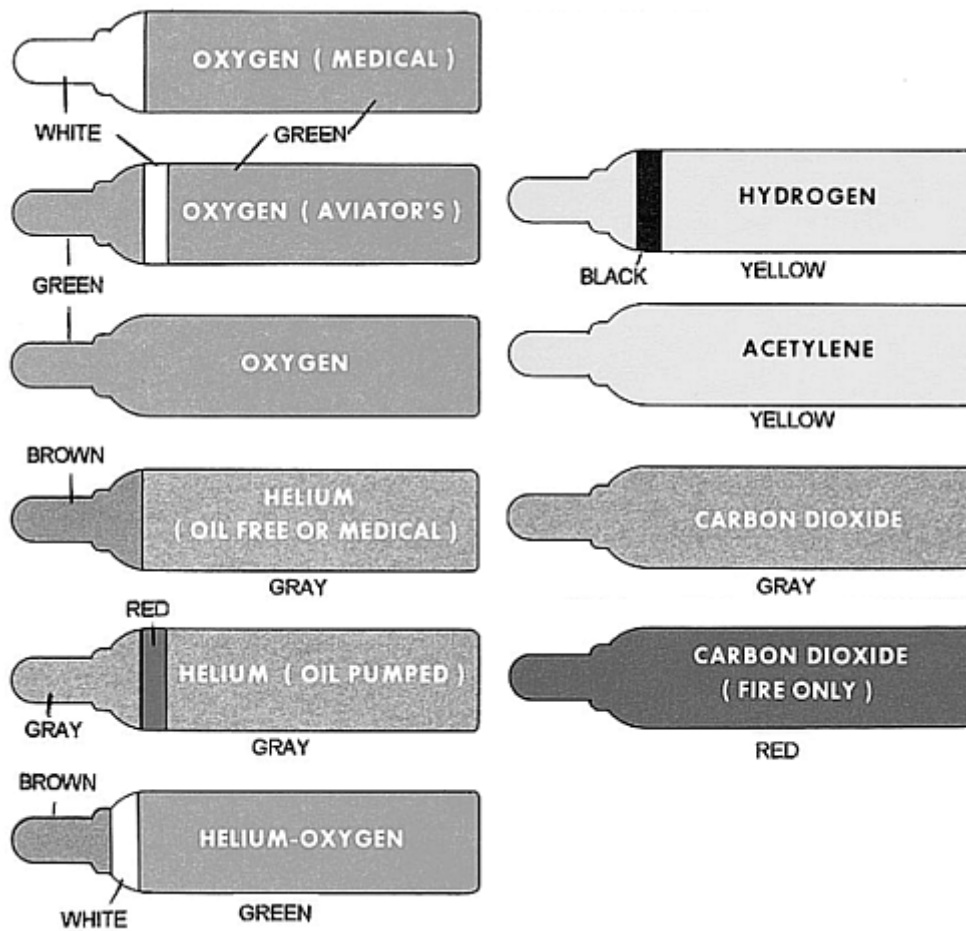


Figure 4-33.—Identifying color patterns for gas cylinders.

## Handling and Storing Gas Cylinders

Each compressed-gas cylinder carries markings indicating compliance with Interstate Commerce Commission (ICC) requirements. When the cylinders are at your work site, they become your responsibility. There are several things you should not do when handling and storing compressed-gas cylinders.

- Never fill your own cylinders. It requires special training and special equipment.
- Never alter or fix the safety devices on a cylinder. It is illegal and also stupid. The only personnel permitted to work on cylinder safety devices are the cylinder owners and suppliers.
- Never store cylinders near a heat source or in direct sunlight. Heat causes the gas inside a cylinder to expand. This could result in cylinder failure or fire.
- Never store cylinders in a closed or unventilated space. If one of the cylinders were to leak, it could cause an explosion or asphyxiate someone entering the space.
- Store cylinders in protected, well-ventilated, and dry spaces. Protect the cylinder valves and safety devices from ice and snow. A safety device may not work if it is frozen.
- Never store fuel cylinders and oxidizers within the same space. Oxidizers must be stored at least 50 feet from fuel cylinders. Use fire-resistant partitions between cylinder storage areas.
- Never mix empty cylinders with full cylinders.
- Do not mix cylinders that contain different gases.
- Always replace the cylinder cap and mark the cylinder "Empty" or "MT." Store the cylinders in a cool, dry place ready for pickup by the supplier. Even in storage, chain the cylinders when they are stored in the upright position.

- Never drag a cylinder to move it. When available, use a cylinder truck. If at all possible, leave the cylinders on the hand truck and operate them from there; otherwise, tilt the cylinder slightly and roll it on the bottom edge. Always install the cylinder cap before moving the cylinder. Never use slings or magnets to carry cylinders. If you lift a cylinder upright by the cap, make sure that it is screwed on tightly. If the cylinder cap comes off, the cylinder could fall and either crush your foot or snap the valve off. If a cylinder is dropped and the valve breaks, it could launch itself like a rocket.

When cylinders have been stored outside in freezing weather, they sometimes become frozen to the ground or to each other. To free the cylinders, you can pour warm water (not boiling) over the frozen or icy areas. As a last resort, you can pry them loose with a prybar. If you use a prybar, never pry or lift under the valve cap or valve.