

RULES FOR  
CLASSIFICATION OF  
**SHIPS**

IACS COMMON STRUCTURAL RULES

PART 8 CHAPTER 2

**COMMON STRUCTURAL RULES FOR  
BULK CARRIERS  
WITH LENGTH 90 METRES AND ABOVE**

JULY 2010

CONTENTS		PAGE
Chapter 1	General Principles.....	7
Chapter 2	General Arrangement Design .....	29
Chapter 3	Structural Design Principles .....	49
Chapter 4	Design Loads .....	101
Chapter 5	Hull Girder Strength .....	169
Chapter 6	Hull Scantlings .....	197
Chapter 7	Direct Strength Analysis.....	267
Chapter 8	Fatigue Check of Structural Details.....	297
Chapter 9	Other Structures .....	333
Chapter 10	Hull Outfitting .....	399
Chapter 11	Construction and Testing.....	451
Chapter 12	Additional Class Notations .....	467
Chapter 13	Ships in Operation, Renewal Criteria .....	471

DET NORSKE VERITAS

Veritasveien 1, NO-1322 Høvik, Norway Tel.: +47 67 57 99 00 Fax: +47 67 57 99 11

# CHANGES IN THE RULES

## General

The present edition of the rules includes additions and amendments decided by the executive committee as of June 2010, and supersedes the July 2009 edition of the same chapter, including later amendments.

The following Rule Change Notices have been incorporated:

- Rule Change Notice 1 (Coming into force 1 April 2008)
- Rule Change Notice 2 (Coming into force 1 July 2008)
- Rule Change Notice 3 (Coming into force 1 January 2009)
- Rule Change Notice 1 to the consolidated July 2008 IACS edition (Coming into force 1 July 2009)
- Rule Change Notice 2 (Coming into force 1 July 2010).

The following Corrigendas have been incorporated:

- Corrigenda 1 (May 2006)
- Corrigenda 2 (January 2007)
- Corrigenda 3 (July 2007)
- Corrigenda 4 (September 2007)
- Corrigenda 5 (May 2008).

The incorporated Rule Change Notices and corrigendas may be obtained from (<http://www.iacs.org.uk/publications/>).

## Main changes July 2010 (Rule Change Notice 2)

### Coming into force 1 July 2010

#### • Chapter 1 Sec.3 Functional Requirements

- Item 2.5.1 is aligned with SOLAS II-1/3-6, the requirement is to be applied to bulk carriers of 20 000 gross tonnage and above.

#### • Chapter 1 Sec.4 Symbols and Definitions

- In item 3.7.1 the definition of lightweight is aligned with the definition in the Reg.3.22 Chapter II-1 of SOLAS.

#### • Chapter 2 Sec.3 Access Arrangement

- A new Sub-section 1.0 Application has been added, stating that the requirements in whole Sec.3 shall be applied to bulk carriers of 20 000 gross tonnage and above.

#### • Chapter 3 Sec.1 Material

- Item 2.3.1 has been aligned with IACS UR Rev.5.
- Item 2.3.4 has been deleted as the requirement is not applicable to bulk carriers.
- In item 2.3.9 the applicable role products welded attachment is clarified to that with length more than  $0.15L$  and fitted to outside of hull plating.

#### • Chapter 3 Sec.6 Structural Arrangements Principles

- The application of 9.5.4 is added, referring to those ships having the additional class notation **GRAB[X]**.

#### • Chapter 4 Sec.5 External Pressures

- Table 4 is aligned with the text in the amended ILLC and IACS UR S21. The definition of the distance “ $x$ ” is modified and replaced by the new distance “ $x_{LL}$ ” which is measured from the aft end of freeboard length  $L_{LL}$ .
- In Table 5 pressure on forecastle deck is adjusted by a reduction factor of 0.75.

#### • Chapter 4 App.1 Hold Mass Curves

- The Appendix is revised to clarify the requirements corresponding to each class notation.

#### • Chapter 9 Sec.4 Superstructures and Deckhouses

- In item 3.2.1 the pressure for non-exposed decks of superstructures and deckhouses is introduced with a value of  $5 \text{ kN/m}^2$ .

#### • Chapter 9 Sec.5 Hatch Covers

- In item 7.3.5 “Gross cross area” of securing devices is corrected to “net cross area”.

The electronic pdf version of this document found through <http://www.dnv.com> is the officially binding version  
© Det Norske Veritas

Any comments may be sent by e-mail to [rules@dnv.com](mailto:rules@dnv.com)

For subscription orders or information about subscription terms, please use [distribution@dnv.com](mailto:distribution@dnv.com)  
Computer Typesetting (Adobe Frame Maker) by Det Norske Veritas

If any person suffers loss or damage which is proved to have been caused by any negligent act or omission of Det Norske Veritas, then Det Norske Veritas shall pay compensation to such person for his proved direct loss or damage. However, the compensation shall not exceed an amount equal to ten times the fee charged for the service in question, provided that the maximum compensation shall never exceed USD 2 million.  
In this provision “Det Norske Veritas” shall mean the Foundation Det Norske Veritas as well as all its subsidiaries, directors, officers, employees, agents and any other acting on behalf of Det Norske Veritas.

- **Chapter 10 Sec.1 Rudder and Manoeuvring Arrangement**

- Item 1.3 and the first sentence of item 1.1.1 are deleted to avoid any misleading use of the Area Recommendation formula.

- **Chapter 11 Sec.1 Construction**

- Item 1.2.1 and Table 1 are amended to be in line with the Revision 4 of IACS Recommendation No.47.

- **Chapter 11 Sec.2 Welding**

- Tables 1 and 2 have been amended for clarification.

**DNV specific changes July 2010:**

- Structure and layout have been aligned with IACS common structural rules to avoid confusion.

## CONTENTS

### Chapter 1

<b>General Principles .....</b>	<b>7</b>
Sec. 1 Application .....	9
Sec. 2 Verification of Compliance .....	13
Sec. 3 Functional Requirements.....	16
Sec. 4 Symbols and Definitions .....	19

### Chapter 2

<b>General Arrangement Design .....</b>	<b>29</b>
Sec. 1 Subdivision Arrangement.....	31
Sec. 2 Compartment Arrangement.....	35
Sec. 3 Access Arrangement .....	40

### Chapter 3

<b>Structural Design Principles .....</b>	<b>49</b>
Sec. 1 Material .....	51
Sec. 2 Net Scantling Approach .....	60
Sec. 3 Corrosion Additions .....	63
Sec. 4 Limit States .....	65
Sec. 5 Corrosion Protection .....	67
Sec. 6 Structural Arrangement Principles .....	70

### Chapter 4

<b>Design Loads .....</b>	<b>101</b>
Sec. 1 General .....	103
Sec. 2 Ship Motions and Accelerations .....	104
Sec. 3 Hull Girder Loads.....	107
Sec. 4 Load Cases .....	112
Sec. 5 External Pressures .....	115
Sec. 6 Internal Pressures and Forces .....	126
Sec. 7 Loading Conditions .....	136
Sec. 8 Loading Manual and Loading Instrument.....	142
App. 1 Hold Mass Curves .....	147
App. 2 Standard Loading Condition for Direct Strength Analysis .....	155
App. 3 Standard Loading Condition for fatigue assessment.....	166

### Chapter 5

<b>Hull Girder Strength .....</b>	<b>169</b>
Sec. 1 Yielding Check.....	171
Sec. 2 Ultimate Strength Check .....	182
App. 1 Hull Girder Ultimate Strength.....	184

### Chapter 6

<b>Hull Scantlings .....</b>	<b>197</b>
Sec. 1 Plating.....	199
Sec. 2 Ordinary Stiffeners .....	211
Sec. 3 Buckling and Ultimate Strength of Ordinary Stiffeners and Stiffened Panels.....	230
Sec. 4 Primary Supporting Members .....	248
App. 1 Buckling and Ultimate Strength .....	261

<b>Chapter 7</b>	
<b>Direct Strength Analysis .....</b>	<b>267</b>
Sec. 1 Direct Strength Assessment of the Primary Supporting Members .....	269
Sec. 2 Global strength FE analysis of cargo hold structures.....	271
Sec. 3 Detailed Stress Assessment.....	279
Sec. 4 Hot Spot Stress Analysis for Fatigue Strength Assessment.....	283
App. 1 longitudinal Extent of the Finite Element Models .....	289
App. 2 Displacement Based Buckling Assessment in Finite Element Analysis.....	291
<b>Chapter 8</b>	
<b>Fatigue Check of Structural Details .....</b>	<b>297</b>
Sec. 1 General Consideration.....	299
Sec. 2 Fatigue Strength Assessment .....	301
Sec. 3 Stress Assessment of Primary Members .....	306
Sec. 4 Stress Assessment Of Stiffeners .....	309
Sec. 5 Stress Assessment of Hatch Corners.....	322
App. 1 Cross Sectional Properties For Torsion.....	325
<b>Chapter 9</b>	
<b>Other Structures .....</b>	<b>333</b>
Sec. 1 Fore Part.....	335
Sec. 2 Aft Part.....	345
Sec. 3 Machinery Space.....	352
Sec. 4 Superstructures and Deckhouses.....	358
Sec. 5 Hatch Covers.....	363
Sec. 6 Arrangement of Hull and Superstructure Openings.....	385
<b>Chapter 10</b>	
<b>Hull Outfitting .....</b>	<b>399</b>
Sec. 1 Rudder and Manoeuvring Arrangement.....	401
Sec. 2 Bulwarks and Guard Rails.....	435
Sec. 3 Equipment .....	438
<b>Chapter 11</b>	
<b>Construction and Testing .....</b>	<b>451</b>
Sec. 1 Construction .....	453
Sec. 2 Welding.....	455
Sec. 3 Testing of Compartments.....	462
<b>Chapter 12</b>	
<b>Additional Class Notations .....</b>	<b>467</b>
Sec. 1 <b>GRAB</b> Additional Class Notation.....	469
<b>Chapter 13</b>	
<b>Ships in Operation, Renewal Criteria .....</b>	<b>471</b>
Sec. 1 Maintenance of Class .....	473
Sec. 2 Thickness Measurements and Acceptance Criteria.....	474



# Chapter 1

## General Principles

---

Section 1 Application

Section 2 Verification of Compliance

Section 3 Functional Requirements

Section 4 Symbols and Definitions





## SECTION 1 APPLICATION

### 1 General

#### 1.1 Structural requirements

##### 1.1.1

These Rules apply to ships classed with the Society and contracted for construction on or after 1 April 2006.

Note: The “contracted for construction” means the date on which the contract to build the ship is signed between the prospective owner and the shipbuilder. For further details regarding the date of “contracted for construction”, refer to IACS Procedural Requirement (PR) No.29.

##### 1.1.2

These Rules apply to the hull structures of single side skin and double side skin bulk carriers with unrestricted worldwide navigation, having length  $L$  of 90 m or above.

With bulk carrier is intended sea going self-propelled ships which are constructed generally with single deck, double bottom, hopper side tanks and topside tanks and with single or double side skin construction in cargo length area and intended primarily to carry dry cargoes in bulk, excluding ore and combination carriers.

Hybrid bulk carriers, where at least one cargo hold is constructed with hopper tank and topside tank, are covered by the present Rules. The structural strength of members in holds constructed without hopper tank and/or topside tank is to comply with the strength criteria defined in the Rules.

##### 1.1.3

The present Rules contain the IACS requirements for hull scantlings, arrangements, welding, structural details, materials and equipment applicable to all types of bulk carriers having the following characteristics:

- $L < 350$  m
- $L / B > 5$
- $B / D < 2.5$
- $C_B \geq 0.6$

##### 1.1.4

The Rule requirements apply to welded hull structures made of steel having characteristics complying with requirements in Ch 3, Sec 1. The requirements apply also to welded steel ships in which parts of the hull, such as superstructures or small hatch covers, are built in material other than steel, complying with requirements in Ch 3, Sec 1.

##### 1.1.5

Ships whose hull materials are different than those given in [1.1.4] and ships with novel features or unusual hull design are to be individually considered by the Society, on the basis of the principles and criteria adopted in the present Rules.

##### 1.1.6

The scantling draught considered when applying the present Rules is to be not less than that corresponding to the assigned freeboard.

##### 1.1.7

Where scantlings are obtained from direct calculation procedures which are different from those specified in Ch 7, adequate supporting documentation is to be submitted to the Society, as detailed in Sec 2.

#### 1.2 Limits of application to lifting appliances

##### 1.2.1

The fixed parts of lifting appliances, considered as an integral part of the hull, are the structures permanently connected by welding to the ship's hull (for instance crane pedestals, masts, king posts, derrick heel seatings, etc., excluding cranes, derrick booms, ropes, rigging accessories, and, generally, any dismountable parts), only

for that part directly interacting with the hull structure. The shrouds of masts embedded in the ship's structure are considered as fixed parts.

### **1.2.2**

The fixed parts of lifting appliances and their connections to the ship's structure may be covered by the Society's Standard for Certification No. 2.22 "Lifting Appliances", and / or by the certification (especially the issuance of the Cargo Gear Register) of lifting appliances when required.

### **1.2.3**

The design of the structure supporting fixed lifting appliances and the structure that might be called to support a mobile appliance should be designed taking into account the additional loads that will be imposed on them by the operation of the appliance as declared by the shipbuilder or its sub-contractors.

## **1.3 Limits of application to welding procedures**

### **1.3.1**

The requirements of the present Rules apply also for the preparation, execution and inspection of welded connections in hull structures.

They are to be complemented by the general requirements relevant to fabrication by welding and qualification of welding procedures given by the Society when deemed appropriate by the Society.

## **2 Rule application**

### **2.1 Ship parts**

#### **2.1.1 General**

For the purpose of application of the present Rules, the ship is considered as divided into the following three parts:

- fore part
- central part
- aft part.

#### **2.1.2 Fore part**

The fore part includes the structures located forward of the collision bulkhead, i.e.:

- the fore peak structures
- the stem.

In addition, it includes:

- the reinforcements of the flat bottom forward area
- the reinforcements of the bow flare area.

#### **2.1.3 Central part**

The central part includes the structures located between the collision bulkhead and the after peak bulkhead.

Where the flat bottom forward area or the bow flare area extend aft of the collision bulkhead, they are considered as belonging to the fore part.

#### **2.1.4 Aft part**

The aft part includes the structures located aft of the after peak bulkhead.

## 2.2 Rules applicable to various ship parts

### 2.2.1

The various chapters and sections are to be applied for the scantling of ship parts according to Table 1.

Part	Applicable Chapters and Sections	
	General	Specific
Fore part	Ch 1	Ch 9, Sec 1
Central part	Ch 2 Ch 3 Ch 4 Ch 5 Ch 9 <sup>(1)</sup> , excluding: Ch 9, Sec 1 Ch 9, Sec 2	Ch 6 Ch 7 Ch 8
Aft part	Ch 11	Ch 9, Sec 2

(1) See also [2.3].

## 2.3 Rules applicable to other ship items

### 2.3.1

The various Chapters and Sections are to be applied for the scantling of other ship items according to Table 2.

Item	Applicable Chapters and Sections
Machinery spaces	Ch 9, Sec 3
Superstructures and deckhouses	Ch 9, Sec 4
Hatch covers	Ch 9, Sec 5
Hull and superstructure openings	Ch 9, Sec 6
Rudders	Ch 10, Sec 1
Bulwarks and guard rails	Ch 10, Sec 2
Equipment	Ch 10, Sec 3

## 3 Class Notations

### 3.1 Additional service features **BC-A**, **BC-B** and **BC-C**

#### 3.1.1

The following requirements apply to ships, as defined in [1.1.2], having length  $L$  of 150 m or above.

#### 3.1.2

Bulk carriers are to be assigned one of the following additional service features:

- BC-A**: for bulk carriers designed to carry dry bulk cargoes of cargo density 1.0 t/m<sup>3</sup> and above with specified holds empty at maximum draught in addition to **BC-B** conditions.
- BC-B**: for bulk carriers designed to carry dry bulk cargoes of cargo density of 1.0 t/m<sup>3</sup> and above with all cargo holds loaded in addition to **BC-C** conditions.
- BC-C**: for bulk carriers designed to carry dry bulk cargoes of cargo density less than 1.0 t/m<sup>3</sup>.

#### 3.1.3

The following additional service features are to be provided giving further detailed description of limitations to be observed during operation as a consequence of the design loading condition applied during the design in the following cases:

- {maximum cargo density (in t/m<sup>3</sup>)} for additional service features **BC-A** and **BC-B** if the maximum cargo density is less than 3.0 t/m<sup>3</sup> (see also Ch 4, Sec 7, [2.1]).
- {no MP} for all additional service features when the ship has not been designed for loading and unloading in multiple ports in accordance with the conditions specified in Ch 4, Sec 7, [3.3].
- {allowed combination of specified empty holds} for additional service feature **BC-A** (see also Ch 4, Sec 7, [2.1]).

### **3.2 Additional class notation GRAB [X]**

#### **3.2.1 Application**

The additional class notation **GRAB [X]** is mandatory for ships having one of the additional service features **BC-A** or **BC-B**, according to [3.1.2]. For these ships the requirements for the **GRAB [X]** notation given in Ch 12, Sec 1 are to be complied with for an unladen grab weight X equal to or greater than 20 tons.

For all other ships the additional class notation **GRAB [X]** is voluntary.

### **3.3 Class notation CSR**

#### **3.3.1 Application**

In addition to the class notations granted by the assigning Society and to the service features and additional class notations defined hereabove, ships fully complying with the present Rules will be assigned the notation **CSR**.

## **SECTION 2 VERIFICATION OF COMPLIANCE**

### **1 General**

#### **1.1 New buildings**

##### **1.1.1**

For new buildings, the plans and documents submitted for approval, as indicated in [2], are to comply with the applicable requirements in Ch 1 to Ch 12 of the present Rules, taking account of the relevant criteria, as the additional service features and classification notation assigned to the ship or the ship length.

##### **1.1.2**

When a ship is surveyed by the Society during construction, the Society:

- approves the plans and documentation submitted as required by the Rules
- proceeds with the appraisal of the design of materials and equipment used in the construction of the ship and their inspection at works
- carries out surveys or obtains appropriate evidence to satisfy itself that the scantlings and construction meet the rule requirements in relation to the approved drawings
- attends tests and trials provided for in the Rules
- assigns the construction mark.

##### **1.1.3**

The Society defines in specific Rules which materials and equipment used for the construction of ships built under survey are, as a rule, subject to appraisal of their design and to inspection at works, and according to which particulars.

##### **1.1.4**

As part of his interventions during the ship's construction, the Surveyor will:

- conduct an overall examination of the parts of the ship covered by the Rules
- examine the construction methods and procedures when required by the Rules
- check selected items covered by the rule requirements
- attend tests and trials where applicable and deemed necessary.

#### **1.2 Ships in service**

##### **1.2.1**

For ships in service, the requirements in Ch 13 of the present Rules are to be complied with.

### **2 Documentation to be submitted**

#### **2.1 Ships surveyed by the Society during the construction**

##### **2.1.1 Plans and documents to be submitted for approval**

The plans and documents to be submitted to the Society for approval are listed in Table 1. In addition, the Society may request for approval or information, other plans and documents deemed necessary for the review of the design.

Structural plans are to show details of connections of the various parts and are to specify the design materials, including, in general, their manufacturing processes, welding procedures and heat treatments. See also Ch 11, Sec 2, [1.4].

##### **2.1.2 Plans and documents to be submitted for information**

In addition to those in [2.1.1], the following plans and documents are to be submitted to the Society for information:

- general arrangement

- capacity plan, indicating the volume and position of the centre of gravity of all compartments and tanks
- lines plan
- hydrostatic curves
- lightweight distribution
- docking plan.

In addition, when direct calculation analyses are carried out by the Designer according to the rule requirements, they are to be submitted to the Society (see [3]).

## 2.2 Ships for which the Society acts on behalf of the relevant Administration

### 2.2.1 Plans and documents to be submitted for approval

The plans required by the National Regulations concerned are to be submitted to the Society for approval, in addition to those in [2.1].

<b>Table 1 Plans and documents to be submitted for approval</b>	
<i>Plan or document</i>	<i>Containing also information on</i>
Midship section	Class characteristics
Transverse sections	Main dimensions
Shell expansion	Minimum ballast draught
Decks and profiles	Frame spacing
Double bottom	Contractual service speed
Pillar arrangements	Density of cargoes
Framing plan	Design loads on decks and double bottom
Deep tank and ballast tank bulkheads, wash bulkheads	Steel grades
	Corrosion protection
	Openings in decks and shell and relevant compensations
	Boundaries of flat areas in bottom and sides
	Details of structural reinforcements and/or discontinuities
	Bilge keel with details of connections to hull structures
Watertight subdivision bulkheads	Openings and their closing appliances, if any
Watertight tunnels	
Fore part structure	
Aft part structure	
Machinery space structures	Type, power and rpm of propulsion machinery
Foundations of propulsion machinery and boilers	Mass and centre of gravity of machinery and boilers
Superstructures and deckhouses	Extension and mechanical properties of the aluminium alloy used
Machinery space casing	(where applicable)
Hatch covers and hatch coamings	Design loads on hatch covers
	Sealing and securing arrangements, type and position of locking bolts
	Distance of hatch covers from the summer load waterline and from the fore end
Transverse thruster, if any, general arrangement, tunnel structure, connections of thruster with tunnel and hull structures	
Bulwarks and freeing ports	Arrangement and dimensions of bulwarks and freeing ports on the freeboard deck and superstructure deck
Windows and side scuttles, arrangements and details	
Scuppers and sanitary discharges	
Rudder and rudder horn <sup>(1)</sup>	Maximum ahead service speed
Sternframe or sternpost, sterntube	
Propeller shaft boss and brackets <sup>(1)</sup>	
Plan of watertight doors and scheme of relevant manoeuvring devices	Manoeuvring devices
	Electrical diagrams of power control and position indication circuits
Plan of outer doors and hatchways	
Derricks and cargo gear	Design loads (forces and moments)
Cargo lift structures	Connections to the hull structures
Sea chests, stabiliser recesses, etc.	
Hawse pipes	

<b>Table 1 Plans and documents to be submitted for approval (Continued)</b>	
<i>Plan or document</i>	<i>Containing also information on</i>
Plan of manholes	
Plan of access to and escape from spaces	
Plan of ventilation	Use of spaces and location and height of air vent outlets of various compartments
Plan of tank testing	Testing procedures for the various compartments Height of pipes for testing
Loading manual and loading instruments	Loading conditions as defined in Ch 4, Sec 7 (see also Ch 4, Sec 8)
Equipment number calculation	Geometrical elements for calculation List of equipment Construction and breaking load of steel wires Material, construction, breaking load and relevant elongation of synthetic ropes
(1) Where other steering or propulsion systems are adopted (e.g. steering nozzles or azimuth propulsion systems), the plans showing the relevant arrangement and structural scantlings are to be submitted. For azimuth propulsion systems, see Ch 10, Sec 1, [11].	

### 3 Computer programs

#### 3.1 General

##### 3.1.1

In order to increase the flexibility in the structural design direct calculations with computer programs are acceptable (see Ch 7). The aim of such analyses is to assess the structure compliance with the rule requirements.

#### 3.2 General programs

##### 3.2.1

The choice of computer programs according to currently available technology is free. The programs are to be able to manage the model and load cases as required in Ch 7 and/or Ch 8. The programs may be checked by the Society through comparative calculations with predefined test examples. A generally valid approval for a computer program is, however, not given by the Society.

##### 3.2.2

Direct calculations may be used in the following fields:

- global strength
- longitudinal strength
- beams and grillages
- detailed strength.

##### 3.2.3

For such calculation the computer model, the boundary condition and load cases are to be agreed upon with the Society.

The calculation documents are to be submitted including input and output. During the examination it may prove necessary that the Society performs independent comparative calculations.

## **SECTION 3**

### **FUNCTIONAL REQUIREMENTS**

#### **1 General**

##### **1.1 Application**

###### **1.1.1**

This section defines the set of requirements relevant to the functions of the ship structures to be complied with during design and construction, to meet the following objectives.

##### **1.2 Design life**

###### **1.2.1**

The ship is to remain safe and environment-friendly, if properly operated and maintained, for her expected design life, which, unless otherwise specifically stated, is assumed to be equal to 25 years. The actual ship life may be longer or shorter than the design life, depending on the actual conditions and maintenance of the ship, taking into account aging effects, in particular fatigue, coating deterioration, corrosion, wear and tear.

##### **1.3 Environmental conditions**

###### **1.3.1**

The ship's structural design is to be based on the assumption of trading in the North Atlantic environment for the entire design life. Hence the respective wave conditions, i.e. the statistical wave scatter takes into account the basic principle for structural strength layout.

##### **1.4 Structural safety**

###### **1.4.1**

The ship is to be designed and constructed, and subsequently operated and maintained by its builders and operators, to minimise the risk for the safety of life at sea and the pollution of the marine environment as the consequence of the total loss of the ship due to structural collapse and subsequent flooding, loss of watertight integrity.

##### **1.5 Structural accessibility**

###### **1.5.1**

The ship is to be designed and constructed to provide adequate means of access to all spaces and internal structures to enable overall and close-up inspections and thickness measurements.

##### **1.6 Quality of construction**

###### **1.6.1**

As an objective, ships are to be built in accordance with controlled quality production standards using approved materials as necessary.

#### **2 Definition of functional requirements**

##### **2.1 General**

###### **2.1.1**

The functional requirements relevant to the ship structure are indicated in [2.2] to [2.6].

##### **2.2 Structural strength**

###### **2.2.1**

Ships are to be designed to withstand, in the intact condition, the environmental conditions during the design



life, for the appropriate loading conditions. Structural strength is to be determined against buckling and yielding. Ultimate strength calculations have to include ultimate hull girder capacity and ultimate strength of plates and stiffeners.

#### **2.2.2**

Ships are to be designed to have sufficient reserve strength to withstand the wave and internal loads in damaged conditions that are reasonably foreseeable, e.g. collision, grounding or flooding scenarios. Residual strength calculations are to take into account the ultimate reserve capacity of the hull girder, considering permanent deformation and post-buckling behaviour.

#### **2.2.3**

Ships are to be assessed according to the expected design fatigue life for representative structural details.

### **2.3 Coating**

#### **2.3.1**

Coating, where required, is to be selected as a function of the declared use of the ship spaces, e.g. holds, tanks, cofferdams, etc., materials and application of other corrosion prevention systems, e.g. cathodic protection or other alternative means. The protective coating systems, applied and maintained in accordance with manufacturer's specifications concerning steel preparation, coating selection, application and maintenance, are to comply with the SOLAS requirements, the flag administration requirements and the Owner specifications.

### **2.4 Corrosion addition**

#### **2.4.1**

The corrosion addition to be added to the net scantling required by structural strength calculations is to be adequate for the operating life. The corrosion addition is to be assigned in accordance with the use and exposure of internal and external structure to corrosive agents, such as water, cargo or corrosive atmosphere, in addition to the corrosion prevention systems, e.g. coating, cathodic protection or by alternative means.

### **2.5 Means of access**

#### **2.5.1**

Ship structures subject to overall and close-up inspection and thickness measurements are to be provided with means capable of ensuring safe access to the structures. The means of access are to be described in a Ship Structure Access Manual for bulk carriers of 20 000 gross tonnage and over.

Reference is made to SOLAS, Chapter II-1, Regulation 3-6.

### **2.6 Construction quality procedures**

#### **2.6.1**

Specifications for material manufacturing, assembling, joining and welding procedures, steel surface preparation and coating are to be included in the ship construction quality procedures.

## **3 Other regulations**

### **3.1 International regulations**

#### **3.1.1**

Attention of designers, shipbuilders and shipowners of ships covered by these Rules is drawn on the following: Ships are designed, constructed and operated in a complex regulatory framework prescribed internationally by IMO and implemented by flag states or by classification societies on their behalf. Statutory requirements set the standard for statutory aspects of ships such as life saving, subdivisions, stability, fire protection, etc.

These requirements influence the operational and cargo carrying arrangements of the ship and therefore may affect its structural design.

The main international instruments normally to be applied with regard to the strength of bulk carriers are:

— International Convention for Safety of Life at Sea (SOLAS)

— International Convention on Load Lines.

## **3.2 National regulations**

### **3.2.1**

Attention is drawn on the applicable national flag state regulations.

Compliance with these regulations of national administrations is not conditional for class assignment.

## **4 Workmanship**

### **4.1 Requirements to be complied with by the manufacturer**

#### **4.1.1**

The manufacturing plant is to be provided with suitable equipment and facilities to enable proper handling of the materials, manufacturing processes, structural components, etc.

The manufacturing plant is to have at its disposal sufficiently qualified personnel. The Society is to be advised of the names and areas of responsibility of the supervisory and control personnel in charge of the project.

### **4.2 Quality control**

#### **4.2.1**

As far as required and expedient, the manufacturer's personnel has to examine all structural components both during manufacture and on completion, to ensure that they are complete, that the dimensions are correct and that workmanship is satisfactory and meets the standard of good shipbuilding practice.

Upon inspection and corrections by the manufacturing plant, the structural components are to be shown to the surveyor of the Society for inspection, in suitable sections, normally in unpainted condition and enabling proper access for inspection.

The Surveyor may reject components that have not been adequately checked by the plant and may demand their re-submission upon successful completion of such checks and corrections by the plant.

## **5 Structural Details**

### **5.1 Details in manufacturing documents**

#### **5.1.1**

Significant details concerning quality and functional ability of the component concerned are to be entered in the manufacturing documents (workshop drawings, etc.). This includes not only scantlings but - where relevant - such items as surface conditions (e.g. finishing of flame cut edges and weld seams), and special methods of manufacture involved as well as inspection and acceptance requirements and where relevant permissible tolerances. So far as for this aim a standard is used (works or national standard etc.) it is to be submitted to the Society. For weld joint details, see Ch 11, Sec 2.

If, due to missing or insufficient details in the manufacturing documents, the quality or functional ability of the component is doubtful, the Society may require appropriate improvements to be submitted by the manufacturer. This includes the provision of supplementary or additional parts (for example reinforcements) even if these were not required at the time of plan approval.

## SECTION 4 SYMBOLS AND DEFINITIONS

### 1 Primary symbols and units

#### 1.1

##### 1.1.1

Unless otherwise specified, the general symbols and their units used in the present Rules are those defined in Table 1.

<b>Table 1 Primary symbols</b>		
<i>Symbol</i>	<i>Meaning</i>	<i>Units</i>
<i>A</i>	Area	m <sup>2</sup>
	Sectional area of ordinary stiffeners and primary members	cm <sup>2</sup>
<i>B</i>	Moulded breadth of ship (see [2])	m
<i>C</i>	Coefficient	-
<i>D</i>	Depth of ship (see [2])	m
<i>E</i>	Young's modulus	N/mm <sup>2</sup>
<i>F</i>	Force and concentrated loads	kN
<i>I</i>	Hull girder inertia	m <sup>4</sup>
	Inertia of ordinary stiffeners and primary members	cm <sup>4</sup>
<i>L</i>	Length of ship (see [2])	m
<i>M</i>	Bending moment	kN.m
<i>Q</i>	Shear force	kN
<i>S</i>	Spacing of primary supporting members	
<i>T</i>	Draught of ship (see [2])	m
<i>V</i>	Ship's speed	knot
<i>Z</i>	Hull girder section modulus	m <sup>3</sup>
<i>a</i>	Acceleration	m/s <sup>2</sup>
<i>b</i>	Width of attached plating	m
	Width of face plate of ordinary stiffeners and primary members	mm
<i>g</i>	Gravity acceleration (see [2])	m/s <sup>2</sup>
<i>h</i>	Height	m
	Web height of ordinary stiffeners and primary members	mm
<i>k</i>	Material factor (see [2])	-
<i>ℓ</i>	Length / Span of ordinary stiffeners and primary supporting members	m
<i>m</i>	Mass	t
<i>n</i>	Number of items	-
<i>p</i>	Pressure	kN/m <sup>2</sup>
<i>r</i>	Radius	mm
	Radius of curvature of plating or bilge radius	m
<i>s</i>	Spacing of ordinary stiffeners	m
<i>t</i>	Thickness	mm
<i>w</i>	Section modulus of ordinary stiffeners and primary supporting members	cm <sup>3</sup>
<i>x</i>	X coordinate along longitudinal axis (see [4])	m
<i>y</i>	Y coordinate along transverse axis (see [4])	m
<i>z</i>	Z coordinate along vertical axis (see [4])	m
<i>γ</i>	Safety factor	-
<i>δ</i>	Deflection / Displacement	mm
<i>θ</i>	Angle	deg

$\xi$	Weibull shape parameter	-
$\rho$	Density	t/m <sup>3</sup>
$\sigma$	Bending stress	N/mm <sup>2</sup>
$\tau$	Shear stress	N/mm <sup>2</sup>

## 2 Symbols

### 2.1 Ship's main data

#### 2.1.1

- $L$  = Rule length, in m, defined in [3.1]  
 $L_{LL}$  = Freeboard length, in m, defined in [3.2]  
 $L_{BP}$  = Length between perpendiculars, in m, is the length of the ship measured between perpendiculars taken at the extremities of the deepest subdivision load line, i.e. of the waterline which corresponds to the greatest draught permitted by the subdivision requirements which are applicable  
 $FP_{LL}$  = Forward freeboard perpendicular. The forward freeboard perpendicular is to be taken at the forward end of the length  $L_{LL}$  and is to coincide with the foreside of the stem on the waterline on which the length  $L_{LL}$  is measured  
 $AP_{LL}$  = After freeboard perpendicular. The after freeboard perpendicular is to be taken at the aft end of the length  $L_{LL}$ .  
 $B$  = Moulded breadth, in m, defined in [3.4]  
 $D$  = Depth, in m, defined in [3.5]  
 $T$  = Moulded draught, in m, defined in [3.6]  
 $T_S$  = Scantling draught, in m, taken equal to the maximum draught (see also Ch 1, Sec 1, [1.1.6])  
 $T_B$  = Minimum ballast draught at midship, in m, in normal ballast condition as defined in Ch 4, Sec 7, [2.2.1]  
 $T_{LC}$  = Midship draught, in m, in the considered loading condition  
 $\Delta$  = Moulded displacement, in tonnes, at draught  $T$ , in sea water (density  $\rho = 1.025$  t/m<sup>3</sup>)  
 $C_B$  = Total block coefficient

$$C_B = \frac{\Delta}{1.025LBT}$$

- $V$  = Maximum ahead service speed, in knots, means the greatest speed which the ship is designed to maintain in service at her deepest seagoing draught at the maximum propeller RPM and corresponding engine MCR (Maximum Continuous Rating).  
 $x, y, z$  =  $X, Y$  and  $Z$  co-ordinates, in m, of the calculation point with respect to the reference co-ordinate system.

### 2.2 Materials

#### 2.2.1

- $E$  = Young's modulus, in N/mm<sup>2</sup>, to be taken equal to:  
 $E = 2.06 \cdot 10^5$  N/mm<sup>2</sup>, for steels in general  
 $E = 1.95 \cdot 10^5$  N/mm<sup>2</sup>, for stainless steels  
 $E = 7.0 \cdot 10^4$  N/mm<sup>2</sup>, for aluminium alloys  
 $R_{eH}$  = Minimum yield stress, in N/mm<sup>2</sup>, of the material  
 $k$  = Material factor, defined in Ch 3, Sec 1, [2.2]  
 $\nu$  = Poisson's ratio. Unless otherwise specified, a value of 0.3 is to be taken into account,  
 $R_m$  = Ultimate minimum tensile strength, in N/mm<sup>2</sup>, of the material  
 $R_Y$  = Nominal yield stress, in N/mm<sup>2</sup>, of the material, to be taken equal to  $235/k$  N/mm<sup>2</sup>, unless otherwise specified.

### 2.3 Loads

#### 2.3.1

- $g$  = Gravity acceleration, taken equal to  $9.81$  m/s<sup>2</sup>  
 $\rho$  = Sea water density, taken equal to  $1.025$  t/m<sup>3</sup>

- $\rho_L$  = Density, in  $t/m^3$ , of the liquid carried  
 $\rho_C$  = Density, in  $t/m^3$ , of the dry bulk cargo carried  
 $C$  = Wave parameter, taken equal to:  

$$C = 10.75 - \left( \frac{300 - L}{100} \right)^{1.5} \text{ for } 90 \leq L < 300$$

$$C = 10.75 \text{ for } 300 \leq L < 350 \text{ m}$$
- $h$  = Height, in m, of a tank, to be taken as the vertical distance from the bottom to the top of the tank, excluding any small hatchways  
 $z_{TOP}$  = Vertical distance, in m, of the highest point of the tank from the baseline. For ballast holds,  $z_{TOP}$  is the vertical distance, in m, of the top of the hatch coaming from the baseline  
 $\ell_H$  = Length, in m, of the compartment  
 $M_{SW}$  = Design still water bending moment, in kN.m, at the hull transverse section considered:  
 $M_{SW} = M_{SW,H}$  in hogging conditions  
 $M_{SW} = M_{SW,S}$  in sagging conditions  
 $M_{WV}$  = Vertical wave bending moment, in kN.m, at the hull transverse section considered:  
 $M_{WV} = M_{WV,H}$  in hogging conditions  
 $M_{WV} = M_{WV,S}$  in sagging conditions  
 $M_{WH}$  = Horizontal wave bending moment, in kN.m, at the hull transverse section considered,  
 $Q_{SW}$  = Design still water shear force, in kN, at the hull transverse section considered  
 $Q_{WV}$  = Vertical wave shear force, in kN, at the hull transverse section considered  
 $p_S$  = Still water pressure, in  $kN/m^2$   
 $p_W$  = Wave pressure or dynamic pressures, in  $kN/m^2$   
 $p_{SF}, p_{WF}$  = Still water and wave pressure, in  $kN/m^2$ , in flooded conditions  
 $\sigma_X$  = Hull girder normal stress, in  $N/mm^2$   
 $a_X, a_Y, a_Z$  = Accelerations, in  $m/s^2$ , along  $X, Y$  and  $Z$  directions, respectively  
 $T_R$  = Roll period, in s  
 $\theta$  = Roll single amplitude, in deg  
 $T_P$  = Pitch period, in s  
 $\Phi$  = Single pitch amplitude, in deg  
 $k_r$  = Roll radius of gyration, in m  
 $GM$  = Metacentric height, in m  
 $\lambda$  = Wave length, in m.

## 2.4 Scantlings

### 2.4.1 Hull girder scantlings

- $I_Y$  = Moment of inertia, in  $m^4$ , of the hull transverse section about its horizontal neutral axis  
 $I_Z$  = Moment of inertia, in  $m^4$ , of the hull transverse section about its vertical neutral axis  
 $Z_{AB}, Z_{AD}$  = Section moduli, in  $m^3$ , at bottom and deck, respectively  
 $N$  = Vertical distance, in m, from the base line to the horizontal neutral axis of the hull transverse section.

### 2.4.2 Local scantlings

- $s$  = Spacing, in m, of ordinary stiffeners, measured at mid-span along the chord  
 $S$  = Spacing, in m, of primary supporting members, measured at mid-span along the chord  
 $\ell$  = Span, in m, of ordinary stiffener or primary supporting member, as the case may be, measured along the chord  
 $\ell_b$  = Length, in m, of brackets  
 $t_C$  = Corrosion addition, in mm  
 $h_w$  = Web height, in mm, of ordinary stiffener or primary supporting member, as the case may be  
 $t_w$  = Net web thickness, in mm, of ordinary stiffener or primary supporting member, as the case may be  
 $b_f$  = Face plate width, in mm, of ordinary stiffener or primary supporting member, as the case may be  
 $t_f$  = Net face plate thickness, in mm, of ordinary stiffener or primary supporting member, as the case may be  
 $t_p$  = Net thickness, in mm, of the plating attached to an ordinary stiffener or a primary supporting member, as the case may be  
 $b_p$  = Width, in m, of the plating attached to the stiffener or the primary supporting member, for the yielding check

$A_s$	= Net sectional area, in $\text{cm}^2$ , of the stiffener or the primary supporting member, with attached plating of width $s$
$A_{sh}$	= Net shear sectional area, in $\text{cm}^2$ , of the stiffener or the primary supporting member
$I$	= Net moment of inertia, in $\text{cm}^4$ , of ordinary stiffener or primary supporting member, as the case may be, without attached plating, around its neutral axis parallel to the plating
$I_p$	= Net polar moment of inertia, in $\text{cm}^4$ , of ordinary stiffener or primary supporting member, as the case may be, about its connection to plating
$I_w$	= Net sectional moment of inertia, in $\text{cm}^6$ , of ordinary stiffener or primary supporting member, as the case may be, about its connection to plating
$I_S$	= Net moment of inertia, in $\text{cm}^4$ , of the stiffener or the primary supporting member, with attached shell plating of width $s$ , about its neutral axis parallel to the plating
$Z$	= Net section modulus, in $\text{cm}^3$ , of an ordinary stiffener or a primary supporting member, as the case may be, with attached plating of width $bp$ .

### 3 Definitions

#### 3.1 Rule length

##### 3.1.1

The rule length  $L$  is the distance, in m, measured on the summer load waterline, from the forward side of the stem to the after side of the rudder post, or to the centre of the rudder stock where there is no rudder post.  $L$  is to be not less than 96% and need not exceed 97% of the extreme length on the summer load waterline.

##### 3.1.2

In ships without rudder stock (e.g. ships fitted with azimuth thrusters), the rule length  $L$  is to be taken equal to 97% of the extreme length on the summer load waterline.

##### 3.1.3

In ships with unusual stem or stern arrangements, the rule length  $L$  is considered on a case by case basis.

#### 3.2 Freeboard length

##### 3.2.1

Ref. ILLC, as amended (Resolution MSC.143(77) Reg. 3(1,a))

The freeboard length  $L_{LL}$  is the distance, in m, on the waterline at 85% of the least moulded depth from the top of the keel, measured from the forward side of the stem to the centre of the rudder stock.  $L_{LL}$  is to be not less than 96% of the extreme length on the same waterline.

##### 3.2.2

Ref. ILLC, as amended (Resolution MSC.143(77) Reg. 3(1,c))

Where the stem contour is concave above the water-line at 85% of the least moulded depth, both the forward end of the extreme length and the forward side of the stem are to be taken at the vertical projection to that waterline of the aftermost point of the stem contour (above that waterline) (see Fig 1).

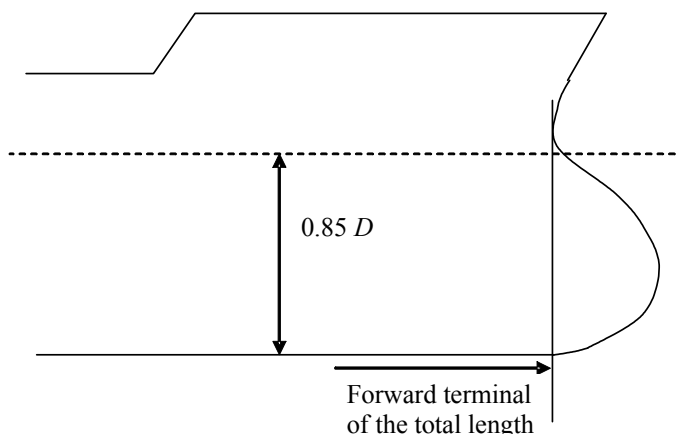

Fig. 1  
Concave stem contour

### 3.3 Ends of rule length $L$ and midship

#### 3.3.1 Fore end

The fore end (FE) of the rule length  $L$ , see Fig 2, is the perpendicular to the summer load waterline at the forward side of the stem.

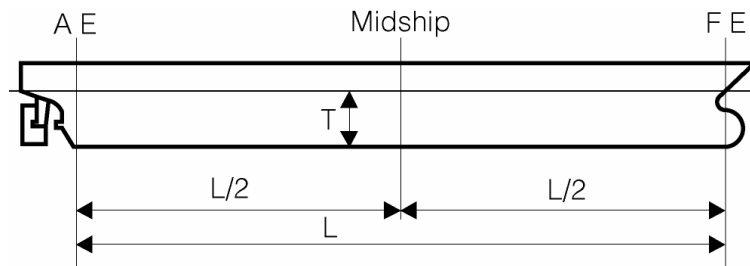

Fig. 2  
Ends and midship

The aft end (AE) of the rule length  $L$ , see Fig 2, is the perpendicular to the waterline at a distance  $L$  aft of the fore end.

#### 3.3.2 Midship

The midship is the perpendicular to the waterline at a distance  $0.5L$  aft of the fore end.

#### 3.3.3 Midship part

The midship part of a ship is the part extending  $0.4L$  amidships, unless otherwise specified.

### 3.4 Moulded breadth

#### 3.4.1

The moulded breadth  $B$  is the greatest moulded breadth, in m, measured amidships below the weather deck.

### 3.5 Depth

#### 3.5.1

The depth  $D$  is the distance, in m, measured vertically on the midship transverse section, from the moulded base line to the top of the deck beam at side on the upper-most continuous deck.

### 3.6 Moulded draught

#### 3.6.1

The moulded draught  $T$  is the distance, in m, measured vertically on the midship transverse section, from the moulded base line to the summer load line.

### 3.7 Lightweight

#### 3.7.1

The lightweight is the displacement, in t, without cargo, fuel, lubricating oil, ballast water, fresh water and feed water, consumable stores and passengers and crew and their effects.

### 3.8 Deadweight

#### 3.8.1

The deadweight is the difference, in t, between the displacement, at the summer draught in sea water of density  $\rho = 1.025 \text{ t/m}^3$ , and the lightweight.

### 3.9 Freeboard deck

#### 3.9.1

Ref. ILLC, as amended (Resolution MSC. 143(77) Reg. 3(9))

The freeboard deck is defined in Regulation 3 of the International Load Line Convention, as amended.

### **3.10 Bulkhead deck**

#### **3.10.1**

*Ref. SOLAS Reg.II-1/2 .5*

*The bulkhead deck is the uppermost deck to which the transverse watertight bulkheads, except both peak bulkheads, extend and are made effective.*

### **3.11 Strength deck**

#### **3.11.1**

The strength deck at a part of ship's length is the uppermost continuous deck at that part to which the shell plates extend.

### **3.12 Superstructure**

#### **3.12.1 General**

*Ref. ILLC. As amended (Resolution MSC.143(77) Reg. 3(10,a))*

*A superstructure is a decked structure on the free-board deck, extending from side to side of the ship or with the side plating not being inboard of the shell plating more than 0.04B.*

#### **3.12.2 Enclosed and open superstructure**

A superstructure may be:

— enclosed, where:

- 1) it is enclosed by front, side and aft bulkheads complying with the requirements of Ch 9, Sec 4
- 2) all front, side and aft openings are fitted with efficient weathertight means of closing

— open, where it is not enclosed.

### **3.13 Forecastle**

#### **3.13.1**

*Ref. ILLC, as amended (Resolution MSC.143(77) Reg. 3(10,g))*

*A forecastle is a superstructure which extends from the forward perpendicular aft to a point which is forward of the after perpendicular. The forecastle may originate from a point forward of the forward perpendicular.*

### **3.14 Raised quarterdeck**

#### **3.14.1**

*Ref. ILLC, as amended (Resolution MSC.143(77) Reg. 3(10,i))*

*A raised quarterdeck is a superstructure which extends forward from the after perpendicular, generally has a height less than a normal superstructure, and has an intact front bulkhead (sidescuttles of the non-opening type fitted with efficient deadlights and bolted man hole covers)(see Fig 3). Where the forward bulkhead is not intact due to doors and access openings, the superstructure is then to be considered as a poop.*



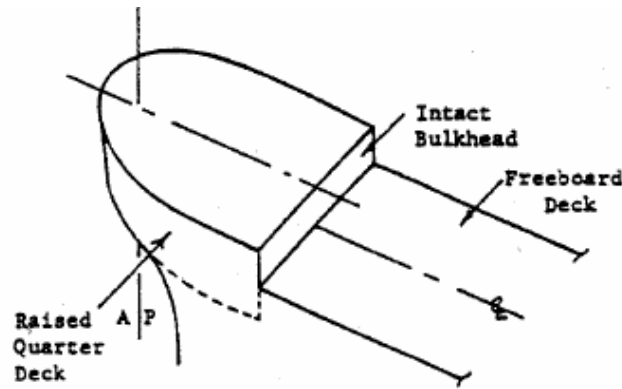

Fig. 3  
Raised quarter deck

### 3.15 Deckhouse

#### 3.15.1

A deckhouse is a decked structure other than a superstructure, located on the freeboard deck or above.

### 3.16 Trunk

#### 3.16.1

A trunk is a decked structure similar to a deckhouse, but not provided with a lower deck.

### 3.17 Wash bulkhead

#### 3.17.1

A wash bulkhead is a perforated or partial bulkhead in a tank.

### 3.18 Standard height of superstructure

#### 3.18.1

Ref. ILLC, as amended (Resolution MSC.143(77) Reg. 33)

The standard height of superstructure is defined in Table 2.

Table 2 Standard height of superstructure		
Freeboard length $L_{LL}$ in m	Standard height $h_S$ in m	
	Raised quarter deck	All other superstructures
$90 < L_{LL} < 125$	$0.3 + 0.012 L_{LL}$	$1.05 + 0.01 L_{LL}$
$L_{LL} \geq 125$	1.80	2.30

### 3.19 Type A and Type B ships

#### 3.19.1 Type A ship

Ref. ILLC, as amended (Resolution MSC.143(77) Reg. 27.1)

A Type A ship is one which:

- is designed to carry only liquid cargoes in bulk;
- has a high integrity of the exposed deck with only small access openings to cargo compartments, closed by watertight gasketed covers of steel or equivalent material
- has low permeability of loaded cargo compartments.

A Type A ship is to be assigned a freeboard following the requirements reported in the International Load Line Convention 1966, as amended.

#### 3.19.2 Type B ship

Ref. ILLC, as amended (Resolution MSC.143(77) Reg. 27.5)

*All ships which do not come within the provisions regarding Type A ships stated in [3.19.1] are to be considered as Type B ships.*

*A Type B ship is to be assigned a freeboard following the requirements reported in the International Load Line Convention 1966, as amended.*

### **3.19.3 Type B-60 ship**

*Ref. ILLC, as amended (Resolution MSC.143(77) Reg. 27.9)*

*A Type B-60 ship is any Type B ship of over 100 metres in length which, according to applicable requirements of in the International Load Line Convention 1966, as amended, is assigned with a value of tabular freeboard which can be reduced up to 60 per cent of the difference between the “B” and “A” tabular values for the appropriate ship lengths.*

### **3.19.4 Type B-100 ship**

*Ref. ILLC, as amended (Resolution MSC.143(77) Reg. 27.10)*

*A Type B-100 ship is any Type B ship of over 100 metres in length which, according to applicable requirements of in the International Load Line Convention 1966, as amended, is assigned with a value of tabular freeboard which can be reduced up to 100 per cent of the difference between the “B” and “A” tabular values for the appropriate ship lengths.*

## **3.20 Positions 1 and 2**

### **3.20.1 Position 1**

*Ref. ILLC, as amended (Resolution MSC.143(77) Reg. 13)*

*Position 1 includes:*

- exposed freeboard and raised quarter decks,
- exposed superstructure decks situated forward of  $0.25 L_{LL}$  from the perpendicular, at the forward side of the stem, to the waterline at 85% of the least moulded depth measured from the top of the keel.

### **3.20.2 Position 2**

*Ref. ILLC, as amended (Resolution MSC.143(77) Reg. 13)*

*Position 2 includes:*

- exposed superstructure decks situated aft of  $0.25 L_{LL}$  from the perpendicular, at the forward side of the stem, to the waterline at 85% of the least moulded depth measured from the top of the keel and located at least one standard height of superstructure above the freeboard deck,
- exposed superstructure decks situated forward of  $0.25 L_{LL}$  from the perpendicular, at the forward side of the stem, to the waterline at 85% of the least moulded depth measured from the top of the keel and located at least two standard heights of superstructure above the freeboard deck.

## **4 Reference co-ordinate system**

### **4.1**

#### **4.1.1**

The ship's geometry, motions, accelerations and loads are defined with respect to the following right-hand co-ordinate system (see Fig 4):

- Origin: at the intersection among the longitudinal plane of symmetry of ship, the aft end of L and the baseline
- X axis: longitudinal axis, positive forwards
- Y axis: transverse axis, positive towards portside
- Z axis: vertical axis, positive upwards.

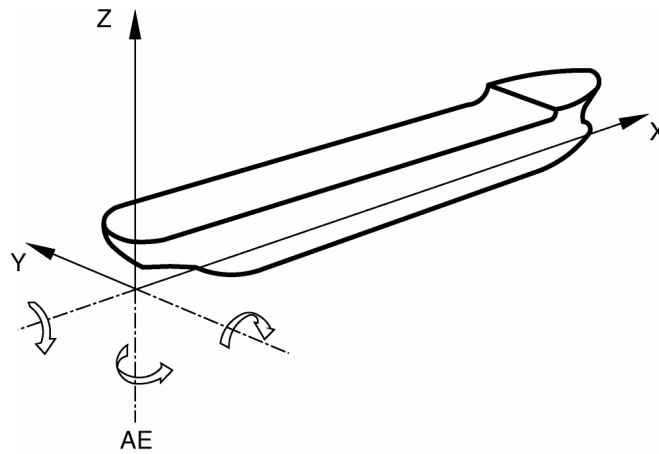

**Fig. 4**  
**Reference co-ordinate system**

#### 4.1.2

Positive rotations are oriented in anti-clockwise direction about the  $X$ ,  $Y$  and  $Z$  axes.



# **Chapter 2**

## General Arrangement Design

---

Section 1 Subdivision Arrangement

Section 2 Compartment Arrangement

Section 3 Access Arrangement



## SECTION 1 SUBDIVISION ARRANGEMENT

### 1 Number and arrangement of transverse watertight bulkheads

#### 1.1 Number of watertight bulkheads

##### 1.1.1 General

All ships, in addition to complying with the requirements of [1.1.2], are to have at least the following transverse watertight bulkheads:

- one collision bulkhead
- one after peak bulkhead
- two bulkheads forming the boundaries of the machinery space in ships with machinery amidships, and a bulkhead forward of the machinery space in ships with machinery aft. In the case of ships with an electrical propulsion plant, both the generator room and the engine room are to be enclosed by watertight bulkheads.

##### 1.1.2 Additional bulkheads

For ships not required to comply with subdivision regulations, transverse bulkheads adequately spaced, and not less in number than indicated in Table 1, are to be fitted.

Length (m)	Number of bulkheads for ships with aft machinery <sup>(1)</sup>	Numbers of bulkheads for other ships
$90 \leq L < 105$	4	5
$105 \leq L < 120$	5	6
$120 \leq L < 145$	6	7
$145 \leq L < 165$	7	8
$165 \leq L < 190$	8	9
$L \geq 190$	To be defined on a case by case basis	
(1) After peak bulkhead and aft machinery bulkhead are the same.		

### 2 Collision bulkhead

#### 2.1 Arrangement of collision bulkhead

##### 2.1.1

*Ref. SOLAS Ch. II-1, Part B, Reg. 11*

*A collision bulkhead is to be fitted which is to be watertight up to the freeboard deck. This bulkhead is to be located at a distance from the forward perpendicular  $FP_{LL}$  of not less than 5 per cent of the length  $L_{LL}$  of the ship or 10 m, whichever is the less, and not more than 8 per cent of  $L_{LL}$ .*

##### 2.1.2

*Ref. SOLAS Ch. II-1, Part B, Reg. 11*

*Where any part of the ship below the waterline extends forward of the forward perpendicular, e.g. a bulbous bow, the distances, in metres, stipulated in [2.1.1] are to be measured from a point either:*

- *at the mid-length of such extension, or*
- *at a distance 1.5 per cent of the length  $L_{LL}$  of the ship forward of the forward perpendicular, or*
- *at a distance 3 metres forward of the forward perpendicular, whichever gives the smallest measurement.*

##### 2.1.3

*Ref. SOLAS Ch. II-1, Part B, Reg. 11*

*The bulkhead may have steps or recesses provided they are within the limits prescribed in [2.1.1] or [2.1.2].*

*No door, manhole, ventilation duct or any other opening is to be fitted in this bulkhead.*

### **3 After peak, machinery space bulkheads and stern tubes**

#### **3.1**

##### **3.1.1 General**

*Ref. SOLAS Ch. II-1, Part B, Reg. 11*

*An after peak bulkhead, and bulkheads dividing the machinery space from the cargo spaces forward and aft, are also to be fitted and made watertight up to the freeboard deck. The after peak bulkhead may, however, be stepped below the bulkhead deck, provided the degree of safety of the ship as regards subdivision is not thereby diminished.*

##### **3.1.2 Sterntubes**

*Ref. SOLAS Ch. II-1, Part B, Reg. 11*

*Sterntubes are to be enclosed in a watertight space (or spaces) of moderate volume. Other measures to minimise the danger of water penetrating into the ship in case of damage to sterntube arrangements may be taken at the discretion of the Society.*

### **4 Number and arrangement of tank bulkheads**

#### **4.1 Bulkheads in compartments intended for the carriage of liquid cargoes**

##### **4.1.1**

The number and location of transverse and longitudinal watertight bulkheads in compartments intended for the carriage of liquid cargoes are to comply with the subdivision requirements to which the ship is subject.

### **5 Arrangement of transverse watertight bulkheads**

#### **5.1 General**

##### **5.1.1**

Where it is not practicable to arrange a watertight bulkhead in one plane, a stepped bulkhead may be fitted. In this case, the part of the deck which forms the step is to be watertight and equivalent in strength to the bulkhead.

### **6 Openings in watertight bulkheads**

#### **6.1 General**

##### **6.1.1**

*Ref. SOLAS Ch. II-1, Part B-1, Reg. 25-9 and IMO Res. A.684(17) - Part B*

*The number of openings in watertight subdivisions is to be kept to a minimum compatible with the design and proper working of the ship. Where penetrations of watertight bulkheads and internal decks are necessary for access, piping, ventilation, electrical cables, etc., arrangements are to be made to maintain the watertight integrity. The Society may permit relaxation in the watertightness of openings above the freeboard deck, provided that it is demonstrated that any progressive flooding can be easily controlled and that the safety of the ship is not impaired.*

##### **6.1.2**

No door, manhole ventilation duct or any other opening is permitted in the collision bulkhead below the subdivision deck.

##### **6.1.3**

Lead or other heat sensitive materials may not be used in systems which penetrate watertight subdivision bulkheads, where deterioration of such systems in the event of fire would impair the watertight integrity of the bulkheads.



#### 6.1.4

Valves not forming part of a piping system are not permitted in watertight subdivision bulkheads.

#### 6.1.5

The requirements relevant to the degree of tightness, as well as the operating systems, for doors or other closing appliances complying with the provisions in [6.2] and [6.3] are specified in Table 2.

### 6.2 Openings in the watertight bulkheads below the freeboard deck

#### 6.2.1 Openings used while at sea

*Ref. SOLAS Ch. II-1, Part B-1, Reg. 25-9*

*Doors provided to ensure the watertight integrity of internal openings which are used while at sea are to be sliding watertight doors capable of being remotely closed from the bridge and are also to be operable locally from each side of the bulkhead. Indicators are to be provided at the control position showing whether the doors are open or closed, and an audible alarm is to be provided at the door closure. The power, control and indicators are to be operable in the event of main power failure. Particular attention is to be paid to minimise the effect of control system failure. Each power-operated sliding watertight door is to be provided with an individual hand-operated mechanism. The possibility of opening and closing the door by hand at the door itself from both sides is to be assured.*

#### 6.2.2 Openings normally closed at sea

*Ref. SOLAS Ch. II-1, Part B-1, Reg. 25-9*

*Access doors and access hatch covers normally closed at sea, intended to ensure the watertight integrity of internal openings, are to be provided with means of indication locally and on the bridge showing whether these doors or hatch covers are open or closed. A notice is to be affixed to each such door or hatch cover to the effect that it is not to be left open. The use of such doors and hatch covers is to be authorised by the officer of the watch.*

#### 6.2.3 Doors or ramps in large cargo spaces

*Ref. SOLAS Ch. II-1, Part B-1, Reg. 25-9*

*Watertight doors or ramps of satisfactory construction may be fitted to internally subdivide large cargo spaces, provided that the Society is satisfied that such doors or ramps are essential. These doors or ramps may be hinged, rolling or sliding doors or ramps, but are not to be remotely controlled.*

*Such doors are to be closed before the voyage commences and are to be kept closed during navigation. Should any of the doors or ramps be accessible during the voyage, they are to be fitted with a device which prevents unauthorised opening.*

The word “satisfactory” means that scantlings and sealing requirements for such doors or ramps are to be sufficient to withstand the maximum head of the water at the flooded waterline.

#### 6.2.4 Openings permanently kept closed at sea

*Ref. SOLAS Ch. II-1, Part B-1, Reg. 25-9*

*Other closing appliances which are kept permanently closed at sea to ensure the watertight integrity of internal openings are to be provided with a notice which is to be affixed to each such closing appliance to the effect that it is to be kept closed. Manholes fitted with closely bolted covers need not be so marked.*

### 6.3 Openings in the bulkheads above the freeboard deck

#### 6.3.1 General

The openings in flooding boundaries located below the waterline at the equilibrium of the final stage of flooding are to be watertight. The openings immersed within the range of the positive righting lever curve are

only to be weathertight.

<b>Table 2 Doors</b>									
			<i>Sliding type</i>			<i>Hinged type</i>			<i>Rolling type (cargo deck between deck spaces)</i>
			<i>Remote operation indication on the bridge</i>	<i>Indicator on the bridge</i>	<i>Local operation only</i>	<i>Remote operation indication on the bridge</i>	<i>Indicator on the bridge</i>	<i>Local operation only</i>	
Watertight	Below the freeboard deck	Open at sea	X						
		Normally closed (2)		X			X (3)		
		Remain closed (2)			X (4) (5)			X (4) (5)	X (4) (5)
Weathertight / watertight (1)	Above the freeboard deck	Open at sea	X						
		Normally closed (2)		X			X		
		Remain closed (2)						X (4) (5)	

(1) Watertight doors are required when they are located below the waterline at the equilibrium of the final stage of flooding; otherwise a weathertight door is accepted.  
(2) Notice to be affixed on both sides of the door: “to be kept closed at sea”.  
(3) Type A ships of 150 m and upwards, and Type B ships with a reduced freeboard may have a hinged watertight door between the engine room and the steering gear space, provided that the sill of this door is above the summer load waterline.  
(4) The door is to be closed before the voyage commences.  
(5) If the door is accessible during the voyage, a device which prevents unauthorised opening is to be fitted.

### 6.3.2 Doors used while at sea

Ref. SOLAS Ch. II-1, Part B-1, Reg. 25-9x

*The doors used while at sea are to be sliding doors capable of being remotely closed from the bridge and are also to be operable locally from each side of the bulkhead. Indicators are to be provided at the control position showing whether the doors are open or closed, and an audible alarm is to be provided at the door closure. The power, control and indicators are to be operable in the event of main power failure. Particular attention is to be paid to minimise the effect of control system failure. Each power-operated sliding watertight door is to be provided with an individual hand-operated mechanism. It should be possible to open and close the door by hand at the door itself from both sides.*

### 6.3.3 Doors normally closed at sea

Ref. SOLAS Ch. II-1, Part B-1, Reg. 25-9

*The doors normally closed at sea are to be provided with means of indication locally and on the bridge showing whether these doors are open or closed. A notice is to be affixed to each door to the effect that it is not to be left open.*

### 6.3.4 Openings kept permanently closed at sea

Ref. SOLAS Ch. II-1, Part B-1, Reg. 25-9

*The doors kept closed at sea are to be hinged doors. Such doors and the other closing appliances which are kept closed at sea are to be provided with a notice affixed to each closing appliance to the effect that it is to be kept closed. Manholes fitted with closely bolted covers need not be so marked.*

## SECTION 2 COMPARTMENT ARRANGEMENT

### 1 Definitions

#### 1.1 Cofferdam

##### 1.1.1

A cofferdam means an empty space arranged so that compartments on each side have no common boundary; a cofferdam may be located vertically or horizontally. As a rule, a cofferdam is to be properly ventilated and of sufficient size to allow proper inspection, maintenance and safe evacuation.

#### 1.2 Machinery spaces of category A

##### 1.2.1

*Ref. SOLAS Ch. II-2, Part A, Reg. 3.31*

*Machinery spaces of category A are those spaces or trunks to such spaces which contain:*

- *internal combustion machinery used for main propulsion; or*
- *internal combustion machinery used for purposes other than propulsion where such machinery has in the aggregate a total power output of not less than 375 kW; or*
- *any oil fired boiler or fuel oil unit.*

### 2 Cofferdams

#### 2.1 Cofferdam arrangement

##### 2.1.1

Cofferdams are to be provided between compartments intended for liquid hydrocarbons (fuel oil, lubricating oil) and those intended for fresh water (drinking water, water for propelling machinery and boilers) as well as tanks intended for the carriage of liquid foam for fire extinguishing.

##### 2.1.2

Cofferdams separating fuel oil tanks from lubricating oil tanks and the latter from those intended for the carriage of liquid foam for fire extinguishing or fresh water or boiler feed water may be waived when deemed impracticable or unreasonable by the Society in relation to the characteristics and dimensions of the spaces containing such tanks, provided that:

- the thickness of common boundary plates of adjacent tanks is increased, with respect to the thickness obtained according to Ch 6, Sec 1, by 2 mm in the case of tanks carrying fresh water or boiler feed water, and by 1 mm in all other cases
- the sum of the throats of the weld fillets at the edges of these plates is not less than the thickness of the plates themselves
- the structural test is carried out with a head increased by 1 m with respect to Ch 11, Sec 3.

##### 2.1.3

Spaces intended for the carriage of flammable liquids are to be separated from accommodation and service spaces by means of a cofferdam.

##### 2.1.4

Cofferdams are only required between fuel oil double bottoms and tanks immediately above where the inner bottom plating is subjected to the head of fuel oil contained therein, as in the case of a double bottom with its top raised at the sides.

Where a corner to corner situation occurs, tanks are not to be considered to be adjacent.

Adjacent tanks not separated by cofferdams are to have adequate dimensions to ensure easy inspection.

### 3 Double bottoms

#### 3.1 General

##### 3.1.1

*Ref. SOLAS Ch. II-1, Part B, Reg. 12-1*

*A double bottom is to be fitted extending from the collision bulkhead to the after peak bulkhead, as far as this is practicable and compatible with the design and proper working of the ship.*

##### 3.1.2

*Ref. SOLAS Ch. II-1, Part B, Reg. 12-1*

*Where a double bottom is required to be fitted, its depth is to satisfy the provisions of Ch 3, Sec 6, [6] and the inner bottom is to be continued out to the ship side in such a manner as to protect the bottom to the turn of the bilge.*

##### 3.1.3

*Ref. SOLAS Ch. II-1, Part B, Reg. 12-1*

*Small wells constructed in the double bottom, in connection with the drainage arrangements of holds, are not to extend in depth more than necessary. A well extending to the outer bottom, may, however, be permitted at the after end of the shaft tunnel of the ship. Other wells may be permitted by the Society if it is satisfied that the arrangements give protection equivalent to that afforded by a double bottom complying with [3.1].*

##### 3.1.4

*Ref. SOLAS Ch. II-1, Part B, Reg. 12-1*

*A double bottom need not be fitted in way of water-tight compartments used exclusively for the carriage of liquids, provided the safety of the ship in the event of bottom damage is not, in the opinion of the Society, thereby impaired.*

### 4 Compartment forward of the collision bulkhead

#### 4.1 General

##### 4.1.1

The fore peak and other compartments located forward of the collision bulkhead may not be arranged for the carriage of fuel oil or other flammable products.

### 5 Minimum bow height

#### 5.1 General

##### 5.1.1

*Ref. ILLC, as amended (Resolution MSC.143(77) Reg. 39(1))*

*The bow height  $F_b$ , defined as the vertical distance at the forward perpendicular between the waterline corresponding to the assigned summer freeboard and the designed trim and the top of the exposed deck at side, is to be not less than:*

$$F_b = (6075(L_{LL}/100) - 1875(L_{LL}/100)^2 + 200(L_{LL}/100)^3)(2.08 + 0.609C_B - 1.603C_{wf} - 0.0129(L/T_1))$$

where:

$F_b$  = Calculated minimum bow height, in mm

$T_1$  = Draught at 85% of the depth for freeboard  $D_1$ , in m

$D_1$  = Depth for freeboard, is the moulded depth amidship plus the freeboard deck thickness at side. The depth for freeboard in a ship having a rounded gunwale with a radius greater than 4% of the breadth ( $B$ ) or having topsides of unusual form is the depth for freeboard of a ship having a midship section with vertical topsides and with the same round of beam and area of topside section equal to that

$C_{wf}$  = provided by the actual midship section.  
Waterplane area coefficient forward of  $L_{LL}/2$ :

$$C_{wf} = \frac{A_{wf}}{\frac{L_{LL}}{2} B}$$

$A_{wf}$  = Waterplane area forward of  $L_{LL}/2$  at draught  $T_1$ , in  $m^2$ .

For ships to which timber freeboards are assigned, the summer freeboard (and not the timber summer freeboard) is to be assumed when applying the formula above.

### 5.1.2

Ref. ILLC, as amended (Resolution MSC.143(77) Reg. 39.(2))

Where the bow height required in paragraph [5.1.1] is obtained by sheer, the sheer is to extend for at least 15% of the length of the ship measured from the forward perpendicular. Where it is obtained by fitting a superstructure, such superstructure is to extend from the stem to a point at least 0.07L abaft the forward perpendicular, and is to be enclosed as defined Ch 9, Sec 4.

### 5.1.3

Ref. ILLC, as amended (Resolution MSC.143(77) Reg. 39(3))

Ships which, to suit exceptional operational requirements, cannot meet the requirements in [5.1.1] and [5.1.2] will be considered by the Society on a case by case basis.

### 5.1.4

Ref. ILLC, as amended (Resolution MSC.143(77) Reg. 39(4, a))

The sheer of the forecastle deck may be taken into account, even if the length of the forecastle is less than 0.15L, but greater than 0.07L, provided that the forecastle height is not less than one half of standard height of superstructure between 0.07L and the forward perpendicular.

### 5.1.5

Ref. ILLC, as amended (Resolution MSC.143(77) Reg. 39(4, b))

Where the forecastle height is less than one half of the standard height of superstructure, the credited bow height may be determined as follows:

- a) Where the freeboard deck has sheer extending from abaft 0.15L, by a parabolic curve having its origin at 0.15L abaft the forward perpendicular at a height equal to the midship depth of the ship, extended through the point of intersection of forecastle bulkhead and deck, and up to a point at the forward perpendicular not higher than the level of the forecastle deck (as illustrated in Fig 1). However, if the value of the height denoted  $h_t$  in Fig 1 is smaller than the value of the height denoted  $h_b$  then  $h_t$  may be replaced by  $h_b$  in the available bow height, where:

$$h_t = Z_b \left( \frac{0.15L}{x_b} \right)^2 - Z_t$$

$Z_b$  = As defined in Fig 1

$Z_t$  = As defined in Fig 1

$h_f$  = Half standard height of superstructure

- b) Where the freeboard deck has sheer extending for less than 0.15L or has no sheer, by a line from the forecastle deck at side at 0.07L extended parallel to the base line to the forward perpendicular (as illustrated in Fig 2).

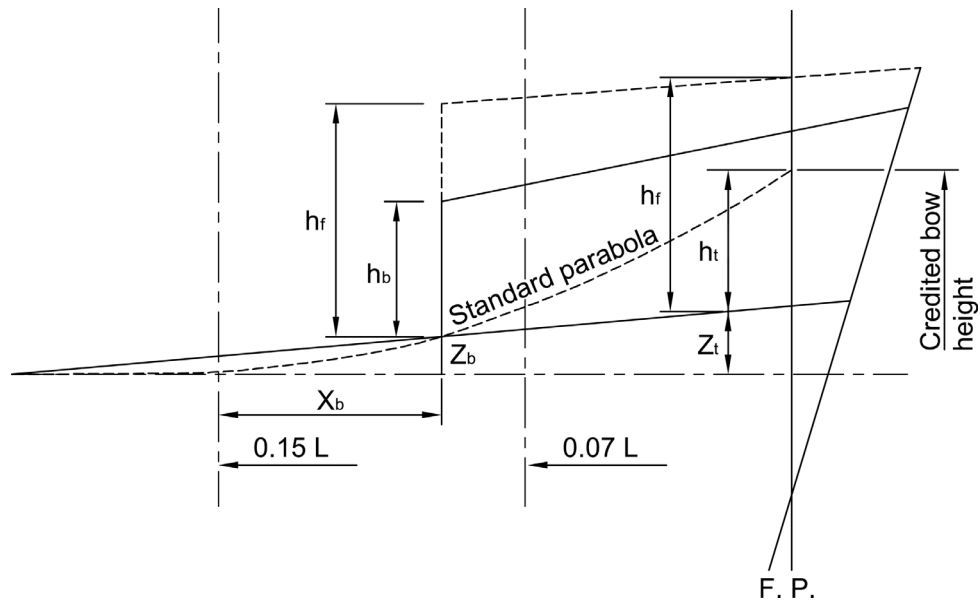

**Fig. 1**  
 Credited bow height where the freeboard deck has shear extending from abaft  $0.15L$

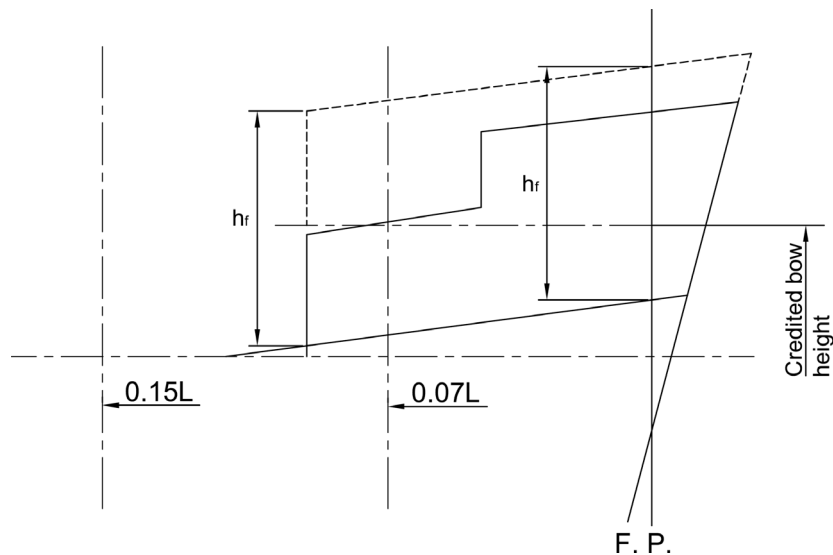

**Fig. 2**  
 Credited bow height where the freeboard deck has shear extending for less than  $0.15L$

## 6 Shaft tunnels

### 6.1 General

#### 6.1.1

Shaft tunnels are to be watertight.

## 7 Watertight ventilators and trunks

### 7.1 General

#### 7.1.1

*Ref. SOLAS Ch. II-1, Part B, Reg. 19.1*

*Watertight ventilators and trunks are to be carried at least up to the freeboard deck.*

## **8 Fuel oil tanks**

### **8.1 General**

#### **8.1.1**

*Ref. SOLAS Ch. II-2, Part B, Reg. 4.2*

*The arrangements for the storage, distribution and utilisation of the fuel oil are to be such as to ensure the safety of the ship and persons on board.*

#### **8.1.2**

*Ref. SOLAS Ch. II-2, Part B, Reg. 4.2*

*As far as practicable, fuel oil tanks are to be part of the ship's structure and are to be located outside machinery spaces of category A.*

*Where fuel oil tanks, other than double bottom tanks, are necessarily located adjacent to or within machinery spaces of category A, at least one of their vertical sides is to be contiguous to the machinery space boundaries, they are preferably to have a common boundary with the double bottom tanks and the area of the tank boundary common with the machinery spaces is to be kept to a minimum.*

*Where such tanks are situated within the boundaries of machinery spaces of category A, they may not contain fuel oil having a flashpoint of less than 60°C.*

#### **8.1.3**

*Ref. SOLAS Ch. II-2, Part B, Reg. 4.2*

*Fuel oil tanks may not be located where spillage or leakage therefrom can constitute a hazard by falling on heated surfaces.*

*Precautions are to be taken to prevent any oil that may escape under pressure from any pump, filter or heater from coming into contact with heated surfaces.*

*Fuel oil tanks in boiler spaces may not be located immediately above the boilers or in areas subjected to high temperatures, unless special arrangements are provided in agreement with the Society.*

#### **8.1.4**

*Where a compartment intended for goods or coal is situated in proximity of a heated liquid container, suitable thermal insulation is to be provided.*

## SECTION 3 ACCESS ARRANGEMENT

### 1 General

#### 1.0 Application

##### 1.0.1

This section applies to ships of 20 000 gross tonnage and over.

#### 1.1 Means of access to cargo and other spaces

##### 1.1.1

*Ref. SOLAS Reg.II-1/3-6 .2.1 (Resolution MSC.151(78))*

*Each space is to be provided with means of access to enable, throughout the life of a ship, overall and close-up inspections and thickness measurements of the ship's structures. Such means of access are to comply with [1.3] and [2].*

##### 1.1.2

*Ref. SOLAS Reg.II-1/3-6 .2.2 (Resolution MSC.151(78))*

*Where a permanent means of access may be susceptible to damage during normal cargo loading and unloading operations or where it is impracticable to fit permanent means of access, the Administration may allow, in lieu thereof, the provision of movable or portable means of access, as specified in [2], provided that the means of attaching, rigging, suspending or supporting the portable means of access forms a permanent part of the ship's structure. All portable equipment are to be capable of being readily erected or deployed by ship's personnel.*

##### 1.1.3

*Ref. SOLAS Reg.II-1/3-6 .2.3 (Resolution MSC.151(78))*

*The construction and materials of all means of access and their attachment to the ship's structure are to be to the satisfaction of the Society.*

#### 1.2 Safe access to cargo holds, ballast tanks and other spaces

##### 1.2.1

*Ref. SOLAS Reg.II-1/3-6 .3.1 (Resolution MSC.151(78)) and IACS UI SC191*

*Safe access to cargo holds, cofferdams, ballast tanks and other spaces in the cargo area are to be direct from the open deck and such as to ensure their complete inspection. Safe access to double bottom spaces or to forward ballast tanks may be from a pump-room, deep cofferdam, pipe tunnel, cargo hold, double hull space or similar compartment not intended for the carriage of oil or hazardous cargoes.*

*Access to a double side skin space may be either from a topside tank or double bottom tank or from both.*

##### 1.2.2

*Ref. SOLAS Reg.II-1/3-6 .3.2 (Resolution MSC.151(78))*

*Tanks, and subdivisions of tanks, having a length of 35 m or more, are to be fitted with at least two access hatchways and ladders, as far apart as practicable.*

*Tanks less than 35 m in length are to be served by at least one access hatchway and ladder.*

*When a tank is subdivided by one or more swash bulkheads or similar obstructions which do not allow ready means of access to the other parts of the tank, at least two hatchways and ladders are to be fitted.*

##### 1.2.3

*Ref. SOLAS Reg.II-1/3-6 .3.3 (Resolution MSC.151(78))*

*Each cargo hold is to be provided with at least two means of access as far apart as practicable. In general, these accesses are to be arranged diagonally, for example one access near the forward bulkhead on the port side, the other one near the aft bulkhead on the starboard side.*



## 1.3 General technical specifications

### 1.3.1

Ref. SOLAS Reg.II-1/3-6 .5.1 (Resolution MSC.151(78)) and IACS UI SC191

For access through horizontal openings, hatches or manholes, the dimensions are to be sufficient to allow a person wearing a self-contained air-breathing apparatus and protective equipment to ascend or descend any ladder without obstruction and also provide a clear opening to facilitate the hoisting of an injured person from the bottom of the space. The minimum clear opening is to be not less than 600 mm × 600 mm, with corner radii up to 100 mm maximum.

In such a case where as a consequence of structural analysis the stress is to be reduced around the opening, it is considered appropriate to take measures to increase the clear opening, e.g. 600 × 800 with 300 mm radii, in which a clear opening of 600 × 600 mm with corner radii up to 100 mm maximum fits.

When access to a cargo hold is arranged through the cargo hatch, the top of the ladder is to be placed as close as possible to the hatch coaming. Access hatch coamings having a height greater than 900 mm are also to have steps on the outside in conjunction with the ladder.

### 1.3.2

Ref. SOLAS Reg.II-1/3-6 .5.2 (Resolution MSC.151(78)) and IACS UI SC191

For access through vertical openings, or manholes, in swash bulkheads, floors, girders and web frames providing passage through the length and breadth of the space, the minimum opening is to be not less than 600 mm × 800 mm with corner radii of 300 mm at a height of not more than 600 mm from the bottom shell plating unless gratings or other foot holds are provided.

Subject to verification of easy evacuation of injured person on a stretcher the vertical opening 850 mm × 620 mm with wider upper half than 600 mm, while the lower half may be less than 600 mm with the overall height not less than 850 mm is considered acceptable alternative to the opening of 600 mm × 800 mm with corner radii of 300 mm (see Fig 1).

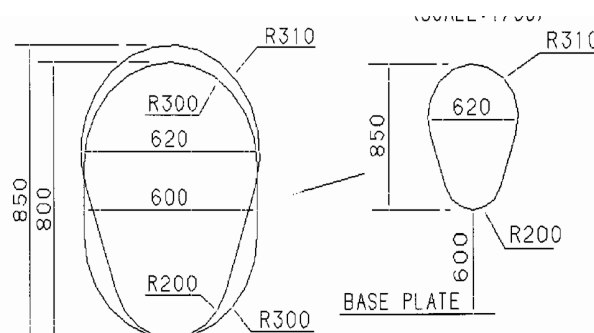

Fig. 1  
Alternative vertical opening

## 2 Technical provisions for means of access

### 2.1 Definitions

Ref. IMO Technical Provisions, 2 (Resolution MSC.158(78))

#### 2.1.1 Rung

Rung means the step of vertical ladder or step on the vertical surface.

#### 2.1.2 Tread

Tread means the step of inclined ladder, or step for the vertical access opening.

#### 2.1.3 Flight of a ladder

Flight of an inclined ladder means the actual stringer length of an inclined ladder.

For vertical ladders, it is the distance between the platforms.

### **2.1.4 Stringer**

*Stringer means:*

- 1) *the frame of a ladder; or*
- 2) *the stiffened horizontal plating structure fitted on side shell, transverse bulkheads and/or longitudinal bulkheads in the space. For the purpose of ballast tanks of less than 5 m width forming double side spaces, the horizontal plating structure is credited as a stringer and a longitudinal permanent means of access, if it provides a continuous passage of 600 mm or more in width past frames or stiffeners on the side shell or longitudinal bulkhead. Openings in stringer plating utilized as permanent means of access are to be arranged with guard rails or grid covers to provide safe passage on the stringer or safe access to each transverse web.*

### **2.1.5 Vertical ladder**

*Vertical ladder means a ladder of which the inclined angle is 70° and over up to 90°. Vertical ladder is to be not skewed by more than 2°.*

### **2.1.6 Overhead obstructions**

*Overhead obstructions mean the deck or stringer structure including stiffeners above the means of access.*

### **2.1.7 Distance below deck head**

*Distance below deck head means the distance below the plating.*

### **2.1.8 Cross deck**

*Cross deck means the transverse area of main deck which is located inboard and between hatch coamings.*

## **2.2 Permanent means of access**

### **2.2.1**

*Ref. IMO Technical Provisions, 3.1 & 3.2 (Resolution MSC.158(78))*

*Structural members, except those in double bottom spaces, are to be provided with a permanent means of access to the extent as specified in [2.7] to [2.13].*

*Permanent means of access are, as far as possible, to be integral to the structure of the ships, thus ensuring that they are robust and at the same time contributing to the overall strength of the structure, of the ship.*

### **2.2.2**

*Ref. IMO Technical Provisions, 3.3 (Resolution MSC.158(78)) and IACS UI SC191*

*Elevated passageways forming sections of a permanent means of access, where fitted, are to have a minimum clear width of 600 mm, except for going around vertical webs where the minimum clear width may be reduced to 450 mm, and to have guard rails over the open side of their entire length. For stand alone passageways guard rails are to be fitted on both sides of these structures.*

*Sloping structure providing part of the access and that are sloped by 5 or more degrees from horizontal plane when a ship is in upright position at even-keel, is to be of a non-skid construction.*

*Guard rails are to be 1000 mm in height and consist of a rail and intermediate bar 500 mm in height and of substantial construction. Stanchions are to be not more than 3 m apart.*

### **2.2.3**

*Ref. IMO Technical Provisions, 3.4 (Resolution MSC.158(78))*

*Access to permanent means of access and vertical openings from the ship's bottom are to be provided by means of easily accessible passageways, ladders or treads. Treads are to be provided with lateral support for the foot. Where the rungs of ladders are fitted against a vertical surface, the distance from the centre of the rungs to the surface is to be at least 150 mm. Where vertical manholes are fitted higher than 600 mm above the walking level, access is to be facilitated by means of treads and hand grips with platform landings on both sides.*

## **2.3 Construction of ladders**

### **2.3.1 General**

*Ref. IMO Technical Provisions, 3.5 (Resolution MSC.158(78))*

*Permanent inclined ladders are to be inclined at an angle of less than 70°. There are to have no obstructions*

within 750 mm of the face of the inclined ladder, except that in way of an opening this clearance may be reduced to 600 mm. Resting platforms of adequate dimensions are normally to be provided at a maximum of 6 m vertical height. Ladders and handrails are to be constructed of steel or equivalent material of adequate strength and stiffness and securely attached to the tank structure by stays. The method of support and length of stay is to be such that vibration is reduced to a practical minimum. In cargo holds, ladders are to be designed and arranged so that cargo handling difficulties are not increased and the risk of damage from cargo handling gear is minimized.

### **2.3.2 Inclined ladders**

*Ref. IMO Technical Provisions, 3.6 (Resolution MSC.158(78))*

The width of inclined ladders between stringers is to be not less than 400 mm. The treads are to be equally spaced at a distance apart, measured vertically, of between 200 mm and 300 mm. When steel is used, the treads are to be formed of two square bars of not less than 22 mm by 22 mm in section, fitted to form a horizontal step with the edges pointing upward. The treads are to be carried through the side stringers and attached thereto by double continuous welding. All inclined ladders are to be provided with handrails of substantial construction on both sides, fitted at a convenient distance above the treads.

### **2.3.3 Vertical or spiral ladders**

*Ref. IMO Technical Provisions, 3.7 (Resolution MSC.158(78))*

For vertical ladders or spiral ladders, the width and construction are to be in accordance with international or national standards.

## **2.4 Access through openings**

### **2.4.1 Access through horizontal openings, hatches or manholes**

*Ref. IMO Technical Provisions, 3.10 (Resolution MSC.158(78))*

For access through horizontal openings, hatches or manholes, the minimum clear opening is to be not less than 600 mm × 600 mm. When access to a cargo hold is arranged through the cargo hatch, the top of the ladder is to be placed as close as possible to the hatch coaming.

Access hatch coamings having a height greater than 900 mm are also to have steps on the outside in conjunction with the ladder.

### **2.4.2 Access through vertical openings, or manholes**

*Ref. IMO Technical Provisions, 3.11 (Resolution MSC.158(78))*

For access through vertical openings, or manholes, in swash bulkheads, floors, girders and web frames providing passage through the length and breadth of the space, the minimum opening is to be not less than 600 mm × 800 mm at a height of not more than 600 mm from the passage unless gratings or other foot holds are provided.

## **2.5 Access ladders to cargo holds and other spaces**

### **2.5.1 General**

*Ref. IMO Technical Provisions, 3.13.1 & 3.13.2 (Resolution MSC.158(78))*

Access ladders to cargo holds and other spaces are to be:

- a) where the vertical distance between the upper surface of adjacent decks or between deck and the bottom of the cargo space is not more than 6 m, either a vertical ladder or an inclined ladder.
- b) where the vertical distance between the upper surface of adjacent decks or between deck and the bottom of the cargo space is more than 6 m, an inclined ladder or series of inclined ladders at one end of the cargo hold, except the uppermost 2.5 m of a cargo space measured clear of overhead obstructions and the lowest 6 m may have vertical ladders, provided that the vertical extent of the inclined ladder or ladders connecting the vertical ladders is not less than 2.5 m.

### **2.5.2**

*Ref. IMO Technical Provisions, 3.13.2 (Resolution MSC.158(78))*

The second means of access at the other end of the cargo hold may be formed of a series of staggered vertical ladders, which have to comprise one or more ladder linking platforms spaced not more than 6 m apart vertically and displaced to one side of the ladder. Adjacent sections of ladder are to be laterally offset from

each other by at least the width of the ladder. The uppermost, entrance section, of the ladder directly exposed to a cargo hold is to be vertical for a distance of 2.5 m measured clear of overhead obstructions and connected to a ladder-linking platform.

### **2.5.3**

*Ref. IMO Technical Provisions, 3.13.3 (Resolution MSC.158(78))*

*A vertical ladder may be used as a means of access to topside tanks, where the vertical distance is 6 m or less between the deck and the longitudinal means of access in the tank or the stringer or the bottom of the space immediately below the entrance. The uppermost, entrance section from deck, of the vertical ladder of the tank is to be vertical for a distance of 2.5 m measured clear of the overhead obstructions and comprises a ladder linking platform unless landing on the longitudinal means of access, the stringer or the bottom within the vertical distance, it should be displaced to one side of a vertical ladder.*

### **2.5.4**

*Ref. IMO Technical Provisions, 3.13.4 (Resolution MSC.158(78))*

*Unless allowed in [2.5.3], an inclined ladder or combination of ladders are to be used for access to a tank or a space where the vertical distance is greater than 6 m between the deck and a stringer immediately below the entrance, between stringers, or between the deck or a stringer and the bottom of the space immediately below the entrance.*

### **2.5.5**

*Ref. IMO Technical Provisions, 3.13.5 (Resolution MSC.158(78))*

*In case of [2.5.4], the uppermost, entrance section from deck, of the ladder is to be vertical for a distance of 2.5 m clear of the overhead obstructions and connected to a landing platform and continued with an inclined ladder. The flights of inclined ladders are to be not more than 9 m in actual length and the vertical height is normally to be not more than 6 m. The lowermost section of the ladders may be vertical for a vertical distance of not less than 2.5 m.*

### **2.5.6**

*Ref. IMO Technical Provisions, 3.13.6 (Resolution MSC.158(78))*

*In double side skin spaces of less than 2.5 m width, the access to the space may be by means of vertical ladders that comprises one or more ladder linking platforms spaced not more than 6 m apart vertically and displace to one side of the ladder.*

*Adjacent sections of ladder are to be laterally offset from each other by at least the width of the ladder.*

### **2.5.7**

*Ref. IMO Technical Provisions, 3.13.7 (Resolution MSC.158(78))*

*A spiral ladder is considered acceptable as an alternative for inclined ladders. In this regard, the uppermost 2.5 m can continue to be comprised of the spiral ladder and need not change over to vertical ladders.*

## **2.6 Access ladders to tanks**

### **2.6.1**

*Ref. IMO Technical Provisions, 3.14 (Resolution MSC.158(78))*

*The uppermost, entrance section from deck, of the vertical ladder providing access to a tank should be vertical for a distance of 2.5 m measured clear of the overhead obstructions and comprises a ladder linking platform. It should be displaced to one side of a vertical ladder. The vertical ladder can be between 1.6 m and 3 m below deck structure if it lands on a longitudinal or athwartship permanent means of access fitted within that range.*

## **2.7 Access to underdeck structure of cargo holds**

### **2.7.1**

*Ref. IMO Technical Provisions, Tab 2, 1.1 (Resolution MSC.158(78))*

*Permanent means of access are to be fitted to provide access to the overhead structure at both sides of the cross deck and in the vicinity of the centerline.*

*Each means of access is to be accessible from the cargo hold access or directly from the main deck and installed at a minimum of 1.6 m to a maximum of 3 m below the deck.*

### **2.7.2**

Ref. IMO Technical Provisions, Tab 2, 1.2 (Resolution MSC.158(78))

*An athwartship permanent means of access fitted on the transverse bulkhead at a minimum 1.6 m to a maximum 3 m below the cross-deck head is accepted as equivalent to [2.7.1].*

### **2.7.3**

Ref. IMO Technical Provisions, Tab 2, 1.3 (Resolution MSC.158(78))

*Access to the permanent means of access to overhead structure of the cross deck may also be via the upper stool.*

### **2.7.4**

Ref. IMO Technical Provisions, Tab 2, 1.4  
(Resolution MSC.158(78)) and IACS UI SC191

*Ships having transverse bulkheads with full upper stools, i.e. stools with a full extension between top side tanks and between hatch end beams, with access from the main deck which allows monitoring of all framing and plates from inside, do not require permanent means of access of the cross deck.*

### **2.7.5**

Ref. IMO Technical Provisions, Tab 2, 1.5 (Resolution MSC.158(78))

*Alternatively, movable means of access may be utilized for access to the overhead structure of cross deck if its vertical distance is 17 m or less above the tank top.*

## **2.8 Access to double side skin tanks in double side bulk carriers**

### **2.8.1**

Ref. IMO Technical Provisions, Tab 2, 2.8 & Tab 1, 2.1  
(Resolution MSC.158(78))

*For double side spaces above the upper knuckle point of the bilge hopper sections, permanent means of access are to be provided in accordance with the following requirements:*

- a) *where the vertical distance between horizontal uppermost stringer and deck head is 6 m or more, one continuous longitudinal permanent means of access is to be provided for the full length of the tank with a means to allow passing through transverse webs installed at a minimum of 1.6 m to a maximum of 3 m below the deck head with a vertical access ladder at each end of the tank;*
- b) *continuous longitudinal permanent means of access, which are integrated in the structure, at a vertical distance not exceeding 6 m apart; and*
- c) *plated stringers are to be, as far as possible, in alignment with horizontal girders of transverse bulkheads.*

## **2.9 Access to vertical structures of cargo holds in single side bulk carriers**

### **2.9.1**

Ref. IMO Technical Provisions, Tab 2, 1.6  
(Resolution MSC.158(78))

*Permanent means of vertical access are to be provided in all cargo holds and built into the structure to allow for an inspection of a minimum of 25 % of the total number of hold frames port and starboard equally distributed throughout the hold including at each end in way of transverse bulkheads. But in no circumstance is this arrangement to be less than 3 permanent means of vertical access fitted to each side (fore and aft ends of hold and mid-span).*

*Permanent means of vertical access fitted between two adjacent hold frames is counted for an access for the inspection of both hold frames. A means of portable access may be used to gain access over the sloping plating of lower hopper ballast tanks.*

### **2.9.2**

Ref. IMO Technical Provisions, Tab 2, 1.7  
(Resolution MSC.158(78))

*In addition, portable or movable means of access are to be utilized for access to the remaining hold frames up to their upper brackets and transverse bulkheads.*

### **2.9.3**

*Ref. IMO Technical Provisions, Tab 2, 1.8  
(Resolution MSC.158(78))*

*Portable or movable means of access may be utilized for access to hold frames up to their upper bracket in place of the permanent means required in [2.9.1]. These means of access are to be carried on board the ship and readily available for use.*

### **2.9.4**

*Ref. IMO Technical Provisions, Tab 2, 1.9  
(Resolution MSC.158(78))*

*The width of vertical ladders for access to hold frames is to be at least 300 mm, measured between stringers.*

### **2.9.5**

*Ref. IMO Technical Provisions, Tab 2, 1.10  
(Resolution MSC.158(78))*

*A single vertical ladder over 6 m in length is acceptable for the inspection of the hold side frames in a single skin construction.*

## **2.10 Access to vertical structures of cargo holds in double side bulk carriers**

### **2.10.1**

*Ref. IMO Technical Provisions, Tab 2, 1.11  
(Resolution MSC.158(78))*

*For double side skin construction no vertical ladders for the inspection of the cargo hold surfaces are required. Inspection of this structure should be provided from within the double hull space.*

## **2.11 Access to top side ballast tanks in single side bulk carriers**

### **2.11.1**

*Ref. IMO Technical Provisions, Tab 2, 2.1 (Resolution MSC.158(78))*

*For each topside tank of which the height is 6 m and over, one longitudinal continuous permanent means of access is to be provided along the side shell webs and installed at a minimum of 1.6 m to a maximum of 3 m below deck with a vertical access ladder in the vicinity of each access to that tank.*

### **2.11.2**

*Ref. IMO Technical Provisions, Tab 2, 2.2 (Resolution MSC.158(78))*

*If no access holes are provided through the transverse webs within 600 mm of the tank base and the web frame rings have a web height greater than 1 m in way of side shell and sloping plating, then step rungs/grab rails are to be provided to allow safe access over each transverse web frame ring.*

### **2.11.3**

*Ref. IMO Technical Provisions, Tab 2, 2.3 (Resolution MSC.158(78))*

*Three permanent means of access, fitted at the end bay and middle bay of each tank, are to be provided spanning from tank base up to the intersection of the sloping plate with the hatch side girder. The existing longitudinal structure, if fitted on the sloping plate in the space may be used as part of this means of access.*

### **2.11.4**

*Ref. IMO Technical Provisions, Tab 2, 2.4 (Resolution MSC.158(78))*

*For topside tanks of which the height is less than 6 m, alternative or a portable means may be utilized in lieu of the permanent means of access.*

## **2.12 Access to bilge hopper ballast tanks**

### **2.12.1**

*Ref. IMO Technical Provisions, Tab 2, 2.5  
(Resolution MSC.158(78)) and IACS UI SC191*

*For each bilge hopper tank of which the height is 6 m and over, one longitudinal continuous permanent means*

*of access is to be provided along the side shell webs and installed at a minimum of 1.2 m below the top of the clear opening of the web ring with a vertical access ladder in the vicinity of each access to the tank.*

*An access ladder between the longitudinal continuous permanent means of access and the bottom of the space is to be provided at each end of the tank.*

*Alternatively, the longitudinal continuous permanent means of access can be located through the upper web plating above the clear opening of the web ring, at a minimum of 1.6 m below the deck head, when this arrangement facilitates more suitable inspection of identified structurally critical areas. An enlarged longitudinal frame, of at least 600 mm clear width can be used for the purpose of the walkway.*

*For double side skin bulk carriers the longitudinal continuous permanent means of access may be installed within 6 m from the knuckle point of the bilge, if used in combination with alternative methods to gain access to the knuckle point.*

### **2.12.2**

*Ref. IMO Technical Provisions, Tab 2, 2.6  
(to Resolution MSC.158(78))*

*If no access holes are provided through the transverse ring webs within 600 mm of the tank base and the web frame rings have a web height greater than 1 m in way of side shell and sloping plating, then step rungs/grab rails are to be provided to allow safe access over each transverse web frame ring.*

### **2.12.3**

*Ref. IMO Technical Provisions, Tab 2, 2.7 (Resolution MSC.158(78))*

*For bilge hopper tanks of which the height is less than 6 m, alternative or a portable means may be utilized in lieu of the permanent means of access. Such means of access are to be demonstrated that they can be deployed and made readily available in the areas where needed.*

## **2.13 Access to fore peak tanks**

### **2.13.1**

*Ref. IMO Technical Provisions, Tab 2, 2.9 (Resolution MSC.158(78))*

*For fore peak tanks with a depth of 6 m or more at the centreline of the collision bulkhead, a suitable means of access is to be provided for access to critical areas such as the underdeck structure, stringers, collision bulkhead and side shell structure.*

### **2.13.2**

*Ref. IMO Technical Provisions, Tab 2, 2.9.1  
(Resolution MSC.158(78))*

*Stringers of less than 6 m in vertical distance from the deck head or a stringer immediately above are considered to provide suitable access in combination with portable means of access.*

### **2.13.3**

*Ref. IMO Technical Provisions, Tab 2, 2.9.2  
(Resolution MSC.158(78))*

*In case the vertical distance between the deck head and stringers, stringers or the lowest stringer and the tank bottom is 6 m or more, alternative means of access are to be provided.*

## **3 Shaft tunnels**

### **3.1 General**

#### **3.1.1**

Tunnels are to be large enough to ensure easy access to shafting.

#### **3.1.2**

Access to the tunnel is to be provided by a watertight door fitted on the aft bulkhead of the engine room in compliance with Ch 2, Sec 1, [6], and an escape trunk which can also act as watertight ventilator is to be fitted

up to the subdivision deck, for tunnels greater than 7 m in length.

## **4 Access to steering gear compartment**

### **4.1 General**

#### **4.1.1**

The steering gear compartment is to be readily accessible and, as far as practicable, separated from machinery spaces.

#### **4.1.2**

Suitable arrangements to ensure working access to steering gear machinery and controls are to be provided.

These arrangements are to include handrails and gratings or other non-slip surfaces to ensure suitable working conditions in the event of hydraulic fluid leakage.



# **Chapter 3**

## **Structural Design Principles**

---

Section 1    Material

Section 2    Net Scantling Approach

Section 3    Corrosion Additions

Section 4    Limit States

Section 5    Corrosion Protection

Section 6    Structural Arrangements Principles



## SECTION 1 MATERIAL

### 1 General

#### 1.1 Standard of material

##### 1.1.1

The requirements in this Section are intended for ships of welded construction using steels having characteristics complying with the Society Rules for Materials.

##### 1.1.2

Materials with different characteristics may be accepted, provided their specification (manufacture, chemical composition, mechanical properties, welding, etc.) is submitted to the Society for approval.

#### 1.2 Testing of materials

##### 1.2.1

Materials are to be tested in compliance with the applicable requirements of Society Rules for Materials.

#### 1.3 Manufacturing processes

##### 1.3.1

The requirements of this Section presume that welding and other cold or hot manufacturing processes are carried out in compliance with current sound working practice defined in IACS UR W and the applicable requirements of Society Rules for Materials. In particular:

- parent material and welding processes are to be within the limits stated for the specified type of material for which they are intended
- specific preheating may be required before welding
- welding or other cold or hot manufacturing processes may need to be followed by an adequate heat treatment.

## 2 Hull structural steel

### 2.1 General

#### 2.1.1

Table 1 gives the mechanical characteristics of steels currently used in the construction of ships.

<b>Table 1 Mechanical properties of hull steels</b>		
<i>Steel grades for plates with <math>t \leq 100</math> mm</i>	<i>Minimum yield stress <math>R_{eH}</math> in <math>N/mm^2</math></i>	<i>Ultimate tensile strength <math>R_m</math> in <math>N/mm^2</math></i>
<i>A-B-D-E</i>	235	400 – 520
<i>AH32-DH32-EH32-FH32</i>	315	440 – 570
<i>AH36-DH36-EH36-FH36</i>	355	490 – 630
<i>AH40-DH40-EH40-FH40</i>	390	510 – 660

#### 2.1.2

Where higher strength steels are to be used for hull construction, the drawings showing the scope and locations of the used place together with the type and scantlings are to be submitted for the approval of the Society.

#### 2.1.3

Higher strength steels other than those indicated in Table 1 are considered by the Society on a case by case basis.

### 2.1.4

When steels with a minimum guaranteed yield stress  $R_{eH}$  other than 235 N/mm<sup>2</sup> are used on a ship, hull scantlings are to be determined by taking into account the material factor  $k$  defined in [2.2].

### 2.1.5

It is required to keep on board a plan indicating the steel types and grades adopted for the hull structures. Where steels other than those indicated in Table 1 are used, their mechanical and chemical properties, as well as any workmanship requirements or recommendations, are to be available on board together with the above plan.

## 2.2 Material factor $k$

### 2.2.1

Unless otherwise specified, the material factor  $k$  of normal and higher strength steel for scantling purposes is to be taken as defined in Table 2, as a function of the minimum yield stress  $R_{eH}$ .

For intermediate values of  $R_{eH}$ ,  $k$  may be obtained by linear interpolation.

Steels with a yield stress greater than 390 N/mm<sup>2</sup> are considered by the Society on a case by case basis.

Minimum yield stress $R_{eH}$ , in N/mm <sup>2</sup>	$k$
235	1.0
315	0.78
355	0.72
390	0.68

## 2.3 Grades of steel

### 2.3.1

Steel materials in the various strength members are not to be of lower grade than those corresponding to classes I, II and III, as given in Table 3 for the material classes and grades given in Table 4-1, while additional requirements for ships with length (L) exceeding 150 m and 250 m, BC-A and BC-B ships are given in Table 4-2 to Table 4-4.

For strength members not mentioned in Table 4-1 to Table 4-4, grade  $A/AH$  may be used.

Class	I		II		III	
	NSS	HSS	NSS	HSS	NSS	HSS
<i>As-built thickness (mm)</i>						
$t \leq 15$	A	AH	A	AH	A	AH
$15 < t \leq 20$	A	AH	A	AH	B	AH
$20 < t \leq 25$	A	AH	B	AH	D	DH
$25 < t \leq 30$	A	AH	D	DH	D	DH
$30 < t \leq 35$	B	AH	D	DH	E	EH
$35 < t \leq 40$	B	AH	D	DH	E	EH
$40 < t \leq 50$	D	DH	E	EH	E	EH

Notes:  
NSS = Normal strength steel  
HSS = Higher strength steel

<b>Table 4-1 Material Classes and Grades for ships in general</b>	
<i>Structural member category</i>	<i>Material class/grade</i>
<b>SECONDARY:</b>	
A1 Longitudinal bulkhead strakes, other than that belonging to the Primary category	- Class I within 0.4L amidships - Grade A/AH outside 0.4L amidships
A2 Deck plating exposed to weather, other than that belonging to the Primary or Special category	
A3 Side plating	
<b>PRIMARY:</b>	
B1 Bottom plating, including keel plate	- Class II within 0.4L amidships - Grade A/AH outside 0.4L amidships
B2 Strength deck plating, excluding that belonging to the Special category	
B3 Continuous longitudinal members above strength deck, excluding hatch coamings.	
B4 Uppermost strake in longitudinal bulkhead	
B5 Vertical strake (hatch side girder) and uppermost sloped strake in top wing tank	
<b>SPECIAL:</b>	
C1. Sheer strake at strength deck <sup>(1)</sup>	- Class III within 0.4L amidships - Class II outside 0.4L amidships - Class I outside 0.6L amidships
C2 Stringer plate in strength deck <sup>(1)</sup>	
C3 Deck strake at longitudinal bulkhead, excluding deck plating in way of inner-skin bulkhead of double-hull ships <sup>(1)</sup>	
C5 Strength deck plating at corners of cargo hatch openings	- Class III within 0.6L amidships - Class II within rest of cargo region
C6 Bilge strake in ships with double bottom over the full breadth and length less than 150 m <sup>(1)</sup>	- Class II within 0.6L amidships - Class I outside 0.6L amidships
C7 Bilge strake in other ships <sup>(1)</sup>	- Class III within 0.4L amidships - Class II outside 0.4L amidships - Class I outside 0.6L amidships
C8 Longitudinal hatch coamings of length greater than 0.15L	- Class III within 0.4L amidships - Class II outside 0.4L amidships - Class I outside 0.6L amidships - Not to be less than Grade D/DH
C9 End brackets and deck house transition of longitudinal cargo hatch coamings <sup>(2)</sup>	
<sup>(1)</sup> Single strakes required to be of Class III within 0.4L amidships are to have breadths not less than 800+5L (mm), and need not be greater than 1800 (mm), unless limited by the geometry of the ship's design.	
<sup>(2)</sup> Applicable to bulk carriers having the longitudinal hatch coaming of length greater than 0.15L.	

<b>Table 4-2 Minimum material grades for ships with ship's length (L) exceeding 150 m and single strength deck</b>	
<i>Structural member category</i>	<i>Material Grade</i>
Longitudinal strength members of strength deck plating	Grade B/AH within 0.4L amidships
Continuous longitudinal strength members above strength deck	Grade B/AH within 0.4L amidships
Single side strakes for ships without inner continuous longitudinal bulkheads between bottom and the strength deck	Grade B/AH within cargo region

<b>Table 4-3 Minimum Material Grades for ships with ship's length (L) exceeding 250 m</b>	
<i>Structural member category</i>	<i>Material Grade</i>
Shear strake at strength deck <sup>(1)</sup>	Grade E/EH within 0.4L amidships
Stringer plate in strength deck <sup>(1)</sup>	Grade E/EH within 0.4L amidships
Bilge strake <sup>(1)</sup>	Grade D/DH within 0.4L amidships
<sup>(1)</sup> Single strakes required to be of Class III within 0.4L amidships are to have breadths not less than 800 + 5L (mm), and need not be greater than 1800 (mm), unless limited by the geometry of the ship's design	

Table 4-4 Minimum material grades for BC-A and BC-B ships	
<i>Structural member category</i>	<i>Material Grade</i>
Lower bracket of ordinary side frame <sup>(1), (2)</sup>	Grade D/DH
Side shell strakes included totally or partially between the two points located to 0.125 <i>l</i> above and below the intersection of side shell and bilge hopper sloping plate or inner bottom plate <sup>(2)</sup>	Grade D/DH
(1) The term “lower bracket” means webs of lower brackets and webs of the lower part of side frames up to the point 0.125 <i>l</i> above the intersection of side shell and bilge hopper sloping plate or inner bottom plate.	
(2) The span of the side frame, <i>l</i> , is defined as the distance between the supporting structure (See Ch.3 Sec.6 Fig.19)	

### 2.3.2

Plating materials for stern frames, rudders, rudder horns and shaft brackets are in general not to be of lower grades than corresponding to class II. For rudder and rudder body plates subjected to stress concentrations (e.g. in way of lower support of semi-spade rudders or at upper part of spade rudders) class III is to be applied.

### 2.3.3

Bedplates of seats for propulsion and auxiliary engines inserted in the inner bottom within 0.6*L* amidships are to be of class I. In other cases, the steel is to be at least of grade A/AH.

### 2.3.4

(void)

### 2.3.5

The steel grade is to correspond to the as-built thickness.

### 2.3.6

Steel grades of plates or sections of as-built thickness greater than the limiting thicknesses in Table 3 are considered by the Society on a case by case basis.

### 2.3.7

In specific cases, such as [2.3.8], with regard to stress distribution along the hull girder, the classes required within 0.4*L* amidships may be extended beyond that zone, on a case by case basis.

### 2.3.8

The material classes required for the strength deck plating, the sheerstrake and the upper strake of longitudinal bulkheads within 0.4*L* amidships are to be maintained for an adequate length across the poop front and at the ends of the bridge, where fitted.

### 2.3.9

Rolled products used for welded attachments of length greater than 0.15*L* on outside of hull plating, such as gutter bars, are to be of the same grade as that used for the hull plating in way.

### 2.3.10

In the case of full penetration welded joints located in positions where high local stresses may occur perpendicular to the continuous plating, the Society may, on a case by case basis, require the use of rolled products having adequate ductility properties in the through thickness direction, such as to prevent the risk of lamellar tearing (*Z* type steel).

## 2.4 Structures exposed to low air temperature

### 2.4.1

The application of steels for ships designed to operate in area with low air temperatures is to comply with [2.4.2] to [2.4.6].

### 2.4.2

For ships intended to operate in areas with low air temperatures (below and including  $-20^{\circ}\text{C}$ ), e.g. regular service during winter seasons to Arctic or Antarctic waters, the materials in exposed structures are to be selected based on the design temperature  $t_D$ , to be taken as defined in [2.4.3].

### 2.4.3

The design temperature  $t_D$  is to be taken as the lowest mean daily average air temperature in the area of operation, where:

- Mean = Statistical mean over observation period (at least 20 years).
- Average = Average during one day and night.
- Lowest = Lowest during year.

Fig 1 illustrates the temperature definition for Arctic waters.

For seasonally restricted service the lowest value within the period of operation applies.

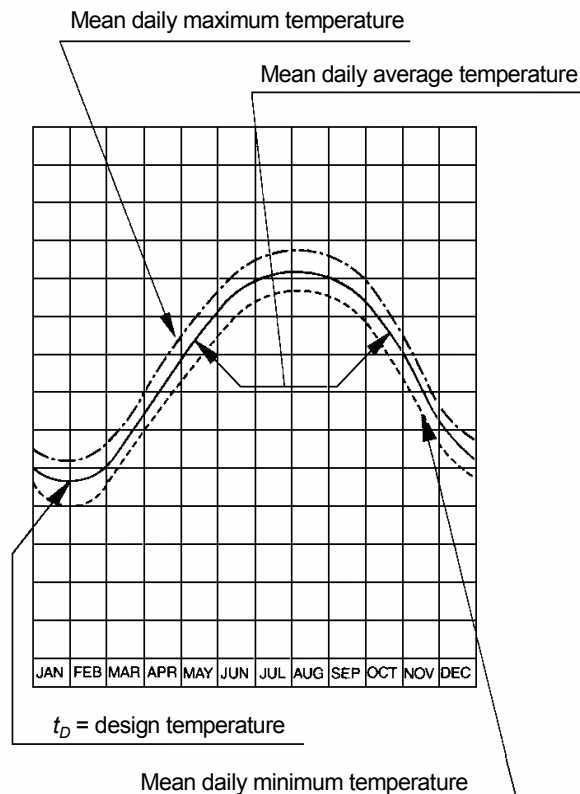

**Fig. 1**  
Commonly used definitions of temperatures

### 2.4.4

Materials in the various strength members above the lowest ballast water line (BWL) exposed to air are not to be of lower grades than those corresponding to classes I, II and III as given in Table 5 depending on the categories of structural members (SECONDARY, PRIMARY and SPECIAL).

For non-exposed structures and structures below the lowest ballast water line, see [2.3]

### 2.4.5

The material grade requirements for hull members of each class depending on thickness and design temperature are defined in Table 6, Table 7 and Table 8. For design temperatures  $t_D < -55^\circ\text{C}$ , materials are to be specially considered by the Society.

### 2.4.6

Single strakes required to be of class III or of grade *E/EH* and *FH* are to have breadths not less than the values, in m, given by the following formula, but need not to be greater than 1.8 m:

$$b = 0.005L + 0.8$$

<b>Table 5 Application of material classes and grades - Structures exposed at low temperature</b>		
Structural member category	Material class	
	Within 0.4L amidship	Outside 0.4L amidship
<b>SECONDARY</b>		
Deck plating exposed to weather, in general	I	I
Side plating above BWL		
Transverse bulkheads above BWL		
<b>PRIMARY</b>		
Strength deck plating <sup>(1)</sup>	II	I
Continuous longitudinal members above strength deck, excluding longitudinal hatch coamings		
Longitudinal bulkhead above BWL		
Top wing tank bulkhead above BWL		
<b>SPECIAL</b>		
Sheer strake at strength deck <sup>(2)</sup>	III	II
Stringer plate in strength deck <sup>(2)</sup>		
Deck strake at longitudinal bulkhead <sup>(3)</sup>		
Continuous longitudinal hatch coamings <sup>(4)</sup>		
Notes:		
1) Plating at corners of large hatch openings to be specially considered. Class III or grade E/EH to be applied in positions where high local stresses may occur.		
2) Not to be less than grade E/EH within 0.4L amidships in ships with length exceeding 250 m.		
3) In ships with a breadth exceeding 70 m at least three deck strakes to be class III.		
4) Not to be less than grade D/DH.		

<b>Table 6 Material grade requirements for class I at low temperature</b>								
As-built thickness (mm)	-20 / -25°C		-26 / -35°C		-36 / -45°C		-45 / -55°C	
	NSS	HSS	NSS	HSS	NSS	HSS	NSS	HSS
$t \leq 10$	A	AH	B	AH	D	DH	D	DH
$10 < t \leq 15$	B	AH	D	DH	D	DH	D	DH
$15 < t \leq 20$	B	AH	D	DH	D	DH	E	EH
$20 < t \leq 25$	D	DH	D	DH	D	DH	E	EH
$25 < t \leq 30$	D	DH	D	DH	E	EH	E	EH
$30 < t \leq 35$	D	DH	D	DH	E	EH	E	EH
$35 < t \leq 45$	D	DH	E	EH	E	EH	-	FH
$45 < t \leq 50$	E	EH	E	EH	-	FH	-	FH
Note: "NSS" and "HSS" mean, respectively "Normal Strength Steel" and "Higher Strength Steel"								

<b>Table 7 Material grade requirements for class II at low temperature</b>								
As-built thickness (mm)	-20 / -25°C		-26 / -35°C		-36 / -45°C		-45 / -55°C	
	NSS	HSS	NSS	HSS	NSS	HSS	NSS	HSS
$t \leq 10$	B	AH	D	DH	D	DH	E	EH
$10 < t \leq 20$	D	DH	D	DH	E	EH	E	EH
$20 < t \leq 30$	D	DH	E	EH	E	EH	-	FH
$30 < t \leq 40$	E	EH	E	EH	-	FH	-	FH
$40 < t \leq 45$	E	EH	-	FH	-	FH	-	-
$45 < t \leq 50$	E	EH	-	FH	-	FH	-	-
Note: "NSS" and "HSS" mean, respectively "Normal Strength Steel" and "Higher Strength Steel"								



<i>As-built thickness (mm)</i>	<i>-20 / -25°C</i>		<i>-26 / -35°C</i>		<i>-36 / -45°C</i>		<i>-45 / -55°C</i>	
	<i>NSS</i>	<i>HSS</i>	<i>NSS</i>	<i>HSS</i>	<i>NSS</i>	<i>HSS</i>	<i>NSS</i>	<i>HSS</i>
$t \leq 10$	<i>D</i>	<i>DH</i>	<i>D</i>	<i>DH</i>	<i>E</i>	<i>EH</i>	<i>E</i>	<i>EH</i>
$10 < t \leq 20$	<i>D</i>	<i>DH</i>	<i>E</i>	<i>EH</i>	<i>E</i>	<i>EH</i>	-	<i>FH</i>
$20 < t \leq 25$	<i>E</i>	<i>EH</i>	<i>E</i>	<i>EH</i>	-	<i>FH</i>	-	<i>FH</i>
$25 < t \leq 30$	<i>E</i>	<i>EH</i>	<i>E</i>	<i>EH</i>	-	<i>FH</i>	-	<i>FH</i>
$30 < t \leq 40$	<i>E</i>	<i>EH</i>	-	<i>FH</i>	-	<i>FH</i>	-	-
$40 < t \leq 45$	<i>E</i>	<i>EH</i>	-	<i>FH</i>	-	<i>FH</i>	-	-
$45 < t \leq 50$	-	<i>FH</i>	-	<i>FH</i>	-	-	-	-

Note: "NSS" and "HSS" mean, respectively "Normal Strength Steel" and "Higher Strength Steel"

### 3 Steels for forging and casting

#### 3.1 General

##### 3.1.1

Mechanical and chemical properties of steels for forging and casting to be used for structural members are to comply with the applicable requirements of the Society Rules for Materials.

##### 3.1.2

Steels of structural members intended to be welded are to have mechanical and chemical properties deemed appropriate for this purpose by the Society on a case by case basis.

##### 3.1.3

The steels used are to be tested in accordance with the applicable requirements of the Society Rules for Materials.

#### 3.2 Steels for forging

##### 3.2.1

Rolled bars may be accepted in lieu of forged products, after consideration by the Society on a case by case basis.

In such case, compliance with the applicable requirements of the Society Rules for Materials, relevant to the quality and testing of rolled parts accepted in lieu of forged parts, may be required.

#### 3.3 Steels for casting

##### 3.3.1

Cast parts intended for stems, sternframes, rudders, parts of steering gear and deck machinery in general may be made of C and C-Mn weldable steels, having specified minimum tensile strength  $R_m = 400 \text{ N/mm}^2$  or  $440 \text{ N/mm}^2$ , in accordance with the applicable requirements of the Society Rules for Materials.

##### 3.3.2

The welding of cast parts to main plating contributing to hull strength members is considered by the Society on a case by case basis.

The Society may require additional properties and tests for such casting, in particular impact properties which are appropriate to those of the steel plating on which the cast parts are to be welded and non-destructive examinations.

##### 3.3.3

Heavily stressed cast parts of steering gear, particularly those intended to form a welded assembly and tillers or rotors mounted without key, are to be subjected to surface and volumetric non-destructive examination to check their internal structure.

## 4 Aluminium alloy structures

### 4.1 General

#### 4.1.1

The characteristics of aluminium alloys are to comply with the requirements of the Society Rules for Materials. Series 5000 aluminium-magnesium alloys or series 6000 aluminium-magnesium-silicon alloys are to be used.

#### 4.1.2

In the case of structures subjected to low service temperatures or intended for other specific applications, the alloys to be employed are to be agreed by the Society.

#### 4.1.3

Unless otherwise agreed, the Young's modulus for aluminium alloys is equal to 70000 N/mm<sup>2</sup> and the Poisson's ratio equal to 0.33.

### 4.2 Extruded plating

#### 4.2.1

Extrusions with built-in plating and stiffeners, referred to as extruded plating, may be used.

#### 4.2.2

In general, the application is limited to decks, bulkheads, superstructures and deckhouses. Other uses may be permitted by the Society on a case by case basis.

#### 4.2.3

Extruded plating is to be oriented so that the stiffeners are parallel to the direction of main stresses.

#### 4.2.4

Connections between extruded plating and primary members are to be given special attention.

### 4.3 Mechanical properties of weld joints

#### 4.3.1

Welding heat input lowers locally the mechanical strength of aluminium alloys hardened by work hardening (series 5000 other than condition O or H111) or by heat treatment (series 6000).

#### 4.3.2

The as-welded properties of aluminium alloys of series 5000 are in general those of condition O or H111. Higher mechanical characteristics may be taken into account, provided they are duly justified.

#### 4.3.3

The as-welded properties of aluminium alloys of series 6000 are to be agreed by the Society.

### 4.4 Material factor $k$

#### 4.4.1

The material factor  $k$  for aluminium alloys is to be obtained from the following formula:

$$k = \frac{235}{R'_{lim}}$$

where:

$R'_{lim}$  = Minimum guaranteed yield stress of the parent metal in welded condition  $R'_{p0.2}$ , in N/mm<sup>2</sup>, but not to be taken greater than 70% of the minimum guaranteed tensile strength of the parent metal in welded condition  $R'_m$ , in N/mm<sup>2</sup>

$R'_{p0.2}$  =  $\eta_1 R_{p0.2}$

$R'_m$  =  $\eta_2 R_m$

$R_{p0.2}$  = Minimum guaranteed yield stress, in N/mm<sup>2</sup>, of the parent metal in delivery condition

$R_m$  = Minimum guaranteed tensile strength, in N/mm<sup>2</sup>, of the parent metal in delivery condition  
 $\eta_1, \eta_2$  = Specified in Table 9.

#### 4.4.2

In the case of welding of two different aluminium alloys, the material factor  $k$  to be considered for the scantlings is the greater material factor of the aluminium alloys of the assembly.

<b>Table 9 Aluminium alloys for welded construction</b>		
<i>Aluminium alloy</i>	$\eta_1$	$\eta_2$
Alloys without work-hardening treatment (series 5000 in annealed condition O or annealed flattened condition H111)	1	1
Alloys hardened by work hardening (series 5000 other than condition O or H111)	$R'_{p0.2} / R_{p0.2}$	$R'_m / R_m$
Alloys hardened by heat treatment (series 6000) <sup>(1)</sup>	$R'_{p0.2} / R_{p0.2}$	0.6
Notes:		
(1) = When no information is available, coefficient $\eta_1$ is to be taken equal to the metallurgical efficiency coefficient $\beta$ defined in Table 10.		
$R'_{p0.2}$ = Minimum guaranteed yield stress, in N/mm <sup>2</sup> , of material in welded condition		
$R'_m$ = Minimum guaranteed tensile strength, in N/mm <sup>2</sup> , of material in welded condition		

<b>Table 10 Aluminium alloys - Metallurgical efficiency coefficient <math>\beta</math></b>			
<i>Aluminium alloy</i>	<i>Temper condition</i>	<i>Gross thickness, in mm</i>	$\beta$
6005 A (Open sections)	T5 or T6	$t \leq 6$	0.45
		$t > 6$	0.40
6005 A (Closed sections)	T5 or T6	All	0.50
6061 (Sections)	T6	All	0.53
6082 (Sections)	T6	All	0.45

## 5 Other materials and products

### 5.1 General

#### 5.1.1

Other materials and products such as parts made of iron castings, where allowed, products made of copper and copper alloys, rivets, anchors, chain cables, cranes, masts, derrick posts, derricks, accessories and wire ropes are to comply with the applicable requirements of the Society Rules for Materials.

#### 5.1.2

The use of plastics or other special materials not covered by these Rules is to be considered by the Society on a case by case basis. In such cases, the requirements for the acceptance of the materials concerned are to be agreed by the Society.

#### 5.1.3

Materials used in welding processes are to comply with the applicable requirements of the Society Rules for Materials.

### 5.2 Iron cast parts

#### 5.2.1

As a rule, the use of grey iron, malleable iron or spheroidal graphite iron cast parts with combined ferritic/perlitic structure is allowed only to manufacture low stressed elements of secondary importance.

#### 5.2.2

Ordinary iron cast parts may not be used for windows or sidescuttles; the use of high grade iron cast parts of a suitable type will be considered by the Society on a case by case basis.

## SECTION 2 NET SCANTLING APPROACH

### Symbols

$t_{as\_built}$	= <i>As-built Thickness</i> : the actual thickness, in mm, provided at the newbuilding stage, including $t_{voluntary\_addition}$ , if any.
$t_C$	= <i>Corrosion Addition Thickness</i> : as defined in Ch 3, Sec 3, in mm.
$t_{gross\_offered}$	= <i>Gross Thickness Offered</i> : the actual gross (full) thickness, in mm, provided at the newbuilding stage, excluding $t_{voluntary\_addition}$ , the owner's extra margin for corrosion wastage, if any.
$t_{gross\_required}$	= <i>Gross Thickness Required</i> : the gross (full) thickness, in mm, obtained by adding $t_C$ to the Net Thickness Required.
$t_{net\_offered}$	= <i>Net Thickness Offered</i> : the net thickness, in mm, obtained by subtracting $t_C$ from the Gross Thickness Offered
$t_{net\_required}$	= <i>Net Thickness Required</i> : the net thickness, in mm, as required by the Rules that satisfy all the structural strength requirements, rounded to the closest half millimetre.
$t_{voluntary\_addition}$	= <i>Thickness for Voluntary Addition</i> : the thickness, in mm, voluntarily added as the owner's extra margin for corrosion wastage in addition to $t_C$ .

## 1 General philosophy

### 1.1

#### 1.1.1

Net Scantling Approach is to clearly specify the “net scantling” that is to be maintained right from the newbuilding stage throughout the ship's design life to satisfy the structural strength requirements. This approach clearly separates the net thickness from the thickness added for corrosion that is likely to occur during the ship-in-operation phase.

## 2 Application criteria

### 2.1 General

#### 2.1.1

The scantlings obtained by applying the criteria specified in this Rule are net scantlings as specified in [3.1] to [3.3]; i.e. those which provide the strength characteristics required to sustain the loads, excluding any addition for corrosion and voluntarily added thickness such as the owner's extra margin, if any. The following gross offered scantlings are exceptions; i.e. they already include additions for corrosion but without voluntarily added values such as the owner's extra margin:

- scantlings of superstructures and deckhouses, according to Ch 9, Sec 4
- scantlings of rudder structures, according to Ch 10, Sec 1
- scantlings of massive pieces made of steel forgings, steel castings.

#### 2.1.2

The required strength characteristics are:

- thickness, for plating including that which constitutes primary supporting members
- section modulus, shear area, moments of inertia and local thickness for ordinary stiffeners and, as the case may be, primary supporting members
- section modulus, moments of inertia and first moment for the hull girder.

#### 2.1.3

The ship is to be built at least with the gross scantlings obtained by adding the corrosion additions, specified in Ch 3, Sec 3, to the net scantlings. The thickness for voluntary addition is to be added as an extra.

### 3 Net scantling approach

#### 3.1 Net scantling definition

##### 3.1.1 Required thickness

The gross thickness required,  $t_{gross\_required}$ , is not less than the gross thickness which is obtained by adding the corrosion addition  $t_C$  as defined in Ch 3, Sec 3 to net thickness required, as follows:

$$t_{gross\_required} = t_{net\_required} + t_C$$

##### 3.1.2 Offered thickness

The gross thickness offered,  $t_{gross\_offered}$ , is the gross thickness provided at the newbuilding stage, which is obtained by deducting the thickness for voluntary addition from the as-built thickness, as follows:

$$t_{gross\_offered} = t_{as\_built} - t_{voluntary\_addition}$$

##### 3.1.3 Net thickness for plate

Net thickness offered,  $t_{net\_offered}$ , is obtained by subtracting  $t_C$  from the gross thickness offered, as follows:

$$t_{net\_offered} = t_{gross\_offered} - t_C = t_{as\_built} - t_{voluntary\_addition} - t_C$$

##### 3.1.4 Net section modulus for stiffener

The net transverse section scantling is to be obtained by deducting  $t_C$  from the gross thickness offered of the elements which constitute the stiffener profile as shown in Fig.1.

For bulb profiles, an equivalent angle profile, as specified in Ch 3, Sec 6, [4.1.1], may be considered.

The net strength characteristics are to be calculated for the net transverse section.

In assessing the net strength characteristics of stiffeners reflecting the hull girder stress and stress due to local bending of the local structure such as double bottom structure, the section modulus of hull girder or rigidity of structure is obtained by deducting  $0.5t_C$  from the gross thickness offered of the related elements.

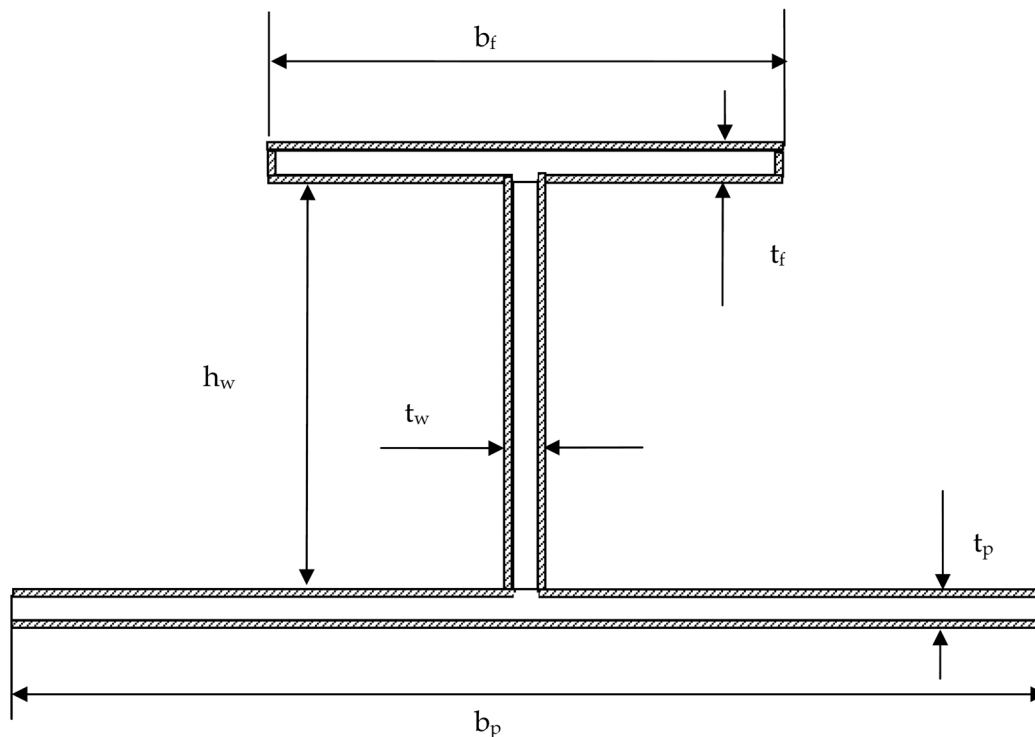

Shadow area is corrosion addition.

For attached plate, the half of the considered corrosion addition specified in 3.2 is deducted from both sides of the attached plate.

**Fig. 1**  
Net scantling of stiffener

## **3.2 Considered net scantling**

### **3.2.1 Yielding check of the hull girder**

The net thickness of structural members to be considered for the yielding check of the hull girder, according to Ch 5, Sec 1, is to be obtained by deducting  $0.5t_C$  from the gross thickness offered.

### **3.2.2 Global stress such as stress due to hull girder bending moment and shear force**

The net thickness of structural members to be considered for stress due to hull girder bending moment and shear force according to Ch 5, Sec 1, is to be obtained by deducting  $0.5t_C$  from the gross thickness offered.

### **3.2.3 Buckling check of the hull girder**

The net thickness of structural members to be considered for the buckling check, according to Ch 6, Sec 3, is to be obtained by deducting  $t_C$  from the gross thickness offered.

### **3.2.4 Ultimate strength check of the hull girder**

The net thickness of structural members to be considered for the ultimate strength check of the hull girder, according to Ch 5, Sec 2, is to be obtained by deducting  $0.5t_C$  from the gross thickness offered.

### **3.2.5 Direct strength analysis**

The net thickness of plating which constitutes primary supporting members to be checked stresses according to Ch 7 is to be obtained by deducting  $0.5t_C$  from the gross thickness offered.

The net thickness of plating members to be considered for the buckling check according to Ch 6, Sec 3, using the stresses obtained from direct strength analysis, is to be obtained by deducting  $t_C$  from the gross thickness offered.

### **3.2.6 Fatigue check**

The net thickness of structural members to be checked for fatigue according to Ch 8 is to be obtained by deducting  $0.5t_C$  from the gross thickness offered.

### **3.2.7 Check of primary supporting members for ships less than 150 m in length L**

The net thickness of plating which constitutes primary supporting members for ships less than 150 m in length  $L$ , to be checked according to Ch.6, Sec.4, [2], is to be obtained by deducting  $t_c$  from the gross thickness.

## **3.3 Available information on structural drawings**

### **3.3.1**

The structural drawings are to indicate for each structural element the gross scantling and the renewal thickness as specified in Ch 13, Sec 2.

If thickness for voluntary addition is included in the as-built thicknesses, this is to be clearly mentioned and identified on the drawings.

## SECTION 3 CORROSION ADDITIONS

### Symbols

- $t_C$  = Total corrosion addition, in mm, defined in [1.2]  
 $t_{C1}, t_{C2}$  = Corrosion addition, in mm, on one side of the considered structural member, defined in Table 1  
 $t_{reserve}$  = Reserve thickness, in mm, defined in Ch 13, Sec 2 and taken equal to:

$$t_{reserve} = 0.5$$

### 1 Corrosion additions

#### 1.1 General

##### 1.1.1

The values of the corrosion additions specified in this section are to be applied in relation with the relevant protective coatings required by Sec 5.

For materials different from carbon steel, special consideration is to be given to the corrosion addition.

#### 1.2 Corrosion addition determination

##### 1.2.1 Corrosion additions for steel

The corrosion addition for each of the two sides of a structural member,  $t_{C1}$  or  $t_{C2}$ , is specified in Table 1.

The total corrosion addition  $t_C$ , in mm, for both sides of the structural member is obtained by the following formula:

$$t_C = \text{Roundup}_{0.5}(t_{C1} + t_{C2}) + t_{reserve}$$

For an internal member within a given compartment, the total corrosion addition  $t_C$  is obtained from the following formula:

$$t_C = \text{Roundup}_{0.5}(2t_{C1}) + t_{reserve}$$

where  $t_{C1}$  is the value specified in Table 1 for one side exposure to that compartment.

When a structural member is affected by more than one value of corrosion addition (e.g. a plate in a dry bulk cargo hold extending above the lower zone), the scantling criteria are generally to be applied considering the severest value of corrosion addition applicable to the member.

In addition, the total corrosion addition  $t_C$  is not to be taken less than 2 mm, except for web and face plate of ordinary stiffeners.

##### 1.2.2 Corrosion additions for aluminium alloys

For structural members made of aluminium alloys, the corrosion addition  $t_C$  is to be taken equal to 0.

<b>Table 1 Corrosion addition on one side of structural members</b>				
<i>Compartment Type</i>	<i>Structural member</i>		<i>Corrosion addition, <math>t_{C1}</math> or <math>t_{C2}</math> in mm</i>	
			<b>BC-A or BC-B</b> <i>ships with <math>L \geq 150</math> m</i>	<i>Other</i>
Ballast water tank (2)	Face plate of primary members	Within 3 m below the top of tank (3)	2.0	
		Elsewhere	1.5	
	Other members	Within 3 m below the top of tank (3)	1.7	
		Elsewhere	1.2	

<b>Table 1 Corrosion addition on one side of structural members (Continued)</b>				
Compartment Type	Structural member		Corrosion addition, $t_{C1}$ or $t_{C2}$ in mm	
			BC-A or BC-B ships with $L \geq 150$ m	Other
Dry bulk cargo hold <sup>(1)</sup>	Transverse bulkhead	Upper part <sup>(4)</sup>	2.4	1.0
		Lower stool: sloping plate, vertical plate and top plate	5.2	2.6
		Other parts	3.0	1.5
	Other members	Upper part <sup>(4)</sup>	1.8	1.0
		Webs and flanges of the upper end brackets of side frames of single side bulk carriers		
		Webs and flanges of lower brackets of side frames of single side bulk carriers	2.2	1.2
		Other parts	2.0	1.2
	Sloped plating of hopper tank, inner bottom plating	Continuous wooden ceiling	2.0	1.2
		No continuous wooden ceiling	3.7	2.4
Exposed to atmosphere	Horizontal member and weather deck <sup>(5)</sup>		1.7	
	Non horizontal member		1.0	
Exposed to sea water <sup>(7)</sup>			1.0	
Fuel oil tanks and lubricating oil tanks <sup>(2)</sup>			0.7	
Fresh water tanks			0.7	
Void spaces <sup>(6)</sup>	Spaces not normally accessed, e.g. access only through bolted manholes openings, pipe tunnels, etc.		0.7	
Dry spaces	Internal of deck houses, machinery spaces, stores spaces, pump rooms, steering spaces, etc.		0.5	
Other compartments than above			0.5	
Notes				
1) Dry bulk cargo hold includes holds, intended for the carriage of dry bulk cargoes, which may carry water ballast.				
2) The corrosion addition of a plating between water ballast and heated fuel oil tanks is to be increased by 0.7 mm.				
3) This is only applicable to ballast tanks with weather deck as the tank top.				
4) Upper part of the cargo holds corresponds to an area above the connection between the top side and the inner hull or side shell. If there is no top side, the upper part corresponds to the upper one third of the cargo hold height.				
5) Horizontal member means a member making an angle up to 20° as regard as a horizontal line.				
6) The corrosion addition on the outer shell plating in way of pipe tunnel is to be considered as water ballast tank.				
7) Outer side shell between normal ballast draught and scantling draught is to be increased by 0.5 mm				



## SECTION 4 LIMIT STATES

### 1 General

#### 1.1 General principle

##### 1.1.1

The structural strength assessments indicated in Table 1 are covered by the requirements of the present Rules.

		<i>Yielding check</i>	<i>Buckling check</i>	<i>Ultimate strength check</i>	<i>Fatigue check</i>
Local Structures	Ordinary stiffeners	✓	✓	✓ (1)	✓ (2)
	Plating subjected to lateral pressure	✓	✓	✓ (3)	—
Primary supporting members		✓	✓	✓	✓ (2)
Hull girder		✓	✓ (4)	✓	—
<p>Note: ✓ indicates that the structural assessment is to be carried out.</p> <p>1) The ultimate strength check of stiffeners is included in the buckling check of stiffeners.</p> <p>2) The fatigue check of stiffeners and primary supporting members is the fatigue check of connection details of these members.</p> <p>3) The ultimate strength check of plating is included in the yielding check formula of plating.</p> <p>4) The buckling check of stiffeners and plating taking part in hull girder strength is performed against stress due to hull girder bending moment and hull girder shear force.</p>					

##### 1.1.2

Strength of hull structures in flooded condition is to be assessed.

#### 1.2 Limit states

##### 1.2.1 Serviceability limit state

Serviceability limit state, which concerns the normal use, includes:

- local damage which may reduce the working life of the structure or affect the efficiency or appearance of structural members
- unacceptable deformations which affect the efficient use and appearance of structural members or the functioning of equipment.

##### 1.2.2 Ultimate limit state

Ultimate limit state, which corresponds to the maximum load-carrying capacity, or in some cases, the maximum applicable strain or deformation, includes:

- attainment of the maximum resistance capacity of sections, members or connections by rupture or excessive deformations
- instability of the whole structure or part of it.

##### 1.2.3 Fatigue limit state

Fatigue limit state relate to the possibility of failure due to cyclic loads.

##### 1.2.4 Accidental limit state

Accidental limit state considers the flooding of any one cargo hold without progression of the flooding to the other compartments and includes:

- the maximum load-carrying capacity of hull girder
- the maximum load-carrying capacity of double bottom structure
- the maximum load-carrying capacity of bulkhead structure

Accidental single failure of one structural member of any one cargo hold is considered in the assessment of the ultimate strength of the entire stiffened panel.

## **2 Strength criteria**

### **2.1 Serviceability limit states**

#### **2.1.1 Hull girder**

For the yielding check of the hull girder, the stress corresponds to a load at  $10^{-8}$  probability level.

#### **2.1.2 Plating**

For the yielding check and buckling check of platings constituting a primary supporting member, the stress corresponds to a load at  $10^{-8}$  probability level.

#### **2.1.3 Ordinary stiffener**

For the yielding check of an ordinary stiffener, the stress corresponds to a load at  $10^{-8}$  probability level.

### **2.2 Ultimate limit states**

#### **2.2.1 Hull girder**

The ultimate strength of the hull girder is to withstand the maximum vertical longitudinal bending moment obtained by multiplying the partial safety factor and the vertical longitudinal bending moment at  $10^{-8}$  probability level.

#### **2.2.2 Plating**

The ultimate strength of the plating between ordinary stiffeners and primary supporting members is to withstand the load at  $10^{-8}$  probability level.

#### **2.2.3 Ordinary stiffener**

The ultimate strength of the ordinary stiffener is to withstand the load at  $10^{-8}$  probability level.

### **2.3 Fatigue limit state**

#### **2.3.1 Structural details**

The fatigue life of representative structural details such as connections of ordinary stiffeners and primary supporting members is obtained from reference pressures at  $10^{-4}$ .

### **2.4 Accidental limit state**

#### **2.4.1 Hull girder**

Longitudinal strength of hull girder in cargo hold flooded condition is to be assessed in accordance with Ch 5, Sec 2.

#### **2.4.2 Double bottom structure**

Double bottom structure in cargo hold flooded condition is to be assessed in accordance with Ch 6, Sec 4.

#### **2.4.3 Bulkhead structure**

Bulkhead structure in cargo hold flooded condition is to be assessed in accordance with Ch 6, Sec 1, Sec 2 and Sec 3.

## **3 Strength check against impact loads**

### **3.1 General**

#### **3.1.1**

Structural response against impact loads such as forward bottom slamming, bow flare slamming and grab falling depends on the loaded area, magnitude of loads and structural grillage.

#### **3.1.2**

The ultimate strength of structural members that constitute the grillage, i.e. platings between ordinary stiffeners and primary supporting members and ordinary stiffeners with attached plating, is to withstand the maximum impact loads acting on them.

## SECTION 5 CORROSION PROTECTION

### 1 General

#### 1.1 Structures to be protected

##### 1.1.1

All seawater ballast tanks, cargo holds and ballast holds are to have a corrosion protective system fitted in accordance with [1.2], [1.3] and [1.4] respectively.

##### 1.1.2

Void double side skin spaces in cargo length area for vessels having a length ( $L_{LL}$ ) of not less than 150 m are to be coated in accordance with [1.2].

##### 1.1.3

Corrosion protective coating is not required for internal surfaces of spaces intended for the carriage of fuel oil.

##### 1.1.4

Narrow spaces are generally to be filled by an efficient protective product, particularly at the ends of the ship where inspections and maintenance are not easily practicable due to their inaccessibility.

#### 1.2 Protection of seawater ballast tanks and void double side skin spaces

##### 1.2.1

All dedicated seawater ballast tanks anywhere on the ship (excluding ballast hold) for vessels having a length (L) of not less than 90 m and void double side skin spaces in the cargo length area for vessels having a length ( $L_{LL}$ ) of not less than 150 m are to have an efficient corrosion prevention system, such as hard protective coatings or equivalent, applied in accordance with the manufacturer's recommendation.

The coatings are to be of a light colour, i.e. a colour easily distinguishable from rust which facilitates inspection.

Where appropriate, sacrificial anodes, fitted in accordance with [2], may also be used.

##### 1.2.2

For ships contracted for construction on or after the date of IMO adoption of the amended SOLAS regulation II-1/3-2, by which an IMO "Performance standard for protective coatings for ballast tanks and void spaces" will be made mandatory, the coatings of internal spaces subject to the amended SOLAS regulation are to satisfy the requirements of the IMO performance standard.

Consistent with IMO Resolution A.798(19) and IACS UI SC 122, the selection of the coating system, including coating selection, specification, and inspection plan, are to be agreed between the shipbuilder, coating system supplier and the owner, in consultation with the Society, prior to commencement of construction. The specification for the coating system for these spaces is to be documented and this documentation is to be verified by the Society and is to be in full compliance with the coating performance standard.

The shipbuilder is to demonstrate that the selected coating system with associated surface preparation and application methods is compatible with the manufacturing processes and methods.

The shipbuilder is to demonstrate that the coating inspectors have proper qualification as required by the IMO standard.

The attending surveyor of the Society will not verify the application of the coatings but will review the reports of the coating inspectors to verify that the specified shipyard coating procedures have been followed.

#### 1.3 Protection of cargo hold spaces

##### 1.3.1 Coating

It is the responsibility of the shipbuilder and of the owner to choose coatings suitable for the intended cargoes, in particular for the compatibility with the cargo.

### 1.3.2 Application

All internal and external surfaces of hatch coamings and hatch covers, and all internal surfaces of cargo holds (side and transverse bulkheads), excluding the inner bottom area and part of the hopper tank sloping plate and lower stool sloping plate, are to have an efficient protective coating, of an epoxy type or equivalent, applied in accordance with the manufacturer's recommendation.

The side and transverse bulkhead areas to be coated are specified in [1.3.3] and [1.3.4] respectively.

### 1.3.3 Side areas to be coated

The areas to be coated are the internal surfaces of:

- the inner side plating
- the internal surfaces of the topside tank sloping plates
- the internal surfaces of the hopper tank sloping plates for a distance of 300 mm below the frame end bracket for single side bulk carriers or below the hopper tank upper end for double side bulk carriers.

These areas are shown in Fig 1.

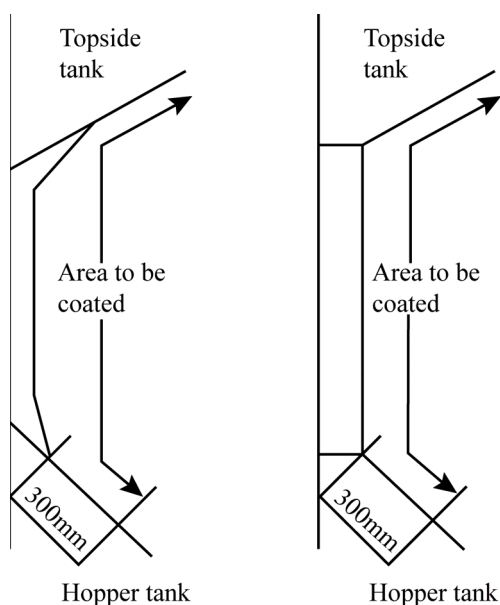

Fig. 1  
Side areas to be coated

### 1.3.4 Transverse bulkhead areas to be coated

The areas of transverse bulkheads to be coated are all the areas located above an horizontal level located at a distance of 300 mm below the frame end bracket for single side bulk carriers or below the hopper tank upper end for double side bulk carriers.

## 1.4 Protection of ballast hold spaces

### 1.4.1 Application

All internal and external surfaces of hatch coamings and hatch covers, and all internal surfaces of ballast holds are to have an effective protective coating, of an epoxy type or equivalent, applied in accordance with the manufacturer's recommendation.

## 2 Sacrificial anodes

### 2.1 General

#### 2.1.1

Anodes are to have steel cores and are to be fitted sufficiently rigid by the anode support designed so that they retain the anode even when it is wasted.

The steel inserts are to be attached to the structure by means of a continuous weld. Alternatively, they may be

attached to separate supports by bolting, provided a minimum of two bolts with lock nuts are used. However, other mechanical means of clamping may be accepted.

#### **2.1.2**

The supports at each end of an anode may not be attached to separate items which are likely to move independently.

#### **2.1.3**

Where anode inserts or supports are welded to the structure, the welds are to be smoothly.

### **3 Protection of inner bottom by ceiling**

#### **3.1 General**

##### **3.1.1**

Ceiling on the inner bottom, if any, is to comply with [3.2] and [3.3].

#### **3.2 Arrangement**

##### **3.2.1**

Planks forming ceiling over the bilges and on the inner bottom are to be easily removable to permit access for maintenance.

##### **3.2.2**

Where the double bottom is intended to carry fuel oil, ceiling on the inner bottom is to be separated from the plating by means of battens 30 mm high, in order to facilitate the drainage of oil leakages to the bilges.

##### **3.2.3**

Where the double bottom is intended to carry water, ceiling on the inner bottom may lie next to the plating, provided a suitable protective composition is applied beforehand.

##### **3.2.4**

The shipyard is to take care that the attachment of ceiling does not affect the tightness of the inner bottom.

#### **3.3 Scantlings**

##### **3.3.1**

The thickness of ceiling boards, when made of pine, is to be not less than 60 mm. Under cargo hatchways, the thickness of ceiling is to be increased by 15 mm.

Where the floor spacing is large, the thicknesses may be considered by the Society on a case by case basis.

## SECTION 6 STRUCTURAL ARRANGEMENT PRINCIPLES

### Symbols

For symbols not defined in this Section, refer to the list defined in Ch 1, Sec 4.

$b_h$  = Breadth, in m, of cargo hatch opening  
 $\ell_b$  = Length, in m, of the free edge of the end bracket.

### 1 Application

The requirements of this section apply to the cargo hold area. For other areas, the requirements of Ch 9, Sec 1 to Ch 9, Sec 4 are to be applied.

### 2 General principles

#### 2.1 Definition

##### 2.1.1 Primary frame spacing

Primary frame spacing, in m, is defined as the distance between the primary supporting members.

##### 2.1.2 Secondary frame spacing

Secondary frame spacing, in m, is defined as the distance between ordinary stiffeners.

#### 2.2 Structural continuity

##### 2.2.1 General

The reduction in scantling from the midship part to the end parts is to be effected as gradually as practicable.

Attention is to be paid to the structural continuity in way of changes in the framing system, at the connections of primary supporting members or ordinary stiffeners and in way of the ends of the fore and aft parts and machinery space and in way of the ends of superstructures.

##### 2.2.2 Longitudinal members

Longitudinal members are to be so arranged as to maintain the continuity of strength.

Longitudinal members contributing to the hull girder longitudinal strength are to extend continuously for a sufficient distance towards the end of ship.

In particular, the continuity of the longitudinal bulkheads, including vertical and horizontal primary supporting members, extended over the cargo hold area is to be ensured beyond the cargo hold area. Scarfing brackets are a possible means.

##### 2.2.3 Primary supporting members

Primary supporting members are to be arranged in such a way that they ensure adequate continuity of strength. Abrupt changes in height or cross section are to be avoided.

##### 2.2.4 Ordinary stiffeners

Ordinary stiffeners contributing to the hull girder longitudinal strength are generally to be continuous when crossing primary supporting members.

##### 2.2.5 Platings

A change in plating thickness in as-built is not to exceed 50% of thicker plate thickness for load carrying direction. The butt weld preparation is to be in accordance with the requirements of Ch 11, Sec 2, [2.2].

## 2.2.6 Stress concentrations

Where stress concentration may occur in way of structural discontinuity, sufficient consideration is to be paid to reduce the stress concentration and adequate compensation and reinforcements are to be provided.

Openings are to be avoided, as far as practicable, in way of highly stressed areas.

Where openings are arranged, the shape of openings is to be such that the stress concentration remains within acceptable limits.

Openings are to be well rounded with smooth edges.

Weld joints are to be properly shifted from places where the stress may highly concentrate.

## 2.3 Connections with higher tensile steel

### 2.3.1 Connections with higher tensile steel

Where steels of different strengths are mixed in a hull structure, due consideration is to be given to the stress in the lower tensile steel adjacent to higher tensile steel.

Where stiffeners of lower tensile steel are supported by primary supporting members of higher tensile steel, due consideration is to be given to the stiffness of primary supporting members and scantlings to avoid excessive stress in the stiffeners due to the deformation of primary supporting members.

Where higher tensile steel is used at deck structures and bottom structure, longitudinal members not contributing to the hull girder longitudinal strength and welded to the strength deck or bottom plating and bilge strake, such as longitudinal hatch coamings, gutter bars, strengthening of deck openings, bilge keel, etc., are to be made of the same higher tensile steel. The same requirement is applicable for non continuous longitudinal stiffeners welded on the web of a primary member contributing to the hull girder longitudinal strength as hatch coamings, stringers and girders.

## 3 Plating

### 3.1 Structural continuity of plating

#### 3.1.1 Insert plate

Where a local increase in plating thickness is generally to be achieved to through insert plates, an insert plate is to be made of the materials of a quality (yield & grade) at least equal to that of the plates on which they are welded.

## 4 Ordinary stiffener

### 4.1 Profile of stiffeners

#### 4.1.1 Stiffener profile with a bulb section

A bulb section may be taken as equivalent to a built-up section. The dimensions of the equivalent angle section are to be obtained, in mm, from the following formulae.

$$h_w = h'_w - \frac{h'_w}{9.2} + 2$$

$$b_f = \alpha \left( t'_w + \frac{h'_w}{6.7} - 2 \right)$$

$$t_f = \frac{h'_w}{9.2} - 2$$

where:

$h'_w, t'_w$  = Height and net thickness of a bulb section, in mm, as shown in Fig 1.

$\alpha$  = Coefficient equal to:

$$\alpha = 1.1 + \frac{(120 - h'_w)^2}{3000} \quad \text{for } h'_w \leq 120$$

$\alpha = 1.0$  for  $h'_w > 120$

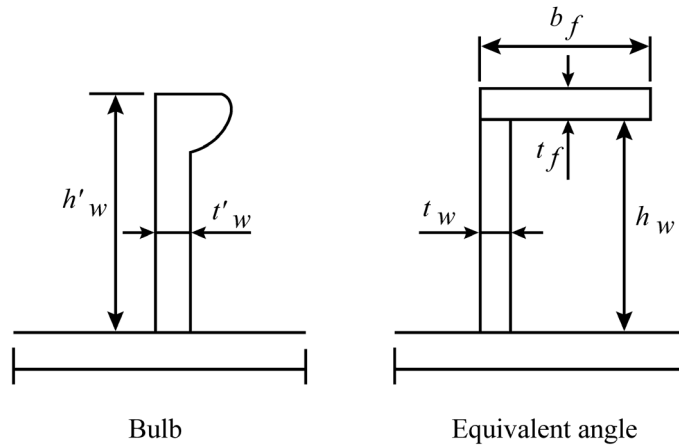
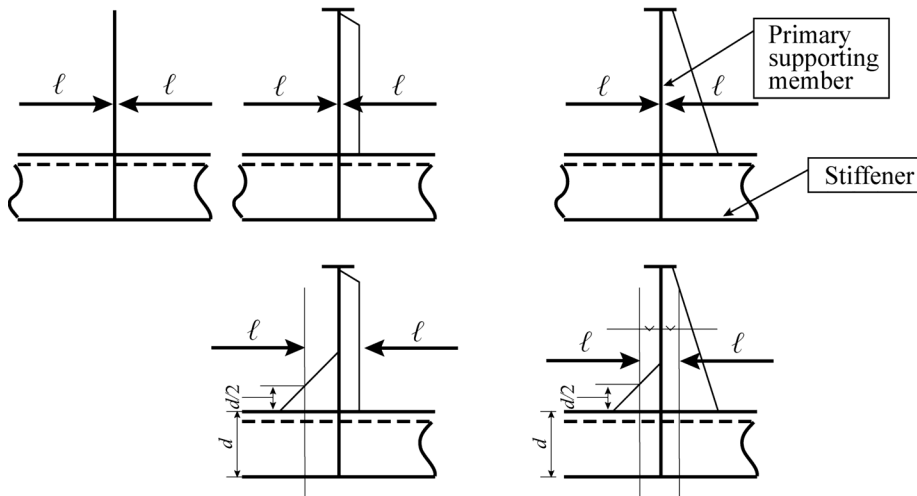

**Fig. 1**  
 Dimensions of stiffeners

## 4.2 Span of ordinary stiffeners

### 4.2.1 Ordinary stiffener

The span  $\ell$  of ordinary stiffeners is to be measured as shown in Fig 2. For curved stiffeners, the span is measured along the chord.



**Fig. 2**  
 Span of ordinary stiffeners

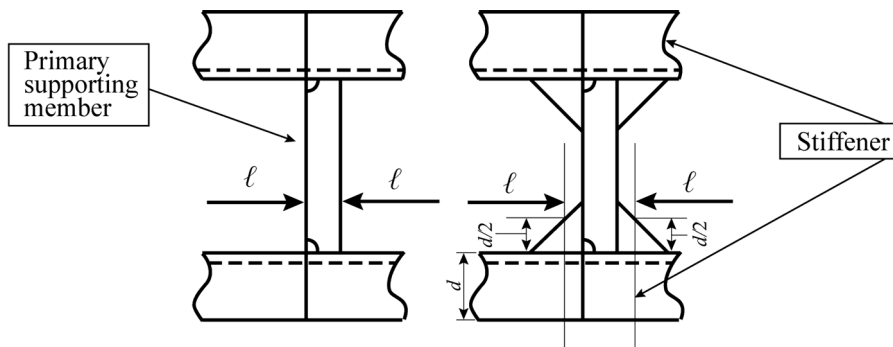

**Fig. 3**  
 Span of ordinary stiffeners within a double hull



#### 4.2.2 Ordinary stiffener within a double hull

The span  $\ell$  of ordinary stiffeners fitted inside a double hull, i.e. when the web of the primary supporting members is connected with the inner hull and the outer shell acting as its flanges, is to be measured as shown in Fig 3.

#### 4.2.3 Ordinary stiffeners supported by struts

The arrangement of ordinary stiffeners supported by struts is not allowed for ships over 120 m in length.

The span  $\ell$  of ordinary stiffeners supported by one strut fitted at mid distance of the primary supporting members is to be taken as  $0.7\ell_2$ .

In case where two struts are fitted between primary supporting members, the span  $\ell$  of ordinary stiffeners is to be taken as the greater of  $1.4\ell_1$  and  $0.7\ell_2$ .

$\ell_1$  and  $\ell_2$  are the spans defined in Figs 4 and 5.

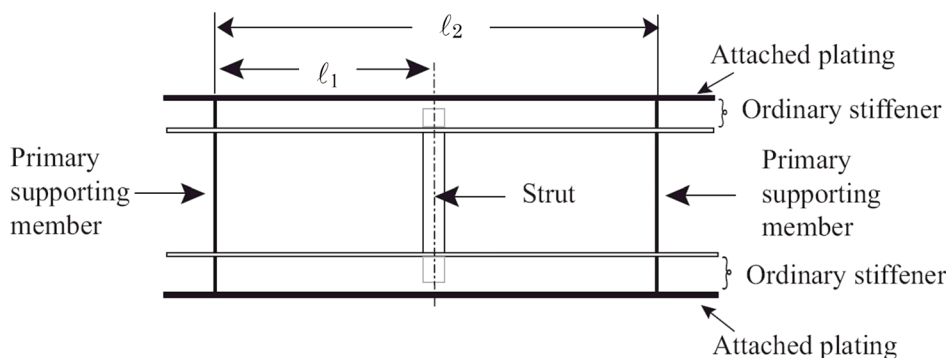

Fig. 4  
Span of ordinary stiffeners with one strut

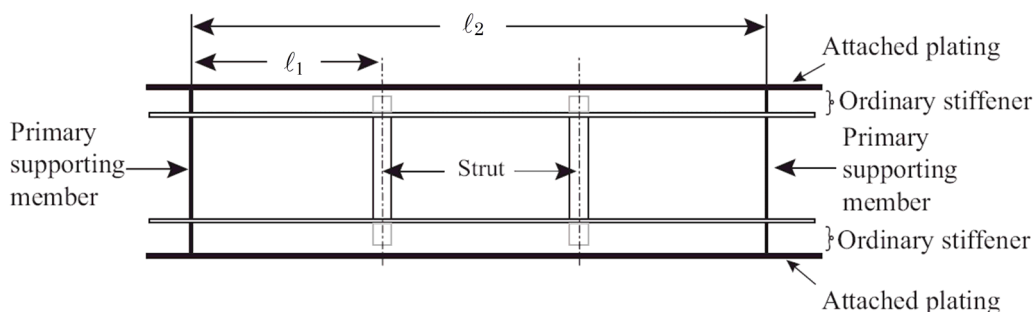

Fig. 5  
Span of ordinary stiffeners with two struts

### 4.3 Attached plating

#### 4.3.1 Effective breadth for yielding check

The effective width  $b_p$  of the attached plating to be considered in the actual net section modulus for the yielding check of ordinary stiffeners is to be obtained, in m, from the following formulae:

— where the plating extends on both sides of the ordinary stiffener:

$$b_p = 0.2\ell, \text{ or}$$

$$b_p = s$$

whichever is lesser.

— where the plating extends on one side of the ordinary stiffener (i.e. ordinary stiffeners bounding openings):

$$b_p = 0.5s$$

$$b_p = 0.1\ell$$

whichever is lesser.

### 4.3.2 Effective width for buckling check

The effective width of the attached plating of ordinary stiffeners for checking the buckling of ordinary stiffeners is defined in Ch 6, Sec 3, [5].

## 4.4 Geometric property of ordinary stiffeners

### 4.4.1 General

Geometric properties of stiffeners such as moment of inertia, section modulus, shear sectional area, slenderness ratio of web plating, etc., are to be calculated based on the net thickness as defined in Ch 3, Sec 2.

### 4.4.2 Stiffener not perpendicular to the attached plating

The actual stiffener's net section modulus is to be calculated about an axis parallel to the attached plating.

Where the stiffener is not perpendicular to the attached plating, the actual net section modulus can be obtained, in  $\text{cm}^3$ , from the following formula:

$$w = w_0 \sin \alpha$$

where:

$w_0$  = Actual net section modulus, in  $\text{cm}^3$ , of the stiffener assumed to be perpendicular to the attached plating

$\alpha$  = Angle, in degrees, between the stiffener web and the attached plating, as shown in Fig 6, but not to be taken less than 50.

The correction is to be applied when  $\alpha$  is between 50 and 75 degrees.

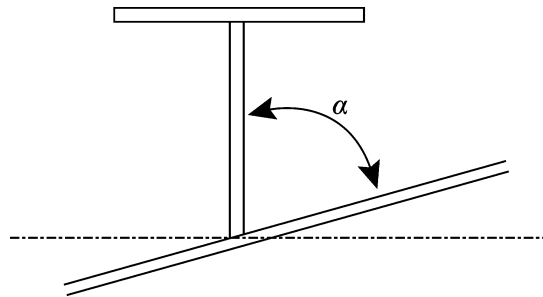

**Fig. 6**  
Angle between stiffener web and attached plating

Where the angle between the web plate of stiffener and the attached plating is less than 50 degrees, tripping bracket is to be fitted at suitable spacing. If the angle between the web plate of an unsymmetrical stiffener and the attached plating is less than 50 degrees, the face plate of the stiffener is to be fitted on the side of open bevel, as shown in Fig 7.

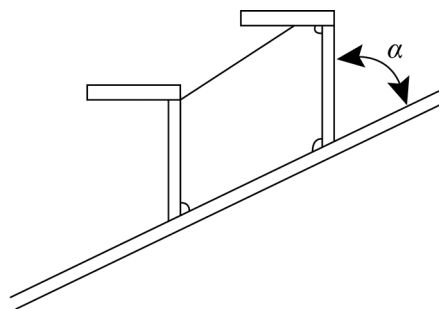
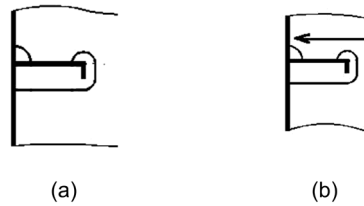

**Fig. 7**  
Orientation of stiffener when the angle is less than 50 degrees

## 4.5 End connections of ordinary stiffeners

### 4.5.1 General

Where ordinary stiffeners are to be continuous through primary supporting members, they are to be properly connected to the web plating so as to ensure proper transmission of loads. Some sample connections are shown in Fig 8 to Fig 11.



**Fig. 8**  
**(a) Connection without collar plate and**  
**(b) Connection with stiffener at side of longitudinal**

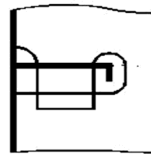

**Fig. 9**  
**Connection with collar plate**

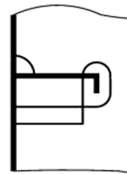

**Fig. 10**  
**Connection with one large collar plate**

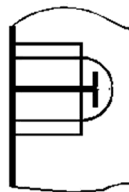

**Fig. 11**  
**Connection with two large collar plates**

#### 4.5.2 Structural continuity of stiffeners

Where ordinary stiffeners are cut at primary supporting members, brackets are to be fitted to ensure structural continuity. In this case, the net section modulus and net sectional area of the brackets are to be not less than those of the ordinary stiffener.

The minimum net thickness of brackets is to be not less than that required for web plate of ordinary stiffeners.

The brackets are to be flanged or stiffened by a welded face plate where:

- the net thickness of the bracket, in mm, is less than  $15\ell_b$ , where  $\ell_b$  is the length, in m, of the free edge of the end bracket or brackets; or
- the longer arm of the bracket is greater than 800 mm.

The net sectional area, in  $\text{cm}^2$ , of the flanged edge or faceplate is to be at least equal to  $10\ell_b$ .

#### 4.5.3 End connections

End connection of stiffeners is to be sufficiently supported by the primary supporting members. Generally, a stiffener or a bracket to support the ordinary stiffener is to be provided.

Where slots for penetration of stiffeners are reinforced with collars, they are to be of the same materials as the primary supporting members.

Brackets or stiffeners to support the ordinary stiffeners are to be of sufficient sectional area and moment of

inertia with respect to structural continuity, and are to have appropriate shape with respect to fatigue strength. If brackets or stiffeners to support the ordinary stiffeners are not fitted, or special slot configurations considering the fatigue strength are provided, fatigue strength assessment for slots are required by the Society.

## **5 Primary supporting members**

### **5.1 General**

#### **5.1.1**

Primary supporting members are to be arranged in such a way that they ensure adequate continuity of strength. Abrupt changes in height or in cross-section are to be avoided.

#### **5.1.2**

Where arrangements of primary supporting members are ensured adequate based on the results of FE analysis, fatigue assessment and ultimate strength assessment, primary supporting members are to be arranged in accordance with the result of such assessment.

### **5.2 Stiffening arrangement**

#### **5.2.1**

Webs of primary supporting members are to be stiffened where the height, in mm, is greater than  $100t$ , where  $t$  is the net web thickness, in mm, of the primary supporting member.

In general, the web stiffeners of primary supporting members are to be spaced not more than  $110t$ .

The net thickness of web stiffeners and brackets are not to be less than the minimum net thickness of the primary members on which they are fitted.

Additional stiffeners are to be fitted in way of end brackets, at the connection with cross ties, etc. of transverse primary supporting members where shearing stress and/or compressive stress is expected to be high. These parts are not to have holes. Cut outs for penetration of ordinary stiffeners in these parts are to be reinforced with collar plates.

Depth of stiffener is to be more than  $1/12$  of stiffener length.

#### **5.2.2**

Tripping brackets (see Fig 12) welded to the face plate are generally to be fitted:

- at every fourth spacing of ordinary stiffeners, without exceeding 4 m.
- at the toe of end brackets
- at rounded face plates
- in way of concentrated loads
- near the change of section.

Where the width of the symmetrical face plate is greater than 400 mm, backing brackets are to be fitted in way of the tripping brackets.

Where the face plate of the primary supporting member exceeds 180 mm on either side of the web, tripping bracket is to support the face plate as well.

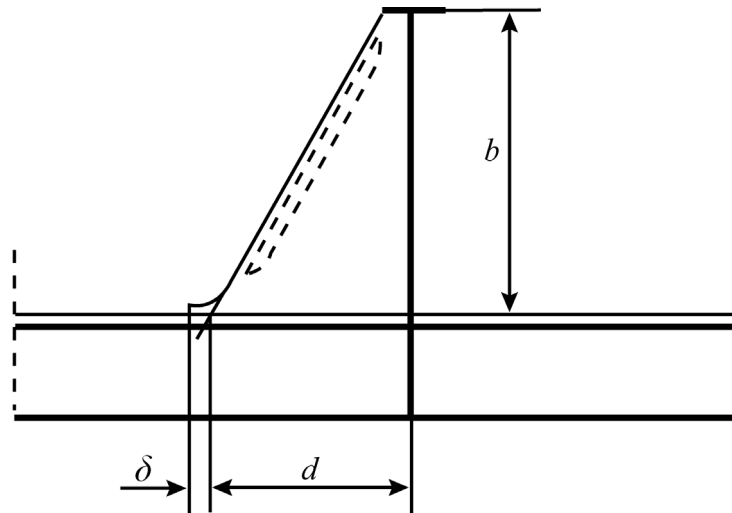

**Fig. 12**  
**Primary supporting member: web stiffener in way of ordinary stiffener**

### 5.2.3

The width of face plate of the primary supporting member except ring shape such as transverse ring in bilge hopper tanks and top side tank is to be not less than one tenth of the depth of the web, where tripping brackets are spaced as specified in [5.2.2].

### 5.2.4

The arm length of tripping brackets is to be not less than the greater of the following values, in m:

$$d = 0.38b$$

$$d = 0.85\sqrt{\frac{s_t}{t}}$$

where:

$b$  = Height, in m, of tripping brackets, shown in Fig 12

$s_t$  = Spacing, in m, of tripping brackets

$t$  = Net thickness, in mm, of tripping brackets.

### 5.2.5

Tripping brackets with a net thickness, in mm, less than  $10\ell_b$  are to be flanged or stiffened by a welded face plate.

The net sectional area, in  $\text{cm}^2$ , of the flanged edge or the face plate is to be not less than  $7\ell_b$ , where  $\ell_b$  is the length, in m, of the free edge of the bracket.

Where the height or breadth of tripping brackets is greater than 3 m, an additional stiffener is to be fitted parallel to the bracket free edge.

## 5.3 Span of primary supporting members

### 5.3.1 Definitions

The span  $\ell$ , in m, of a primary supporting member without end bracket is to be taken as the length of the member between supports.

The span  $\ell$ , in m, of a primary supporting member with end brackets is taken between points where the depth of the bracket is equal to half the depth of the primary supporting member as shown in Fig 13(a).

However, in case of curved brackets where the face plate of the member is continuous along the face of the bracket, as shown in Fig 13(b), the span is taken between points where the depth of the bracket is equal to one quarter the depth of the primary supporting member.

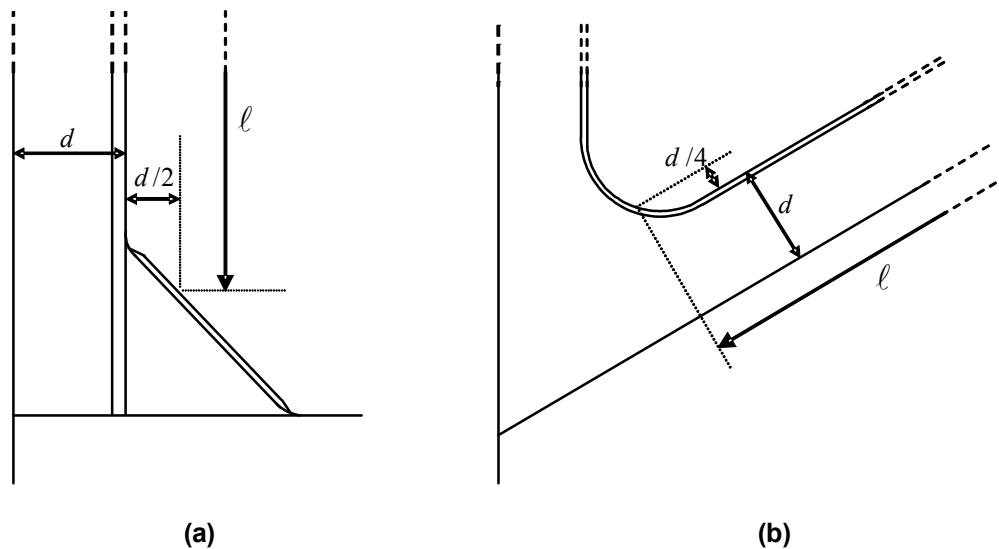

**Fig. 13**  
Span of primary support member

## 5.4 Effective breadth of primary supporting member

### 5.4.1 General

The effective breadth of the attached plating of a primary supporting member to be considered in the actual net section modulus for the yielding check is to be taken as the mean spacing between adjacent primary supporting members.

## 5.5 Geometric properties

### 5.5.1 General

Geometric properties of primary supporting members such as moment of inertia, section modulus, shear sectional area, slenderness ratio of web plating, etc., are to be calculated based on the net thickness as specified in Ch 3, Sec 2.

## 5.6 Bracketed end connection

### 5.6.1 General

Where the ends of the primary supporting members are connected to bulkheads, inner bottom, etc., the end connections of all primary supporting members are to be balanced by effective supporting members on the opposite side of bulkheads, inner bottoms, etc..

Tripping brackets are to be provided on the web plate of the primary supporting members at the inner edge of end brackets and connection parts of the other primary supporting members and also at the proper intervals to support the primary supporting members effectively.

### 5.6.2 Dimensions of brackets

Arm length of bracket is generally not to be less than one-eighth of span length of the primary member, unless otherwise specified. Arm lengths of brackets at both ends are to be equal, as far as practicable.

The height of end brackets is to be not less than that of the primary supporting member. The net thickness of the end bracket web is not to be less than that of the web plate of the primary supporting member.

The scantlings of end brackets are to be such that the section modulus of the primary supporting member with end brackets is not less than that of the primary supporting member at mid-span point.

The width, in mm, of the face plate of end brackets is to be not less than  $50(\ell_b+1)$ .

Moreover, the net thickness of the face plate is to be not less than that of the bracket web.

Stiffening of end brackets is to be designed such that it provides adequate buckling web stability.

The following prescriptions are to be applied:

— where the length  $\ell_b$  is greater than 1.5 m, the web of the bracket is to be stiffened

- the net sectional area, in  $\text{cm}^2$ , of web stiffeners is to be not less than  $16.5\ell$ , where  $\ell$  is the span, in m, of the stiffener
- tripping flat bars are to be fitted to prevent lateral buckling of web stiffeners. Where the width of the symmetrical face plate is greater than 400 mm, additional backing brackets are to be fitted.

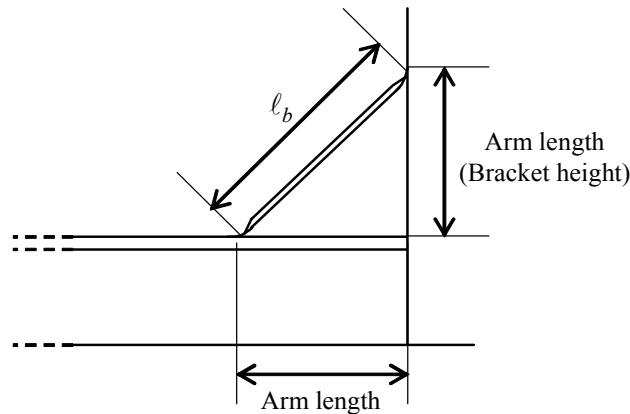

**Fig. 14**  
**Dimension of brackets**

## 5.7 Cut-outs and holes

### 5.7.1

Cut-outs for the passage of ordinary stiffeners are to be as small as possible and well rounded with smooth edges.

The depth of cut-outs is to be not greater than 50% of the depth of the primary supporting member.

### 5.7.2

Where openings such as lightening holes are cut in primary supporting members, they are to be equidistant from the face plate and corners of cut-outs and, in general, their height is to be not greater than 20% of the web height.

Where lightening holes with free edges are provided, the dimensions and locations of lightening holes are generally to be as shown in Fig 15.

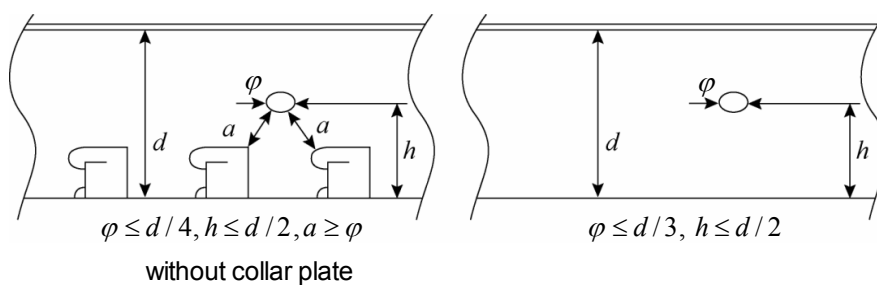

**Fig. 15**  
**Location and dimensions of lightening holes**

Where lightening holes are cut in the brackets, the distance from the circumference of the hole to the free flange of brackets is not to be less than the diameter of the lightening hole.

### 5.7.3

Openings are not to be fitted in way of toes of end brackets.

### 5.7.4

At the mid-part within 0.5 times of the span of primary supporting members, the length of openings is to be not greater than the distance between adjacent openings.

At the ends of the span, the length of openings is to be not greater than 25% of the distance between adjacent

openings.

### 5.7.5

In the case of large openings in the web of primary supporting members (e.g. where a pipe tunnel is fitted in the double bottom), the secondary stresses in primary supporting members are to be considered for the reinforcement of the openings.

This may be carried out by assigning an equivalent net shear sectional area to the primary supporting member obtained, in cm<sup>2</sup>, according from the following formula:

$$A_{sh} = \frac{A_{sh1}}{1 + \frac{0.0032\ell^2 A_{sh1}}{I_1}} + \frac{A_{sh2}}{1 + \frac{0.0032\ell^2 A_{sh2}}{I_2}}$$

where (see Fig 16):

- $I_1, I_2$  = Net moments of inertia, in cm<sup>4</sup>, of deep webs (1) and (2), respectively, with attached plating around their neutral axes parallel to the plating  
 $A_{sh1}, A_{sh2}$  = Net shear sectional areas, in cm<sup>2</sup>, of deep webs (1) and (2), respectively, taking account of the web height reduction by the depth of the cut out for the passage of the ordinary stiffeners, if any  
 $\ell$  = Span, in cm, of deep webs (1) and (2).

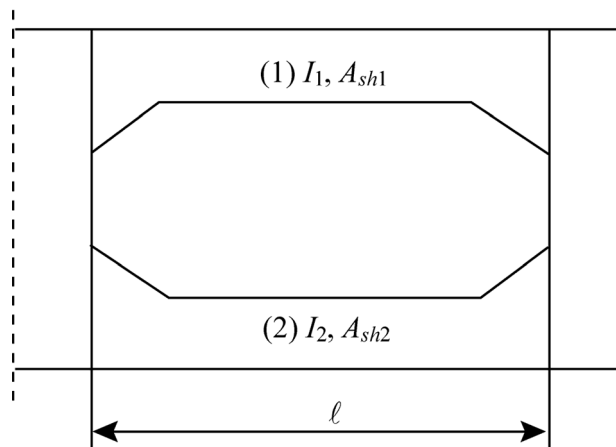

**Fig. 16**  
Large openings in the web of primary supporting members

## 6 Double bottom

### 6.1 General

#### 6.1.1 Double bottom extend

Ref. SOLAS Ch. II-1, Part B, Reg. 12-1

*A double bottom is to be fitted extending from the collision bulkhead to the afterpeak bulkhead.*

#### 6.1.2 Framing system

For ships greater than 120 m in length, the bottom, the double bottom and the sloped bulkheads of hopper tanks are to be of longitudinal system of frame arrangement at least within the cargo hold area. The spacing of the floors and bottom girders is not only governed by frame spaces but requirement in absolute value, in metres, is also indicated in [6.3.3] and [6.4.1].

#### 6.1.3 Height of double bottom

Unless otherwise specified, the height of double bottom is not to be less than  $B/20$  or 2 m whichever is the lesser.

Where the height of the double bottom varies, the variation is generally to be made gradually and over an adequate length; the knuckles of inner bottom plating are to be located in way of plate floors.

Where this is impossible, suitable longitudinal structures such as partial girders, longitudinal brackets etc., fitted across the knuckle are to be arranged.



### 6.1.4 Dimensions of double bottom

The breadth of double bottom is taken as shown in Fig 17.

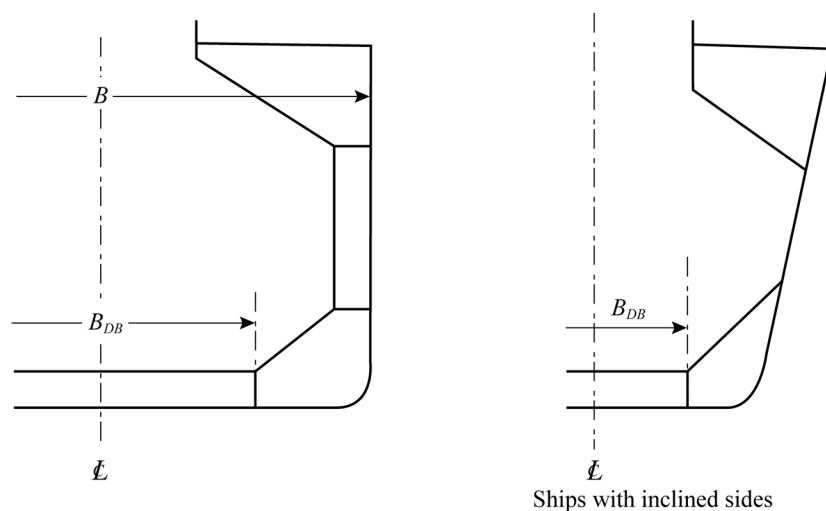

**Fig. 17**  
**Breadth of double bottom**

### 6.1.5 Docking

The bottom is to have sufficient strength to withstand the loads resulting from the dry-docking of the ship.

Where docking brackets are provided between solid floors and connecting the centreline girder to the bottom shell plating, the docking brackets are to be connected to the adjacent bottom longitudinals.

### 6.1.6 Continuity of strength

Where the framing system changes from longitudinal to transverse, special attention is to be paid to the continuity of strength by means of additional girders or floors. Where this variation occurs within  $0.6L$  amidships, the inner bottom is generally to be maintained continuous by means of inclined plating.

Bottom and inner bottom longitudinal ordinary stiffeners are generally to be continuous through the floors.

The actual net thickness and the yield stress of the lower strake of the sloped bulkhead of hopper tanks, if any, are not to be less than these ones of the inner bottom with which the connection is made.

### 6.1.7 Reinforcement

The bottom is to be locally stiffened where concentrated loads are envisaged such as under the main engine and thrust seat.

Girders and floors are to be fitted under each line of pillars, toes of end brackets of bulkhead stiffeners and slant plate of lower stool of bulkhead. In case girders and floors are not fitted, suitable reinforcement is to be provided by means of additional primary supporting members or supporting brackets.

When solid ballast is fitted, it is to be securely positioned. If necessary, intermediate floors may be required for this purpose.

### 6.1.8 Manholes and lightening holes

Manholes and lightening holes are to be provided in floors and girders to ensure accessibility and ventilation as a rule.

The number of manholes in tank tops is to be kept to the minimum compatible with securing free ventilation and ready access to all parts of the double bottom.

Manholes may not be cut in the girders and floors below the heels of pillars.

### 6.1.9 Air holes and drain holes

Air and drain holes are to be provided in floors and girders.

Air holes are to be cut as near to the inner bottom and draining holes as near to the bottom shell as practicable.

Air holes and drain holes are to be designed to aid full ballast water and sediment removal to allow for effective ballast water exchange.

### **6.1.10 Drainage of tank top**

Effective arrangements are to be provided for draining water from the tank top. Where wells are provided for the drainage, such wells are not to extend for more than one-half depth of the height of double bottom.

### **6.1.11 Striking plate**

Striking plates of adequate thickness or other equivalent arrangements are to be provided under sounding pipes to prevent the sounding rod from damaging the bottom plating.

### **6.1.12 Duct keel**

Where a duct keel is arranged, the centre girder may be replaced by two girders generally spaced, no more than 3 m apart.

The structures in way of the floors are to ensure sufficient continuity of the latter.

## **6.2 Keel**

### **6.2.1**

The width of the keel is to be not less than the value obtained, in m, from the following formula:

$$b = 0.8 + L / 200$$

## **6.3 Girders**

### **6.3.1 Centre girder**

The centre girder is to extend within the cargo hold area and is to extend forward and aft as far as practicable, and structural continuity thereof to be continuous within the full length of the ship.

Where double bottom compartments are used for the carriage of fuel oil, fresh water or ballast water, the centre girder is to be watertight, except for the case such as narrow tanks at the end parts or when other watertight girders are provided within  $0.25B$  from the centreline, etc.

### **6.3.2 Side girders**

The side girders are to extend within the parallel part of cargo hold area and are to extend forward and aft of cargo hold area as far as practicable.

### **6.3.3 Spacing**

The spacing of adjacent girders is generally to be not greater than 4.6 m or 5 times the spacing of bottom or inner bottom ordinary stiffeners, whichever is the smaller. Greater spacing may be accepted depending on the result of the analysis carried out according to Ch 7.

## **6.4 Floors**

### **6.4.1 Spacing**

The spacing of floors is generally to be not greater than 3.5 m or 4 frame spaces as specified by the designer, whichever is the smaller. Greater spacing may be accepted depending on the result of the analysis carried out according to Ch 7.

### **6.4.2 Floors in way of transverse bulkheads**

Where transverse bulkhead is provided with lower stool, solid floors are to be fitted in line with both sides of lower stool. Where transverse bulkhead is not provided with lower stool, solid floors are to be fitted in line with both flanges of the vertically corrugated transverse bulkhead or in line of plane transverse bulkhead.

### **6.4.3 Web stiffeners**

Floors are to be provided with web stiffeners in way of longitudinal ordinary stiffeners. Where the web stiffeners are not provided, fatigue strength assessment for the cut out and connection of longitudinal stiffener is to be carried out.

## **6.5 Bilge strake and bilge keel**

### **6.5.1 Bilge strake**

Where some of the longitudinal stiffeners at the bilge part are omitted, longitudinal stiffeners are to be provided

as near to the turns of bilge as practicable.

### 6.5.2 Bilge keel

Bilge keels are not to be welded directly to the shell plating. An intermediate flat is required on the shell plating. The ends of the bilge keel are to be sniped as shown in Fig.18 or rounded with large radius. The ends are to be located in way of transverse bilge stiffeners inside the shell plating and the ends of intermediate flat are not to be located at the block joints.

The bilge keel and the intermediate flat are to be made of steel with the same yield stress as the one of the bilge strake. The bilge keel with a length greater than  $0.15L$  is to be made with the same grade of steel as the one of bilge strake.

The net thickness of the intermediate flat is to be equal to that of the bilge strake. However, this thickness may generally not be greater than 15 mm.

Scallops in the bilge keels are to be avoided.

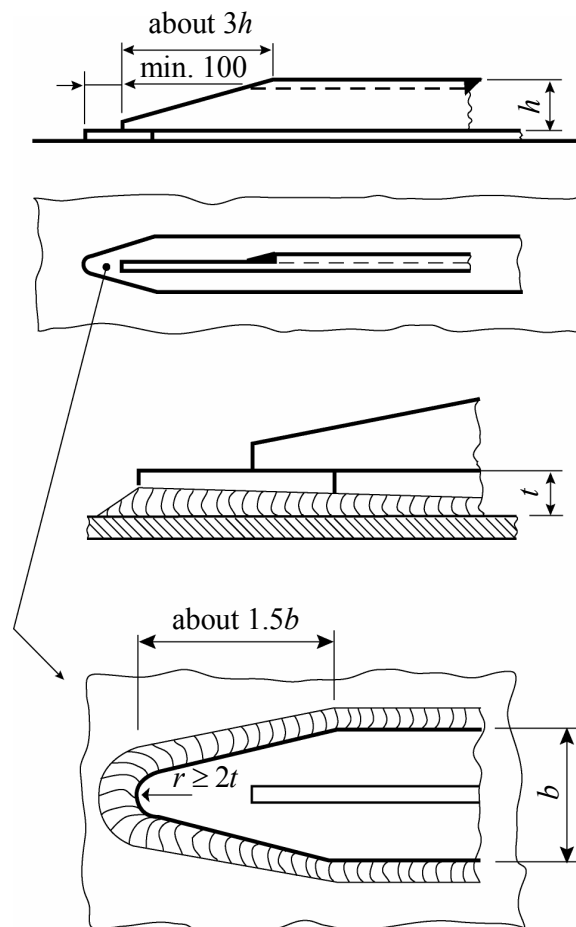

**Fig. 18**  
Example of bilge keel arrangement

## 7 Double Side structure

### 7.1 Application

#### 7.1.1

The requirement of this article applies to longitudinally or transversely framed side structure.

The transversely framed side structures are built with transverse frames possibly supported by horizontal side girders.

The longitudinally framed side structures are built with longitudinal ordinary stiffeners supported by vertical primary supporting members.

The side within the hopper and topside tanks is, in general, to be longitudinally framed. It may be transversely framed when this is accepted for the double bottom and the deck according to [6.1.2] and [9.1.1], respectively.

## **7.2 Design principles**

### **7.2.1**

Where the double side space is void, the structural members bounding this space are to be structurally designed as a water ballast tank according to Ch 6. In such case the corresponding air pipe is considered as extending 0.76 m above the freeboard deck at side.

For corrosion addition, the space is still considered as void space.

## **7.3 Structural arrangement**

### **7.3.1 General**

Double side structures are to be thoroughly stiffened by providing web frames and side stringers within the double hull.

Continuity of the inner side structures, including stringers, is to be ensured within and beyond the cargo area. Scarfing brackets are a possible means.

### **7.3.2 Primary supporting member spacing**

For transverse framing system, the spacing of transverse side primary supporting members is, in general, to be not greater than 3 frame spaces.

Greater spacing may be accepted depending on the results of the analysis carried out according to Ch 7 for the primary supporting members in the cargo holds.

The vertical distance between horizontal primary members of the double side is not to exceed 6 m, unless the appropriate structural members complying with the requirements for safe access are provided.

### **7.3.3 Primary supporting member fitting**

Transverse side primary supporting members are to be fitted in line with web frames in topside and hopper tanks. However where it is not practicable for top side web frames, large brackets are to be fitted in the topside space in line with double side web frames.

Transverse bulkheads in double side space are to be arranged in line with the cargo hold transverse bulkheads.

Vertical primary supporting members are to be fitted in way of hatch end beams.

Unless otherwise specified, horizontal side girders are to be fitted aft of the collision bulkhead up to 0.2L aft of the fore end, in line with fore peak girders.

### **7.3.4 Transverse ordinary stiffeners**

The transverse ordinary stiffeners of the shell and the inner side are to be continuous or fitted with bracket end connections within the height of the double side. The transverse ordinary stiffeners are to be effectively connected to stringers. At their upper and lower ends, opposing shell and inner side transverse ordinary stiffeners and supporting stringer plates are to be connected by brackets.

### **7.3.5 Longitudinal ordinary stiffeners**

The longitudinal side shell and inner side ordinary stiffeners, where fitted, are to be continuous within the length of the parallel part of cargo hold area and are to be fitted with brackets in way of transverse bulkheads aligned with cargo hold bulkheads. They are to be effectively connected to transverse web frames of the double side structure. For the side longitudinal and ordinary stiffeners of inner skin out of parallel part of cargo hold area, special attention is to be paid for a structural continuity.

### **7.3.6 Sheer strake**

The width of the sheer strake is to be not less than the value obtained, in m, from the following formula:

$$b = 0.715 + 0.425L / 100$$

The sheer strake may be either welded to the stringer plate or rounded.

If the sheer strake is rounded, its radius, in mm, is to be not less than  $17t_s$ , where  $t_s$  is the net thickness, in mm, of the sheer strake.

The fillet weld at the connection of the welded sheer strake and deck plate may be either full penetration or deep penetration weld.

The upper edge of the welded sheer strake is to be rounded smooth and free of notches. Fixtures such as bulwarks, eye plates are not to be directly welded on the upper edge of sheer strake, except in fore and aft parts.

Longitudinal seam welds of rounded sheer strake are to be located outside the bent area at a distance not less than 5 times the maximum net thicknesses of the sheer strake.

The transition from a rounded sheer strake to an angled sheer strake associated with the arrangement of superstructures at the ends of the ship is to be carefully designed so as to avoid any discontinuities.

### **7.3.7 Plating connection**

At the locations where the inner hull plating and the inner bottom plating are connected, attention is to be paid to the structural arrangement so as not to cause stress concentration.

Knuckles of the inner side are to be adequately stiffened by ordinary stiffeners or equivalent means, fitted in line with the knuckle.

The connections of hopper tank plating with inner hull and with inner bottom are to be supported by a primary supporting member.

## **7.4 Longitudinally framed double side**

### **7.4.1 General**

Adequate continuity of strength is to be ensured in way of breaks or changes in the width of the double side.

## **7.5 Transversely framed double side**

### **7.5.1 General**

Transverse frames of side and inner side may be connected by means of struts. Struts are generally to be connected to transverse frames by means of vertical brackets.

## **8 Single side structure**

### **8.1 Application**

#### **8.1.1**

This article applies to the single side structure with transverse framing.

If single side structure is supported by transverse or longitudinal primary supporting members, the requirements in [7] above apply to these primary supporting members as regarded to ones in double side skin.

### **8.2 General arrangement**

#### **8.2.1**

Side frames are to be arranged at every frame space.

If air pipes are passing through the cargo hold, they are to be protected by appropriate measures to avoid a mechanical damage.

### **8.3 Side frames**

#### **8.3.1 General**

Frames are to be built-up symmetrical sections with integral upper and lower brackets and are to be arranged with soft toes.

The side frame flange is to be curved (not knuckled) at the connection with the end brackets. The radius of curvature is not to be less than  $r$ , in mm, given by:

$$r = \frac{0.4b_f^2}{t_f + t_C}$$

where:

$t_C$  = Corrosion addition, in mm, specified in Ch 3, Sec 3  
 $b_f$  and  $t_f$  = Flange width and net thickness of the curved flange, in mm. The end of the flange is to be sniped.  
 In ships less than 190 m in length, mild steel frames may be asymmetric and fitted with separate brackets. The face plate or flange of the bracket is to be sniped at both ends. Brackets are to be arranged with soft toes.  
 The dimensions of side frames are defined in Fig 19.

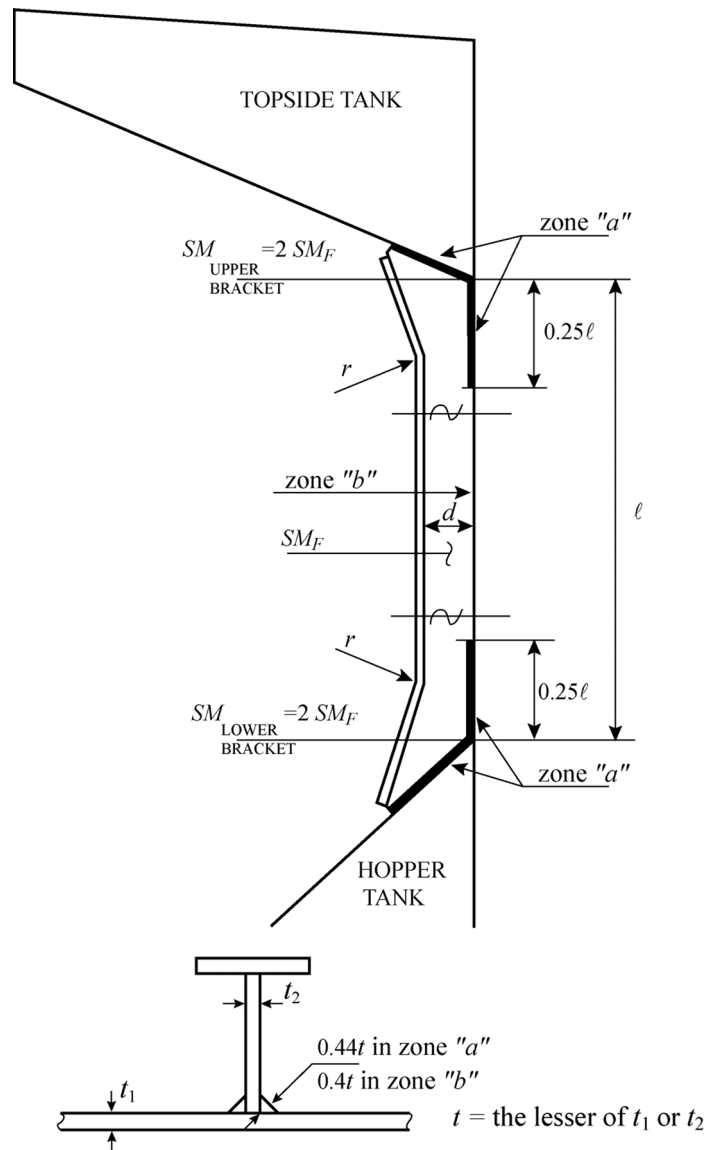

Fig. 19  
 Dimensions of side frames

## 8.4 Upper and lower brackets

### 8.4.1

The face plates or flange of the brackets is to be sniped at both ends.

Brackets are to be arranged with soft toes.

The as-built thickness of the brackets is to be not less than the as-built thickness of the side frame webs to which they are connected.

### 8.4.2

The dimensions (in particular the height and length) of the lower brackets and upper brackets are to be not less than those shown in Fig 20.

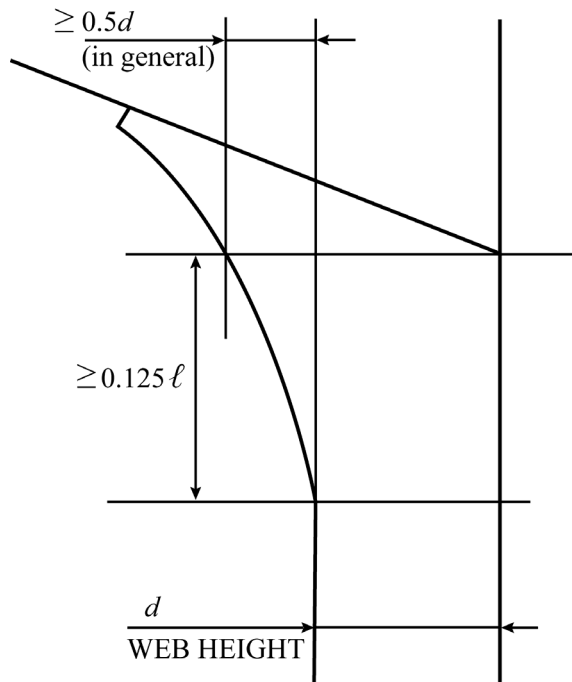

**Fig. 20**  
Dimensions of lower and upper brackets

## 8.5 Tripping brackets

### 8.5.1

In way of the foremost hold and in the holds of **BC-A** ships, side frames of asymmetrical section are to be fitted with tripping brackets at every two frames, as shown in Fig 21.

The as-built thickness of the tripping brackets is to be not less than the as-built thickness of the side frame webs to which they are connected.

Double continuous welding is to be adopted for the connections of tripping brackets with side shell frames and plating.

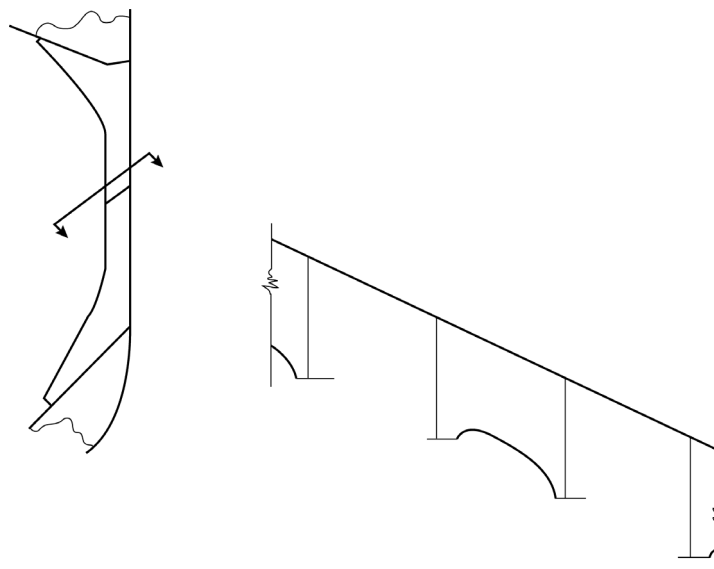
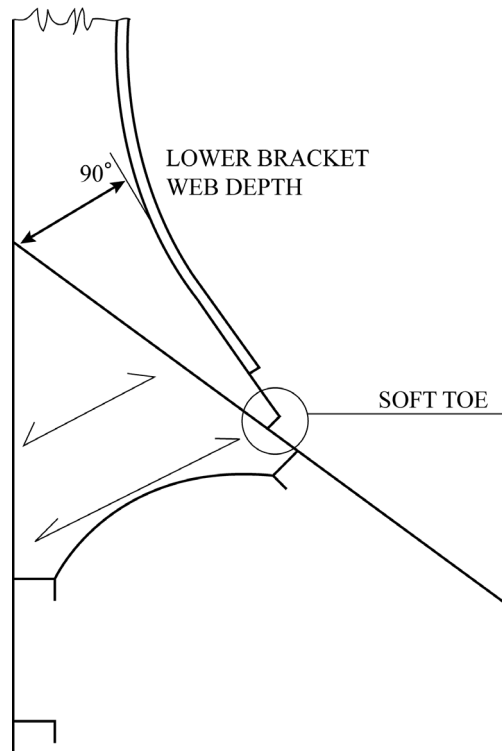

**Fig. 21**  
Tripping brackets to be fitted in way of foremost hold

## 8.6 Support structure

### 8.6.1

Structural continuity with the lower and upper end connections of side frames is to be ensured within hopper and topside tanks by connecting brackets as shown in Fig 22. The brackets are to be stiffened against buckling according to [5.6.2].



**Fig. 22**  
Example of support structure for lower end

## 9 Deck structure

### 9.1 Application

#### 9.1.1

The deck outside the line of hatches and the topside tank sloping plates are to be longitudinally framed. Within the line of hatches, other arrangement than longitudinal framing may be considered provided that adequate structural continuity is ensured.

### 9.2 General arrangement

#### 9.2.1

The spacing of web frames in topside tanks is generally to be not greater than 6 frame spaces.

Greater spacing may be accepted by the Society, on a case-by-case basis, depending on the results of the analysis carried out according to Ch 7.

#### 9.2.2

The deck supporting structure is to be made of ordinary stiffeners longitudinally or transversely arranged, supported by primary supporting members.

#### 9.2.3 Deck between hatches

Inside the line of openings, a transverse structure is to be generally adopted for the cross deck structures, beams are to be adequately supported by girders and extended up to the second longitudinal from the hatch side girders towards the bulwark. Where this is impracticable, intercostal stiffeners are to be fitted between the hatch side girder and the second longitudinal.



Smooth connection of the strength deck at side with the deck between hatches is to be ensured by a plate of intermediate thickness.

#### **9.2.4 Topside tank structures**

Topside tank structures are to extend as far as possible within the machinery space and are to be adequately tapered.

Where a double side primary supporting member is fitted outside the plane of the topside tank web frame, a large bracket is to be fitted in line with.

#### **9.2.5 Stringer plate**

The width of the stringer plate is to be not less than the value obtained, in m, from the following formula:

$$b = 0.35 + 0.5L / 100$$

Rounded stringer plate, where adopted, are to have a radius complying with the requirements in [7.3.6].

#### **9.2.6**

Adequate continuity of strength by providing proper overlapping of structures and adequate scarphing members is to be ensured in way of:

- stepped strength deck
- changes in the framing system.

#### **9.2.7**

Deck supporting structures under deck machinery, cranes, king post and equipment such as towing equipment, mooring equipment, etc., are to be adequately stiffened.

#### **9.2.8**

Pillars or other supporting structures are to be generally fitted under heavy concentrated loads.

#### **9.2.9**

A suitable stiffening arrangement is considered in way of the ends and corners of deckhouses and partial superstructures.

#### **9.2.10 Connection of hatch end beams with deck structures**

The connection of hatch end beams with deck structures is to be properly ensured by fitting inside the topside tanks additional web frames or brackets.

#### **9.2.11 Construction of deck plating**

Hatchways or other openings on decks are to have rounded corners, and compensation is to be suitably provided.

### **9.3 Longitudinally framed deck**

#### **9.3.1 General**

Deck longitudinals within the parallel part of cargo hold area except within the line of hatch openings are to be continuous in way of deck transverses and transverse bulkheads. For the deck longitudinals out of parallel part of cargo hold area, other arrangements may be considered, provided adequate continuity of longitudinal strength is ensured.

Connections at ends of longitudinal stiffeners are to ensure a sufficient strength to bending and shear.

### **9.4 Transversely framed deck**

#### **9.4.1 General**

Where the deck structure is transversely framed, deck beams or deck transverse stiffeners are to be fitted at each frame.

Transverse beams or deck transverse stiffeners are to be connected to side structure or frames by brackets.

## 9.5 Hatch supporting structures

### 9.5.1

Hatch side girders and hatch end beams of reinforced scantlings are to be fitted in way of cargo hold openings.

### 9.5.2

The connection of hatch end beams to web frames is to be ensured. Hatch end beams are to be aligned with transverse web frames in topside tanks.

### 9.5.3

Clear of openings, adequate continuity of strength of longitudinal hatch coamings is to be ensured by under deck girders.

At hatchway corners, deck girders or their extension parts provided under deck in line with hatch coamings and hatch end beams are to be effectively connected so as to maintain the continuity in strength.

### 9.5.4

For ships with holds designed for loading/discharging by grabs and having the additional class notation **GRAB[X]**, wire rope grooving in way of cargo holds openings is to be prevented by fitting suitable protection such as half-round bar on the hatch side girders (i.e. upper portion of top side tank plates)/hatch end beams in cargo hold and upper portion of hatch coamings.

## 9.6 Openings in the strength deck

### 9.6.1 General

Openings in the strength deck are to be kept to a minimum and spaced as far as practicable from one another and from the breaks of effective superstructures. Openings are to be cut as far as practicable from hatchway corners, hatch side coamings and side shell platings.

### 9.6.2 Small opening location

Openings are generally to be cut outside the limits as shown in Fig 23 in dashed area, defined by:

- the bent area of a rounded sheer strake, if any, or the side shell
- $e = 0.25(B - b)$  from the edge of opening
- $c = 0.07\ell + 0.1b$  or  $0.25b$ , whichever is greater

where:

- $b$  = Width, in m, of the hatchway considered, measured in the transverse direction. (see Fig 23)
- $\ell$  = Width, in m, in way of the corner considered, of the cross deck strip between two consecutive hatchways, measured in the longitudinal direction. (see Fig 23).

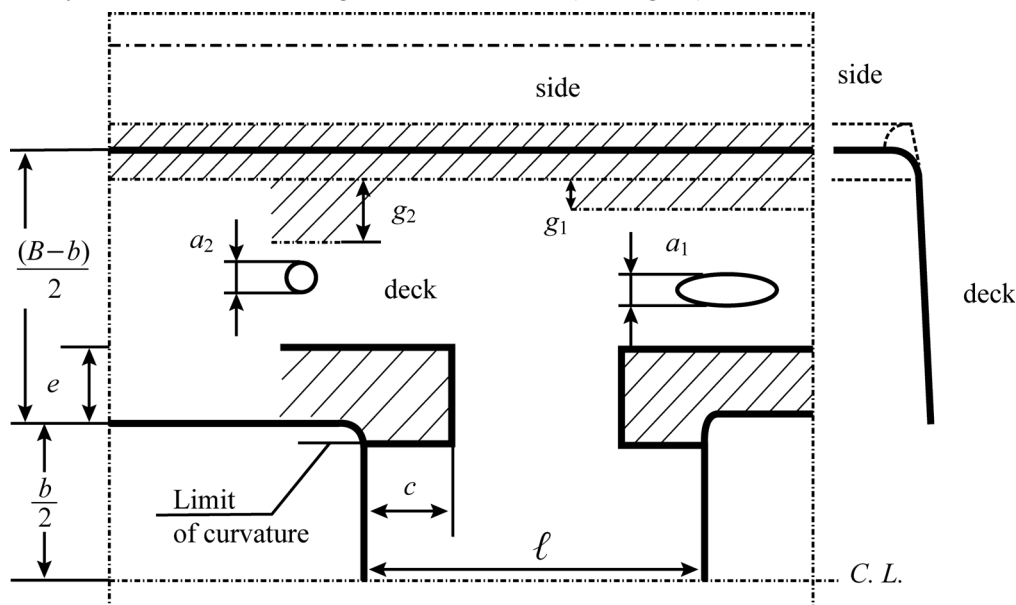
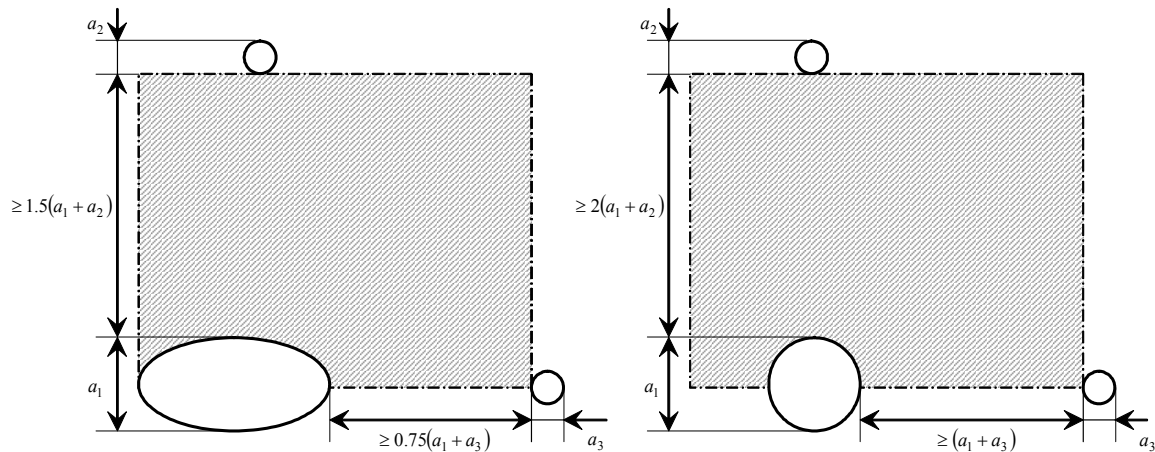

Fig. 23  
Position of openings in strength deck



**Fig. 24**  
**Elliptical and circular openings in strength deck**

Moreover the transverse distance between these limits and openings or between openings together is not to be less than the followings:

- Transverse distance between the above limits and openings or between hatchways and openings as shown in Fig 23:
  - $g_2 = 2a_2$  for circular openings
  - $g_1 = a_1$  for elliptical openings
- Transverse distance between openings as shown in Fig 24:
  - $2(a_1 + a_2)$  for circular openings
  - $1.5(a_1 + a_2)$  for elliptical openings

where

- $a_1$  = Transverse dimension of elliptical openings, or diameter of circular openings, as the case may be
- $a_2$  = Transverse dimension of elliptical openings, or diameter of circular openings, as the case may be
- $a_3$  = Longitudinal dimension of elliptical openings, or diameter of circular openings, as the case may be

- Longitudinal distance between openings is not to be less than the followings:
  - $(a_1 + a_3)$  for circular openings
  - $0.75(a_1 + a_3)$  for elliptical openings and for an elliptical opening in line with a circular one.

If the opening arrangements do not comply with these requirements, the longitudinal strength assessment in accordance with Ch 5 is to be carried out by subtracting such opening areas.

### 9.6.3 Corner of hatchways

For hatchways located within the cargo area, insert plates, whose thickness is to be determined according to the formula given after, are generally to be fitted in way of corners where the plating cut-out has a circular profile. The radius of circular corners is to be not less than 5% of the hatch width, where a continuous longitudinal deck girder is fitted below the hatch coaming.

Corner radius, in the case of the arrangement of two or more hatchways athwartship, is considered by the Society on a case by case basis.

For hatchways located within the cargo area, insert plates are, in general, not required in way of corners where the plating cut-out has an elliptical or parabolic profile and the half axes of elliptical openings, or the half lengths of the parabolic arch, are not less than:

- 1/20 of the hatchway width or 600 mm, whichever is the lesser, in the transverse direction
- twice the transverse dimension, in the fore and aft direction.

Where insert plates are required, their net thickness is to be obtained, in mm, from the following formula:

$$t_{INS} = (0.8 + 0.4\ell / b)t$$

without being taken less than  $t$  or greater than  $1.6t$

where:

- $\ell$  = Width, in m, in way of the corner considered, of the cross deck strip between two consecutive hatchways, measured in the longitudinal direction (see Fig 23)
- $b$  = Width, in m, of the hatchway considered, measured in the transverse direction (see Fig 23)
- $t$  = Actual net thickness, in mm, of the deck at the side of the hatchways.

For the extreme corners of end hatchways, the thickness of insert plates is to be 60% greater than the actual thickness of the adjacent deck plating. A lower thickness may be accepted by the Society on the basis of calculations showing that stresses at hatch corners are lower than permissible values.

Where insert plates are required, the arrangement is shown in Fig 25, in which  $d_1$ ,  $d_2$ ,  $d_3$  and  $d_4$  are to be greater than the ordinary stiffener spacing.

For hatchways located outside the cargo area, a reduction in the thickness of the insert plates in way of corners may be considered by the Society on a case by case basis.

For ships having length  $L$  of 150 m or above, the corner radius, the thickness and the extent of insert plate may be determined by the results of a direct strength assessment according to Ch 7, Sec 2 and Sec 3, including buckling check and fatigue strength assessment of hatch corners according to Ch 8, Sec 5.

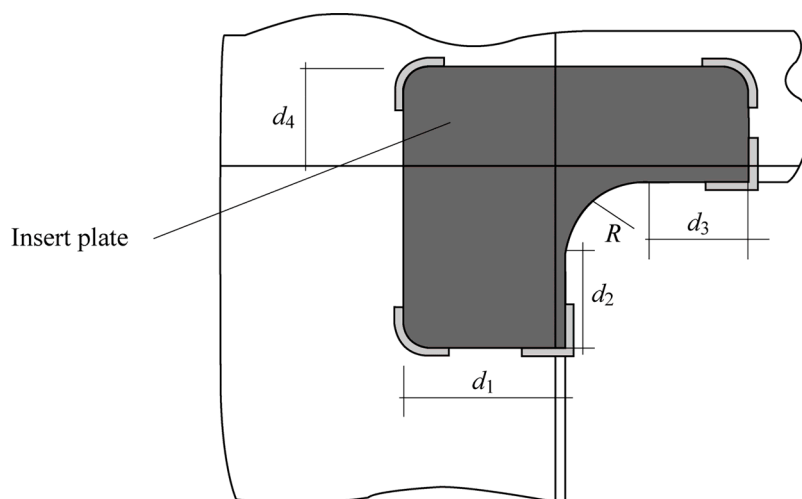

Fig. 25  
Hatch corner insert plate

## 10 Bulkhead structure

### 10.1 Application

#### 10.1.1

The requirements of this article apply to longitudinal and transverse bulkhead structures which may be plane or corrugated.

#### 10.1.2 Plane bulkheads

Plane bulkheads may be horizontally or vertically stiffened.

Horizontally framed bulkheads are made of horizontal ordinary stiffeners supported by vertical primary supporting members.

Vertically framed bulkheads are made of vertical ordinary stiffeners which may be supported by horizontal girders.

### 10.2 General

#### 10.2.1

The web height of vertical primary supporting members of bulkheads may be gradually tapered from bottom to deck.

## 10.2.2

The net thickness of the after peak bulkhead plating in way of the stern tube is to be increased by at least 60% of other part of after peak bulkhead plating.

## 10.3 Plane bulkheads

### 10.3.1 General

Where a bulkhead does not extend up to the uppermost continuous deck, suitable strengthening is to be provided in the extension of the bulkhead.

Bulkheads are to be stiffened in way of the deck girders.

The bulkhead stiffener webs of hopper and topside tank watertight bulkheads are required to be aligned with the webs of longitudinal stiffeners of sloping plates of inner hull.

A primary supporting member is to be provided in way of any vertical knuckle in longitudinal bulkheads. The distance between the knuckle and the primary supporting member is to be taken not greater than 70 mm. When the knuckle is not vertical, it is to be adequately stiffened by ordinary stiffeners or equivalent means, fitted in line with the knuckle.

Plate floors are to be fitted in the double bottom in line with the plate transverse bulkhead.

### 10.3.2 End connection of ordinary stiffeners

The crossing of ordinary stiffeners through a watertight bulkhead is to be watertight.

In general, end connections of ordinary stiffeners are to be bracketed. If bracketed end connections cannot be applied due to hull lines, etc., they are to be terminated on transverse headers between adjacent longitudinal or if not possible, sniped ends may be accepted, provided the scantling of ordinary stiffeners and corresponding plating are modified accordingly.

### 10.3.3 Sniped end of ordinary stiffener

Sniped ends are not allowed on bulkheads subject to hydrostatic pressure. Where sniped ordinary stiffeners are fitted, the snipe angle is not to be greater than 30 degrees, and their ends are to be extended as far as practicable to the boundary of the bulkhead.

### 10.3.4 Bracketed ordinary stiffeners

Where bracketed ordinary stiffeners are fitted, the arm lengths of end brackets of ordinary stiffeners, as shown in Figs 26 and 27, are to be not less than the following values, in mm:

— for arm length  $a$ :

— brackets of horizontal stiffeners and bottom bracket of vertical stiffeners:

$$a = 100\ell$$

— upper bracket of vertical stiffeners:

$$a = 80\ell$$

— for arm length  $b$ , the greater of

$$b = 80\{(w + 20) / t\}^{0.5}$$

and

$$b = \alpha p s \ell / t$$

where:

$\ell$  = Span, in m, of the stiffener measured between supports

$w$  = Net section modulus, in  $\text{cm}^3$ , of the stiffener

$t$  = Net thickness, in mm, of the bracket

$p$  = Design pressure, in  $\text{kN/m}^2$ , calculated at mid-span

$\alpha$  = Coefficient equal to:

$$\alpha = 4.9 \text{ for tank bulkheads}$$

$$\alpha = 3.6 \text{ for watertight bulkheads.}$$

The connection between the stiffener and the bracket is to be such that the net section modulus of the connection is not less than that of the stiffener.

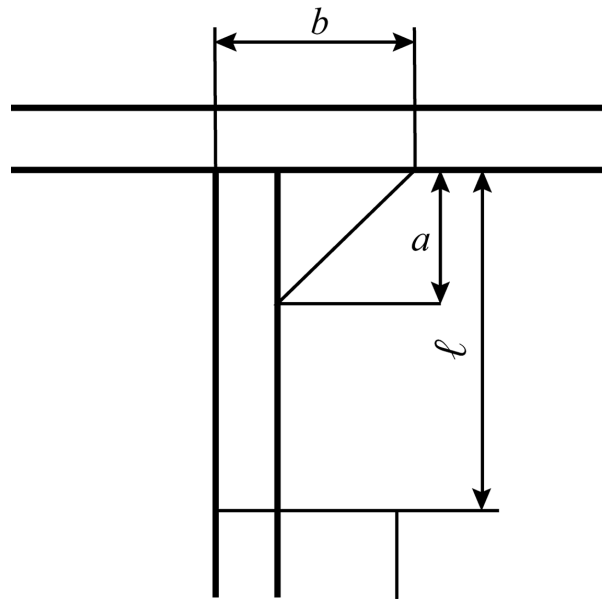

**Fig. 26**  
**Bracket at upper end of ordinary stiffener on plane bulkhead**

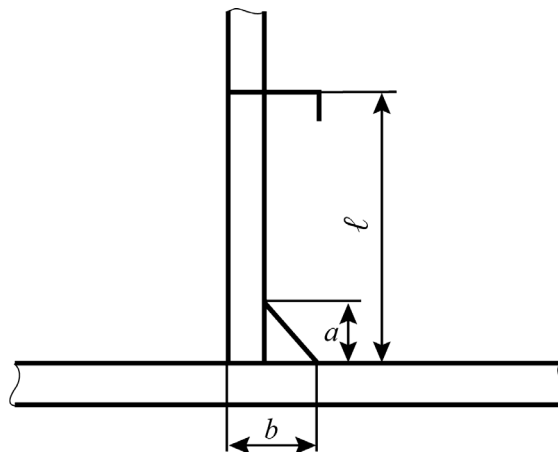

**Fig. 27**  
**Bracket at lower end of ordinary stiffener on plane bulkhead**

## 10.4 Corrugated bulkheads

### 10.4.1 General

For ships of 190 m of length  $L$  and above, the transverse vertically corrugated watertight bulkheads are to be fitted with a lower stool, and with an upper stool below deck. For ships less than 190 m in length  $L$ , corrugations may extend from inner bottom to deck provided the global strength of hull structures are satisfactorily proved for ships having ship length  $L$  of 150 m and above by DSA as required by Ch 7 of the Rules.

### 10.4.2 Construction

The main dimensions  $a$ ,  $R$ ,  $c$ ,  $d$ ,  $t$ ,  $\varphi$  and  $s_C$  of corrugated bulkheads are defined in Fig 28.

The bending radius is not to be less than the following values, in mm:

$$R = 3.0t$$

where :

$t$  = As-built thickness, in mm, of the corrugated plate.

The corrugation angle  $\varphi$  shown in Fig 28 is to be not less than  $55^\circ$ .

When welds in a direction parallel to the bend axis are provided in the zone of the bend, the welding procedures are to be submitted to the Society for approval.

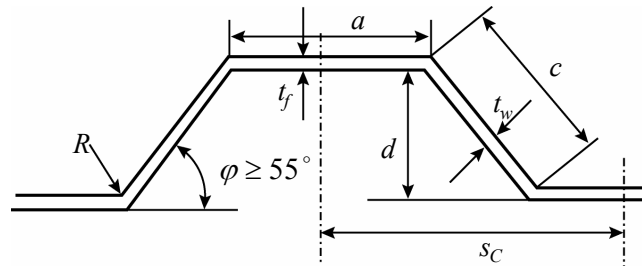

**Fig. 28**  
**Dimensions of a corrugated bulkhead**

### 10.4.3 Actual section modulus of corrugations

The net section modulus of a corrugation may be obtained, in  $\text{cm}^3$ , from the following formula:

$$w = \left[ \frac{d(3at_f + ct_w)}{6} \right] 10^{-3}$$

where:

$t_f, t_w$  = Net thickness of the plating of the corrugation, in mm, shown in Fig 28  
 $d, a, c$  = Dimensions of the corrugation, in mm, shown in Fig 28.

Where the web continuity is not ensured at ends of the bulkhead, the net section modulus of a corrugation is to be obtained, in  $\text{cm}^3$ , from the following formula:

$$w = 0.5 a t_f d \cdot 10^{-3}$$

### 10.4.4 Span of corrugations

The span  $\ell_C$  of the corrugations is to be taken as the distance shown in Fig 29.

For the definition of  $\ell_C$ , the internal end of the upper stool is not to be taken more than a distance from the deck at the centre line equal to:

- 3 times the depth of corrugation, in general
- 2 times the depth of corrugation, for rectangular stool.

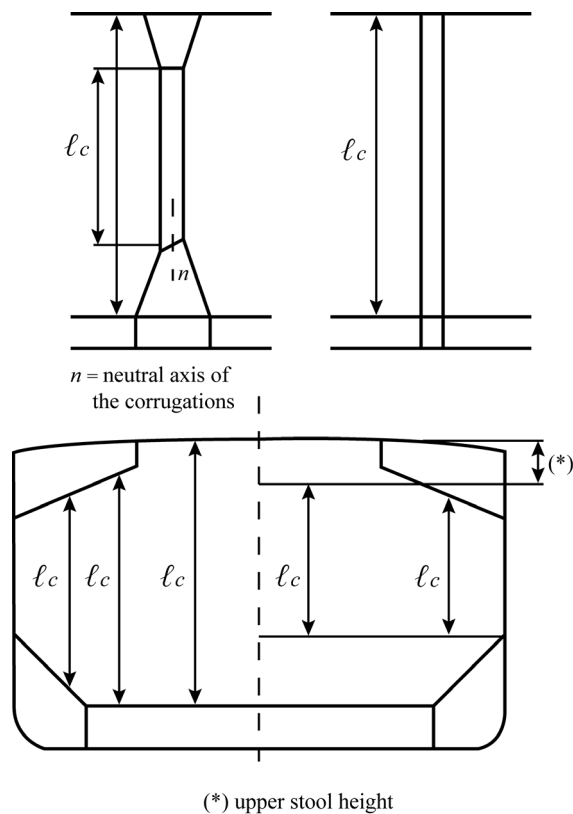

**Fig. 29**  
 Span of the corrugations

#### 10.4.5 Structural arrangements

The strength continuity of corrugated bulkheads is to be ensured at the ends of corrugations.

Where corrugated bulkheads are cut in way of primary supporting members, attention is to be paid to ensure correct alignment of corrugations on each side of the primary member.

Where vertically corrugated transverse bulkheads or longitudinal bulkheads are welded on the inner bottom plate, floors or girders are to be fitted in way of flanges of corrugations, respectively.

In general, the first vertical corrugation connected to the boundary structures is to have a width not smaller than typical width of corrugation flange.

#### 10.4.6 Bulkhead stools

Plate diaphragms or web frames are to be fitted in bottom stools in way of the double bottom longitudinal girders or plate floors, as the case may be.

Brackets or deep webs are to be fitted to connect the upper stool to the deck transverse or hatch end beams, as the case may be.

#### 10.4.7 Lower stool

The lower stool, when fitted, is to have a height in general not less than 3 times the depth of the corrugations.

The ends of stool side ordinary stiffeners, when fitted in a vertical plane, are to be attached to brackets at the upper and lower ends of the stool.

The distance  $d$  from the edge of the stool top plate to the surface of the corrugation flange is to be in accordance with Fig 30.

The stool bottom is to be installed in line with double bottom floors or girders as the case may be, and is to have a width not less than 2.5 times the mean depth of the corrugation.

The stool is to be fitted with diaphragms in line with the longitudinal double bottom girders or floors as the case may be, for effective support of the corrugated bulkhead. Scallops in the brackets and diaphragms in way of the connections to the stool top plate are to be avoided.

Where corrugations are cut at the lower stool, corrugated bulkhead plating is to be connected to the stool top



plate by full penetration welds. The stool side plating is to be connected to the stool top plate and the inner bottom plating by either full penetration or deep penetration welds. The supporting floors are to be connected to the inner bottom by either full penetration or deep penetration weld.

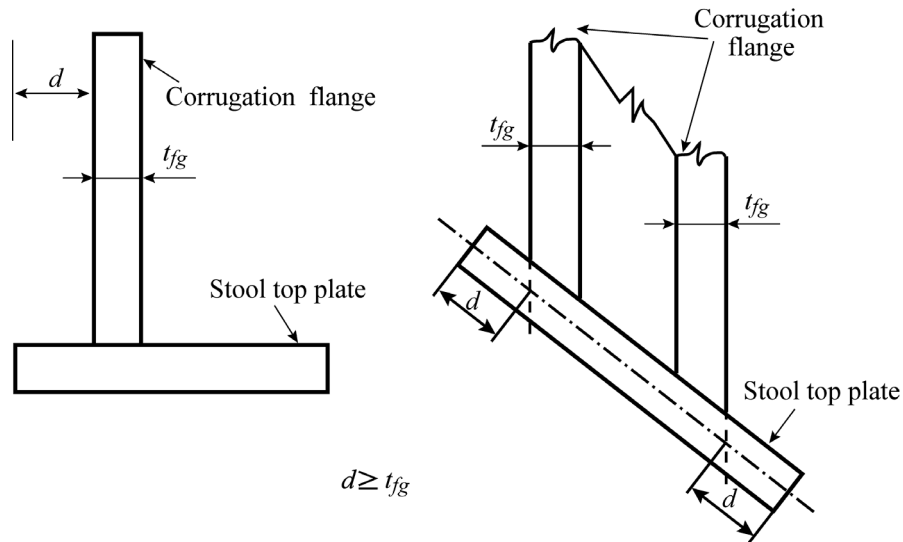

**Fig. 30**  
Permitted distance,  $d$ , from the edge of the stool top plate to the surface of the corrugation flange

#### 10.4.8 Upper stool

The upper stool, when fitted, is to have a height in general between two and three times the depth of corrugations. Rectangular stools are to have a height in general equal to twice the depth of corrugations, measured from the deck level and at the hatch side girder.

The upper stool of transverse bulkhead is to be properly supported by deck girders or deep brackets between the adjacent hatch end beams.

The width of the upper stool bottom plate is generally to be the same as that of the lower stool top plate. The stool top of non-rectangular stools is to have a width not less than twice the depth of corrugations.

The ends of stool side ordinary stiffeners when fitted in a vertical plane, are to be attached to brackets at the upper and lower end of the stool.

The stool is to be fitted with diaphragms in line with and effectively attached to longitudinal deck girders extending to the hatch end coaming girders or transverse deck primary supporting members as the case may be, for effective support of the corrugated bulkhead.

Scallops in the brackets and diaphragms in way of the connection to the stool bottom plate are to be avoided.

#### 10.4.9 Alignment

At deck, if no upper stool is fitted, two transverse or longitudinal reinforced beams as the case may be, are to be fitted in line with the corrugation flanges.

At bottom, if no lower stool is fitted, the corrugation flanges are to be in line with the supporting floors or girders.

The weld of corrugations and floors or girders to the inner bottom plating are to be full penetration ones.

The cut-outs for connections of the inner bottom longitudinals to double bottom floors are to be closed by collar plates. The supporting floors or girders are to be connected to each other by suitably designed shear plates.

Stool side plating is to be aligned with the corrugation flanges. Lower stool side vertical stiffeners and their brackets in the stool are to be aligned with the inner bottom structures as longitudinals or similar, to provide appropriate load transmission between these stiffening members.

Lower stool side plating is not to be knuckled anywhere between the inner bottom plating and the stool top plate.

#### 10.4.10 Effective width of the compression flange

The effective width of the corrugation flange in compression to be considered for the strength check of the

bulkhead is to be obtained, in m, from the following formula:

$$b_{ef} = C_E a$$

where:

$C_E$  = Coefficient to be taken equal to:

$$C_E = \frac{2.25}{\beta} - \frac{1.25}{\beta^2} \quad \text{for } \beta > 1.25$$

$$C_E = 1.0 \quad \text{for } \beta \leq 1.25$$

$\beta$  = Coefficient to be taken equal to:

$$\beta = 10^3 \frac{a}{t_f} \sqrt{\frac{R_{eH}}{E}}$$

$a$  = Width, in m, of the corrugation flange (see Fig 28)

$t_f$  = Net flange thickness, in mm.

#### 10.4.11 Effective shedder plates

Effective shedder plates are those which:

- are not knuckled
- are welded to the corrugations and the lower stool top plate according to Ch 11
- are fitted with a minimum slope of 45°, their lower edge being in line with the lower stool side plating
- have thickness not less than 75% of that required for the corrugation flanges
- have material properties not less than those required for the flanges.

#### 10.4.12 Effective gusset plates

Effective gusset plates are those which:

- are in combination with shedder plates having thickness, material properties and welded connections as requested for shedder plates in [10.4.11],
- have a height not less than half of the flange width,
- are fitted in line with the lower stool side plating,
- are welded to the lower stool top plate, corrugations and shedder plates according to Ch 11,
- have thickness and material properties not less than those required for the flanges.

#### 10.4.13 (Void)

#### 10.4.14 (Void)

#### 10.4.15 (Void)

### 10.5 Non-tight bulkheads

#### 10.5.1 Non-tight bulkheads not acting as pillars

Non-tight bulkheads not acting as pillars are to be provided with bulkhead stiffeners with a maximum spacing equal to:

- 0.9 m, for transverse bulkheads
- two frame spacings, with a maximum of 1.5 m, for longitudinal bulkheads.

The depth of bulkhead stiffener is not to be less than 1/12 of stiffener length. The net thickness of bulkhead stiffener is not to be less than the minimum thickness required for the considered bulkhead plate.

#### 10.5.2 Non-tight bulkheads acting as pillars

Non-tight bulkheads acting as pillars are to be provided with bulkhead stiffeners with a maximum spacing equal to:

- two frame spacings, when the frame spacing does not exceed 0.75 m,
- one frame spacing, when the frame spacing is greater than 0.75 m.

Each vertical stiffener, in association with a width of plating equal to 35 times the plating net thickness or 1/12 of stiffener length, whichever is the smaller, is to comply with the applicable requirements in Ch 6, Sec 2, for the load being supported.

In the case of non-tight bulkheads supporting longitudinally framed decks, vertical girders are to be provided in way of deck transverse.

## **10.6 Watertight bulkheads of trunks and tunnels**

### **10.6.1**

Ref. SOLAS Ch. II-1, Part B, Reg. 19.1

*Watertight trunks, tunnels, duct keels and ventilators are to be of the same strength as watertight bulkheads at corresponding levels. The means used for making them watertight, and the arrangements adopted for closing openings in them, are to be to the satisfaction of the Society.*

## **11 Pillars**

### **11.1 General**

#### **11.1.1**

Pillars are to be fitted, as far as practicable, in the same vertical line. If not possible, effective means are to be provided for transmitting their loads to the supports below.

#### **11.1.2**

Pillars are to be provided in line with the double bottom girder or as close thereto as practicable, and the structure above and under the pillars is to be of sufficient strength to provide effective distribution of the load. Where pillars connected to the inner bottom are not located in way of the intersection of floors and girders, partial floors or girders or equivalent structures suitable to support the pillars are to be arranged.

#### **11.1.3**

Pillars provided in tanks are to be of solid or open section type. Pillars located in spaces intended for products which may produce explosive gases are to be of open section type.

#### **11.1.4 Connections**

Heads and heels of pillars are to be secured by thick doubling plates and brackets as necessary. Where the pillars are likely to be subjected to tensile loads such as those in tanks, the head and heel of pillars are to be efficiently secured to withstand the tensile loads and the doubling plates replaced by insert plate.

In general, the net thickness of doubling plates is to be not less than 1.5 times the net thickness of the pillar.

Pillars are to be attached at their heads and heels by continuous welding.



# Chapter 4

## Design Loads

---

Section 1 General

Section 2 Ship Motions and Accelerations

Section 3 Hull Girder Loads

Section 4 Load Cases

Section 5 External Pressures

Section 6 Internal Pressures and Forces

Section 7 Loading Conditions

Section 8 Loading Manual and Loading Instrument

Appendix 1 Hold Mass Curves

Appendix 2 Standard Loading Condition for Direct Strength Analysis

Appendix 3 Loading Condition for fatigue assessment



## **SECTION 1 GENERAL**

### **1 General**

#### **1.1**

##### **1.1.1**

The equivalent design wave (EDW) method is used to set the design loads which include lateral loads normal to plating and hull girder loads in still water and in waves.

##### **1.1.2**

External hydrostatic pressure and internal static pressure due to cargo and ballast are considered as lateral loads in still water. External hydrodynamic pressure and internal inertial pressure due to cargo and ballast are considered as lateral loads in waves.

##### **1.1.3**

Still water vertical shear force and bending moment, wave-induced vertical shear force and bending moment and wave-induced horizontal bending moment are considered as the hull girder loads.

##### **1.1.4**

The stresses due to the lateral loads in waves and the hull girder loads in waves are to be combined using load combination factors determined for each equivalent design wave.

## SECTION 2 SHIP MOTIONS AND ACCELERATIONS

### Symbols

For symbols not defined in this Section, refer to Ch 1, Sec 4.

$a_0$  = Acceleration parameter, taken equal to:

$$a_0 = f_p (1.58 - 0.47C_B) \left( \frac{2.4}{\sqrt{L}} + \frac{34}{L} - \frac{600}{L^2} \right)$$

$T_R$  = Roll period, in s, defined in [2.1.1]

$\theta$  = Single roll amplitude, in deg, defined in [2.1.1]

$T_P$  = Pitch period, in s, defined in [2.2.1]

$\Phi$  = Single pitch amplitude, in deg, defined in [2.2.1]

$f_p$  = Coefficient corresponding to the probability level, taken equal to:

$f_p = 1.0$  for strength assessments corresponding to the probability level of  $10^{-8}$

$f_p = 0.5$  for strength assessments corresponding to the probability level of  $10^{-4}$

### 1 General

#### 1.1

##### 1.1.1

Ship motions and accelerations are assumed to be periodic. The motion amplitudes, defined by the formulae in this Section, are half of the crest to trough amplitudes.

##### 1.1.2

As an alternative to the formulae in this Section, the Society may accept the values of ship motions and accelerations derived from direct calculations or obtained from model tests, when justified on the basis of the ship's characteristics and intended service. In general, the values of ship motions and accelerations to be determined are those which can be reached with a probability level of  $10^{-8}$  or  $10^{-4}$ . In any case, the model tests or the calculations, including the assumed sea scatter diagrams and spectra, are to be submitted to the Society for approval.

### 2 Ship absolute motions and accelerations

#### 2.1 Roll

##### 2.1.1

The roll period  $T_R$ , in s, and the single roll amplitude  $\theta$ , in deg, are given by:

$$T_R = \frac{2.3k_r}{\sqrt{GM}}$$

$$\theta = \frac{9000(1.25 - 0.025T_R)f_p k_b}{(B + 75)\pi}$$

where:

$k_b$  = Coefficient taken equal to:

$k_b = 1.2$  for ships without bilge keel



$k_b = 1.0$  for ships with bilge keel

$k_r$  = Roll radius of gyration, in m, in the considered loading condition. When  $k_r$  is not known, the values indicated in Table 1 may be assumed.

$GM$  = Metacentric height, in m, in the considered loading condition. When  $GM$  is not known, the values indicated in Table 1 may be assumed.

<b>Table 1 Values of <math>k_r</math> and <math>GM</math></b>			
Loading condition		$k_r$	$GM$
Full load condition	alternate or homogeneous loading	$0.35B$	$0.12B$
	Steel coil loading	$0.42B$	$0.24B$
Normal ballast condition		$0.45B$	$0.33B$
Heavy ballast condition		$0.40B$	$0.25B$

## 2.2 Pitch

### 2.2.1

The pitch period  $T_p$ , in s, and the single pitch amplitude  $\Phi$ , in deg, are given by:

$$T_p = \sqrt{\frac{2\pi\lambda}{g}}$$

$$\Phi = f_p \frac{960}{L} \sqrt[4]{\frac{V}{C_B}}$$

where:

$$\lambda = 0.6 \left( 1 + \frac{T_{LC}}{T_S} \right) L$$

## 2.3 Heave

### 2.3.1

The vertical acceleration due to heave, in  $m/s^2$ , is given by:

$$a_{heave} = a_0 g$$

## 2.4 Sway

### 2.4.1

The transverse acceleration due to sway, in  $m/s^2$ , is given by:

$$a_{sway} = 0.3a_0 g$$

## 2.5 Surge

### 2.5.1

The longitudinal acceleration due to surge, in  $m/s^2$ , is given by:

$$a_{surge} = 0.2a_0 g$$

## 3 Ship relative accelerations

### 3.1 General

#### 3.1.1

At any point, the accelerations in  $X$ ,  $Y$  and  $Z$  directions are the acceleration components which result from the ship absolute motions and accelerations defined in [2.1] to [2.5].

## 3.2 Accelerations

### 3.2.1

The reference values of the longitudinal, transverse and vertical accelerations at any point are obtained from the following formulae:

— In longitudinal direction:

$$a_x = C_{XG}g \sin \Phi + C_{XS}a_{surge} + C_{XP}a_{pitch\ x}$$

— In transverse direction:

$$a_y = C_{YG}g \sin \theta + C_{YS}a_{sway} + C_{YR}a_{roll\ y}$$

— In vertical direction:

$$a_z = C_{ZH}a_{heave} + C_{ZR}a_{roll\ z} + C_{ZP}a_{pitch\ z}$$

where:

$C_{XG}$ ,  $C_{XS}$ ,  $C_{XP}$ ,  $C_{YG}$ ,  $C_{YS}$ ,  $C_{YR}$ ,  $C_{ZH}$ ,  $C_{ZR}$  and  $C_{ZP}$ : Load combination factors defined in Ch 4, Sec 4, [2.2]

$a_{pitch\ x}$  = Longitudinal acceleration due to pitch, in  $m/s^2$

$$a_{pitch\ x} = \Phi \frac{\pi}{180} \left( \frac{2\pi}{T_P} \right)^2 R$$

$a_{roll\ y}$  = Transverse acceleration due to roll, in  $m/s^2$

$$a_{roll\ y} = \theta \frac{\pi}{180} \left( \frac{2\pi}{T_R} \right)^2 R$$

$a_{roll\ z}$  = Vertical acceleration due to roll, in  $m/s^2$

$$a_{roll\ z} = \theta \frac{\pi}{180} \left( \frac{2\pi}{T_R} \right)^2 y$$

$a_{pitch\ z}$  = Vertical acceleration due to pitch, in  $m/s^2$

$$a_{pitch\ z} = \Phi \frac{\pi}{180} \left( \frac{2\pi}{T_P} \right)^2 \{(x - 0.45L)\}$$

where  $\{(x - 0.45L)\}$  is to be taken not less than  $0.2L$

$$R = z - \min\left(\frac{D}{4} + \frac{T_{LC}}{2}, \frac{D}{2}\right)$$

$x, y, z$  =  $X, Y$  and  $Z$  co-ordinates, in m, of any point considered with respect to the reference co-ordinate system defined in Ch 1, Sec 4.

## SECTION 3 HULL GIRDER LOADS

### Symbols

For symbols not defined in this Section, refer to Ch 1, Sec 4.

- $x$  =  $X$  co-ordinate, in m, of the calculation point with respect to the reference co-ordinate system  
 $f_p$  = Coefficient corresponding to the probability, defined in Ch 4, Sec 2.

### 1 General

#### 1.1 Sign conventions of bending moments and shear forces

##### 1.1.1

Absolute values are to be taken for bending moments and shear forces introduced in this Section. The sign of bending moments and shear forces is to be considered according to Sec 4, Table 3. The sign conventions of vertical bending moments, horizontal bending moments and shear forces at any ship transverse section are as shown in Fig 1, namely:

- the vertical bending moments  $M_{SW}$  and  $M_{WV}$  are positive when they induce tensile stresses in the strength deck (hogging bending moment) and are negative in the opposite case (sagging bending moment)
- the horizontal bending moment  $M_{WH}$  is positive when it induces tensile stresses in the starboard and is negative in the opposite case.
- the vertical shear forces  $Q_{SW}$ ,  $Q_{WV}$  are positive in the case of downward resulting forces preceding and upward resulting forces following the ship transverse section under consideration, and is negative in the opposite case.

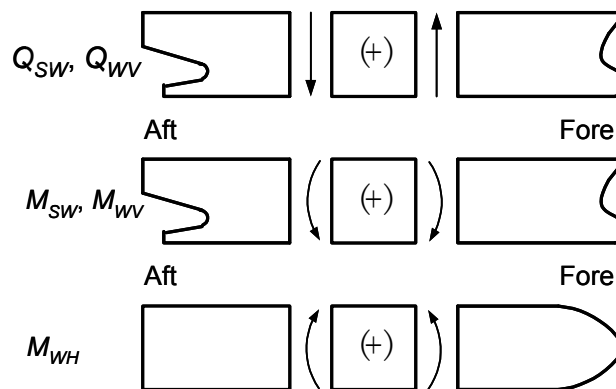

Fig. 1  
Sign conventions for shear forces  $Q_{SW}$ ,  $Q_{WV}$  and bending moments  $M_{SW}$ ,  $M_{WV}$  and  $M_{WH}$

### 2 Still water loads

#### 2.1 General

##### 2.1.1

In general the vertical still water bending moment and the shear force of the individual loading condition is to be applied. The shipbuilder has to submit for each of the loading condition defined in Ch 4, Sec 7 a longitudinal strength calculation.

The values of still water vertical bending moment and shear force are to be treated as the upper limits with respect to hull girder strength.

In general, the following design cargo and ballast loading conditions, based on amount of bunker, fresh water and stores at departure and arrival, are to be considered for the  $M_{SW}$  and  $Q_{SW}$  calculations. Where the amount

and disposition of consumables at any intermediate stage of the voyage are considered more severe, calculations for such intermediate conditions are to be submitted in addition to those for departure and arrival conditions. Also, where any ballasting and/or deballasting is intended during voyage, calculations of the intermediate condition just before and just after ballasting and/or deballasting any ballast tank are to be submitted and where approved included in the loading manual for guidance.

### 2.1.2 Partially filled ballast tanks in ballast loading conditions

Ballast loading conditions involving partially filled peak and/or other ballast tanks at departure, arrival or during intermediate conditions are not permitted to be used as design conditions unless:

- design stress limits are satisfied for all filling levels between empty and full, and
- for **BC-A** and **BC-B** ships, longitudinal strength of hull girder in flooded condition according to Ch 5, Sec 1, [2.1.3] is complied with for all filling levels between empty and full.

To demonstrate compliance with all filling levels between empty and full, it will be acceptable if, in each condition at departure, arrival, and where required by [2.1.1], any intermediate condition, the tanks intended to be partially filled are assumed to be:

- empty
- full
- partially filled at intended level.

Where multiple tanks are intended to be partially filled, all combinations of empty, full or partially filled at intended level for those tanks are to be investigated.

### 2.1.3 Partially filled ballast tanks in cargo loading conditions

In cargo loading conditions, the requirement in [2.1.2] applies to the peak tanks only.

### 2.1.4 Sequential ballast water exchange

Requirements of [2.1.2] and [2.1.3] are not applicable to ballast water exchange using the sequential method.

## 2.2 Still water bending moment

### 2.2.1

The design still water bending moments  $M_{SW,H}$  and  $M_{SW,S}$  at any hull transverse section are the maximum still water bending moments calculated, in hogging and sagging conditions, respectively, at that hull transverse section for the loading conditions, as defined in [2.1.1]. Greater values may be considered if defined by the Designer.

### 2.2.2

If the design still water bending moments are not defined, at a preliminary design stage, at any hull transverse section, the longitudinal distributions shown in Fig 2 may be considered.

In Fig 2,  $M_{SW}$  is the design still water bending moment amidships, in hogging or sagging conditions, whose values are to be taken not less than those obtained, in kN.m, from the following formulae:

- hogging conditions:

$$M_{SW,H} = 175CL^2B(C_B + 0.7)10^{-3} - M_{WV,H}$$

- sagging conditions:

$$M_{SW,S} = 175CL^2B(C_B + 0.7)10^{-3} - M_{WV,S}$$

where  $M_{WV,H}$  and  $M_{WV,S}$  are the vertical wave bending moments, in kN.m, defined in [3.1].

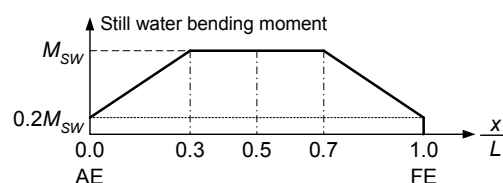

Fig. 2  
Preliminary still water bending moment distribution

## 2.3 Still water shear force

### 2.3.1

The design still water shear force  $Q_{SW}$  at any hull transverse section is the maximum positive or negative shear force calculated, at that hull transverse section, for the loading conditions, as defined in [2.1.1]. Greater values may be considered if defined by the Designer.

## 2.4 Still water bending moment and still water shear force in flooded condition

### 2.4.1

The still water bending moments  $M_{SW,F}$ , in hogging and sagging conditions, and the still water shear force  $Q_{SW,F}$ , in flooded condition are to be determined for the flooding scenario considering each cargo hold individually flooded up to the equilibrium waterline.

This means that double side spaces may not be considered flooded, and the cargo holds may not be considered completely flooded, but only up to the equilibrium waterline.

### 2.4.2

To calculate the weight of ingressed water, the following assumptions are to be made:

- The permeability of empty cargo spaces and volume left in loaded cargo spaces above any cargo is to be taken as 0.95.
- Appropriate permeabilities and bulk densities are to be used for any cargo carried. For iron ore, a minimum permeability of 0.3 with a corresponding bulk density of 3.0 t/m<sup>3</sup> is to be used. For cement, a minimum permeability of 0.3 with a corresponding bulk density of 1.3 t/m<sup>3</sup> is to be used. In this respect, “permeability” for solid bulk cargo means the ratio of the floodable volume between the particles, granules or any larger pieces of the cargo, to the gross volume of the bulk cargo.

For packed cargo conditions (such as steel mill products), the actual density of the cargo should be used with a permeability of zero.

### 2.4.3

To quantify the effects of ingressed water on the hull girder still water bending moments and still water shear forces, specific calculations are to be carried out. The loading conditions on which the design of the ship has been based are to be considered and, for each of them, the cargo holds are to be considered as being individually flooded up to the equilibrium waterline. The still water bending moments and still water shear forces are therefore to be calculated for any combination of considered loading conditions and flooded cargo holds.

## 3 Wave loads

### 3.1 Vertical wave bending moments

#### 3.1.1 Intact condition

The vertical wave bending moments in intact condition at any hull transverse section are obtained, in kN.m, from the following formulae:

— hogging conditions:  $M_{WV,H} = 190F_M f_p CL^2 BC_B 10^{-3}$

— sagging conditions:  $M_{WV,S} = 110F_M f_p CL^2 B(C_B + 0.7)10^{-3}$

where:

$F_M$  = Distribution factor defined in Table 1 (see also Fig 3).

Hull transverse section location	Distribution factor $F_M$
$0 \leq x < 0.4L$	$2.5 \frac{x}{L}$
$0.4L \leq x \leq 0.65L$	1.0
$0.65L < x \leq L$	$2.86 \left(1 - \frac{x}{L}\right)$

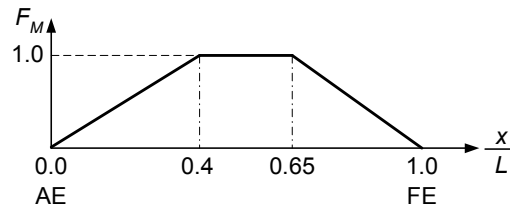

**Fig. 3**  
**Distribution factor  $F_M$**

### 3.1.2 Flooded condition

The vertical wave bending moments in flooded condition at any hull transverse section are obtained, in kN.m, from the following formula:

$$M_{WV,F} = 0.8M_{WV}$$

where  $M_{WV}$  is defined in [3.1.1].

### 3.1.3 Harbour condition

The vertical wave bending moments in harbour condition at any hull transverse section are obtained, in kN.m, from the following formula:

$$M_{WV,P} = 0.4M_{WV}$$

where  $M_{WV}$  is defined in [3.1.1].

## 3.2 Vertical wave shear force

### 3.2.1 Intact condition

The vertical wave shear force in intact condition at any hull transverse section is obtained, in kN, from the following formula:

$$Q_{WV} = 30F_Q f_p CLB(C_B + 0.7)10^{-2}$$

where:

$F_Q$  = Distribution factor defined in Table 2 for positive and negative shear forces (see also Fig 4).

Hull transverse section location	Distribution factor $F_Q$	
	Positive wave shear force	Negative wave shear force
$0 \leq x < 0.2L$	$4.6A \frac{x}{L}$	$4.6 \frac{x}{L}$
$0.2L \leq x \leq 0.3L$	0.92A	0.92
$0.3L < x < 0.4L$	$(9.2A - 7) \left(0.4 - \frac{x}{L}\right) + 0.7$	$2.2 \left(0.4 - \frac{x}{L}\right) + 0.7$
$0.4L \leq x \leq 0.6L$	0.7	0.7
$0.6L < x < 0.7L$	$3 \left(\frac{x}{L} - 0.6\right) + 0.7$	$(10A - 7) \left(\frac{x}{L} - 0.6\right) + 0.7$
$0.7L \leq x \leq 0.85L$	1	A
$0.85L < x \leq L$	$6.67 \left(1 - \frac{x}{L}\right)$	$6.67A \left(1 - \frac{x}{L}\right)$

Note :

$$A = \frac{190C_B}{110(C_B + 0.7)}$$

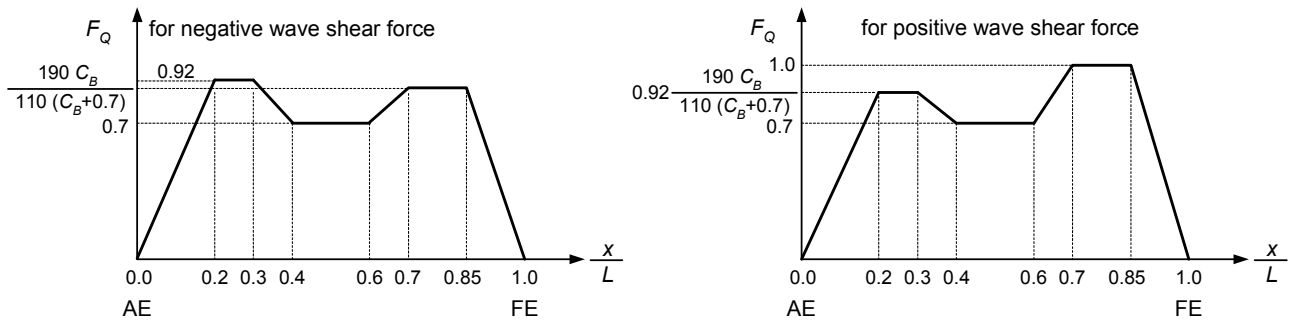

**Fig. 4**  
**Distribution factor  $F_Q$**

### 3.2.2 Flooded condition

The vertical wave shear force in flooded condition at any hull transverse section are obtained, in kN, from the following formula:

$$Q_{WV,F} = 0.8Q_{WV}$$

where  $Q_{WV}$  is defined in [3.2.1].

### 3.2.3 Harbour condition

The vertical wave shear force in harbour condition at any hull transverse section are obtained, in kN, from the following formula:

$$Q_{WV,P} = 0.4Q_{WV}$$

where  $Q_{WV}$  is defined in [3.2.1].

## 3.3 Horizontal wave bending moment

### 3.3.1

The horizontal wave bending moment at any hull transverse section, in kN.m, is given by:

$$M_{WH} = \left(0.3 + \frac{L}{2000}\right) F_M f_p C L^2 T_{LC} C_B$$

where  $F_M$  is the distribution factor defined in [3.1.1].

## 3.4 Wave torsional moment

### 3.4.1

The wave torsional moment at any hull transverse section, in kN.m, is given by:

$$M_{WT} = f_p (|M_{WT1}| + |M_{WT2}|)$$

where:

$$M_{WT1} = 0.4 \cdot C \sqrt{\frac{L}{T}} \cdot B^2 D \cdot C_B \cdot F_{T1}$$

$$M_{WT2} = 0.22 C L B^2 C_B \cdot F_{T2}$$

$F_{T1}, F_{T2}$  = Distribution factors, defined as follows:

$$F_{T1} = \sin\left(\frac{2\pi x}{L}\right)$$

$$F_{T2} = \sin^2\left(\frac{\pi x}{L}\right)$$

## SECTION 4 LOAD CASES

### Symbols

For symbols not defined in this Section, refer to Ch 1, Sec 4.

$a_{surge}$ ,  $a_{pitch\ x}$ ,  $a_{sway}$ ,  $a_{roll\ y}$ ,  $a_{heave}$ ,  $a_{roll\ z}$ ,  $a_{pitch\ z}$  = Components of accelerations, defined in Ch 4, Sec 2.

## 1 General

### 1.1 Application

#### 1.1.1

The load cases described in this section are those to be used for:

- the local strength analysis of plating and ordinary stiffeners and primary supporting members according to the applicable requirements of Ch 6, Sec 1, Ch 6, Sec 2 and Ch 6, Sec 4 respectively,
- the direct strength analysis of structural members, according to the applicable requirements of Ch 7,
- the fatigue check of structural details, according to the applicable requirements of Ch 8.

#### 1.1.2

For the local strength analysis and for the direct strength analysis, the load cases are the mutually exclusive load cases H1, H2, F1, F2, R1, R2, P1 and P2 described in [2].

### 1.2 Equivalent design wave

#### 1.2.1

Regular waves that generate response values equivalent to the long-term response values of the load components considered being predominant to the structural members are set as Equivalent Design Waves (EDWs). They consist of:

- regular waves when the vertical wave bending moment becomes maximum in head sea (EDW “H”)
- regular waves when the vertical wave bending moment becomes maximum in following sea (EDW “F”)
- regular waves when the roll motion becomes maximum (EDW “R”)
- regular waves when the hydrodynamic pressure at the waterline becomes maximum (EDW “P”)

The definitions of wave crest and wave trough in the EDW “H” and EDW “F” are given in Fig 1. The definitions of weather side down and weather side up for the EDW “R” and EDW “P” are given in Fig 2.

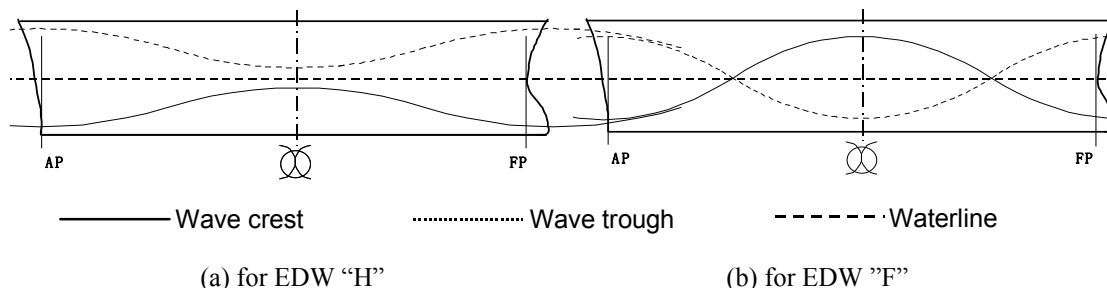

**Fig. 1**  
Definition of wave crest and wave trough for EDWs “H” and “F”



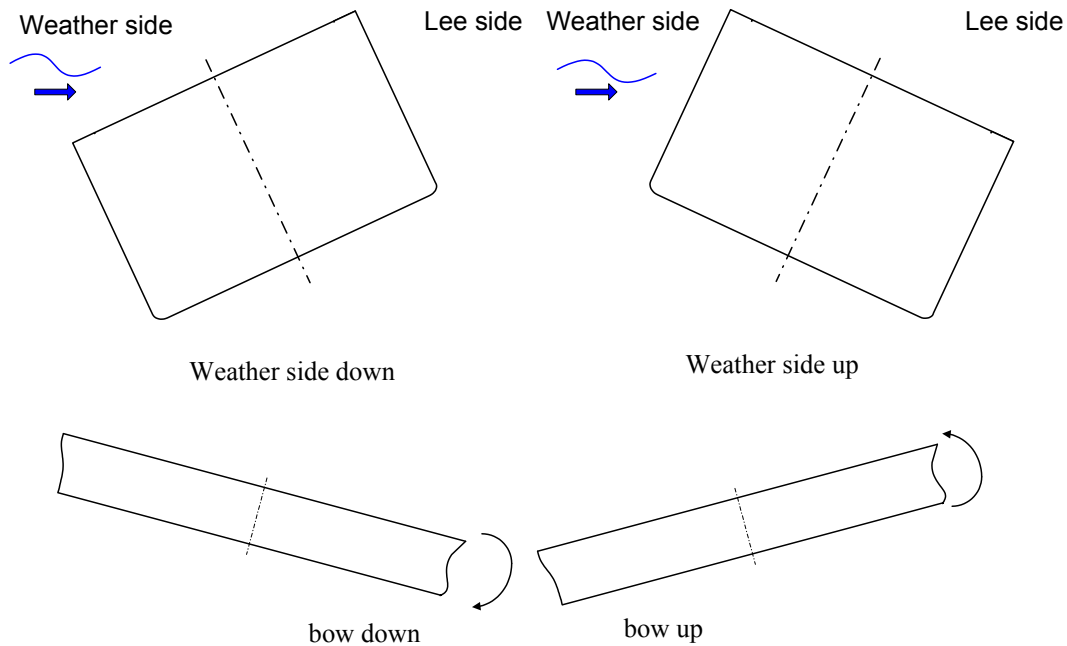

**Fig. 2**  
**Definitions of ship motion**

## 2 Load cases

### 2.1 General

#### 2.1.1

The load cases corresponding to the Equivalent Design Waves (EDWs) are defined in Table 1. The corresponding hull girder loads and motions of the ship are indicated in Table 2. If the ship structure or the ship loading condition is not symmetrical with respect to the centreline plane of ship, the load cases (R1, R2, P1 and P2) corresponding to the beam conditions in which the encounter wave comes from the starboard (in this case the starboard is the weather side), should be also included in the structural strength assessment.

Load case	H1	H2	F1	F2	R1	R2	P1	P2
EDW	"H"		"F"		"R"		"P"	
Heading	Head		Follow		Beam (Port: weather side)		Beam (Port: weather side)	
Effect	Max. Bending Moment		Max. Bending Moment		Max. Roll		Max. Ext. Pressure	
	Sagging	Hogging	Sagging	Hogging	(+)	(-)	(+)	(-)

Load case	H1	H2	F1	F2	R1	R2	P1	P2
Vert. BM & SF	Yes		Yes		-		Yes	
Hor. BM	-		-		Yes		-	
Heave	Down	Up	-	-	Down	Up	Down	Up
Pitch	Bow down	Bow up	-	-	-	-	-	-
Roll	-	-	-	-	Stbd up	Stbd down	Stbd up	Stbd down
Surge	Stern	Bow	-	-	-	-	-	-
Sway	-	-	-	-	-	-	Port	Stbd

## 2.2 Load combination factors

### 2.2.1

The hull girder loads and the acceleration components to be considered in each load case H1, H2, F1, F2, R1, R2, P1 and P2 are to be obtained by multiplying the reference value of each component by the relevant load combination factor LCF defined in Table 3.

### 2.2.2

The still water vertical bending moment is to be added to the hull girder loads in waves, calculated with load combination factors.

### 2.2.3

The internal loads are the sum of static pressures or forces induced by the weights carried, including those carried on decks, and of inertial pressures or forces induced by the accelerations on these weights and calculated with load combination factors.

	<i>LCF</i>	<i>H1</i>	<i>H2</i>	<i>F1</i>	<i>F2</i>	<i>R1</i>	<i>R2</i>	<i>P1</i>	<i>P2</i>
$M_{WV}$	$C_{WV}$	-1	1	-1	1	0	0	$0.4 - \frac{T_{LC}}{T_S}$	$\frac{T_{LC}}{T_S} - 0.4$
$Q_{WV}$	$C_{QW}^{(1)}$	-1	1	-1	1	0	0	$0.4 - \frac{T_{LC}}{T_S}$	$\frac{T_{LC}}{T_S} - 0.4$
$M_{WH}$	$C_{WH}$	0	0	0	0	$1.2 - \frac{T_{LC}}{T_S}$	$\frac{T_{LC}}{T_S} - 1.2$	0	0
$a_{surge}$	$C_{XS}$	-0.8	0.8	0	0	0	0	0	0
$a_{pitch\ x}$	$C_{XP}$	1	-1	0	0	0	0	0	0
$g\sin\Phi$	$C_{XG}$	1	-1	0	0	0	0	0	0
$a_{sway}$	$C_{YS}$	0	0	0	0	0	0	1	-1
$a_{roll\ y}$	$C_{YR}$	0	0	0	0	1	-1	0.3	-0.3
$g\sin\theta$	$C_{YG}$	0	0	0	0	1	-1	0.3	-0.3
$a_{heave}$	$C_{ZH}$	$0.6 \frac{T_{LC}}{T_S}$	$-0.6 \frac{T_{LC}}{T_S}$	0	0	$\frac{\sqrt{L}}{40}$	$-\frac{\sqrt{L}}{40}$	1	-1
$a_{roll\ z}$	$C_{ZR}$	0	0	0	0	1	-1	0.3	-0.3
$a_{pitch\ z}$	$C_{ZP}$	1	-1	0	0	0	0	0	0

(1) The LCF for  $C_{QW}$  is only used for the aft part of midship section. The inverse value of it should be used for the forward part of the midship section.

## SECTION 5 EXTERNAL PRESSURES

### Symbols

For symbols not defined in this Section, refer to Ch 1, Sec 4.

- $L_2$  = Rule length  $L$ , but to be taken not greater than 300 m  
 $C$  = Wave coefficient, as defined in Ch 1, Sec 4, [2.3.1]  
 $\lambda$  = Wave length, in m, corresponding to the load case, defined in [1.3.1], [1.4.1], and [1.5.1]  
 $f_p$  = Coefficient corresponding to the probability, defined in Ch 4, Sec 2  
 $T_{LCi}$  = Draught in the considered cross section, in m, in the considered loading condition  
 $B_i$  = Moulded breadth at the waterline, in m, in the considered cross section  
 $x, y, z$  =  $X, Y$  and  $Z$  co-ordinates, in m, of the load point with respect to the reference co-ordinate system defined in Ch 1, sec 4.

### 1 External sea pressures on side shell and bottom

#### 1.1 General

##### 1.1.1

The total pressure  $p$  at any point of the hull, in  $\text{kN/m}^2$ , to be obtained from the following formula is not to be negative:

$$p = p_S + p_W$$

Where:

- $p_S$  = Hydrostatic pressure defined in [1.2]  
 $p_W$  = Wave pressure equal to the hydrodynamic pressure defined in [1.3], [1.4] or [1.5], as the case may be, and corrected according to [1.6].

#### 1.2 Hydrostatic pressure

##### 1.2.1

The hydrostatic pressure  $p_S$  at any point of the hull, in  $\text{kN/m}^2$ , corresponding to the draught in still water is obtained, for each loading condition, from the formulae in Table 1 (see also Fig 1).

Table 1 Hydrostatic pressure $p_S$	
Location	Hydrostatic pressure, $p_S$ , in $\text{kN/m}^2$
Points at and below the waterline ( $z \leq T_{LCi}$ )	$\rho g(T_{LCi} - z)$
Points above the waterline ( $z > T_{LCi}$ )	0

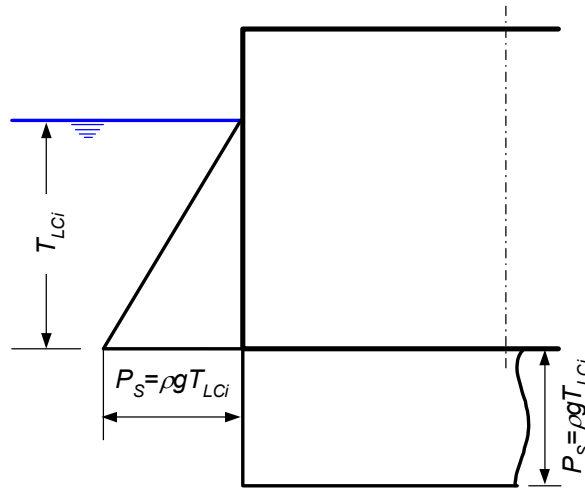

**Fig. 1**  
Hydrostatic pressure  $p_S$

### 1.3 Hydrodynamic pressures for load cases H1, H2, F1 and F2

#### 1.3.1

The hydrodynamic pressures  $p_H$  and  $p_F$ , for load cases H1, H2, F1 and F2, at any point of the hull below the waterline are to be obtained, in  $\text{kN/m}^2$ , from Table 2.

The distribution of pressure  $p_{F2}$  is schematically given in Fig 2.

Load case	Hydrodynamic pressure, in $\text{kN/m}^2$
H1	$p_{H1} = -k_\ell k_p p_{HF}$
H2	$p_{H2} = k_\ell k_p p_{HF}$
F1	$p_{F1} = -p_{HF}$
F2	$p_{F2} = p_{HF}$

where:

$$p_{HF} = 3f_p f_{nl} C \sqrt{\frac{L + \lambda - 12S}{L}} \left( \frac{z}{T_{LCi}} + \frac{|2y|}{B_i} + 1 \right);$$

with  $\frac{|2y|}{B} \leq 1.0$  and  $z$  is to be taken not greater than  $T_{LCi}$

$f_{nl}$  = Coefficient considering nonlinear effect, taken equal to:

$$f_{nl} = 0.9 \quad \text{for the probability level of } 10^{-8}$$

$$f_{nl} = 1.0 \quad \text{for the probability level of } 10^{-4}$$

$k_\ell$  = Amplitude coefficient in the longitudinal direction of the ship, taken equal to:

$$k_\ell = 1 + \frac{12}{C_B} \left( 1 - \sqrt{\frac{|2y|}{B}} \right) \left| \frac{x}{L} - 0.5 \right|^3 \quad \text{for } 0.0 \leq x/L \leq 0.5$$

$$k_\ell = 1 + \frac{6}{C_B} \left( 3 - \frac{|4y|}{B} \right) \left| \frac{x}{L} - 0.5 \right|^3 \quad \text{for } 0.5 \leq x/L \leq 1.0$$

$k_p$  = Phase coefficient in the longitudinal direction of the ship, taken equal to:

$$k_p = \left( 1.25 - \frac{T_{LC}}{T_S} \right) \cos \left( \frac{2\pi|x - 0.5L|}{L} \right) - \frac{T_{LC}}{T_S} + 0.25,$$

for local strength analysis in conditions other than full load condition, for direct strength analysis and for fatigue strength assessments

$k_p = -1.0$ , for local strength analysis in full load condition

$\lambda$  = Wave length, in m, taken equal to:

$$\lambda = 0.6 \left( 1 + \frac{T_{LC}}{T_S} \right) L \quad \text{for load cases H1 and H2}$$

$$\lambda = 0.6 \left( 1 + \frac{2 T_{LC}}{3 T_S} \right) L \quad \text{for load cases F1 and F2}$$

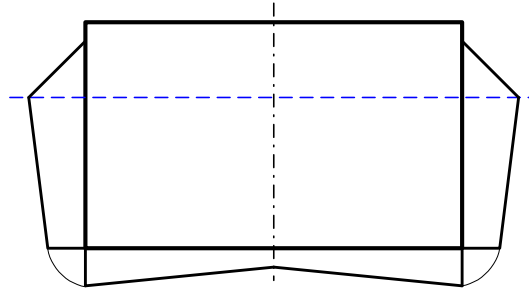

**Fig. 2**  
Distribution of hydrodynamic pressure  $p_{F2}$  at midship

## 1.4 Hydrodynamic pressures for load cases R1 and R2

### 1.4.1

The hydrodynamic pressures  $p_R$ , for load cases R1 and R2, at any point of the hull below the waterline are to be obtained, in  $\text{kN/m}^2$ , from the following formulae. The distribution of pressure  $p_{R1}$  is schematically given in Fig 3.

$$p_{R1} = f_{nl} \left( 10y \sin \theta + 0.88 f_p C \sqrt{\frac{L + \lambda - 125}{L}} \left( \frac{|2y|}{B} + 1 \right) \right)$$

$$p_{R2} = -p_{R1}$$

where:

$f_{nl}$  = Coefficient considering nonlinear effect, taken equal to:

$$f_{nl} = 0.8 \text{ for the probability level of } 10^{-8}$$

$$f_{nl} = 1.0 \text{ for the probability level of } 10^{-4}$$

$$\lambda = \frac{g}{2\pi} T_R^2$$

$y$  =  $Y$  co-ordinate of the load point, in m, taken positive on the portside.

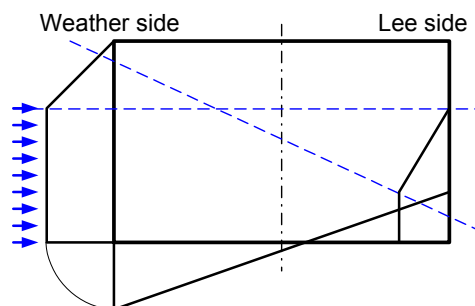

**Fig. 3**  
Distribution of hydrodynamic pressure  $p_{R1}$  at midship

## 1.5 Hydrodynamic pressures for load cases P1 and P2

### 1.5.1

The hydrodynamic pressures  $p_P$ , for the load cases P1 and P2, at any point of the hull below the waterline are to be obtained, in  $\text{kN/m}^2$ , from Table 3. The distribution of pressure  $p_{P1}$  is schematically given in Fig 4.

Table 3 Hydrodynamic pressures for load cases P1 and P2		
Load case	Hydrodynamic pressure, in $\text{kN/m}^2$	
	weather side	lee side
P1	$p_{P1} = p_P$	$p_{P1} = p_P/3$
P2	$p_{P2} = -p_P$	$p_{P2} = -p_P/3$

where:

$$p_P = 4.5 f_p f_{nl} C \sqrt{\frac{L + \lambda - 125}{L}} \left( 2 \frac{|z|}{T_{LCi}} + 3 \frac{|2y|}{B} \right)$$

$f_{nl}$  = Coefficient considering nonlinear effect, taken equal to:

$$f_{nl} = 0.65 \text{ for the probability level of } 10^{-8}$$

$$f_{nl} = 1.0 \text{ for the probability level of } 10^{-4}$$

$$\lambda = \left( 0.2 + 0.4 \frac{T_{LC}}{T_S} \right) L$$

$y$  = Y co-ordinate of the load point, in m, as defined in [1.4.1]

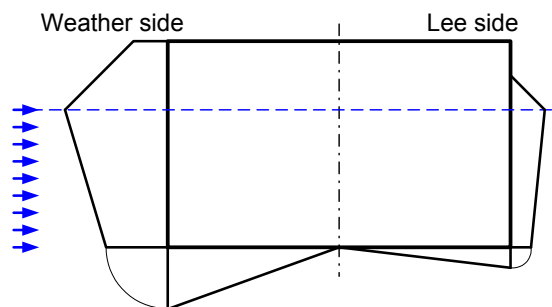

Fig. 4  
Distribution of hydrodynamic pressure  $p_{P1}$  at midship

## 1.6 Correction to hydrodynamic pressures

### 1.6.1

For the positive hydrodynamic pressure at the waterline (in load cases H1, H2, F2, R1, R2 and P1), the hydrodynamic pressure  $P_{W,C}$  at the side above waterline is given (see Fig 5), in  $\text{kN/m}^2$ , by:

$$— p_{W,C} = p_{W,WL} + \rho g (T_{LCi} - z) \text{ for } T_{LCi} \leq z \leq h_W + T_{LCi}$$

$$— p_{W,C} = 0 \text{ for } z \geq h_W + T_{LCi}$$

where:

$p_{W,WL}$  = positive hydrodynamic pressure at the waterline for the considered load case

$$h_W = \frac{p_{W,WL}}{\rho g}$$

### 1.6.2

For the negative hydrodynamic pressure at the waterline (in load cases H1, H2, F1, R1, R2, and P2), the hydrodynamic pressure  $P_{W,C}$  under the waterline is given (see Fig 5), in  $\text{kN/m}^2$ , by:

$p_{W,C} = p_W$ , without being taken less than  $\rho g(z - T_{LCi})$

where

$p_W$  = Negative hydrodynamic pressure under the waterline for the considered load case

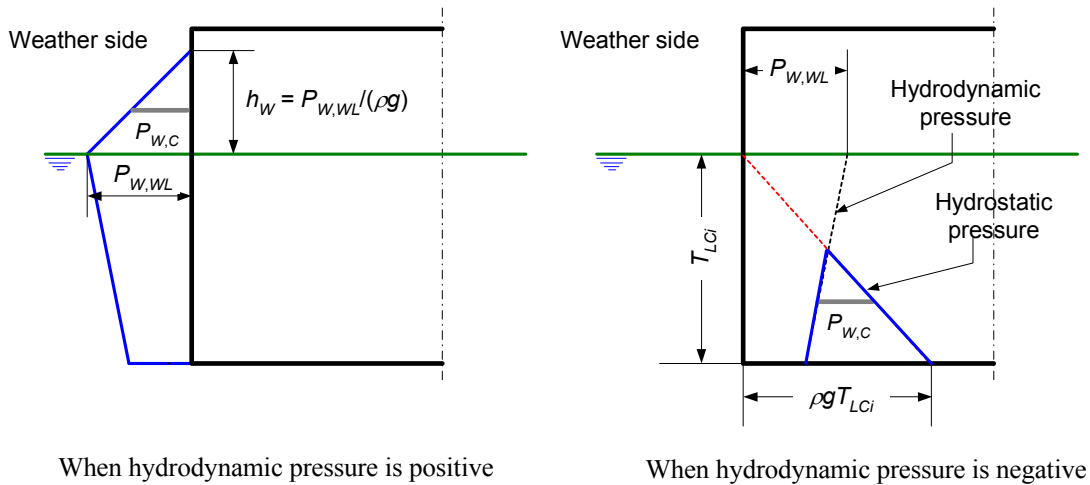

Fig. 5  
Correction to hydrodynamic pressure

## 2 External pressures on exposed decks

### 2.1 General

#### 2.1.1

The external pressures on exposed decks are to be applied for the local scantling check of the structures on exposed deck but not applied for fatigue strength assessment.

If a breakwater is fitted on the exposed deck, no reduction in the external pressures defined in [2.2] and [2.3] is allowed for the area of the exposed deck located aft of the breakwater.

### 2.2 Load cases H1, H2, F1 and F2

#### 2.2.1

The external pressure  $p_D$ , for load cases H1, H2, F1 and F2, at any point of an exposed deck is to be obtained, in  $\text{kN/m}^2$ , from the following formula:

$$p_D = \varphi p_W$$

where:

$p_W$  = Pressure obtained from the formulae in Table 4

$\varphi$  = Coefficient defined in Table 5.

Table 4 Pressures on exposed decks for H1, H2, F1 and F2		
Location	Pressure $p_W$ , in $\text{kN/m}^2$	
	$L_{LL} \geq 100 \text{ m}$	$L_{LL} < 100 \text{ m}$
$0 \leq x_{LL}/L_{LL} \leq 0.75$	34.3	$14.9 + 0.195 L_{LL}$
$0.75 < x_{LL}/L_{LL} < 1$	$34.3 + (14.8 + a(L_{LL} - 100)) \left( 4 \frac{x_{LL}}{L_{LL}} - 3 \right)$	$12.2 + \frac{L_{LL}}{9} \left( 5 \frac{x_{LL}}{L_{LL}} - 2 \right) + 3.6 \frac{x_{LL}}{L_{LL}}$
where: $a$ = Coefficient taken equal to: $a = 0.0726$ for Type B freeboard ships $a = 0.356$ for Type B-60 or Type B-100 freeboard ships. $x_{LL}$ = X coordinate of the load point measured from the aft end of the freeboard length $L_{LL}$ .		

<b>Table 5 Coefficient for pressure on exposed decks</b>	
<i>Exposed deck location</i>	$\varphi$
Freeboard deck	1.00
Superstructure deck, including forecastle deck	0.75
1 <sup>st</sup> tier of deckhouse	0.56
2 <sup>nd</sup> tier of deckhouse	0.42
3 <sup>rd</sup> tier of deckhouse	0.32
4 <sup>th</sup> tier of deckhouse	0.25
5 <sup>th</sup> tier of deckhouse	0.20
6 <sup>th</sup> tier of deckhouse	0.15
7 <sup>th</sup> tier of deckhouse and above	0.10

## 2.3 Load cases R1, R2, P1 and P2

### 2.3.1

The external pressure  $p_D$ , for load cases R1, R2, P1 and P2, at any point of an exposed deck is to be obtained, in kN/m<sup>2</sup>, from the following formula:

$$p_D = 0.4 \varphi p_W$$

where:

$p_W$  = Hydrodynamic pressure at side of the exposed deck for the load cases P1, P2, R1 and R2, in kN/m<sup>2</sup>, can be determined by [1.6] at the  $z$  co-ordinate.  $p_W$  is to be taken greater one of the hydrodynamic pressures  $p_{W,C}$  at both sides of the exposed deck (portside and starboard), and is not to be taken less than zero.

$\varphi$  = Coefficient defined in Table 5.

## 2.4 Load carried on exposed deck

### 2.4.1 Pressure due to distributed load

If a distributed load is carried on an exposed deck, the static pressure  $p_S$  corresponding to this load is to be defined by the Designer and, in general, is not to be taken less than 10 kN/m<sup>2</sup>.

The total pressure  $p$  due to this load is to be considered not simultaneously to the pressures defined in [2.2] and [2.3]. It is to be taken equal, in kN/m<sup>2</sup>, to the greater value obtained from the following formulae:

$$p = p_S + p_W$$

$$p = p_D$$

where:

$p_S$  = Static pressure due to the distributed load carried, if any

$p_W$  = Dynamic pressure due to the distributed load carried, in kN/m<sup>2</sup>, taken equal to:

$$p_W = \frac{a_z}{g} p_S$$

$a_z$  = Vertical acceleration at the centre of gravity of the distributed load carried for the load case considered, in m/s<sup>2</sup>, obtained by the formulae defined in Ch 4, Sec 2, [3.2]

$p_D$  = Pressure for the exposed deck, for the load case considered, as defined in [2.2.1] and [2.3.1].

### 2.4.2 Concentrated forces due to unit load

If a unit load is carried on an exposed deck, the static and dynamic forces due to the unit load carried are considered.

The total force  $F$  due to this load is to be considered not simultaneously to the pressures defined in [2.2] and [2.3]. It is to be taken, in kN, equal to value obtained from the following formula:

$$F = F_S + F_W$$

where:



$F_S$  = .Static force due to the unit load carried, in kN, taken equal to:

$$F_S = m_U g$$

$F_W$  = Dynamic force due to unit load carried, in kN, taken equal to:

$$F_W = m_U a_Z$$

$m_U$  = Mass of the unit load carried, in t

$a_Z$  = Vertical acceleration at the centre of gravity of the unit load carried for the load case considered, in  $m/s^2$ , obtained by the formulae defined in Ch 4, Sec 2, [3.2].

### 3 External pressures on superstructure and deckhouses

#### 3.1 Exposed decks

##### 3.1.1

External pressures on exposed decks of superstructures and deckhouses are to be obtained according to [2].

#### 3.2 Exposed wheel house tops

##### 3.2.1

The lateral pressure for exposed wheel house tops, in  $kN/m^2$ , is not to be taken less than:

$$p = 12.5$$

#### 3.3 Sides of superstructures

##### 3.3.1

The lateral pressure for sides of superstructures, in  $kN/m^2$ , is to be obtained from the following formula:

$$p_{SI} = 2.1 C_f f_p c_F (C_B + 0.7) \frac{20}{10 + z - T}$$

$f_p$  = Probability factor, taken equal to:

$f_p = 0.75$  for ordinary stiffeners and primary supporting members

$f_p = 1.0$  for plate panels

$c_F$  = Distribution factor according to Table 6.

Location	$c_F$
$0 \leq \frac{x}{L} < 0.2$	$1.0 + \frac{5}{C_B} \left( 0.2 - \frac{x}{L} \right)$ , without taking $x/L$ less than 0.1
$\frac{x}{L} \geq 0.2$	1.0

#### 3.4 End bulkhead of superstructure and deckhouse

##### 3.4.1

The lateral pressure, in  $kN/m^2$ , for determining the scantlings is to be obtained from the greater of the following formulae:

$$p_A = nc[bC - (z - T)]$$

$$p_A = p_{A \min}$$

where:

$n$  = Coefficient defined in Table 7, depending on the tier level.

The lowest tier is normally that tier which is directly situated above the uppermost continuous deck to which the depth  $D$  is to be measured. However, where the actual distance (D-T) exceeds the minimum non-corrected tabular freeboard according to ILLC as amended by at least one standard superstructure height as defined in Ch 1, Sec 4, [3.18.1], this tier may be defined as the 2<sup>nd</sup> tier and

$c$  = the tier above as the 3<sup>rd</sup> tier  
= Coefficient taken equal to:

$$c = 0.3 + 0.7 \frac{b_1}{B_1}$$

For exposed parts of machinery casings,  $c$  is not to be taken less than 1.0

$b_1$  = Breadth of deckhouse at the position considered

$B_1$  = Actual maximum breadth of ship on the exposed weather deck at the position considered.

$b_1/B_1$  is not to be taken less than 0.25

$b$  = Coefficient defined in Table 8

$x$  =  $X$  co-ordinate, in m, of the calculation point for the bulkhead considered. When determining sides of a deckhouse, the deckhouse is to be subdivided into parts of approximately equal length, not exceeding each, and is to be taken as the  $X$  co-ordinate of the centre of each part considered.

$z$  =  $Z$  co-ordinate, in m, of the midpoint of stiffener span, or to the middle of the plate field

$\ell$  = Span, in m, to be taken as the superstructure height or deckhouse height respectively, and not less than 2.0 m

$p_{Amin}$  = Minimum lateral pressure, in kN/m<sup>2</sup>, defined in Table 9.

Table 7 Coefficient $n$		
Type of bulkhead	Location	$n$
Unprotected front	Lowest tier	$20 + \frac{L_2}{12}$
	Second tier	$10 + \frac{L_2}{12}$
	Third tier and above	$5 + \frac{L_2}{15}$
Protected front	All tiers	$5 + \frac{L_2}{15}$
Sides	All tiers	$5 + \frac{L_2}{15}$
Aft end	Abaft amidships	$7 + \frac{L_2}{100} - 8 \frac{x}{L_2}$
	Forward of amidships	$5 + \frac{L_2}{100} - 4 \frac{x}{L_2}$

Table 8 Coefficient $b$	
Location of bulkhead	$b$
$\frac{x}{L} < 0.45$	$1.0 + \left( \frac{\frac{x}{L} - 0.45}{C_B + 0.2} \right)^2$
$\frac{x}{L} \geq 0.45$	$1.0 + 1.5 \left( \frac{\frac{x}{L} - 0.45}{C_B + 0.2} \right)^2$

Where:

$C_B$  = Block coefficient with  $0.6 \leq C_B \leq 0.8$ . When determining scantlings of aft ends forward of amidships,  $C_B$  need not be taken less than 0.8.

Table 9 Minimum lateral pressure $p_{Amin}$	
	$p_{Amin}$ in kN/m <sup>2</sup>

$L$	Lowest tier of unprotected fronts	Elsewhere <sup>(1)</sup>
$90 < L \leq 250$	$25 + \frac{L}{10}$	$12.5 + \frac{L}{20}$
$L > 250$	50	25

(1) For the 4<sup>th</sup> tier and above,  $p_{Amin}$  is to be taken equal to 12.5 kN/m<sup>2</sup>.

## 4 Pressure in bow area

### 4.1 Bow flare area pressure

#### 4.1.1

The bow pressure, in kN/m<sup>2</sup>, to be considered for the reinforcement of the bow flare area is to be obtained from the following formula:

$$p_{FB} = K(p_S + p_W)$$

where:

$p_S, p_W$  = Hydrostatic pressure and maximum hydrodynamic pressures among load cases H, F, R and P, calculated in normal ballast condition at  $T_B$

$K$  = Coefficient taken equal to:

$$K = \frac{c_{FL} (0.2V + 0.6\sqrt{L})^2}{42C(C_B + 0.7) \left( 1 + \frac{20}{C_B} \left( \frac{x}{L} - 0.7 \right)^2 \right)} (10 + z - T_B)$$

to be taken not less than 1.0

$c_{FL}$  = Coefficient taken equal to:

$c_{FL} = 0.8$  in general

$$c_{FL} = \frac{0.4}{1.2 - 1.09 \sin \alpha}$$

where the flare angle  $\alpha$  is greater than 40°

Where, the flare angle  $\alpha$  at the load calculation point is to be measured in plane of the frame between a vertical line and the tangent to the side shell plating. (see Fig 6).

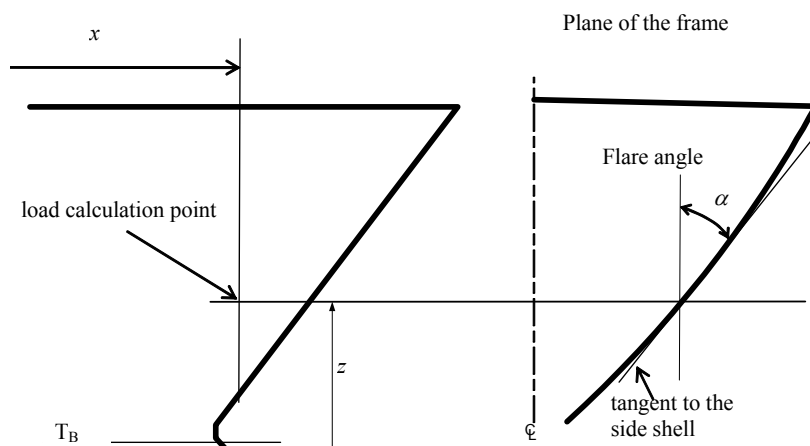

Fig. 6  
The definition of the flare angle

### 4.2 Design bottom slamming pressure

#### 4.2.1

The bottom slamming pressure, in kN/m<sup>2</sup>, to be considered for the reinforcement of the flat bottom forward is

to be obtained from the following formula:

$$— p_{SL} = 162c_1c_{SL}\sqrt{L} \quad \text{for } L \leq 150 \text{ m}$$

$$— p_{SL} = 1984c_1c_{SL}(1.3 - 0.002L) \quad \text{for } L > 150 \text{ m}$$

where:

$c_1$  = Coefficient taken equal to:

$$c_1 = 3.6 - 6.5 \left( \frac{T_{BFP}}{L} \right)^{0.2}, \text{ to be taken not greater than 1.0}$$

$T_{BFP}$  = Smallest design ballast draught, in m, defined at forward perpendicular for normal ballast conditions. Where the sequential method for ballast water exchange is intended to be applied,  $T_{BFP}$  is to be considered for the sequence of exchange.

$c_{SL}$  = Distribution factor taken equal to (see Fig 6):

$$c_{SL} = 0 \quad \text{for } \frac{x}{L} \leq 0.5$$

$$c_{SL} = \frac{\frac{x}{L} - 0.5}{c_2} \quad \text{for } 0.5 < \frac{x}{L} \leq 0.5 + c_2$$

$$c_{SL} = 1.0 \quad \text{for } 0.5 + c_2 < \frac{x}{L} \leq 0.65 + c_2$$

$$c_{SL} = 0.5 \left( 1 + \frac{1 - \frac{x}{L}}{0.35 - c_2} \right) \quad \text{for } \frac{x}{L} > 0.65 + c_2$$

$c_2$  = Coefficient taken equal to:

$$c_2 = 0.33C_B + \frac{L}{2500}, \text{ to be taken not greater than 0.35.}$$

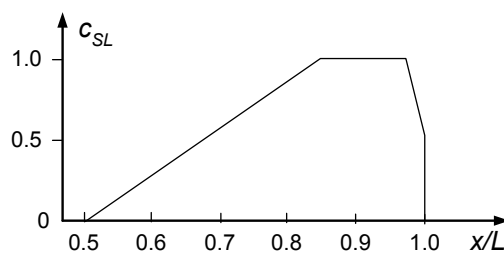

**Fig. 7**  
**Distribution factor  $c_{SL}$**

#### 4.2.2

It is the Master's responsibility to observe, among others, the weather conditions and the draught at forward perpendicular during water ballast exchange operations, in particular when the forward draught during these operations is less than  $T_{BFP}$ .

The above requirement and the draught  $T_{BFP}$  is to be clearly indicated in the operating manuals.

## **5 External pressures on hatch covers**

### **5.1 General**

#### **5.1.1**

If a specific load is carried on a hatch cover, the pressure is to be obtained according to [2.4].

### **5.2 Wave pressure**

#### **5.2.1**

The pressure at any point of the hatch cover is to be obtained according to [2.2.1], considering  $\varphi$  equal to 1.0. However, when the hatchway is located at least one superstructure standard height, as defined in Ch 1, Sec 4, [3.18], higher than the freeboard deck, the pressure  $p_W$  may be taken equal to 34.3 kN/m<sup>2</sup>.

## SECTION 6 INTERNAL PRESSURES AND FORCES

### Symbols

For symbols not defined in this Section, refer to Ch 1, Sec 4.

- $\rho_C$  = Density of the dry bulk cargo, in  $t/m^3$ , taken equal to:
- the value given in Table 1 for ships having a length  $L$  of 150 m and above
  - the maximum density from the loading manual for ships having a length  $L$  less than 150 m

<b>Table 1 Density of dry bulk cargo</b>		
<i>Type of loading</i>	<i>Density</i>	
	<b>BC-A, BC-B</b>	<b>BC-C</b>
Cargo hold loaded up to the upper deck	$\max(M_H/V_H, 1.0)$	1.0
Cargo hold not loaded up to the upper deck	$3.0^{(1)}$	-

(1) Except otherwise specified by the designer.

- $\rho_L$  = Density of internal liquid, in  $t/m^3$ , taken equal to 1.025 when internal liquid is ballast water
- $M_H$  = The actual cargo mass in a cargo hold corresponding to a homogeneously loaded condition at maximum draught, in t
- $V_H$  = Volume, in  $m^3$ , of cargo hold excluding the volume enclosed by hatch coaming
- $K_C$  = Coefficient taken equal to:  
 $K_C = \cos^2 \alpha + (1 - \sin \psi) \sin^2 \alpha$  for inner bottom, hopper tank, transverse and longitudinal bulkheads, lower stool, vertical upper stool, inner side and side shell:  
 $K_C = 0$  for top side tank, upper deck and sloped upper stool:
- $\alpha$  = Angle, in deg, between panel considered and the horizontal plane
- $\psi$  = Assumed angle of repose, in deg, of bulk cargo (considered drained and removed); in the absence of more precise evaluation, the following values may be taken:  
 $\psi = 30^\circ$  in general  
 $\psi = 35^\circ$  for iron ore  
 $\psi = 25^\circ$  for cement
- $h_C$  = Vertical distance, in m, from the inner bottom to the upper surface of bulk cargo, as defined in [1.1.1] or [1.1.2]
- $h_{DB}$  = Height, in m, of the double bottom in the centreline
- $h_{LS}$  = Mean height, in m, of the lower stool, measured from the inner bottom
- $z_{TOP}$  = Z co-ordinate, in m, of the top of the tank, in upright condition
- $z_{BO}$  = Z co-ordinate, in m, of the top of the overflow pipe
- $a_X$  = Longitudinal acceleration at the centre of gravity of the hold or tank considered, in  $m/s^2$ , obtained by the formulae defined in Ch 4, Sec 2, [3.2]
- $a_Y$  = Transverse acceleration at the centre of gravity of the hold or tank considered, in  $m/s^2$ , obtained by the formulae defined in Ch 4, Sec 2, [3.2]
- $a_Z$  = Vertical acceleration at the centre of gravity of the hold or tank considered, in  $m/s^2$ , obtained by the formulae defined in Ch 4, Sec 2, [3.2]
- $B_H$  = Mean breadth of the cargo hold, in m
- $b_{IB}$  = Breadth of inner bottom, in m, as defined on Fig 2
- $D_1$  = Distance, in m, from the base line to the freeboard deck at side amidships
- $s_C$  = Spacing of corrugations, in m; see Ch 3, Sec 6, Fig 28
- $x, y, z$  = X, Y and Z co-ordinates, in m, of the load point with respect to the reference co-ordinate system defined in Ch 1, Sec 4.  $y$  is to be taken positive on the weather side
- $x_G, y_G, z_G$  = X, Y and Z co-ordinates, in m, of the centre of gravity of the hold or tank considered with respect to the reference co-ordinate system defined in Ch 1, Sec 4
- $d_{AP}$  = Distance from the top of air pipe to the top of compartment, in m, taken equal to:  
 $d_{AP} = z_{BO} - z_{TOP}$

# 1 Lateral pressure due to dry bulk cargo

## 1.1 Dry bulk cargo upper surface

### 1.1.1

When the dry bulk cargo density is such that the cargo hold is loaded to the top of hatch coaming, the upper surface of the dry bulk cargo is an equivalent horizontal surface to be determined in considering the same loaded cargo volume in the considered hold bounded by the side shell or inner hull, as the case may be.

For holds of cylindrical shape, the equivalent horizontal surface of the dry bulk cargo may be taken at a distance  $h_C$ , in m, above the inner bottom obtained from the following formula (see Fig 1):

$$h_C = h_{HPU} + h_0$$

where:

$$h_0 = \frac{S_A}{B_H}$$

$$S_A = S_0 + \frac{V_{HC}}{\ell_H}$$

$h_{HPU}$  = Vertical distance, in m, between inner bottom and lower intersection of top side tank and side shell or inner side, as the case may be, as defined in Fig 1

$S_0$  = Shaded area, in m<sup>2</sup>, above the lower intersection of top side tank and side shell or inner side, as the case may be, and up to the upper deck level, as defined in Fig 1

$V_{HC}$  = Volume, in m<sup>3</sup>, enclosed by the hatch coaming.

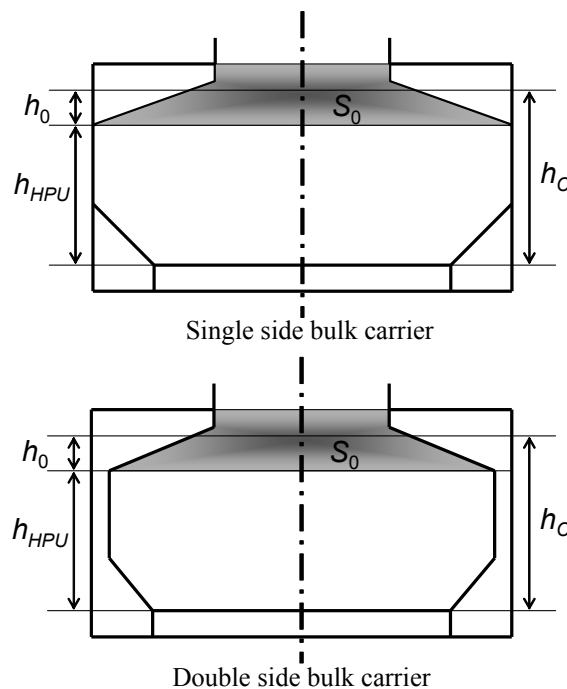

**Fig. 1**  
Definitions of  $h_C$ ,  $h_0$ ,  $h_{HPU}$  and  $S_0$

### 1.1.2

When the dry bulk cargo density is such that the cargo hold is not loaded up to the upper deck, the upper surface of the dry bulk cargo is considered as having a plane surface of width  $B_H/2$  in the centreline and inclined parts with an angle equal to half the angle of repose ( $\psi/2$ ) at sides, and is to be determined in considering the same loaded cargo volume in the considered hold, taken equal to  $M/\rho_C$ .

For holds of cylindrical shape, the upper surface of the dry bulk cargo may be taken at a distance  $h_C$ , in m, above the inner bottom obtained from the following formula (see Fig 2):

$$h_C = h_{HPL} + h_1 + h_2$$

where:

$h_{HPL}$  = Vertical distance, in m, between inner bottom and upper intersection of hopper tank and inner side, as defined in Fig 2.  $h_{HPL}$  is to be taken equal to 0 if there is no hopper tank.

$h_1$  = Vertical distance, in m, obtained from the following formula, see Fig 2.

$$h_1 = \frac{M}{\rho_C \cdot B_H \ell_H} - \frac{B_H + b_{IB}}{2B_H} h_{HPL} - \frac{3}{16} B_H \tan \frac{\psi}{2} + \frac{V_{TS}}{B_H \ell_H}$$

$M$  = Mass, in t, of the bulk cargo to be considered, as defined in Ch 4 Sec 7

$V_{TS}$  = Total volume, in m<sup>3</sup>, of transverse stools at bottom of transverse bulkheads within the concerned cargo hold length  $\ell_H$ . This volume excludes the part of hopper tank passing through the transverse bulkhead.

$h_2$  = Bulk cargo upper surface, in m, depending on  $y$ , given by:

$$h_2 = \frac{B_H}{4} \tan \frac{\psi}{2}, \text{ if } 0 \leq |y| \leq \frac{B_H}{4}$$

$$h_2 = \left( \frac{B_H}{2} - |y| \right) \tan \frac{\psi}{2}, \text{ if } \frac{B_H}{4} \leq |y| \leq \frac{B_H}{2}$$

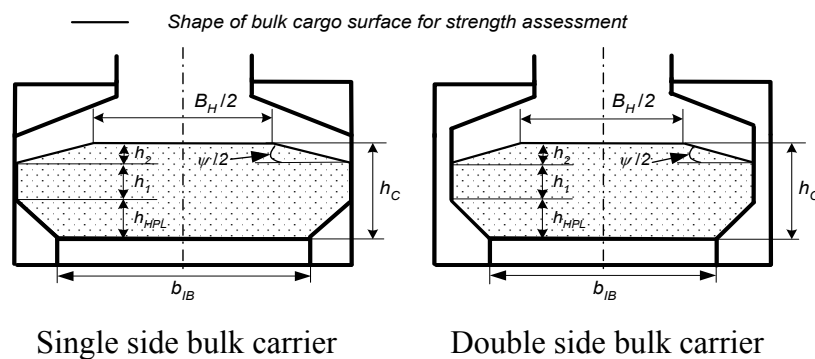

**Fig. 2**  
Definitions of  $h_C$ ,  $h_1$ ,  $h_2$  and  $h_{HPL}$

For holds of non-cylindrical shape, and in case of prescriptive rule requirements, the upper surface of the bulk cargo may be taken at the upper deck level with a density of dry bulk cargo equal to  $M/V_H$ .

## 1.2 Dry bulk cargo pressure in still water

### 1.2.1

The dry bulk cargo pressure in still water  $p_{CS}$ , in kN/m<sup>2</sup>, is given by:

$$p_{CS} = \rho_C g K_C (h_C + h_{DB} - z)$$

## 1.3 Inertial pressure due to dry bulk cargo

### 1.3.1

The inertial pressure induced by dry bulk cargo  $p_{CW}$ , in kN/m<sup>2</sup>, for each load case is given by the following formulae.

— for load case H:

$$p_{CW} = \rho_C [0.25a_x(x - x_G) + K_C a_z(h_C + h_{DB} - z)]$$

— for load case F:

$$p_{CW} = 0$$

— for load cases R and P:

$$p_{CW} = \rho_C [0.25a_y(y - y_G) + K_C a_z(h_C + h_{DB} - z)]$$

$(x - x_G)$  is to be taken as  $0.25\ell_H$  in the load case H1 or  $-0.25\ell_H$  in the load case H2 for local strength by Ch 6 and fatigue check for longitudinal stiffeners by Ch 8.

The total pressure ( $p_{CS} + p_{CW}$ ) is not to be negative.



## 1.4 Shear load due to dry bulk cargo

### 1.4.1

In order to evaluate the total force in the vertical direction, shear load due to dry bulk cargo acting along sloping plates in way of bilge hopper tank and lower stool is to be considered.

The shear load due to dry bulk cargo acting along the sloping members in still water  $p_{CS-S}$  (positive down to inner bottom plating), in  $\text{kN/m}^2$ , is given by:

$$p_{CS-S} = \rho_C g \frac{(1 - K_C)(h_C + h_{DB} - z)}{\tan \alpha}$$

The shear load due to dry bulk cargo acting along the sloping members in waves  $p_{CW-S}$  (positive down to inner bottom plating), in  $\text{kN/m}^2$ , is given by:

— for load cases H, R and P:

$$p_{CW-S} = \rho_C a_Z \frac{(1 - K_C)(h_C + h_{DB} - z)}{\tan \alpha}$$

— for load case F:

$$p_{CW-S} = 0$$

### 1.4.2

In order to evaluate the total force in the longitudinal and transverse directions, shear load due to dry bulk cargo in way of inner bottom plating is to be considered.

The shear load due to dry bulk cargo in the longitudinal direction in waves  $p_{CW-S}$  (positive forward), in  $\text{kN/m}^2$ , is given by:

— for load case H:  $p_{CW-S} = 0.75 \rho_C a_X h_C$

— for load cases F, R and P:  $p_{CW-S} = 0$

The shear load due to dry bulk cargo in the transverse direction in waves  $p_{CW-S}$  (positive weather side), in  $\text{kN/m}^2$ , is given by:

— for load cases R and P:  $p_{CW-S} = 0.75 \rho_C a_Y h_C$

— for load cases H and F:  $p_{CW-S} = 0$

## 2 Lateral pressure due to liquid

### 2.1 Pressure due to liquid in still water

#### 2.1.1

The liquid pressure in still water  $p_{BS}$ , in  $\text{kN/m}^2$ , is given by the greater of the following values:

$$p_{BS} = \rho_L g (z_{TOP} - z + 0.5d_{AP})$$

$$p_{BS} = \rho_L g (z_{TOP} - z) + 100P_{PV}$$

where:

$P_{PV}$  = Setting pressure, in bar, of safety valves to be considered if any

For local strength assessments, the static pressure  $p_{BS}$  is to be taken not less than  $25 \text{ kN/m}^2$ .

#### 2.1.2

When checking ballast water exchange operations by means of the flow through method, the static pressure  $p_{BS}$  for local strength assessments and direct strength analysis by Ch 7 is to be not less than:

$$p_{BS} = \rho_L g (z_{TOP} - z + d_{AP}) + 25$$

Additional calculation may be required where piping or pumping arrangements may lead to a higher pressure.

### 2.1.3

For fatigue strength assessment, the liquid pressure in still water  $p_{BS}$ , in  $\text{kN/m}^2$ , is given by the following formula.

$$p_{BS} = \rho_L g (z_{TOP} - z)$$

If the  $p_{BS}$  is negative,  $p_{BS}$  is to be taken equal to 0.

Where the considered load point is located in the fuel oil, other oils or fresh water tanks, liquids are assumed to be fulfilled up to the half height of the tanks and  $z_{TOP}$  is taken to the Z coordinate of the liquid surface at the upright condition

## 2.2 Inertial pressure due to liquid

### 2.2.1

The inertial pressure due to liquid  $p_{BW}$ , in  $\text{kN/m}^2$ , for each load case is given as follows. When checking ballast water exchange operations by means of the flow through method, the inertial pressure due to ballast water is not to be considered for local strength assessments and direct strength analysis.

- for load case H:  $p_{BW} = \rho_L [a_Z(z_{TOP} - z) + a_X(x - x_B)]$   
( $x - x_B$ ) is to be taken as  $0.75\ell_H$  in the load case H1 or  $-0.75\ell_H$  in the load case H2 for local strength by Ch 6 and fatigue check for longitudinal stiffeners by Ch 8
- for load case F:  $p_{BW} = 0$
- for load cases R and P:  $p_{BW} = \rho_L [a_Z(z_B - z) + a_Y(y - y_B)]$

where:

- $x_B$  = X co-ordinate, in m, of the aft end of the tank when the bow side is downward, or of the fore end of the tank when the bow side is upward, as defined in Fig 3
- $y_B$  = Y co-ordinate, in m, of the tank top located at the most lee side when the weather side is downward, or of the most weather side when the weather side is upward, as defined in Fig 3
- $z_B$  = Z co-ordinate of the following point:
  - for completely filled spaces: the tank top
  - for ballast hold: the top of the hatch coaming.

The reference point B is defined as the upper most point after rotation by the angle  $\varphi$  between the vertical axis and the global acceleration vector  $\vec{A}_G$  shown in Fig 3.  $\varphi$  is obtained from the following formulae:

- load cases H1 and H2:

$$\varphi = \tan^{-1} \left( \frac{|a_X|}{g \cos \Phi + a_Z} \right)$$

- load cases R1(P1) and R2(P2):

$$\varphi = \tan^{-1} \left( \frac{|a_Y|}{g \cos \theta + a_Z} \right)$$

where:

- $\theta$  = Single roll amplitude, in deg, defined in Ch 4, Sec 2, [2.1.1]
- $\Phi$  = Single pitch amplitude, in deg, defined in Ch 4, Sec 2, [2.2.1]

The total pressure ( $p_{BS} + p_{BW}$ ) is not to be negative.

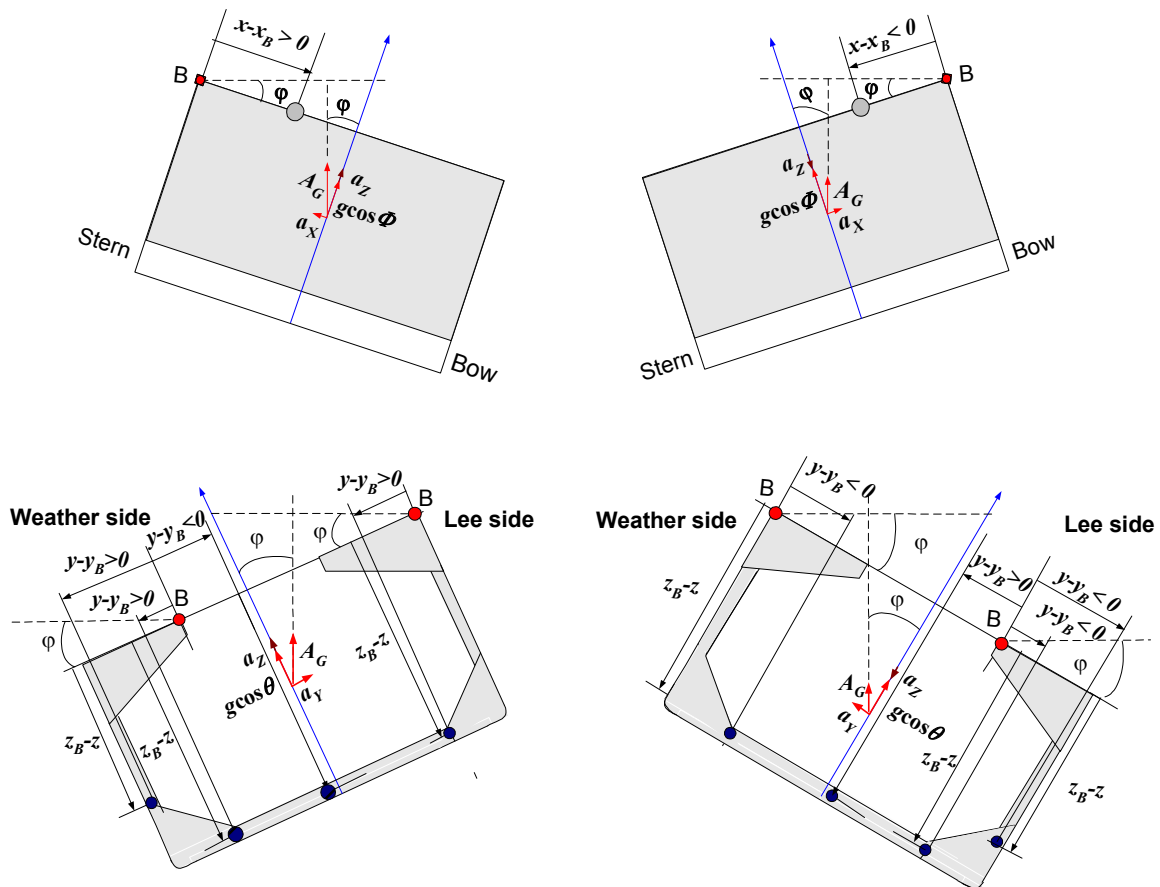

Fig. 3  
Definition of  $x_B$  and  $y_B$

### 3 Lateral pressures and forces in flooded condition

#### 3.1 Application

##### 3.1.1

The lateral pressures to be considered in flooded condition are indicated in:

- [3.2] in general cases
- [3.3] for the particular case of transverse corrugated bulkheads
- [3.4] for the particular case of double bottom

#### 3.2 General

##### 3.2.1

The pressure  $p_F$  to be considered as acting on plating (excluding bottom and side shell plating) which constitute boundaries of compartments not intended to carry liquids is to be obtained, in kN/m<sup>2</sup>, from the following formula:

$$p_F = \rho g \left( 1 + 0.6 \frac{a_z}{g} \right) (z_F - z),$$

without being less than  $gd_0$

where:

$z_F$  = Z co-ordinate, in m, of the freeboard deck at side in way of the transverse section considered. Where the results of damage stability calculations are available, the deepest equilibrium waterline may be considered in lieu of the freeboard deck; in this case, the Society may require transient conditions to be taken into account

$d_0$  = Distance, in m, to be taken equal to:  
 $d_0 = 0.02L$  for  $90 \text{ m} \leq L < 120 \text{ m}$   
 $d_0 = 2.4$  for  $L \geq 120 \text{ m}$

### 3.3 Transverse vertically corrugated watertight bulkheads

#### 3.3.1 Application

Each cargo hold is to be considered individually flooded.

#### 3.3.2 General

The loads to be considered as acting on each bulkhead are those given by the combination of those induced by cargo loads with those induced by the flooding of one hold adjacent to the bulkhead under examination. In any case, the pressure due to the flooding water alone is to be considered.

The most severe combinations of cargo induced loads and flooding loads are to be used for the check of the scantlings of each bulkhead, depending on the loading conditions included in the loading manual:

- homogeneous loading conditions
- non-homogeneous loading conditions,

considering the individual flooding of both loaded and empty holds.

For the purpose of this item, homogeneous loading condition means a loading condition in which the ratio between the highest and the lowest filling ratio, evaluated for each hold, does not exceed 1.20, to be corrected for different cargo densities.

Non-homogeneous part loading conditions associated with multiport loading and unloading operations for homogeneous loading conditions need not be considered according to these requirements.

The specified design load limits for the cargo holds are to be represented by loading conditions defined by the Designer in the loading manual.

For the purpose of this item, holds carrying packed cargoes are to be considered as empty.

Unless the ship is intended to carry, in non-homogeneous conditions, only iron ore or cargo having bulk density equal to or greater than  $1.78 \text{ t/m}^3$ , the maximum mass of cargo which may be carried in the hold is also to be considered to fill that hold up to the upper deck level at centreline.

#### 3.3.3 Flooding level

The flooding level  $z_F$  is the distance, in m, measured vertically from the base line with the ship in the upright position, and equal to:

- in general:
  - $D_1$  for the foremost transverse corrugated bulkhead
  - $0.9D_1$  for other bulkheads;

where the ship is to carry cargoes having bulk density less than  $1.78 \text{ t/m}^3$  in non-homogeneous loading conditions, the following values may be assumed:

- $0.95D_1$  for the foremost transverse corrugated bulkhead
- $0.85D_1$  for other bulkheads
- for ships less than 50000 t deadweight with type B freeboard:
- $0.95D_1$  for the foremost transverse corrugated bulkhead
- $0.85D_1$  for other bulkheads;

where the ship is to carry cargoes having bulk density less than  $1.78 \text{ t/m}^3$  in non-homogeneous loading conditions, the following values may be assumed:

- $0.9D_1$  for the foremost transverse corrugated bulkhead
- $0.8D_1$  for other bulkheads.

#### 3.3.4 Pressures and forces on a corrugation in non-flooded bulk cargo loaded holds

At each point of the bulkhead, the pressure is to be obtained, in  $\text{kN/m}^2$ , from the following formula:

$$p_B = \rho_C g (h_C + h_{DB} - z) \tan^2 \left( 45 - \frac{\psi}{2} \right)$$

The force acting on a corrugation is to be obtained, in kN, from the following formula:

$$F_B = \rho_C g s_C \frac{(h_C - h_{LS})^2}{2} \tan^2 \left( 45 - \frac{\psi}{2} \right)$$

### 3.3.5 Pressures and forces on a corrugation in flooded bulk cargo loaded holds

Two cases are to be considered, depending on the values of  $z_F$  and  $h_C$  (see [3.3.3] and [1.1]):

— First case, when  $z_F \geq h_C + h_{DB}$

At each point of the bulkhead located at a distance between  $z_F$  and  $h_C + h_{DB}$  from the base line, the pressure, in kN/m<sup>2</sup>, is to be obtained from the following formula:

$$p_{B,F} = \rho g (z_F - z)$$

At each point of the bulkhead located at a distance lower than  $h_C + h_{DB}$  from the base line, the pressure, in kN/m<sup>2</sup>, is to be obtained from the following formula:

$$p_{B,F} = \rho g (z_F - z) + [\rho_C - \rho(1 - perm)] g (h_C + h_{DB} - z) \tan^2 \left( 45 - \frac{\psi}{2} \right)$$

where *perm* is the permeability of cargo, to be taken as 0.3 for iron ore, coal cargoes and cement.

The force acting on a corrugation is to be obtained, in kN, from the following formula:

$$F_{B,F} = s_C \left[ \rho g \frac{(z_F - h_C - h_{DB})^2}{2} + \frac{\rho g (z_F - h_C - h_{DB}) + (p_{B,F})_{LE}}{2} (h_C - h_{LS}) \right]$$

where  $(p_{B,F})_{LE}$  is the pressure  $p_{B,F}$ , in kN/m<sup>2</sup>, calculated at the lower edge of the corrugation.

— Second case, when  $z_F < h_C + h_{DB}$

At each point of the bulkhead located at a distance between  $z_F$  and  $h_C + h_{DB}$  from the base line, the pressure is to be obtained, in kN/m<sup>2</sup>, from the following formula:

$$p_{B,F} = \rho_C g (h_C + h_{DB} - z) \tan^2 \left( 45 - \frac{\psi}{2} \right)$$

At each point of the bulkhead located at a distance lower than  $z_F$  from the base line, the pressure is to be obtained, in kN/m<sup>2</sup>, from the following formula:

$$p_{B,F} = \rho g (z_F - z) + [\rho_C (h_C + h_{DB} - z) - \rho(1 - perm)(z_F - z)] g \tan^2 \left( 45 - \frac{\psi}{2} \right)$$

where *perm* is the permeability of cargo, to be taken as 0.3 for iron ore, coal cargoes and cement.

The force acting on a corrugation is to be obtained, in kN, from the following formula:

$$F_{B,F} = s_C \left[ \rho_C g \frac{(h_C + h_{DB} - z_F)^2}{2} \tan^2 \left( 45 - \frac{\psi}{2} \right) \right] + s_C \left[ \frac{\rho_C g (h_C + h_{DB} - z_F) \tan^2 \left( 45 - \frac{\psi}{2} \right) + (p_{B,F})_{LE}}{2} (z_F - h_{DB} - h_{LS}) \right]$$

where  $(p_{B,F})_{LE}$  is the pressure  $p_{B,F}$ , in kN/m<sup>2</sup>, calculated at the lower edge of the corrugation.

### 3.3.6 Pressures and forces on a corrugation in flooded empty holds

At each point of the bulkhead, the still water pressure induced by the flooding to be considered is to be obtained, in kN/m<sup>2</sup>, from the following formula:

$$p_F = \rho g (z_F - z)$$

The force acting on a corrugation is to be obtained, in kN, from the following formula:

$$F_F = s_C \rho g \frac{(z_F - h_{DB} - h_{LS})^2}{2}$$

### 3.3.7 Resultant pressures and forces

Resultant pressures and forces to be calculated for homogeneous and non-homogeneous loading conditions are to be obtained according to the following formulae:

— Homogeneous loading conditions

At each point of the bulkhead structures, the resultant pressure to be considered for the scantlings of the bulkhead is to be obtained, in  $\text{kN/m}^2$ , from the following formula:

$$p = p_{B,F} - 0.8p_B$$

The resultant force acting on a corrugation is to be obtained, in kN, from the following formula:

$$F = F_{B,F} - 0.8 F_B$$

where:

- $p_B$  = Pressure in the non-flooded holds, in  $\text{kN/m}^2$ , to be obtained as specified in [3.3.4]
- $p_{B,F}$  = Pressure in the flooded holds, in  $\text{kN/m}^2$ , to be obtained as specified in [3.3.5]
- $F_{B,F}$  = Force acting on a corrugation in the flooded holds, in kN, to be obtained as specified in [3.3.5].
- $F_B$  = Force acting on a corrugation in non-flooded holds, in kN, to be obtained as specified in [3.3.4].

— Non-homogeneous loading conditions

At each point of the bulkhead structures, the resultant pressure to be considered for the scantlings of the bulkhead is to be obtained, in  $\text{kN/m}^2$ , by the following formula:

$$P = p_{B,F}$$

The resultant force acting on a corrugation is to be obtained, in kN, by the following formula:

$$F = F_{B,F}$$

where:

- $p_{B,F}$  = Pressure in the flooded holds  $\text{kN/m}^2$ , to be obtained as specified in [3.3.5]
- $F_{B,F}$  = Force acting on a corrugation in the flooded holds  $\text{kN/m}^2$ , to be obtained as specified in [3.3.5].

### 3.4 Double bottom

#### 3.4.1 Application

Each cargo hold is to be considered individually flooded.

#### 3.4.2 General

The loads to be considered as acting on the double bottom are those given by the external sea pressures and the combination of the cargo loads with those induced by the flooding of the hold which the double bottom belongs to.

The most severe combinations of cargo induced loads and flooding loads are to be used, depending on the loading conditions included in the loading manual:

- homogeneous loading conditions
- non-homogeneous loading conditions
- packed cargo conditions (such as in the case of steel mill products).

For each loading condition, the maximum dry bulk cargo density to be carried is to be considered in calculating the allowable hold loading.

#### 3.4.3 Flooding level

The flooding level  $z_F$  is the distance, in m, measured vertically from the base line with the ship in the upright position, and equal to:

- for ships less than 50000 t deadweight with type B freeboard:
  - $0.95D_1$  for the foremost hold
  - $0.85D_1$  for other holds.
- for other ships:
  - $D_1$  for the foremost hold
  - $0.9D_1$  for other holds.

## 4 Testing lateral pressure

### 4.1 Still water pressures

#### 4.1.1

The total pressure to be considered as acting on plates and stiffeners subject to tank testing is obtained, in kN/m<sup>2</sup>, from the following formula:

$$p_{ST} = 10(z_{ST} - z)$$

where:

$z_{ST}$  = Testing load height, in m, as defined in Table 2.

<b>Table 2 Testing load height</b>	
<i>Compartment or structure to be tested</i>	<i>Testing load height, in m</i>
Double bottom tanks	The greater of the following: $z_{ST} = z_{TOP} + d_{AP}$ $z_{ST} = z_{ml}$
Hopper side tanks, topside tanks, double side tanks, fore and after peaks used as tank, cofferdams	The greater of the following: $z_{ST} = z_{TOP} + d_{AP}$ $z_{ST} = z_{TOP} + 2.4$
Tank bulkheads, deep tanks, fuel oil bunkers	The greater of the following: $z_{ST} = z_{TOP} + d_{AP}$ $z_{ST} = z_{TOP} + 2.4$ $z_{ST} = z_{TOP} + 10p_{PV}$
Ballast hold	The greater of the following: $z_{ST} = z_{TOP} + d_{AP}$ $z_{ST} = z_h + 0.9$
Fore and aft peak not used as tank	The greater of the following: $z_{ST} = z_F$ $z_{ST} = z_{ml}$
Watertight doors below freeboard deck	$z_{ST} = z_{fd}$
Chain locker (if aft of collision bulkhead)	$z_{ST} = z_{TOP}$
Independent tanks	The greater of the following: $z_{ST} = z_{TOP} + d_{AP}$ $z_{ST} = z_{TOP} + 0.9$
Ballast ducts	Testing load height corresponding to ballast pump maximum pressure
<p>where:</p> <p><math>z_{ml}</math> = Z co-ordinate, in m, of the margin line.  <math>z_h</math> = Z co-ordinate, in m, of the top of hatch.  <math>z_F</math> = As defined in [3.2.1].  <math>z_{fd}</math> = Z co-ordinate, in m, of the freeboard deck.  <math>p_{PV}</math> = Setting pressure, in bar, of safety valves.</p>	

## SECTION 7 LOADING CONDITIONS

### Symbols

$M_H$  = The actual cargo mass in a cargo hold corresponding to a homogeneously loaded condition at maximum draught, in t

$M_{Full}$  = The cargo mass in a cargo hold corresponding to cargo with virtual density (homogenous mass / hold cubic capacity, minimum 1.0 t/m<sup>3</sup>) filled to the top of the hatch coaming, in t.

$$M_{Full} = V_{Full} \cdot \max(M_H / V_H, 1.0)$$

$M_{HD}$  = The maximum cargo mass allowed to be carried in a cargo hold according to design loading condition(s) with specified holds empty at maximum draught, in t  
*M<sub>Full</sub>* is in no case to be less than *M<sub>H</sub>*

$V_{Full}$  = Volume, in m<sup>3</sup>, of the cargo hold including the volume enclosed by the hatch coaming

$V_H$  = Volume, in m<sup>3</sup>, defined in Ch 4, Sec 6

$T_{HB}$  = Deepest ballast draught, in m.

### 1 Application

#### 1.1 Ships having a length L less than 150 m

##### 1.1.1

The severest loading conditions from the loading manual, midship section drawing or otherwise specified by the Designer are to be considered for the longitudinal strength according to Ch 5, Sec 1 and for the local strength check of plating, ordinary stiffeners and primary supporting members according to Ch 6.

#### 1.2 Ships having a length L of 150 m and above

##### 1.2.1

The requirements in [2] to [4] are applicable to ships having a length *L* of 150 m and above.

##### 1.2.2

These requirements are not intended to prevent any other loading conditions to be included in the loading manual for which calculations are to be submitted. It is not intended to replace in any way the required loading manual/instrument.

##### 1.2.3

The maximum loading condition draught is to be taken as the moulded summer load line draught.

##### 1.2.4

The loading conditions listed in [2] are to be applied for the check of longitudinal strength as required by Ch 5, Sec 1, the check of local strength by Ch 6, the direct strength analysis by Ch 7, for capacity and disposition of ballast tanks and stability purposes. The loading conditions listed in [3] are to be applied for the check of local strength. The loading conditions listed in [4] are to be applied for direct strength analysis.

##### 1.2.5

In operation, a bulk carrier may be loaded differently from the design loading conditions specified in the loading manual, provided longitudinal and local strength as defined in the loading manual and onboard loading instrument and applicable stability requirements are not exceeded.



## 2 General

### 2.1 Design loading conditions - General

#### 2.1.1

For the determination of the maximum cargo mass in cargo holds, the condition corresponding to the ship being loaded at maximum draught with 50% of consumables is to be considered.

#### 2.1.2 BC-C

Homogeneous cargo loaded condition where the cargo density corresponds to all cargo holds, including hatchways, being 100% full at maximum draught with all ballast tanks empty.

#### 2.1.3 BC-B

As required for **BC-C**, plus:

Homogeneous cargo loaded condition with cargo density  $3.0 \text{ t/m}^3$ , and the same filling ratio (cargo mass/hold cubic capacity) in all cargo holds at maximum draught with all ballast tanks empty.

In cases where the cargo density applied for this design loading condition is less than  $3.0 \text{ t/m}^3$ , the maximum density of the cargo that the ship is allowed to carry is to be indicated with the additional service feature **{maximum cargo density  $x.y \text{ t/m}^3$ }**.

#### 2.1.4 BC-A

As required for **BC-B**, plus:

At least one cargo loaded condition with specified holds empty, with cargo density  $3.0 \text{ t/m}^3$ , and the same filling ratio (cargo mass/hold cubic capacity) in all loaded cargo holds at maximum draught with all ballast tanks empty.

The combination of specified empty holds is to be indicated with the additional service feature **{holds  $a, b, \dots$  may be empty}**.

In such cases where the design cargo density applied is less than  $3.0 \text{ t/m}^3$ , the maximum density of the cargo that the ship is allowed to carry is to be indicated within the additional service feature **{holds  $a, b, \dots$  may be empty with maximum cargo density  $x.y \text{ t/m}^3$ }**.

### 2.2 Applicable ballast conditions

#### 2.2.1 Ballast tank capacity and disposition

All bulk carriers are to have ballast tanks of sufficient capacity and so disposed to at least fulfill the following requirements.

Normal ballast condition

Normal ballast condition is a ballast (no cargo) condition where:

- the ballast tanks may be full, partially full or empty. Where ballast tanks are partially full, the conditions in Ch 4, Sec 3 are to be complied with
- any cargo hold or holds adapted for the carriage of water ballast at sea are to be empty
- the propeller is to be fully immersed, and
- the trim is to be by the stern and is not to exceed  $0.015L_{BP}$ .

In the assessment of the propeller immersion and trim, the draughts at the forward and after perpendiculars may be used.

#### Heavy ballast condition

Heavy ballast condition is a ballast (no cargo) condition where:

- the ballast tanks may be full, partially full or empty. Where ballast tanks are partially full, the conditions in Ch 4, Sec 3 are to be complied with
- at least one cargo hold adapted for carriage of water ballast at sea is to be full
- the propeller immersion  $I/D$  is to be at least 60 %, where:  
 $I$  = Distance from propeller centerline to the waterline  
 $D$  = Propeller diameter
- the trim is to be by the stern and is not to exceed  $0.015L_{BP}$
- the moulded forward draught in the heavy ballast condition is not to be less than the smaller of  $0.03L_{BP}$  or 8 m.

### 2.2.2 Strength requirements

All bulk carriers are to meet the following strength requirements:

#### Normal ballast condition:

- the structures of bottom forward are to be strengthened in accordance with the Rules against slamming for the condition of [2.2.1] for normal ballast condition at the lightest forward draught,
- the longitudinal strength requirements according to Ch 4, Sec 3 are to be met for the condition of [2.2.1] for normal ballast condition, and
- in addition, the longitudinal strength requirements according to Ch 4, Sec 3 are to be met with all ballast tanks 100% full.

#### Heavy ballast condition:

- the longitudinal strength requirements according to Ch 4, Sec 3 are to be met for the condition of [2.2.1] for heavy ballast condition
- in addition, the longitudinal strength requirements according to Ch 4, Sec 3 are to be met with all ballast tanks 100% full and one cargo hold adapted and designated for the carriage of water ballast at sea, where provided, 100% full, and
- where more than one hold is adapted and designated for the carriage of water ballast at sea, it will not be required that two or more holds be assumed 100% full simultaneously in the longitudinal strength assessment, unless such conditions are expected in the heavy ballast condition. Unless each hold is individually investigated, the designated heavy ballast hold and any/all restrictions for the use of other ballast hold(s) are to be indicated in the loading manual.

## 2.3 Departure and arrival conditions

### 2.3.1

Unless otherwise specified, each of the design loading conditions defined in [2.1] and [2.2] is to be investigated for the arrival and departure conditions as defined as follows:

Departure condition: with bunker tanks not less than 95% full and other consumables 100%

Arrival condition: with 10% of consumables

## 3 Design loading conditions for local strength

### 3.1 Definitions

#### 3.1.1

The maximum allowable or minimum required cargo mass in a cargo hold, or in two adjacently loaded holds, is related to the net load on the double bottom. The net load on the double bottom is a function of draft, cargo mass in the cargo hold, as well as the mass of fuel oil and ballast water contained in double bottom tanks.

### 3.2 Applicable general conditions

#### 3.2.1

Any cargo hold is to be capable of carrying  $M_{Full}$  with fuel oil tanks in double bottom in way of the cargo hold, if any, being 100% full and ballast water tanks in the double bottom in way of the cargo hold being empty, at maximum draught.

#### 3.2.2

Any cargo hold is to be capable of carrying minimum 50% of  $M_H$ , with all double bottom tanks in way of the cargo hold being empty, at maximum draught.

#### 3.2.3

Any cargo hold is to be capable of being empty, with all double bottom tanks in way of the cargo hold being empty, at the deepest ballast draught.

### **3.3 Additional conditions applicable except when additional service feature {no MP} is assigned**

#### **3.3.1**

Any cargo hold is to be capable of carrying  $M_{Full}$  with fuel oil tanks in double bottom in way of the cargo hold, if any, being 100% full and ballast water tanks in the double bottom in way of the cargo hold being empty, at 67% of maximum draught.

#### **3.3.2**

Any cargo hold is to be capable of being empty with all double bottom tanks in way of the cargo hold being empty, at 83% of maximum draught.

#### **3.3.3**

Any two adjacent cargo holds are to be capable of carrying  $M_{Full}$  with fuel oil tanks in double bottom in way of the cargo hold, if any, being 100% full and ballast water tanks in the double bottom in way of the cargo hold being empty, at 67% of the maximum draught. This requirement to the mass of cargo and fuel oil in double bottom tanks in way of the cargo hold applies also to the condition where the adjacent hold is filled with ballast, if applicable.

#### **3.3.4**

Any two adjacent cargo holds are to be capable of being empty, with all double bottom tanks in way of the cargo hold being empty, at 75% of maximum draught.

### **3.4 Additional conditions applicable for BC-A only**

#### **3.4.1**

Cargo holds, which are intended to be empty at maximum draught, are to be capable of being empty with all double bottom tanks in way of the cargo hold also being empty.

#### **3.4.2**

Cargo holds, which are intended to be loaded with high density cargo, are to be capable of carrying  $M_{HD}$  plus 10% of  $M_H$ , with fuel oil tanks in the double bottom in way of the cargo hold, if any, being 100% full and ballast water tanks in the double bottom being empty in way of the cargo hold, at maximum draught.

In operation the maximum allowable cargo mass shall be limited to  $M_{HD}$ .

#### **3.4.3**

Any two adjacent cargo holds which according to a design loading condition may be loaded with the next holds being empty, are to be capable of carrying 10% of  $M_H$  in each hold in addition to the maximum cargo load according to that design loading condition, with fuel oil tanks in the double bottom in way of the cargo hold, if any, being 100% full and ballast water tanks in the double bottom in way of the cargo hold being empty, at maximum draught.

In operation the maximum allowable mass shall be limited to the maximum cargo load according to the design loading conditions.

### **3.5 Additional conditions applicable for ballast hold(s) only**

#### **3.5.1**

Cargo holds, which are designed as ballast water holds, are to be capable of being 100% full of ballast water including hatchways, with all double bottom tanks in way of the cargo hold being 100% full, at any heavy ballast draught. For ballast holds adjacent to topside wing, hopper and double bottom tanks, it shall be strengthwise acceptable that the ballast holds are filled when the topside wing, hopper and double bottom tanks are empty.

### **3.6 Additional conditions applicable during loading and unloading in harbour only**

#### **3.6.1**

Any single cargo hold is to be capable of holding the maximum allowable seagoing mass at 67% of maximum draught, in harbour condition.

#### **3.6.2**

Any two adjacent cargo holds are to be capable of carrying  $M_{Full}$ , with fuel oil tanks in the double bottom in

way of the cargo hold, if any, being 100% full and ballast water tanks in the double bottom in way of the cargo hold being empty, at 67% of maximum draught, in harbour condition.

### 3.6.3

At reduced draught during loading and unloading in harbour, the maximum allowable mass in a cargo hold may be increased by 15% of the maximum mass allowed at the maximum draught in sea-going condition, but shall not exceed the mass allowed at maximum draught in the sea-going condition. The minimum required mass may be reduced by the same amount.

## 3.7 Hold mass curves

### 3.7.1

Based on the design loading criteria for local strength, as given in [3.2] to [3.6] except [3.5.1], hold mass curves are to be included in the loading manual and the loading instrument, showing maximum allowable and minimum required mass as a function of draught in sea-going condition as well as during loading and unloading in harbour. Hold mass curves are to be calculated according to Ch 4, App 1.

### 3.7.2

At other draughts than those specified in the design loading conditions, the maximum allowable and minimum required mass is to be adjusted for the change in buoyancy acting on the bottom. Change in buoyancy is to be calculated using water plane area at each draught.

Hold mass curves for each single hold, as well as for any two adjacent holds, are to be included in the loading manual and the loading instrument.

## 4 Design loading conditions for direct strength analysis

### 4.1 Loading patterns

#### 4.1.1

The loading patterns applicable to types of bulk carriers with various service feature notations are summarized in Table 1, which are to be considered in direct strength analysis in accordance with [2] and [3].

No.	Loading pattern	Ref.	BC-			BC-, (no MP)		
			A	B	C	A	B	C
1	Full load in homogeneous condition	3.2.1	x	x	x	x	x	x
2	Slack load	3.2.2	x	x	x	x	x	x
3	Deepest ballast	3.2.3	x	x	x	x	x	x
4	Multiport -1	3.3.1	x	x	x			
5	Multiport -2	3.3.2	x	x	x			
6	Multiport -3	3.3.3	x	x	x			
7	Multiport -4	3.3.4	x	x	x			
8	Alternate load	3.4.1&.2	x			x		
9	Alternate block load	3.4.3	x			x		
10	Heavy ballast	3.5.1	x	x	x	x	x	x
11	Harbour condition -1	3.6.1				x	x	x
12	Harbour condition -2	3.6.2				x	x	x

#### 4.1.2

Other loading conditions from the loading manual, which are not covered in Table 1, if any, are also to be considered.

## 4.2 Still water bending moment and shear force

### 4.2.1

Load cases defined in Sec 4 are to be considered for each loading pattern given in Table 1. The still water vertical bending moment provided in Table 2 and the still water vertical shear force provided in Table 3 are to be used for each combination of loading pattern and load case.

### 4.2.2

If one loading condition in the loading manual has a still water vertical bending moment more severe than the value in Table 2 for the corresponding loading pattern, the value in Table 2 for this loading pattern is to be replaced with the value from the loading manual.

## 4.3 Application

### 4.3.1

The minimum required loading conditions for direct strength analysis, including vertical shear force analysis, are defined in Ch 4, App 2.

### 4.3.2

The standard loading conditions for fatigue assessment are defined in Ch 4, App 3.

		Loading pattern					Harbour condition
		Full load in homogeneous condition	Slack load	Multiport		Heavy ballast (Ballast hold)	
			Alternate load	Alternate block load			
Normal ballast	Deepest ballast						
Load case	H1	$0.5M_{SW,S}$	0	$M_{SW,S}$		$M_{SW,S}$	---
	H2	$0.5M_{SW,H}$	$M_{SW,H}$	$M_{SW,H}$		0	
	F1	$0.5 M_{SW,S}$	0	$M_{SW,S}$		$M_{SW,S}$	
	F2	$0.5M_{SW,H}$	$M_{SW,H}$	$M_{SW,H}$		0	
	R1	$0.5 M_{SW,S}$	0	$M_{SW,S}$		$M_{SW,S}$	
		$0.5M_{SW,H}$	$M_{SW,H}$	$M_{SW,H}$		0	
	R2	$0.5 M_{SW,S}$	0	$M_{SW,S}$		$M_{SW,S}$	
		$0.5M_{SW,H}$	$M_{SW,H}$	$M_{SW,H}$		0	
	P1	$0.5 M_{SW,S}$	0	$M_{SW,S}$		$M_{SW,S}$	
	P2	$0.5M_{SW,H}$	$M_{SW,H}$	$M_{SW,H}$		0	
Static	---					$M_{SW,P,S}$	
						$M_{SW,P,H}$	

where:

$M_{SW,H}$  = Allowable still water vertical bending moment in hogging condition for seagoing condition

$M_{SW,S}$  = Allowable still water vertical bending moment in sagging condition for seagoing condition

$M_{SW,P,H}$  = Allowable still water vertical bending moment in hogging condition for harbour condition

$M_{SW,P,S}$  = Allowable still water vertical bending moment in sagging condition for harbour condition

		Loading pattern				
		Full load in homogeneous condition	Alternate load (BC-A)	Multiport (BC-B and BC-C)	Heavy ballast (Ballast hold)	Heavy ballast (Except for ballast hold)
Load case	H1	---	$Q_{SW}$	$Q_{SW}$	$Q_{SW}$	---
	H2	---	$Q_{SW}$	$Q_{SW}$	$Q_{SW}$	---
	F1	---	$Q_{SW}$	$Q_{SW}$	$Q_{SW}$	---
	F2	---	$Q_{SW}$	$Q_{SW}$	$Q_{SW}$	---

where:

$Q_{SW}$  = Allowable still water shear force at the position of the considered transverse bulkhead

## SECTION 8 LOADING MANUAL AND LOADING INSTRUMENT

### 1 General

#### 1.1 All ships

##### 1.1.1

An approved loading manual is to be supplied on board for all ships.

In addition, an approved loading instrument is to be supplied for all ships.

The loading instrument is ship specific onboard equipment and the results of the calculations are only applicable to the ship for which it has been approved.

An approved loading instrument may not replace an approved loading manual.

#### 1.2 Ships equal to or greater than 150 m in length L

##### 1.2.1

**BC-A**, **BC-B**, and **BC-C** ships are to be provided with an approved loading manual and an approved computer-based loading instrument, in accordance with the applicable requirements of this Section.

A guidance for loading and unloading sequences is given in [5].

### 2 Loading manual

#### 2.1 Definitions

##### 2.1.1 All ships

A loading manual is a document which describes:

- the loading conditions on which the design of the ship has been based, including permissible limits of still water bending moment and shear force. The conditions specified in the ballast water exchanging procedure and dry docking procedure are to be included in the loading manual.
- the results of the calculations of still water bending moments and shear forces
- the allowable local loading for the structure (hatch covers, decks, double bottom, etc.).

##### 2.1.2 Ships equal to or greater than 150 m in length L

In addition to [2.1.1], for **BC-A**, **BC-B** and **BC-C** ships, the loading manual is also to describe:

- envelope results and permissible limits of still water bending moments and shear forces in the hold flooded condition according to Ch 5, Sec 1
- the cargo hold(s) or combination of cargo holds that might be empty at full draught. If no cargo hold is allowed to be empty at full draught, this is to be clearly stated in the loading manual
- maximum allowable and minimum required mass of cargo and double bottom contents of each hold as a function of the draught at mid-hold position
- maximum allowable and minimum required mass of cargo and double bottom contents of any two adjacent holds as a function of the mean draught in way of these holds. This mean draught may be calculated by averaging the draught of the two mid-hold positions
- maximum allowable tank top loading together with specification of the nature of the cargo for cargoes other than bulk cargoes
- maximum allowable load on deck and hatch covers. If the ship is not approved to carry load on deck or hatch covers, this is to be clearly stated in the loading manual
- maximum rate of ballast change together with the advice that a load plan is to be agreed with the terminal on the basis of the achievable rates of change of ballast.

#### 2.2 Conditions of approval

##### 2.2.1 All ships

The approved loading manual is to be based on the final data of the ship. The manual is to include the design (cargo and ballast) loading conditions, subdivided into departure and arrival conditions as appropriate, upon

which the approval of the hull scantlings is based.

In the case of modifications resulting in changes to the main data of the ship, a new approved loading manual is to be issued.

### 2.2.2 Ships equal to or greater than 150 m in length L

In addition to [2.2.1], for **BC-A**, **BC-B** and **BC-C** ships, the following loading conditions, subdivided into departure and arrival conditions as appropriate, are also to be included in the loading manual:

- homogeneous light and heavy cargo loading conditions at maximum draught
- alternate light and heavy cargo loading conditions at maximum draught, where applicable
- ballast conditions. For ships having ballast holds adjacent to topside wing, hopper and double bottom tanks, it shall be strengthwise acceptable that the ballast holds are filled when the topside wing, hopper and double bottom tanks are empty
- short voyage conditions where the ship is to be loaded to maximum draught but with limited amount of bunkers
- multiple port loading / unloading conditions
- deck cargo conditions, where applicable
- typical loading sequences where the ship is loaded from commencement of cargo loading to reaching full deadweight capacity, for homogeneous conditions, relevant part load conditions and alternate conditions where applicable. Typical unloading sequences for these conditions are also to be included. The typical loading / unloading sequences are also to be developed to not exceed applicable strength limitations. The typical loading sequences are also to be developed paying due attention to loading rate and the deballasting capability. Table 1 contains, as guidance only, an example of a Loading Sequence Summary Form
- typical sequences for change of ballast at sea, where applicable.

## 2.3 Language

### 2.3.1

The loading manual is to be prepared in a language understood by the users. If this language is not English, a translation into English is to be included.

## 3 Loading instrument

### 3.1 Definitions

#### 3.1.1 All ships

A loading instrument is an instrument which is either analog or digital and by means of which it can be easily and quickly ascertained that, at specified read-out points, the still water bending moments, shear forces, in any load or ballast condition, do not exceed the specified permissible values.

#### 3.1.2 Ships equal to or greater than 150 m in length L

For **BC-A**, **BC-B** and **BC-C** ships, the loading instrument is an approved digital system as defined in [3.1.1]. In addition to [3.1.1], it is also to ascertain as applicable that:

- the mass of cargo and double bottom contents in way of each hold as a function of the draught at mid-hold position
- the mass of cargo and double bottom contents of any two adjacent holds as a function of the mean draught in way of these holds
- the still water bending moment and shear forces in the hold flooded conditions

do not exceed the specified permissible values.

### 3.2 Conditions of approval

#### 3.2.1 All ships

The loading instrument is subject to approval, which is to include:

- verification of type approval, if any
- verification that the final data of the ship have been used
- acceptance of number and position of all read-out points
- acceptance of relevant limits for read-out points

- checking of proper installation and operation of the instrument on board, under agreed test conditions, and that a copy of the operation manual is available.

### **3.2.2 Ships equal to or greater than 150 m in length L**

In addition, for **BC-A**, **BC-B** and **BC-C** ships, the approval is also to include, as applicable:

- acceptance of hull girder bending moment limits for all read-out points
- acceptance of hull girder shear force limits for all read-out points
- acceptance of limits for the mass of cargo and double bottom contents of each hold as a function of draught
- acceptance of limits for the mass of cargo and double bottom contents in any two adjacent holds as a function of draught.

### **3.2.3**

In the case of modifications implying changes in the main data of the ship, the loading instrument is to be modified accordingly and approved.

### **3.2.4**

An operational manual is always to be provided for the loading instrument.

The operation manual and the instrument output are to be prepared in a language understood by the users. If this language is not English, a translation into English is to be included.

### **3.2.5**

The operation of the loading instrument is to be verified upon installation under the agreed test conditions. It is to be checked that the agreed test conditions and the operation manual for the instrument are available on board.

## **4 Annual and class renewal survey**

### **4.1 General**

#### **4.1.1**

At each annual and class renewal survey, it is to be checked that the approved loading manual is available on board.

#### **4.1.2**

The loading instrument is to be checked for accuracy at regular intervals by the ship's Master by applying test loading conditions.

#### **4.1.3**

At each class renewal survey this checking is to be done in the presence of the Surveyor.

## **5 Guidance for loading/unloading sequences**

### **5.1 General**

#### **5.1.1**

The typical loading/unloading sequences shall be developed paying due attention to the loading/unloading rate, the ballasting/deballasting capacity and the applicable strength limitations.

#### **5.1.2**

The shipbuilder will be required to prepare and submit for approval typical loading and unloading sequences.

#### **5.1.3**

The typical loading sequences as relevant should include:

- alternate light and heavy cargo load condition
- homogeneous light and heavy cargo load condition



- short voyage condition where the ship is loaded to maximum draught but with limited bunkers
- multiple port loading/unloading condition
- deck cargo condition
- block loading.

#### **5.1.4**

The loading/unloading sequences may be port specific or typical.

#### **5.1.5**

The sequence is to be built up step by step from commencement of cargo loading to reaching full deadweight capacity. Each time the loading equipment changes position to a new hold defines a step. Each step is to be documented and submitted to the Society. In addition to longitudinal strength, the local strength of each hold is to be considered.

#### **5.1.6**

For each loading condition a summary of all steps is to be included. This summary is to highlight the essential information for each step such as:

- how much cargo is filled in each hold during the different steps,
- how much ballast is discharged from each ballast tank during the different steps,
- the maximum still water bending moment and shear at the end of each step,
- the ship's trim and draught at the end of each step.

LOADING/UNLOADING SEQUENCE SUMMARY FORM

Vessel name	Voyage No.	Condition	Yard	Id. Number	
-------------	------------	-----------	------	------------	--

Hold No.	1	2	3	4	5	6	7
Volume of Hold, V (m <sup>3</sup> )							
Height of hold, h (m)							

Cargo mass Density (ton/m <sup>3</sup> ) Grade	Hold content at commencement of loading/discharging							Wings or peaks	
	Hold 1	Hold 2	Hold 3	Hold 4	Hold 5	Hold 6	Hold 7	Upper	Lower/Peak
1								Upper	Lower/Peak
2								Upper	Lower/Peak
3								Upper	Lower/Peak
4								Upper	Lower/Peak
5								Upper	Lower/Peak
6								Upper	Lower/Peak
7								Upper	Lower/Peak
8								Upper	Lower/Peak
Total amount of bunkers onboard (t):									
Draft Survey n-1									
Draft Survey n									

Cargo mass	Hold content at end of loading/discharging							Wings or peaks	
	Hold 1	Hold 2	Hold 3	Hold 4	Hold 5	Hold 6	Hold 7	Upper	Lower/Peak
Total mass loaded/discharged (t)								Upper	Lower/Peak
Total mass loaded/discharged (t):									

Net load on Double Bottom	Net load in two adjacent holds	Length/m <sup>2</sup>	Tons

Maximum occurring values among all conditions above.

Net load on double bottom =  $(MB/V) + h \cdot T / (Gm^3)$   
 where: MB = Mass in hold + mass in DB (t)  
 V = Total volume of hold (m<sup>3</sup>)  
 h = height of hold from lower bottom to top of coaming (m)  
 T = draught (m)

Approved by: \_\_\_\_\_ Date: \_\_\_\_\_

Table 1 Guidance on Typical Loading Sequence Summary Form

## APPENDIX 1 HOLD MASS CURVES

### Symbols

$h$	= Vertical distance from the top of inner bottom plating to upper deck plating at the ship's centreline, in m.
$h_a$	= Vertical distance from the top of inner bottom plating to the lowest point of the upper deck plating at the ship's centreline of the aft cargo hold in a block loading, in m.
$h_f$	= Vertical distance from the top of inner bottom plating to the lowest point of the upper deck plating at the ship's centreline of the fore cargo hold in a block loading, in m.
$M_H$	= As defined in Ch 4, Sec 7.
$M_{Full}$	= As defined in Ch 4, Sec 7.
$M_{HD}$	= As defined in Ch 4, Sec 7.
$M_D$	= The maximum cargo mass given for each cargo hold, in t.
$M_{BLK}$	= The maximum cargo mass in a cargo hold according to the block loading condition in the loading manual, in t.
$T_{HB}$	= As defined in Ch 4, Sec 7.
$T_i$	= Draught in loading condition No. $i$ , at mid-hold position of cargo hold length $\ell_H$ , in m
$V_H$	= As defined in Ch 4, Sec 6.
$V_f$ and $V_a$	= Volume of the forward and after cargo hold excluding volume of the hatchway part, in m <sup>3</sup> .
$T_{min}$	= $0.75T_S$ or draught in ballast conditions with the two adjacent cargo holds empty, whichever is greater, in m.
$\Sigma$	= The sum of masses of two adjacent cargo holds.

## 1 General

### 1.1 Application

#### 1.1.1

The requirements of this Appendix apply to ships of 150 m in length  $L$  and above.

#### 1.1.2

This Appendix describes the procedure to be used for determination of:

- the maximum and minimum mass of cargo in each cargo hold as a function of the draught at mid-hold position of cargo hold
- the maximum and minimum mass of cargo in any two adjacent holds as a function of the mean draught in way of these holds.

#### 1.1.3

Results of these calculations are to be included in the reviewed loading manual which has also to indicate the maximum permissible mass of cargo at scantling draught in each hold or in any two adjacent holds, as obtained from the design review.

#### 1.1.4

The following notice on referring to the maximum permissible and the minimum required mass of cargo is to be described in loading manual.

Where ship engages in a service to carry such hot coils or heavy cargoes that have some adverse effect on the local strength of the double bottom and that the loading is not described as cargo in loading manual, the maximum permissible and the minimum required mass of cargo are to be considered specially.

## 2 Maximum and minimum masses of cargo in each hold

### 2.1 Maximum permissible mass and minimum required masses of single cargo hold in seagoing condition

#### 2.1.1 General

The cargo mass curves of single cargo hold in seagoing condition are defined in [2.1.2] to [2.1.5]. However if the ship structure is checked for more severe loading conditions than the ones considered in Ch 4, Sec 7, [3.7.1], the minimum required cargo mass and the maximum allowable cargo mass can be based on those corresponding loading conditions.

#### 2.1.2 BC-A ship not having {No MP} assigned

— For loaded holds

The maximum permissible mass ( $W_{\max}(T_i)$ ) at various draughts ( $T_i$ ) is obtained, in t, by the following formulae:

$$W_{\max}(T_i) = M_{HD} + 0.1M_H - 1.025V_H \frac{(T_S - T_i)}{h}$$

However,  $W_{\max}(T_i)$  is no case to be greater than  $M_{HD}$ .

The minimum required cargo mass ( $W_{\min}(T_i)$ ) at various draughts ( $T_i$ ) is obtained, in t, by the following formulae:

$$W_{\min}(T_i) = 0 \text{ for } T_i \leq 0.83T_S$$

$$W_{\min}(T_i) = 1.025V_H \frac{(T_i - 0.83T_S)}{h}$$

for

$$T_S \geq T_i > 0.83T_S$$

— For empty holds which can be empty at the maximum draught

The maximum permissible mass ( $W_{\max}(T_i)$ ) at various draughts ( $T_i$ ) is obtained, in t, by the following formulae:

$$W_{\max}(T_i) = M_{Full} \text{ for } T_S \geq T_i \geq 0.67T_S$$

$$W_{\max}(T_i) = M_{Full} - 1.025V_H \frac{(0.67T_S - T_i)}{h} \text{ for } T_i < 0.67T_S$$

The minimum required mass ( $W_{\min}(T_i)$ ) is obtained, in t, by the following formula:

$$W_{\min}(T_i) = 0 \text{ for } T_i \leq T_S$$

Examples for mass curve of loaded cargo hold and cargo hold which can be empty at the maximum draught for **BC-A** ships not having {No MP} assigned are shown in Fig 1.

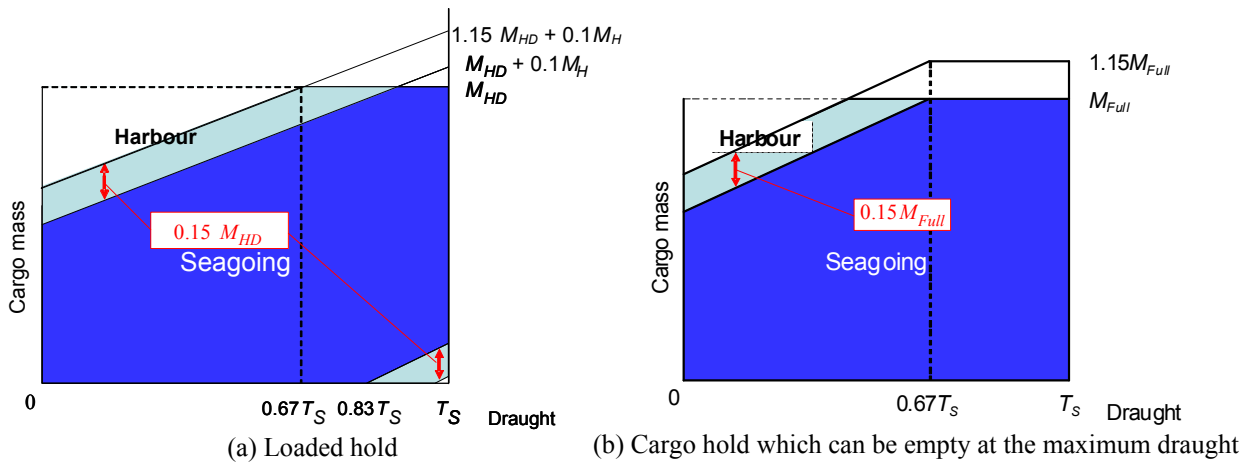

Fig. 1  
Example of mass curve for **BC-A** ships not having {No MP} assigned

### 2.1.3 BC-A ship having {No MP} assigned

— For loaded holds

The maximum permissible mass ( $W_{max}(T_i)$ ) at various draughts ( $T_i$ ) is the same specified in [2.1.2].  
The minimum required mass ( $W_{min}(T_i)$ ) is obtained, in t, by the following formulae:

$$\begin{aligned}
 W_{min}(T_i) &= 0 && \text{for } T_i \leq T_{HB} \\
 W_{min}(T_i) &= 1.025V_H \frac{(T_i - T_{HB})}{h} && \text{for } T_S \geq T_i > T_{HB} \quad \text{or} \\
 W_{min}(T_i) &= 0.5M_H - 1.025V_H \frac{(T_S - T_i)}{h} \geq 0 && \text{for } T_S \geq T_i
 \end{aligned}$$

— For empty hold which can be empty at the maximum draught

The maximum permissible mass ( $W_{max}(T_i)$ ) at various draughts ( $T_i$ ) is obtained, in t, by the following formulae:

$$W_{max}(T_i) = M_{Full} - 1.025V_H \frac{(T_S - T_i)}{h}$$

The minimum required cargo mass ( $W_{min}(T_i)$ ) at various draughts ( $T_i$ ) is obtained, in t, by the following formulae:

$$W_{min}(T_i) = 0 \quad \text{for } T_i \leq T_S$$

Examples for mass curve of cargo hold for **BC-A** ships, having {No MP} assigned are shown in Fig 2.

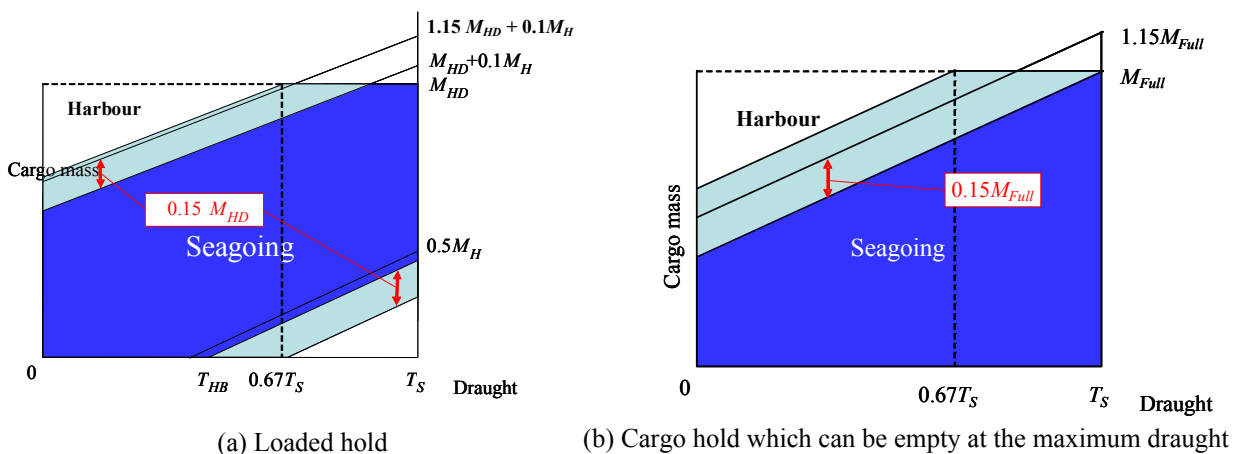

Fig. 2  
Example of mass curve for **BC-A** ships having {No MP} assigned

### 2.1.4 BC-B and BC-C ships not having {No MP} assigned

The maximum permissible mass ( $W_{\max}(T_i)$ ) at various draughts ( $T_i$ ) is obtained, in t, by the following formulae:

$$W_{\max}(T_i) = M_{Full} \quad \text{for} \quad T_S \geq T_i \geq 0.67T_S$$

$$W_{\max}(T_i) = M_{Full} - 1.025V_H \frac{(0.67T_S - T_i)}{h} \quad \text{for} \quad T_i < 0.67T_S$$

The minimum required cargo mass ( $W_{\min}(T_i)$ ) at various draughts ( $T_i$ ) is obtained, in t, by the following formulae:

$$W_{\min}(T_i) = 0 \quad \text{for} \quad T_i \leq 0.83T_S$$

$$W_{\min}(T_i) = 1.025V_H \frac{(T_i - 0.83T_S)}{h} \quad \text{for} \quad T_S \geq T_i > 0.83T_S$$

Example for mass curve of cargo hold for **BC-B** and **BC-C** ships is shown in Fig. 3.

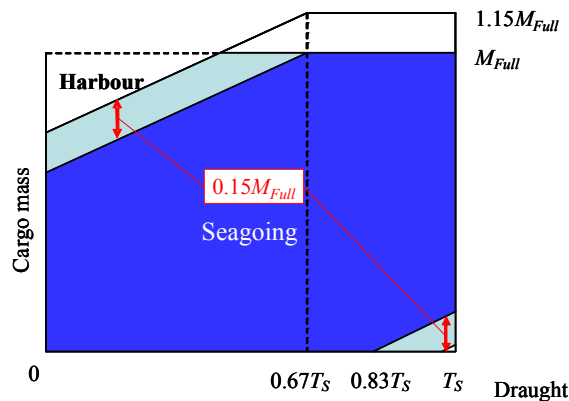

Fig. 3  
Example of mass curve for **BC-B** and **BC-C** ships not having {No MP} assigned

### 2.1.5 BC-B and BC-C ships having {No MP} assigned

The maximum permissible mass ( $W_{\max}(T_i)$ ) at various draughts  $T_i$  is obtained, in t, by the following formulae:

$$W_{\max}(T_i) = M_{Full} - 1.025V_H \frac{(T_S - T_i)}{h}$$

The minimum required cargo mass ( $W_{\min}(T_i)$ ) at various draughts ( $T_i$ ) is obtained, in t, by the following formulae:

$$W_{\min}(T_i) = 0 \quad \text{for} \quad T_i \leq T_{HB}$$

$$W_{\min}(T_i) = 1.025V_H \frac{(T_i - T_{HB})}{h} \quad \text{for} \quad T_S \geq T_i > T_{HB} \quad \text{or}$$

$$W_{\min}(T_i) = 0.5M_H - 1.025V_H \frac{(T_S - T_i)}{h} \quad \text{for} \quad T_S \geq T_i$$

$$W_{\min}(T_i) \geq 0.0$$

Example for mass curve of cargo hold for **BC-B** or **BC-C** ships with {No MP} is shown in Fig 4.

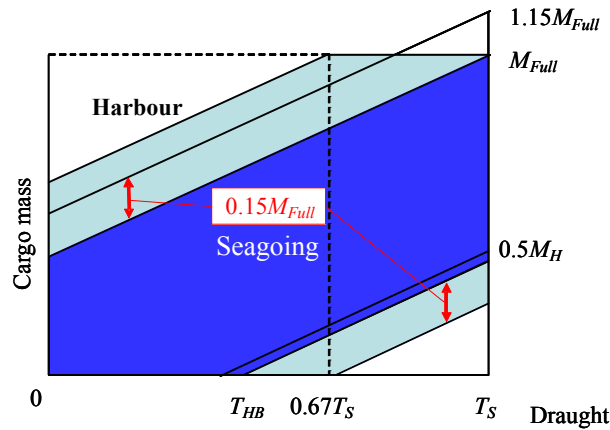

Fig. 4  
Example of mass curve for BC-B and BC-C ships having {No MP} assigned

## 2.2 Maximum permissible mass and minimum required masses of single cargo hold in harbour condition

### 2.2.1 General

The cargo mass curves of single cargo hold in harbour condition are defined in [2.2.2]. However if the ship structure is checked for more severe loading conditions than ones considered in Ch 4, Sec 7, [3.7.1], the minimum required cargo mass and the maximum allowable cargo mass can be based on those corresponding loading conditions.

### 2.2.2 All ships

The maximum permissible cargo mass and the minimum required cargo mass corresponding to draught for loading/unloading conditions in harbour may be increased or decreased by 15% of the maximum permissible mass at the maximum draught for the cargo hold in seagoing condition. However, maximum permissible mass is in no case to be greater than the maximum permissible cargo mass at designed maximum load draught for each cargo hold.

### 2.2.3 BC-A ship not having {No MP} assigned

The maximum permissible mass ( $W_{\max}(T_i)$ ) at various draughts  $T_i$  in harbour condition is also to be checked by the following formulae in addition to the requirements in [2.1.2]:

$$\begin{aligned} &\text{For loaded hold} \\ &W_{\max}(T_i) = M_{HD} \quad \text{for} \quad T_i \geq 0.67T_S \\ &W_{\max}(T_i) = M_{HD} + 0.1M_H - 1.025V_H \frac{0.67T_S - T_i}{h} \quad \text{for} \quad T_i < 0.67T_S \end{aligned}$$

### 2.2.4 BC-A ship having {No MP} assigned

The maximum permissible mass ( $W_{\max}(T_i)$ ) at various draughts  $T_i$  in harbour condition is also to be checked by the following formulae in addition to the requirements in [2.1.3]:

$$\begin{aligned} &\text{For empty hold which can be empty at the maximum draught} \\ &W_{\max}(T_i) = M_{Full} \quad \text{for} \quad T_S \geq T_i \geq 0.67T_S \\ &W_{\max}(T_i) = M_{Full} - 1.025V_H \frac{(0.67T_S - T_i)}{h} \quad \text{for} \quad T_i < 0.67T_S \end{aligned}$$

### 2.2.5 BC-B and BC-C ships having {No MP} assigned

The maximum permissible mass ( $W_{\max}(T_i)$ ) at various draughts  $T_i$  in harbour condition is also to be checked by the following formulae in addition to the requirements in [2.2.2]:

$$\begin{aligned} &W_{\max}(T_i) = M_{Full} \quad \text{for} \quad T_S \geq T_i \geq 0.67T_S \\ &W_{\max}(T_i) = M_{Full} - 1.025V_H \frac{(0.67T_S - T_i)}{h} \quad \text{for} \quad T_i < 0.67T_S \end{aligned}$$

### 3 Maximum and minimum masses of cargo of two adjacent holds

#### 3.1 Maximum permissible mass and minimum required masses of two adjacent holds in seagoing condition

##### 3.1.1 General

The cargo mass curves of two adjacent cargo holds in seagoing condition are defined in [3.1.2] and [3.1.3]. However if the ship structure is checked for more severe loading conditions than ones considered in Ch 4, Sec 7, [3.7.1], the minimum required cargo mass can be based on those corresponding loading conditions.

##### 3.1.2 BC-A ships with “Block loading” and not having {No MP} assigned

The maximum permissible mass ( $W_{\max}(T_i)$ ) at various draughts ( $T_i$ ) is obtained, in t, by the greater of the following formulae:

$$W_{\max}(T_i) = \sum (M_{BLK} + 0.1M_H) - 1.025 \left( \frac{V_f}{h_f} + \frac{V_a}{h_a} \right) (T_s - T_i) \quad \text{or}$$

$$W_{\max}(T_i) = \sum M_{Full} - 1.025 \left( \frac{V_f}{h_f} + \frac{V_a}{h_a} \right) (0.67T_s - T_i)$$

However,  $W_{\max}(T_i)$  is no case to be greater than  $\Sigma M_{BLK}$ .

The minimum required cargo mass ( $W_{\min}(T_i)$ ) at various draughts ( $T_i$ ) is obtained, in t, by the following formulae:

$$W_{\min}(T_i) = 0 \quad \text{for } T_i \leq 0.75T_s$$

$$W_{\min}(T_i) = 1.025 \left( \frac{V_f}{h_f} + \frac{V_a}{h_a} \right) (T_i - 0.75T_s) \quad \text{for } T_s \geq T_i > 0.75T_s$$

##### 3.1.2 bis BC-A ships with “Block loading” and having {No MP} assigned

The maximum permissible mass  $W_{\max}(T_i)$  at various draughts  $T_i$  is obtained, in t, by the following formula:

$$W_{\max}(T_i) = \sum (M_{BLK} + 0.1M_H) - 1.025 \left( \frac{V_f}{h_f} + \frac{V_a}{h_a} \right) (T_s - T_i)$$

However,  $W_{\max}(T_i)$  is no case to be greater than  $\Sigma M_{BLK}$ .

The minimum required cargo mass  $W_{\min}(T_i)$  at various draughts  $T_i$  is obtained, in t, by the following formulae:

$$W_{\min}(T_i) = 0 \quad \text{for } T_i \leq T_{HB}$$

$$W_{\min}(T_i) = 1.025 \left( \frac{V_f}{h_f} + \frac{V_a}{h_a} \right) (T_i - T_{HB}) \quad \text{for } T_s \geq T_i > T_{HB}$$

Examples for mass curve of cargo hold for BC-A with block loading ships are shown in Fig 5.

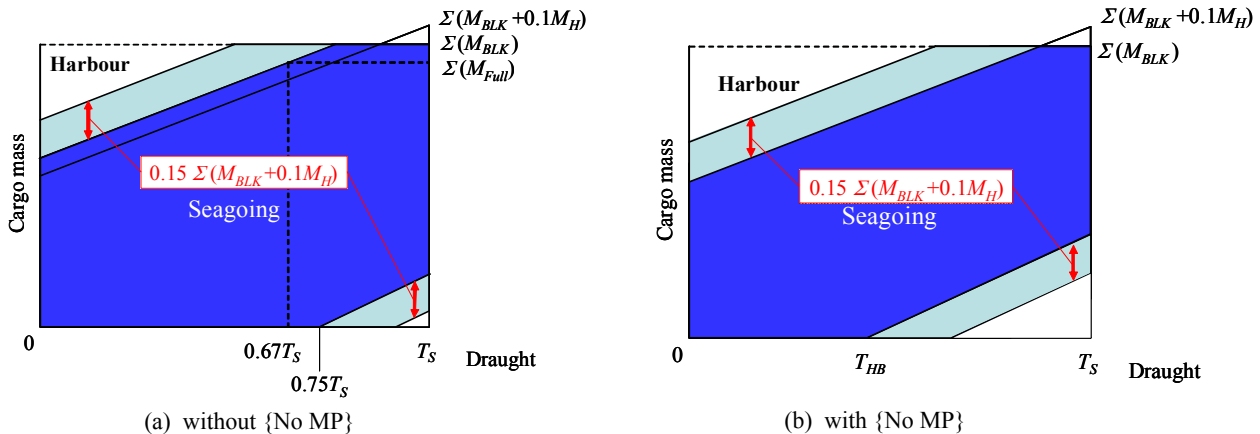

Fig. 5  
Example of mass curve for BC-A ships with “Block loading”



### 3.1.3 (void)

### 3.1.4 BC-A ships without “Block loading” and BC-B, BC-C ships, not having {No MP} assigned

The maximum permissible mass ( $W_{\max}(T_i)$ ) at various draughts  $T_i$  is obtained, in t, by the following formulae:

$$W_{\max}(T_i) = \sum M_{Full} \quad \text{for } T_S \geq T_i \geq 0.67T_S$$

$$W_{\max}(T_i) = \sum M_{Full} - 1.025 \left( \frac{V_f}{h_f} + \frac{V_a}{h_a} \right) (0.67T_S - T_i) \quad \text{for } T_i < 0.67T_S$$

The minimum required cargo mass ( $W_{\min}(T_i)$ ) at various draughts  $T_i$  is obtained, in t, by the following formulae:

$$W_{\min}(T_i) = 0 \quad \text{for } T_i \leq 0.75T_S$$

$$W_{\min}(T_i) = 1.025 \left( \frac{V_f}{h_f} + \frac{V_a}{h_a} \right) (T_i - 0.75T_S) \quad \text{for } T_S \geq T_i > 0.75T_S$$

### 3.1.5 BC-A ships without “Block loading” and BC-B, BC-C ships, having {No MP} assigned

The maximum permissible mass ( $W_{\max}(T_i)$ ) at various draughts  $T_i$  is obtained, in t, by the following formulae:

$$W_{\max}(T_i) = \sum M_{Full} - 1.025 \left( \frac{V_f}{h_f} + \frac{V_a}{h_a} \right) (T_S - T_i) \quad \text{for } T_i < T_S$$

The minimum required cargo mass ( $W_{\min}(T_i)$ ) at various draughts  $T_i$  is obtained, in t, by the following formulae:

$$W_{\min}(T_i) = 0 \quad \text{for } T_i \leq T_{HB}$$

$$W_{\min}(T_i) = 1.025 \left( \frac{V_f}{h_f} + \frac{V_a}{h_a} \right) (T_i - T_{HB}) \quad \text{for } T_S \geq T_i > T_{HB}$$

Examples for mass curve of cargo hold for **BC-A** without block loading and **BC-B** or **BC-C** are shown in Fig 6.

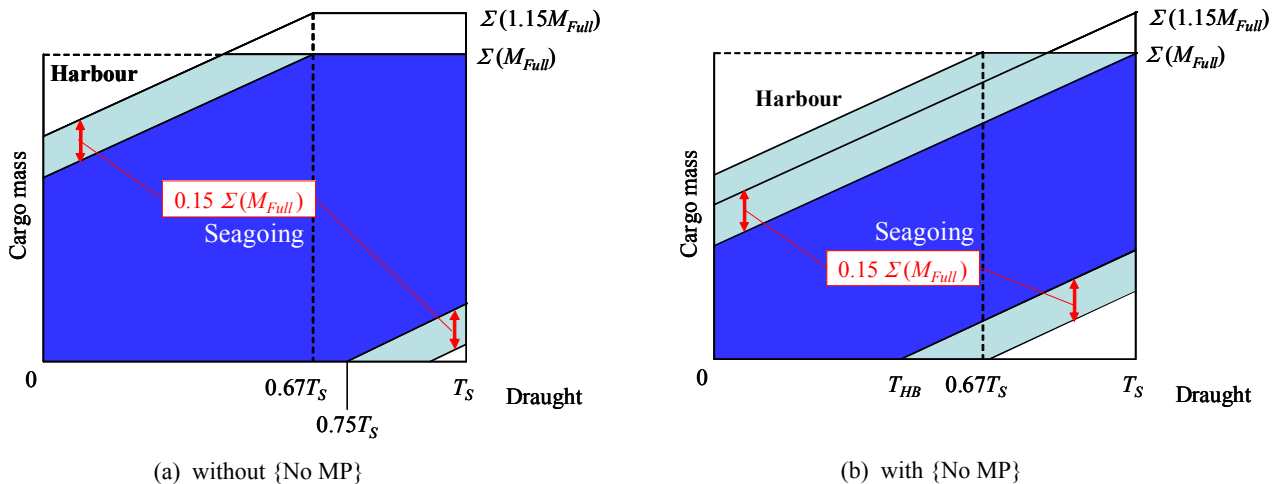

Fig. 6  
Example of mass curve for **BC-A** ship without block loading and **BC-B** or **BC-C** ships

## 3.2 Maximum permissible mass and minimum required masses of two adjacent cargo holds in harbour condition

### 3.2.1 General

The cargo mass curves of two adjacent cargo holds in harbour condition are defined in [3.2.2]. However if the ship structure is checked for more severe loading conditions than ones considered in Ch 4, Sec 7, [3.7.1], the minimum required cargo mass and the maximum allowable cargo mass can be based on those corresponding loading conditions.

### 3.2.2 All ships

The maximum permissible cargo mass and minimum required cargo mass corresponding to draught for loading/unloading conditions in harbour may be increased or decreased by 15% of the maximum permissible mass at the maximum draught for the cargo hold in seagoing condition. However, maximum permissible mass is in no case to be greater than the maximum permissible cargo mass at designed maximum load draught for each cargo hold.

### 3.2.3 BC-A ships with “Block loading” and having {No MP} assigned

The maximum permissible mass ( $W_{\max}(T_i)$ ) at various draughts  $T_i$  in harbour condition is also to be checked by the following formulae in addition to the requirements in [3.1.2 bis]:

$$W_{\max}(T_i) = \sum M_{Full} - 1.025 \left( \frac{V_f}{h_f} + \frac{V_a}{h_a} \right) (0.67T_s - T_i)$$

$$W_{\max}(T_i) \leq \sum M_{BLK}$$

### 3.2.4 BC-A ships without “Block loading” and BC-B, BC-C ships, having {No MP} assigned

The maximum permissible mass ( $W_{\max}(T_i)$ ) at various draughts  $T_i$  in harbour condition is also to be checked by the following formulae in addition to the requirements in [3.1.5]:

$$W_{\max}(T_i) = \sum M_{Full} \quad \text{for } T_s \geq T_i \geq 0.67T_s$$

$$W_{\max}(T_i) = \sum M_{Full} - 1.025 \left( \frac{V_f}{h_f} + \frac{V_a}{h_a} \right) (0.67T_s - T_i) \quad \text{for } T_i < 0.67T_s$$

## APPENDIX 2 STANDARD LOADING CONDITION FOR DIRECT STRENGTH ANALYSIS

No.	Description <sup>a)</sup>	Draught	Loading Pattern	Fore			Load Case (Design Wave)			Remarks (see below)			
				Aft	Mid	Fore	Still water vertical bending moment <sup>b)</sup>						
1	Full Load ([2.1.3])	$T_S$					P1				1), 2)		
2	Full Load ([3.2.1])	$T_S$					P1					1), 3)	
							0.5M <sub>SW,S</sub>						
3	Slack Load ([3.2.2])	$T_S$					P1					3)	
							0						
4	Slack Load ([3.2.2])	$T_S$					P1					3)	
							0						
5	Deepest Ballast ([3.2.3])	$T_{HB}$					R1			P1		4), 5)	
							M <sub>SW,H</sub>		M <sub>SW,S</sub>	M <sub>SW,S</sub>			
							H1						
6	Multi Port -3 ([3.3.3])	0.67T <sub>S</sub>					H1					3), 6)	
							M <sub>SW,S</sub>						
7	Multi Port -3 ([3.3.3])	0.67T <sub>S</sub>					H1					3), 6)	
							M <sub>SW,S</sub>						
8	Multi Port -4 ([3.3.4])	0.75T <sub>S</sub>					F2			P1		3), 6)	
							M <sub>SW,H</sub>		M <sub>SW,S</sub>	M <sub>SW,S</sub>			

Table 1 Bending moment analysis applicable to empty hold in alternate condition of BC-A (mid-hold is empty hold) (Continued)											
No.	Description <sup>a)</sup>	Draught	Loading Pattern	Fore			Load Case (Design Wave)			Remarks (see below)	
				Aft	Mid	Fore	Still water vertical bending moment <sup>b)</sup>				
9	Multi Port -4 ([3.3.4])	0.75T <sub>S</sub>					F2	P1			3), 6)
							M <sub>SW,H</sub>	M <sub>SW,S</sub>			
10	Alternate Load ([3.4.1])	T <sub>S</sub>					F2	P1			2)
							M <sub>SW,H</sub>	0			
11	Alt-Block Load ([3.4.3])	T <sub>S</sub>					H1	F2	P1		2), 8), 9), 10)
							M <sub>SW,S</sub>	M <sub>SW,H</sub>	M <sub>SW,S</sub>		
12	Alt-Block Load ([3.4.3])	T <sub>S</sub>					H1	F2	P1		2), 8), 9), 10)
							M <sub>SW,S</sub>	M <sub>SW,H</sub>	M <sub>SW,S</sub>		
13	Heavy Ballast ([3.5.1])	T <sub>HB(min)</sub>					H1	R1	R1		11), 12)
							M <sub>SW,S</sub>	0	M <sub>SW,S</sub>		
14	Heavy Ballast ([3.5.1])	T <sub>HB(min)</sub>					R1	R1			11), 12), 13)
							0	M <sub>SW,S</sub>			

**Table 1 Bending moment analysis applicable to empty hold in alternate condition of BC-A (mid-hold is empty hold) (Continued)**

No.	Description <sup>a)</sup>	Draught	Loading Pattern	Aft	Mid	Fore	Load Case (Design Wave)		Remarks (see below)
							Still water vertical bending moment <sup>b)</sup>		
15	Harbour Condition - 2 ([3.6.2])	0.67T <sub>S</sub>					---	---	3), 14), 15)
16	Harbour Condition - 2 ([3.6.2])	0.67T <sub>S</sub>					---	M <sub>SW,P,S</sub>	3), 14), 15)

a) Referred paragraph number corresponds to loading pattern prescribed in Ch 4, Sec 7.

b)

$M_{SW,H}$ ,  $M_{SW,S}$  = Allowable still water vertical bending moment for seagoing condition, hogging or sagging respectively  
 $M_{SW,P,H}$ ,  $M_{SW,P,S}$  = Allowable still water vertical bending moment for harbour condition, hogging or sagging respectively

**Remarks**

- 1) Single loading pattern in  $M_{Full}$  with cargo density of 3.0 t/m<sup>3</sup> can be analyzed in lieu of these two loading patterns.
- 2) Cargo density 3.0 t/m<sup>3</sup> is to be used for calculation of dry cargo pressure in principle.
- 3)  $M_H/V_H$  or 1.0 t/m<sup>3</sup>, whichever is greater, is to be used as cargo density for calculation of dry cargo pressure.
- 4) In case of no ballast hold, normal ballast condition with assuming  $M_{SW,S} = 0$  is to be analyzed.
- 5) Position of ballast hold is to be adjusted as appropriate.
- 6) This condition is not required when **{no MP}** notation is assigned.
- 7) For vertical shear force analysis, maximum shear force ( $Q_{SW} + Q_{HT}$ ) with reduced vertical bending moment ( $0.8M_{SW} + 0.65C_{WT}M_{HT}$ ) is to be considered.
- 8) This condition is only required when such a condition is prepared in the loading manual.
- 9) “ $M_{BLK}$ ” is maximum cargo mass according to the design loading condition in the loading manual.
- 10) Actual still water vertical bending moment, as given in the loading manual, may be used in stead of design value.
- 11) This condition is to be considered for the empty hold which is assigned as ballast hold if any.
- 12) Minimum draught among heavy ballast conditions is to be used in principle.
- 13) This condition is not required when such a condition is explicitly prohibited in the loading manual.
- 14) This condition is to be analyzed when **{no MP}** notation is assigned.
- 15) External sea pressures and internal pressures can be considered as static.

**Table 2 Shear force analysis applicable to empty hold of BC-A (mid-hold is empty hold)**

No.	Description <sup>a)</sup>	Draught	Loading Pattern	Aft			Mid			Fore			Load Case (Design Wave)			Remarks (see Table 1 above)
				Aft	Mid	Fore	Aft	Mid	Fore	Still water vertical bending moment <sup>b)</sup>	Still water shear force					
10SF	Alternate Load ([3.4.1])	$T_S$											F2	$0.8M_{SW,H}$	$Q_{SW}$	2), 7)
13SF	Heavy Ballast ([3.5.1])	$T_{HB}(\text{min})$											H1	$0.8M_{SW,S}$	$Q_{SW}$	7), 11), 12)

a) Referred paragraph number corresponds to loading pattern prescribed in Ch 4, Sec 7.

b)  $M_{SW,H}$ ,  $M_{SW,S}$  = Allowable still water vertical bending moment for seagoing condition, hogging or sagging respectively.

**Table 3 Bending moment analysis applicable to loaded hold in alternate condition of BC-A (mid-hold is loaded hold)**

No.	Description <sup>a)</sup>	Draught	Loading Pattern	Aft			Mid			Fore			Load Case (Design Wave)			Remarks (see below)	
				Aft	Mid	Fore	Aft	Mid	Fore	Still water vertical bending moment <sup>b)</sup>							
1	Full Load ([2.1.3])	$T_S$											P1	$0.5M_{SW,S}$		1), 2)	
2	Full Load ([3.2.1])	$T_S$											P1	$0.5M_{SW,S}$		1), 3)	
3	Slack Load ([3.2.2])	$T_S$											P1	0		3)	
4	Deepest Ballast ([3.2.3])	$T_{HB}$											R1	$M_{SW,H}$	R1	P1	4), 5)

**Table 3 Bending moment analysis applicable to loaded hold in alternate condition of BC-A (mid-hold is loaded hold) (Continued)**

No.	Description <sup>a)</sup>	Draught	Loading Pattern	Aft			Mid			Fore			Load Case (Design Wave)			Remarks (see below)	
				Still water vertical bending moment <sup>b)</sup>			Still water vertical bending moment <sup>b)</sup>			Still water vertical bending moment <sup>b)</sup>			Still water vertical bending moment <sup>b)</sup>				
5	Multi Port -2 ([3.3.2])	0.83T <sub>S</sub>					F2	P1	M <sub>SW,H</sub>	M <sub>SW,S</sub>	M <sub>SW,S</sub>	F2	P1	M <sub>SW,S</sub>	M <sub>SW,S</sub>	M <sub>SW,S</sub>	3), 6)
6	Multi Port -3 ([3.3.3])	0.67T <sub>S</sub>					P1		M <sub>SW,S</sub>			P1					3), 6)
7	Multi Port -3 ([3.3.3])	0.67T <sub>S</sub>					P1		M <sub>SW,S</sub>			P1					3), 6)
8	Multi Port -4 ([3.3.4])	0.75T <sub>S</sub>					F2	R1	M <sub>SW,H</sub>	M <sub>SW,S</sub>	M <sub>SW,S</sub>	F2	R1	M <sub>SW,S</sub>	M <sub>SW,S</sub>	M <sub>SW,S</sub>	3), 6)
9	Multi Port -4 ([3.3.4])	0.75T <sub>S</sub>					F2	R1	M <sub>SW,H</sub>	M <sub>SW,S</sub>	M <sub>SW,S</sub>	F2	R1	M <sub>SW,S</sub>	M <sub>SW,S</sub>	M <sub>SW,S</sub>	3), 6)
10	Alternate Load ([3.4.2])	T <sub>S</sub>					F2	P1	0			F2	P1				2)
11	Alt-Block Load ([3.4.3])	T <sub>S</sub>					H1	F2	M <sub>SW,S</sub>	M <sub>SW,H</sub>	M <sub>SW,S</sub>	H1	P1	M <sub>SW,S</sub>			2), 8), 9), 10)
12	Alt-Block Load ([3.4.3])	T <sub>S</sub>					H1	F2	M <sub>SW,S</sub>	M <sub>SW,H</sub>	M <sub>SW,S</sub>	H1	P1	M <sub>SW,S</sub>			2), 8), 9), 10)

**Table 3 Bending moment analysis applicable to loaded hold in alternate condition of BC-A (mid-hold is loaded hold) (Continued)**

No.	Description <sup>a)</sup>	Draught	Loading Pattern	Aft			Mid			Fore			Load Case (Design Wave)			Remarks (see below)
13	Heavy Ballast ([3.5.1])	$T_{HB}(\text{min})$					H1	R1	R1	$M_{SW,S}$	0	$M_{SW,S}$	R1	$M_{SW,S}$		11), 12)
14	Heavy Ballast	$T_{HB}(\text{min})$					R1	R1	R1	$M_{SW,S}$	0	$M_{SW,S}$	R1	$M_{SW,S}$		11), 12), 13)
15	HarbourCondition -1 ([3.6.1])	$0.67T_S$					---	---	---	$M_{SW,P,H}$	$M_{SW,P,H}$	$M_{SW,P,S}$	---	$M_{SW,P,S}$		2), 15)
16	HarbourCondition -1 ([3.6.1])	$0.67T_S$					---	---	---	$M_{SW,P,H}$	$M_{SW,P,H}$	$M_{SW,P,S}$	---	$M_{SW,P,S}$		3), 14), 15)
17	HarbourCondition -1 ([3.6.1])	$0.67T_S$					---	---	---	$M_{SW,P,H}$	$M_{SW,P,H}$	$M_{SW,P,S}$	---	$M_{SW,P,S}$		3), 14), 15)



**Table 3 Bending moment analysis applicable to loaded hold in alternate condition of BC-A (mid-hold is loaded hold) (Continued)**

No.	Description <sup>a)</sup>	Draught	Loading Pattern	Aft	Mid	Fore	Load Case (Design Wave)		Remarks (see below)
							Still water vertical bending moment <sup>b)</sup>		
18	HarbourCondition -2 ([3.6.2])	0.67T <sub>S</sub>					---	---	3), 14), 15)
19	HarbourCondition -2 ([3.6.2])	0.67T <sub>S</sub>					M <sub>SW,P,H</sub>	M <sub>SW,P,S</sub>	3), 14), 15)

a) Referred paragraph number corresponds to loading pattern prescribed in Ch 4, Sec 7.

b)

$M_{SW,H}$ ,  $M_{SW,S}$  = Allowable still water vertical bending moment for seagoing condition, hogging or sagging respectively  
 $M_{SW,P,H}$ ,  $M_{SW,P,S}$  = Allowable still water vertical bending moment for harbour condition, hogging or sagging respectively

**Remarks**

- 1) Single loading pattern in  $M_{Full}$  with cargo density of 3.0 t/m<sup>3</sup> can be analyzed in lieu of these two loading patterns.
- 2) Cargo density 3.0 t/m<sup>3</sup> is to be used for calculation of dry cargo pressure in principle.
- 3)  $M_H/V_H$  or 1.0 t/m<sup>3</sup>, whichever is greater, is to be used as cargo density for calculation of dry cargo pressure.
- 4) In case of no ballast hold, normal ballast condition with assuming  $M_{SW,S} = 0$  is to be analyzed.
- 5) Position of ballast hold is to be adjusted as appropriate.
- 6) This condition is not required when **{no MP}** notation is assigned.
- 7) For vertical shear force analysis, maximum shear force ( $Q_{SW} + Q_{WP}$ ) with reduced vertical bending moment ( $0.8M_{SW} + 0.65C_{WP}M_{WP}$ ) is to be considered.
- 8) This condition is only required when such a condition is prepared in the loading manual.
- 9) “ $M_{BLK}$ ” is maximum cargo mass according to the design loading condition in the loading manual.
- 10) Actual still water vertical bending moment, as given in the loading manual, may be used in stead of design value.
- 11) This condition is to be considered for the loaded hold which is assigned as ballast hold if any.
- 12) Minimum draught among heavy ballast conditions is to be used in principle.
- 13) This condition is not required when such a condition is explicitly prohibited in the loading manual.
- 14) This condition is to be analyzed when **{no MP}** notation is assigned.
- 15) External sea pressures and internal pressures can be considered as static.

**Table 4 Shear force analysis applicable to loaded hold of BC-A (mid-hold is loaded hold)**

No.	Description <sup>a)</sup>	Draught	Loading Pattern	Fore			Load Case (Design Wave)			Remarks (see Table 3 above)
				Aft	Mid	Fore	Still water vertical bending moment <sup>b)</sup>			
				Still water shear force						
10SF	Alternate Load ([3.4.2])	$T_S$					F2	$0.8M_{SW,H}$	$Q_{SW}$	2), 7)
13SF	Heavy Ballast ([3.5.1])	$T_{HB}(\text{min})$					H1	$0.8M_{SW,S}$	$Q_{SW}$	7), 11), 12)

a) Referred paragraph number corresponds to loading pattern prescribed in Ch 4, Sec 7.

b)  $M_{SW,H}$ ,  $M_{SW,S}$  = Allowable still water vertical bending moment for seagoing condition, hogging or sagging respectively

**Table 5 Bending moment analysis applicable to BC-B and BC-C**

No.	Description <sup>a)</sup>	Draught	Loading Pattern	Fore			Load Case (Design Wave)			Remarks (see below)	
				Aft	Mid	Fore	Still water vertical bending moment <sup>b)</sup>				
				Still water vertical bending moment <sup>b)</sup>							
1	Full Load ([2.1.3])	$T_S$					P1	$0.5M_{SW,S}$		1), 2), 3)	
2	Full Load ([3.2.1])	$T_S$					P1	$0.5M_{SW,S}$		2), 4)	
3	Slack Load ([3.2.2])	$T_S$					P1	0		4)	
4	Deepest Ballast ([3.2.3])	$T_{HB}$					R1	$M_{SW,H}$	$M_{SW,S}$	$M_{SW,H}$	5), 6), 14)

**Table 5 Bending moment analysis applicable to BC-B and BC-C (Continued)**

No.	Description <sup>a)</sup>	Draught	Loading Pattern	Fore			Load Case (Design Wave)			Remarks (see below)		
				Aft	Mid	Fore	Still water vertical bending moment <sup>b)</sup>					
5	Multi Port -2 ([3.3.2])	0.83T <sub>S</sub>					F2	P1			4), 7)	
							M <sub>SW,H</sub>	M <sub>SW,S</sub>				
6	Multi Port -3 ([3.3.3])	0.67T <sub>S</sub>					P1					4), 7)
							M <sub>SW,S</sub>					
7	Multi Port -3 ([3.3.3])	0.67T <sub>S</sub>					P1					4), 7)
							M <sub>SW,S</sub>					
8	Multi Port -4 ([3.3.4])	0.75T <sub>S</sub>					F2	R1	R1	P1		4), 7)
							M <sub>SW,H</sub>	M <sub>SW,H</sub>	M <sub>SW,S</sub>	M <sub>SW,S</sub>		
9	Multi Port -4 ([3.3.4])	0.75T <sub>S</sub>					F2	R1	R1	P1		4), 7)
							M <sub>SW,H</sub>	M <sub>SW,H</sub>	M <sub>SW,S</sub>	M <sub>SW,S</sub>		
10	Heavy Ballast ([3.5.1])	T <sub>HB</sub> (min)					H1	R1	R1			9), 10)
							M <sub>SW,S</sub>	0	M <sub>SW,S</sub>			
11	Heavy Ballast	T <sub>HB</sub> (min)					R1	R1				9), 10), 11)
							0	M <sub>SW,S</sub>				
12	Harbour Condition -1 ([3.6.1])	0.67T <sub>S</sub>					---	---	---			4), 12), 13)
							M <sub>S,P</sub> (+)	M <sub>S,P</sub> (-)				

**Table 5 Bending moment analysis applicable to BC-B and BC-C (Continued)**

No.	Description <sup>a)</sup>	Draught	Loading Pattern			Fore	Load Case (Design Wave)		Remarks (see below)
			Aft	Mid	Fore		Still water vertical bending moment <sup>b)</sup>		
13	Harbour Condition -1 ([3.6.1])	0.67T <sub>S</sub>					---	---	4), 12), 13)
14	Harbour Condition -2 ([3.6.2])	0.67T <sub>S</sub>					---	M <sub>S,P</sub> (-)	4), 12), 13)
15	Harbour Condition -2 ([3.6.2])	0.67T <sub>S</sub>					---	M <sub>S,P</sub> (-)	4), 12), 13)

a) Referred paragraph number corresponds to loading pattern prescribed in Ch 4, Sec 7.









b)

$M_{SW,H}$ ,  $M_{SW,S}$  = Allowable still water vertical bending moment for seagoing condition, hogging or sagging respectively  
 $M_{SW,P,H}$ ,  $M_{SW,P,S}$  = Allowable still water vertical bending moment for harbour condition, hogging or sagging respectively

**Remarks**

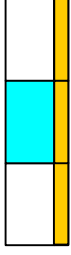
- 1) Applicable to **BC-B** only.
- 2) For **BC-B** single loading pattern in  $M_{Full}$  with cargo density of 3.0 t/m<sup>3</sup> can be analyzed in lieu of these two loading patterns.
- 3) Cargo density 3.0 t/m<sup>3</sup> is to be used for calculation of dry cargo pressure in principle.
- 4)  $M_H/V_H$  or 1.0 t/m<sup>3</sup>, whichever is greater, is to be used as cargo density for calculation of dry cargo pressure.
- 5) In case of no ballast hold, normal ballast condition with assuming  $M_{SW,S} = 0$  is to be analyzed.
- 6) Position of ballast hold is to be adjusted as appropriate.
- 7) This condition is not required when **{no MP}** notation is assigned.
- 8) For vertical shear force analysis, maximum shear force ( $Q_{SW} + Q_{HT}$ ) with reduced vertical bending moment ( $0.8M_{SW} + 0.65C_{HT}M_{HT}$ ) is to be considered.
- 9) This condition is to be considered for the cargo hold which is assigned as ballast hold if any.
- 10) Minimum draught among heavy ballast conditions is to be used in principle.
- 11) This condition is not required when such a condition is explicitly prohibited in the loading manual.
- 12) This condition is to be analyzed when **{no MP}** notation is assigned.
- 13) External sea pressures and internal pressures can be considered as static.
- 14) Load case F2 is to be analyzed when **{no MP}** notation is assigned.

**Table 6 Shear force analysis applicable to BC-B and BC-C**

No.	Description <sup>a)</sup>	Draught	Loading Pattern	Fore			Load Case (Design Wave)		Remarks (see Table 5 above)
				Aft	Mid	Fore	Still water vertical bending moment <sup>b)</sup>	Still water shear force	
5SF	Multi Port -2 ([3.3.2])	0.83T <sub>S</sub>					F2 0.8M <sub>SW,H</sub> Q <sub>SW</sub>		4), 7), 8)
10SF	Heavy Ballast ([3.5.1])	T <sub>HB</sub> (min)					H1 0.8M <sub>SW,S</sub> Q <sub>SW</sub>		8), 9), 10)

a) Referred paragraph number corresponds to loading pattern prescribed in Ch 4, Sec 7.

b) M<sub>SW,H</sub>, M<sub>SW,S</sub> = Allowable still water vertical bending moment for seagoing condition, hogging or sagging respectively.

### APPENDIX 3 STANDARD LOADING CONDITION FOR FATIGUE ASSESSMENT

Table 1 Fatigue Assessment applicable to empty hold in alternate condition of BC-A (mid-hold is empty hold)																	
No.	Description	Draught <sup>a)</sup>	Loading pattern	Aft			Mid			Fore			Load case (Design wave)	Still water vertical bending moment <sup>b)</sup>	Remarks (see below)		
				H1	F1	R1	H1	F1	R1	H1	F1	R1					
1	Full Load	<i>T</i>											F1 F2	R1 R2	P1 P2	$M_{S,(1)}$	1)
2	Alternate Load	<i>T</i>											F1 F2	R1 R2	P1 P2	$M_{S,(2)}$	2)
3	Normal Ballast	$T_{NB}$											F1 F2	R1 R2	P1 P2	$M_{S,(3)}$	
4	Heavy Ballast	$T_{HB}$											F1 F2	R1 R2	P1 P2	$M_{S,(4)}$	3)
													F1 F2	R1 R2	P1 P2	$M_{S,(4)}$	4)

a) *T* = Moulded draught,  $T_{NB}$  = Draught at normal ballast condition,  $T_{HB}$  = Draught at heavy ballast condition  
 b)  $M_{S,(1)}$ ,  $M_{S,(2)}$ ,  $M_{S,(3)}$ ,  $M_{S,(4)}$  = Still water vertical bending moment as defined in [3.2.2] of Ch 8, Sec 3

**Remarks**

- 1)  $M_H/V_H$  is to be used as cargo density for calculation of dry cargo pressure.
- 2) Cargo density 3.0 t/m<sup>3</sup> is to be used for calculation of dry cargo pressure in principle.
- 3) This condition is to be applied only for the empty hold which is not assigned as ballast hold. Position of ballast hold is to be adjusted as appropriate.
- 4) This condition is to be applied only for the empty hold which is assigned as ballast hold.

**Table 2 Fatigue Assessment applicable to loaded hold in alternate condition of BC-A (mid-hold is loaded hold)**

No.	Description	Draught <sup>a)</sup>	Loading pattern	Aft			Mid	Fore	Load case (Design wave)				Still water vertical bending moment <sup>b)</sup>	Remarks (see below)
								H1	F1	R1	P1	H2		
1	Full Load	<i>T</i>							H1	F1	R1	P1	$M_{S,(1)}$	1)
								H2	F2	R2	P2			
2	Alternate Load	<i>T</i>							H1	F1	R1	P1	$M_{S,(2)}$	2)
								H2	F2	R2	P2			
3	Normal Ballast	$T_{NB}$							H1	F1	R1	P1	$M_{S,(3)}$	
								H2	F2	R2	P2			
4	Heavy Ballast	$T_{HB}$							H1	F1	R1	P1	$M_{S,(4)}$	3)
								H2	F2	R2	P2			
								H1	F1	R1	P1	$M_{S,(4)}$	4)	
								H2	F2	R2	P2			

a) *T* = Moulded draught,  $T_{NB}$  = Draught at normal ballast condition,  $T_{HB}$  = Draught at heavy ballast condition  
 b)  $M_{S,(1)}$ ,  $M_{S,(2)}$ ,  $M_{S,(3)}$ ,  $M_{S,(4)}$  = Still water vertical bending moment as defined in [3.2.2] of Ch 8, Sec 3

Remarks

- 1)  $M_H/V_H$  is to be used as cargo density for calculation of dry cargo pressure.
- 2) Cargo density 3.0 t/m<sup>3</sup> is to be used for calculation of dry cargo pressure in principle.
- 3) This condition is to be applied only for the loaded hold which is not assigned as ballast hold. Position of ballast hold is to be adjusted as appropriate.
- 4) This condition is to be applied only for the loaded hold which is assigned as ballast hold.

**Table 3 Fatigue Assessment applicable to BC-B, BC-C**

No.	Description	Draught <sup>a)</sup>	Loading pattern	Fore			Load case (Design wave)			Still water vertical bending moment <sub>b)</sub>	Remarks (see below)
				Aft	Mid	Fore	H1	R1	P1		
1	Full Load	$T$					H1	R1	P1	$M_{S,(1)}$	1)
							H2	R2	P2		
2	Normal Ballast	$T_{NB}$					H1	R1	P1	$M_{S,(3)}$	
							H2	R2	P2		
3	Heavy Ballast	$T_{HB}$					H1	R1	P1	$M_{S,(4)}$	2)
							H2	R2	P2		
							H1	R1	P1	$M_{S,(4)}$	3)
							H2	R2	P2		

a)  $T$  = Moulded draught,  $T_{NB}$  = Draught at normal ballast condition,  $T_{HB}$  = Draught at heavy ballast condition

b)  $M_{S,(1)}$ ,  $M_{S,(2)}$ ,  $M_{S,(3)}$ ,  $M_{S,(4)}$  = Still water vertical bending moment as defined in [3.2.2] of Ch 8, Sec 3

Remarks

- 1)  $M_H/V_H$  is to be used as cargo density for calculation of dry cargo pressure.
- 2) This condition is to be applied only for the mid-hold which is not assigned as ballast hold. Position of ballast hold is to be adjusted as appropriate.
- 3) This condition is to be applied only for the mid-hold which is assigned as ballast hold.



# **Chapter 5**

## **Hull Girder Strength**

---

Section 1 Yielding Check

Section 2 Ultimate Strength Check

Appendix 1 Hull Girder Ultimate Strength



## SECTION 1 YIELDING CHECK

### Symbols

For symbols not defined in this Section, refer to Ch 1, Sec 4.

$M_{SW}$	= Design still water bending moment in intact condition, in kN.m, at the hull transverse section considered, defined in Ch 4, Sec 3, [2.2]: $M_{SW} = M_{SW,H}$ in hogging conditions $M_{SW} = M_{SW,S}$ in sagging conditions
$M_{WV}$	= Vertical wave bending moment in intact condition, in kN.m, at the hull transverse section considered, defined in Ch 4, Sec 3, [3.1]
$M_{SW,F}$	= Still water bending moment, in kN.m, in flooded conditions, at the hull transverse section under consideration, to be calculated according to Ch 4, Sec 3
$M_{WV,F}$	= Vertical wave bending moment, in kN.m, in flooded conditions, at the hull transverse section under consideration, to be calculated according to Ch 4, Sec 3
$M_{WV,P}$	= Vertical wave bending moment, in kN.m, in harbour conditions, at the hull transverse section under consideration, to be calculated according to Ch 4, Sec 3
$M_{WH}$	= Horizontal wave bending moment, in kN.m, at the hull transverse section considered, defined in Ch 4, Sec 3, [3.3]
$Q_{SW}$	= Design still water shear force in intact condition, in kN, at the hull transverse section considered, defined in Ch 4, Sec 3, [2.3]
$Q_{WV}$	= Vertical wave shear force in intact condition, in kN, at the hull transverse section considered, defined in Ch 4, Sec 3, [3.2]
$Q_{SW,F}$	= Still water shear force, in kN, in flooded conditions, at the hull transverse section under consideration, to be calculated according to Ch 4, Sec 3
$Q_{WV,F}$	= Vertical wave shear force, in kN, in flooded conditions, at the hull transverse section under consideration, to be calculated according to Ch 4, Sec 3
$Q_{WV,P}$	= Vertical wave shear force, in kN, in harbour conditions, at the hull transverse section under consideration, to be calculated according to Ch 4, Sec 3
$k$	= Material factor, as defined in Ch 1, Sec 4, [2.2.1]
$x$	= $X$ co-ordinate, in m, of the calculation point with respect to the reference co-ordinate system defined in Ch 1, Sec 4, [4]
$z$	= $Z$ co-ordinate, in m, of the calculation point with respect to the reference co-ordinate system defined in Ch 1, Sec 4, [4]
$N$	= $Z$ co-ordinate, in m, of the centre of gravity of the hull transverse section defined in [1.2], with respect to the reference co-ordinate system defined in Ch 1, Sec 4, [4]
$V_D$	= Vertical distance, in m, defined in [1.4.2]
$I_Y$	= Net moment of inertia, in $m^4$ , of the hull transverse section about its horizontal neutral axis, to be calculated according to [1.5]
$I_Z$	= Net moment of inertia, in $m^4$ , of the hull transverse section about its vertical neutral axis, to be calculated according to [1.5]
$S$	= Net first moment, in $m^3$ , of the hull transverse section, to be calculated according to [1.6]
$Z_A$	= Net section modulus, in $m^3$ , at any point of the hull transverse section, to be calculated according [1.4.1]
$Z_{AB}, Z_{AD}$	= Net section moduli, in $m^3$ , at bottom and deck, respectively, to be calculated according to [1.4.2]
$C$	= Wave parameter defined in Ch 1, Sec 4, [2.3.1]
$\sigma_{1,ALL}$	= Allowable normal stress, in $N/mm^2$ , defined in [3.1.1]
$\tau_{1,ALL}$	= Allowable shear stress, in $N/mm^2$ , defined in [3.2.1]
$\rho$	= Sea water density, taken equal to $1.025 t/m^3$ .

## 1 Strength characteristics of the hull girder transverse sections

### 1.1 General

#### 1.1.1

This Article specifies the criteria for calculating the hull girder strength characteristics to be used for the checks in [2] to [5], in association with the hull girder loads specified in Ch 4, Sec 3.

## 1.2 Hull girder transverse sections

### 1.2.1 General

Hull girder transverse sections are to be considered as being constituted by the members contributing to the hull girder longitudinal strength, i.e. all continuous longitudinal members below and including the strength deck defined in [1.3], taking into account the requirements in [1.2.2] to [1.2.9].

These members are to be considered as having (see also Ch 3, Sec 2) net offered scantlings based on gross offered thickness reduced by  $0.5t_C$ , when the hull girder strength characteristics are used for:

- the hull girder yielding check according to [2] to [5]
- the ultimate strength check in Ch 5, Sec 2
- the calculation of the hull girder stresses for the strength checks of plating, ordinary stiffeners and primary supporting members according to Ch 6.

### 1.2.2 Continuous trunks and continuous longitudinal hatch coamings

Continuous trunks and continuous longitudinal hatch coamings may be included in the hull girder transverse sections, provided they are effectively supported by longitudinal bulkheads or primary supporting members.

### 1.2.3 Longitudinal ordinary stiffeners or girders welded above the strength deck

Longitudinal ordinary stiffeners or girders welded above the strength deck (including the deck of any trunk fitted as specified in [1.2.2]) are to be included in the hull girder transverse sections.

### 1.2.4 Longitudinal girders between hatchways, supported by longitudinal bulkheads

Where longitudinal girders, effectively supported by longitudinal bulkheads, are fitted between hatchways, the sectional area of these longitudinal girders are to be included in the hull girder transverse.

### 1.2.5 Longitudinal bulkheads with vertical corrugations

Longitudinal bulkheads with vertical corrugations are not to be included in the hull girder transverse sections.

### 1.2.6 Members in materials other than steel

Where a member contributing to the longitudinal strength is made in material other than steel with a Young's modulus  $E$  equal to  $2.06 \cdot 10^5$  N/mm<sup>2</sup>, the steel equivalent sectional area that may be included in the hull girder transverse sections is obtained, in m<sup>2</sup>, from the following formula:

$$A_{SE} = \frac{E}{2.06 \cdot 10^5} A_M$$

where:

$A_M$  = Sectional area, in m<sup>2</sup>, of the member under consideration.

### 1.2.7 Large openings

Large openings are:

- elliptical openings exceeding 2.5 m in length or 1.2 m in breadth
- circular openings exceeding 0.9 m in diameter.

Large openings and scallops, where scallop welding is applied, are always to be deducted from the sectional areas included in the hull girder transverse sections.

### 1.2.8 Small openings

Smaller openings than those in [1.2.7] in one transverse section in the strength deck or bottom area need not be deducted from the sectional areas included in the hull girder transverse sections, provided that:

$$\Sigma b_S \leq 0.06(B - \Sigma b)$$

where:

$\Sigma b_S$  = Total breadth of small openings, in m, in the strength deck or bottom area at the transverse section considered, determined as indicated in Fig 1

$\Sigma b$  = Total breadth of large openings, in m, at the transverse section considered, determined as indicated in Fig 1.

Where the total breadth of small openings  $\Sigma b_S$  does not fulfil the above criteria, only the excess of breadth is

to be deducted from the sectional areas included in the hull girder transverse sections.

### 1.2.9 Lightning holes, draining holes and single scallops

Lightening holes, draining holes and single scallops in longitudinals need not be deducted if their height is less than  $0.25h_w$ , without being greater than 75 mm, where  $h_w$  is the web height, in mm.

Otherwise, the excess is to be deducted from the sectional area or compensated.

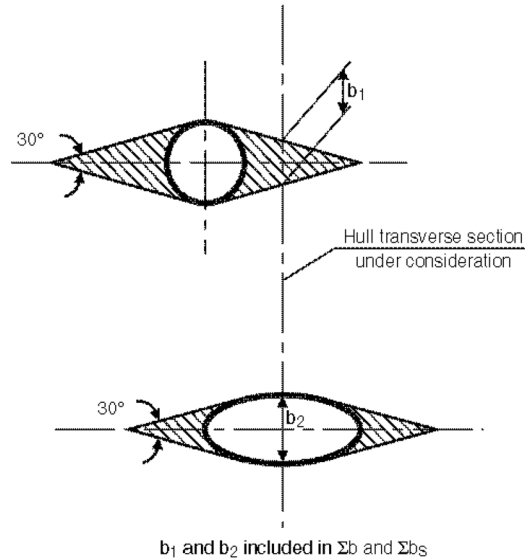

**Fig. 1**  
Calculation of  $\Sigma b$  and  $\Sigma b_s$

## 1.3 Strength deck

### 1.3.1

The strength deck is, in general, the uppermost continuous deck.

In the case of a superstructure or deckhouses contributing to the longitudinal strength, the strength deck is the deck of the superstructure or the deck of the uppermost deckhouse.

### 1.3.2

A superstructure extending at least  $0.15L$  within  $0.4L$  amidships may generally be considered as contributing to the longitudinal strength.

For other superstructures and for deckhouses, their contribution to the longitudinal strength is to be assessed on a case by case basis, to evaluate their percentage of participation to the longitudinal strength.

## 1.4 Section modulus

### 1.4.1

The section modulus at any point of a hull transverse section is obtained, in  $m^3$ , from the following formula:

$$Z_A = \frac{I_Y}{|z - N|}$$

### 1.4.2

The section moduli at bottom and at deck are obtained, in  $m^3$ , from the following formulae:

— at bottom:

$$Z_{AB} = \frac{I_Y}{N}$$

— at deck:

$$Z_{AD} = \frac{I_Y}{V_D}$$

where:

$V_D$  = Vertical distance, in m, taken equal to:

— in general:

$$V_D = z_D - N$$

where:

$z_D$  =  $Z$  co-ordinate, in m, of strength deck at side, defined in [1.3], with respect to the reference co-ordinate system defined in Ch 1, Sec 4, [4]

— if continuous trunks or hatch coamings are taken into account in the calculation of  $I_Y$ , as specified in [1.2.2]:

$$V_D = (z_T - N) \left( 0.9 + 0.2 \frac{y_T}{B} \right) \geq z_D - N$$

where:

$y_T, z_T$  =  $Y$  and  $Z$  co-ordinates, in m, of the top of continuous trunk or hatch coaming with respect to the reference co-ordinate system defined in Ch 1, Sec 4, [4];  $y_T$  and  $z_T$  are to be measured for the point which maximises the value of  $V_D$

— if longitudinal ordinary stiffeners or girders welded above the strength deck are taken into account in the calculation of  $I_Y$ , as specified in [1.2.3],  $V_D$  is to be obtained from the formula given above for continuous trunks and hatch coamings. In this case,  $y_T$  and  $z_T$  are the  $Y$  and  $Z$  co-ordinates, in m, of the top of the longitudinal stiffeners or girders with respect to the reference co-ordinate system defined in Ch 1, Sec 4, [4].

## 1.5 Moments of inertia

### 1.5.1

The moments of inertia  $I_Y$  and  $I_Z$ , in  $m^4$ , are those, calculated about the horizontal and vertical neutral axes, respectively, of the hull transverse sections defined in [1.2].

## 1.6 First moment

### 1.6.1

The first moment  $S$ , in  $m^3$ , at a level  $z$  above the baseline is that, calculated with respect to the horizontal neutral axis, of the portion of the hull transverse sections defined in [1.2] located above the  $z$  level.

## 2 Hull girder stresses

### 2.1 Normal stresses

#### 2.1.1 General

The normal stresses in a member made in material other than steel with a Young's modulus  $E$  equal to  $2.06 \cdot 10^5$  N/mm<sup>2</sup>, included in the hull girder transverse sections as specified in [1.2.6], are obtained from the following formula:

$$\sigma_1 = \frac{E}{2.06 \cdot 10^5} \sigma_{1S}$$

where:

$\sigma_{1S}$  = Normal stress, in N/mm<sup>2</sup>, in the member under consideration, calculated according to [2.1.2] and [2.1.3] considering this member as having the steel equivalent sectional area  $A_{SE}$  defined in [1.2.6].

### 2.1.2 Normal stresses induced by vertical bending moments

The normal stresses induced by vertical bending moments are obtained, in N/mm<sup>2</sup>, from the following formulae:

— at any point of the hull transverse section, located below  $z_{VD}$ , where  $z_{VD} = V_D + N$ :

$$\sigma_1 = \frac{M_{SW} + M_{WV}}{Z_A} 10^{-3}$$

— at bottom:

$$\sigma_1 = \frac{M_{SW} + M_{WV}}{Z_{AB}} 10^{-3}$$

— at deck:

$$\sigma_1 = \frac{M_{SW} + M_{WV}}{Z_{AD}} 10^{-3}$$

### 2.1.3 Normal stresses in flooded conditions of BC-A or BC-B ships

This requirement applies to **BC-A** or **BC-B** ships, in addition to [2.1.2].

The normal stresses, in the flooded conditions specified in Ch 4, Sec 3, are to be obtained at any point, in N/mm<sup>2</sup>, from the following formula:

$$\sigma_1 = \frac{M_{SW,F} + M_{WV,F}}{Z_A} 10^{-3}$$

## 2.2 Shear stresses

### 2.2.1 General

The shear stresses induced by vertical shear forces  $Q_{SW}$  and  $Q_{WV}$  in intact condition and, for **BC-A** and **BC-B** ships by vertical shear forces  $Q_{SW,F}$  and  $Q_{WV,F}$  in flooded condition are normally to be obtained through direct analyses.

When they are combined, vertical shear forces  $Q_{SW}$  and  $Q_{WV}$  in intact condition are to be taken with the same sign. The same is to be applied also for combination of vertical shear forces  $Q_{SW,F}$  and  $Q_{WV,F}$  in flooded condition.

The shear force correction  $\Delta Q_C$  is to be taken into account, in accordance with [2.2.2]. The shear force correction need not to be considered at the fore end of foremost hold and aft end of aftermost hold.

As an alternative to this procedure, the shear stresses induced by the vertical shear forces  $Q_{SW}$  and  $Q_{WV}$  in intact condition and, for **BC-A** and **BC-B** ships by the vertical shear forces  $Q_{SW,F}$  and  $Q_{WV,F}$  in flooded condition may be obtained through the simplified procedure in [2.2.2] and [2.2.3] respectively.

### 2.2.2 Simplified calculation of shear stresses induced by vertical shear forces

The shear stresses induced by the vertical shear forces in the calculation point are obtained, in N/mm<sup>2</sup>, from the following formula:

$$\tau_1 = (Q_{SW} + Q_{WV} - \varepsilon \Delta Q_C) \frac{S}{I_y t} \delta$$

where:

$t$  = Minimum net thickness, in mm, of side and inner side plating, as applicable according to Table 1

$\delta$  = Shear distribution coefficient defined in Table 1

$$\varepsilon = \text{sgn}(Q_{SW})$$

$\Delta Q_C$  = Shear force correction (see Fig 2), at the section considered. The shear force correction is to be considered independently forward and aft of the transverse bulkhead for the hold considered. The shear force correction takes into account, when applicable, the portion of loads transmitted by the double bottom girders to the transverse bulkheads:

— for ships with any non-homogeneous loading conditions, such as alternate hold loading

conditions and heavy ballast conditions carrying ballast in hold(s):

$$\Delta Q_C = \alpha \left| \frac{M}{B_H \ell_H} - \rho T_{LC,mh} \right|$$

for each non-homogeneous loading condition

— for other ships and homogeneous loading conditions:

$$\Delta Q_C = 0$$

$$\varphi = 1.38 + 1.55 \frac{\ell_0}{b_0}, \text{ to be taken not greater than } 3.7$$

$$\alpha = g \frac{\ell_0 b_0}{2 + \varphi \frac{\ell_0}{b_0}}$$

$\ell_0, b_0$  = Length and breadth, respectively, in m, of the flat portion of the double bottom in way of the hold considered;  $b_0$  is to be measured on the hull transverse section at the middle of the hold

$\ell_H$  = Length, in m, of the hold considered, measured between the middle of the transverse corrugated bulkheads depth

$B_H$  = Ship's breadth, in m, measured at the level of inner bottom on the hull transverse section at the middle of the hold considered

$M$  = Mass, in t, in the considered section.

— Adjacent cargo hold is loaded in a non homogeneous loading condition for the condition under consideration

$M$  is to include the total mass in the hold and the mass of water ballast in double bottom tank, bounded by side girders in way of hopper tank plating or longitudinal bulkhead.

— Other cases

$M$  is the total mass in the hold.

$T_{LC,mh}$  = Draught, in m, measured vertically on the hull transverse section at the middle of the hold considered, from the moulded baseline to the waterline in the loading condition considered.

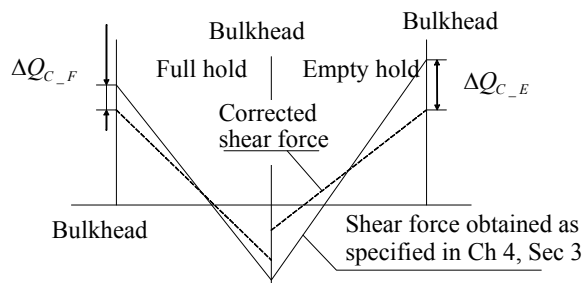

$\Delta Q_{C\_F}$  : shear force correction for the full hold

$\Delta Q_{C\_E}$  : shear force correction for the empty hold

**Fig. 2**  
Shear force correction  $\Delta Q_C$

Table 1 Shear stresses induced by vertical shear forces			
Ship typology	Location	t (mm)	$\delta$



Single side ship	Sides	$t_S$	0.5
Double side ship	Sides	$t_S$	$0.5(1 - \phi)$
	Inner sides	$t_{IS}$	$0.5\phi$

where:

$t_S, t_{IS}$  = Minimum net thicknesses, in mm, of side and inner side, respectively  
 $t_{SM}, t_{ISM}$  = Mean net thicknesses, in mm, over all the strakes of side and inner side, respectively. They are calculated as  $\Sigma(\lambda_i t_i) / \Sigma \lambda_i$ , where  $\lambda_i$  and  $t_i$  are the length, in m, and the net thickness, in mm, of the  $i^{\text{th}}$  strake of side and inner side.  
 $\phi$  = Coefficient taken equal to:

$$\phi = 0.275 + 0.25 \frac{t_{ISM}}{t_{SM}}$$

### 2.2.3 Shear stresses in flooded conditions of BC-A or BC-B ships

This requirement applies to **BC-A** or **BC-B** ships, in addition to [2.2.1] and [2.2.2].

The shear stresses, in the flooded conditions specified in Ch 4, Sec 3, are to be obtained at the calculation point, in N/mm<sup>2</sup>, from the following formula:

$$\tau_1 = (Q_{SW,F} + Q_{WV,F} - \varepsilon \Delta Q_C) \frac{S}{I_y t} \delta$$

$$\varepsilon = \text{sgn}(Q_{SW,F})$$

$\Delta Q_C$  = Shear force correction, to be calculated according to [2.2.2], where the mass of the ingressed water is to be added to  $M$  and where the draught  $T_{LC,mh}$  is to be measured up to the equilibrium waterline  
 $t$  = Net thickness, in mm, of the side plating.

## 3 Checking criteria

### 3.1 Normal stresses

#### 3.1.1

It is to be checked that the normal stresses  $\sigma_1$  calculated according to [2.1.2] and, when applicable, [2.1.3] are in compliance with the following formula:

$$\sigma_1 \leq \sigma_{1,ALL}$$

where:

$\sigma_{1,ALL}$  = Allowable normal stress, in N/mm<sup>2</sup>, obtained from the following formulae:

$$\begin{aligned} \sigma_{1,ALL} &= \frac{130}{k} && \text{for } \frac{x}{L} \leq 0.1 \\ \sigma_{1,ALL} &= \frac{190}{k} - \frac{1500}{k} \left( \frac{x}{L} - 0.3 \right)^2 && \text{for } 0.1 < \frac{x}{L} < 0.3 \\ \sigma_{1,ALL} &= \frac{190}{k} && \text{for } 0.3 \leq \frac{x}{L} \leq 0.7 \\ \sigma_{1,ALL} &= \frac{190}{k} - \frac{1500}{k} \left( \frac{x}{L} - 0.7 \right)^2 && \text{for } 0.7 < \frac{x}{L} < 0.9 \\ \sigma_{1,ALL} &= \frac{130}{k} && \text{for } \frac{x}{L} \geq 0.9 \end{aligned}$$

### 3.2 Shear stresses

#### 3.2.1

It is to be checked that the shear stresses  $\tau_1$  calculated according to [2.2.1] or [2.2.2] and, when applicable, [2.2.3] are in compliance with the following formula:

$$\tau_1 \leq \tau_{1,ALL}$$

where:

$\tau_{1,ALL}$  = Allowable shear stress, in N/mm<sup>2</sup>:

$$\tau_{1,ALL} = 120/k$$

## 4 Section modulus and moment of inertia

### 4.1 General

#### 4.1.1

The requirements in [4.2] to [4.5] provide the minimum hull net girder section modulus, complying with the checking criteria indicated in [3], and the midship net section moment of inertia required to ensure sufficient hull girder rigidity.

#### 4.1.2

The  $k$  material factors are to be defined with respect to the materials used for the bottom and deck members contributing to the longitudinal strength according to [1]. When material factors for higher strength steels are used, the requirements in [4.5] apply.

### 4.2 Section modulus within 0.4L amidships

#### 4.2.1

The net section moduli  $Z_{AB}$  and  $Z_{AD}$  at the midship section are to be not less than the value obtained, in m<sup>3</sup>, from the following formula:

$$Z_{R,MIN} = 0.9CL^2 B(C_B + 0.7)k 10^{-6}$$

#### 4.2.2

In addition, the net section moduli  $Z_{AB}$  and  $Z_{AD}$  within 0.4L amidships are to be not less than the value obtained, in m<sup>3</sup>, from the following formula:

$$Z_R = \frac{M_{SW} + M_{WV}}{\sigma_{1,ALL}} 10^{-3}$$

in addition, for **BC-A** and **BC-B** ships:

$$Z_R = \frac{M_{SW,F} + M_{WV,F}}{\sigma_{1,ALL}} 10^{-3}$$

#### 4.2.3

Where the total breadth  $\Sigma b_S$  of small openings, as defined in [1.2.8], is deducted from the sectional areas included in the hull girder transverse sections, the values  $Z_{R,MIN}$  and  $Z_R$  defined in [4.2.1] or [4.2.2] may be reduced by 3%.

#### 4.2.4

Scantlings of members contributing to the longitudinal strength (see [1]), based on the section modulus requirement in [4.2.1], are to be maintained within 0.4L amidships.

### 4.3 Section modulus outside 0.4L amidships

#### 4.3.1

The net section moduli  $Z_{AB}$  and  $Z_{AD}$  outside 0.4L amidships are to be not less than the value obtained, in m<sup>3</sup>, from the following formula:

$$Z_R = \frac{M_{SW} + M_{WV}}{\sigma_{1,ALL}} 10^{-3}$$

in addition, for **BC-A** and **BC-B** ships:

$$Z_R = \frac{M_{SW,F} + M_{WV,F}}{\sigma_{1,ALL}} 10^{-3}$$

### 4.3.2

Scantlings of members contributing to the hull girder longitudinal strength (see [1]) may be gradually reduced, outside  $0.4L$  amidships, to the minimum required for local strength purposes at fore and aft parts, as specified in Ch 9, Sec 1 or Ch 9, Sec 2, respectively.

## 4.4 Midship section moment of inertia

### 4.4.1

The net midship section moment of inertia about its horizontal neutral axis is to be not less than the value obtained, in  $m^4$ , from the following formula:

$$I_{YR} = 3Z'_{R,MIN} L \cdot 10^{-2}$$

where  $Z'_{R,MIN}$  is the required net midship section modulus  $Z_{R,MIN}$ , in  $m^3$ , calculated as specified in [4.2.1] but assuming  $k = 1$ .

## 4.5 Extent of higher strength steel

### 4.5.1

When a material factor for higher strength steel is used in calculating the required section modulus at bottom or deck according to [4.2] or [4.3], the relevant higher strength steel is to be adopted for all members contributing to the longitudinal strength (see [1]), at least up to a vertical distance, in m, obtained from the following formulae:

— above the baseline (for section modulus at bottom):

$$V_{HB} = \frac{\sigma_{1B} - k\sigma_{1,ALL}}{\sigma_{1B} + \sigma_{1D}} z_D$$

— below a horizontal line located at a distance  $V_D$  (see [1.4.2]) above the neutral axis of the hull transverse section (for section modulus at deck):

$$V_{HD} = \frac{\sigma_{1D} - k\sigma_{1,ALL}}{\sigma_{1B} + \sigma_{1D}} (N + V_D)$$

where:

$\sigma_{1B}$ ,  $\sigma_{1D}$  = Normal stresses, in  $N/mm^2$ , at bottom and deck, respectively, calculated according to [2.1]  
 $z_D$  =  $Z$  co-ordinate, in m, of the strength deck defined in [1.3], with respect to the reference co-ordinate system defined in Ch 1, Sec 4, [4].

### 4.5.2

The higher strength steel is to extend in length at least throughout  $0.4L$  amidships where it is required for strength purposes according to the provision of the present Rules.

## 5 Permissible still water bending moment and shear force

### 5.1 Permissible still water bending moment and shear force in intact condition

#### 5.1.1 Permissible still water bending moment

The permissible still water bending moment at any hull transverse section in intact condition, in hogging or sagging conditions, is the value  $M_{SW}$  considered in the hull girder section modulus calculation according to [4.2] and [4.3].

In the case of structural discontinuities in the hull transverse sections, the distribution of permissible still water bending moments is considered on a case by case basis.

### 5.1.2 Permissible still water shear force - Direct calculation

Where the shear stresses are obtained through calculation analyses according to [2.2.1], the permissible positive or negative still water shear force in intact condition at any hull transverse section is obtained, in kN, from the following formula:

$$Q_P = \varepsilon |Q_T| - Q_{WV}$$

where:

$$\varepsilon = \text{sgn}(Q_{SW})$$

$Q_T$  = Shear force, in kN, which produces a shear stress  $\tau = 120/k \text{ N/mm}^2$  in the most stressed point of the hull net transverse section, taking into account the shear force correction  $\Delta Q_C$  in accordance with [2.2.2].

A lower value of the permissible still water shear force may be considered, if requested by the Shipbuilder.

### 5.1.3 Permissible still water shear force - Simplified calculation

Where the shear stresses are obtained through the simplified procedure in [2.2.2], the permissible positive or negative still water shear force in intact condition at any hull transverse section is obtained, in kN, from the following formula:

$$Q_P = \varepsilon \left( \frac{120}{k\delta} \frac{I_y t}{S} + \Delta Q_C \right) - Q_{WV}$$

where:

$$\varepsilon = \text{sgn}(Q_{SW})$$

$\delta$  = Shear distribution coefficient defined in Table 1

$t$  = Minimum net thickness, in mm, of side and inner side plating, as applicable according to Table 1

$\Delta Q_C$  = Shear force corrections defined in [2.2.2], to be considered independently forward and aft of the transverse bulkhead.

A lower value of the permissible still water shear force may be considered, if requested by the Shipbuilder.

## 5.2 Permissible still water bending moment and shear force in harbour conditions

### 5.2.1 Permissible still water bending moment

The permissible still water bending moment at any hull transverse section in harbour conditions, in hogging or sagging conditions, is obtained, in kN.m, from the following formula:

$$M_{P,P} = M_{SW} + M_{WV} - M_{WV,P}$$

A lower value of the permissible still water bending moment in harbour conditions may be considered, if requested by the Shipbuilder.

### 5.2.2 Permissible still water shear force

The permissible positive or negative still water shear force at any hull transverse section, in harbour conditions, is obtained, in kN, from the following formula:

$$Q_{P,P} = \varepsilon Q_P + Q_{WV} - Q_{WV,P}$$

where:

$$\varepsilon = \text{sgn}(Q_{SW})$$

$Q_P$  = Permissible still water shear force during navigation, in kN, to be calculated according to [5.1.3].

A lower value of the permissible still water shear force in harbour conditions may be considered, if requested by the Shipbuilder.

## 5.3 Permissible still water bending moment and shear force in flooded condition

### 5.3.1 Permissible still water bending moment

The permissible still water bending moment at any hull transverse section in flooded condition, in hogging or

sagging conditions, is the value  $M_{SW,F}$  considered in the hull girder section modulus calculation according to [4.2] and [4.3].

In the case of structural discontinuities in the hull transverse sections, the distribution of permissible still water bending moments is considered on a case by case basis.

### 5.3.2 Permissible still water shear force - Direct calculation

Where the shear stresses are obtained through calculation analyses according to [2.2.1], the permissible positive or negative still water shear force in flooded condition at any hull transverse section is obtained, in kN, from the following formula:

$$Q_{P,F} = \varepsilon |Q_T| - Q_{WV,F}$$

where:

$$\varepsilon = \text{sgn}(Q_{SW,F})$$

$Q_T$  = Shear force, in kN, which produces a shear stress  $\tau = 120/k \text{ N/mm}^2$  in the most stressed point of the hull net transverse section, taking into account the shear force correction  $\Delta Q_C$  in accordance with [2.2.2].

### 5.3.3 Permissible still water shear force - Simplified calculation

Where the shear stresses are obtained through the simplified procedure in [2.2.2], the permissible positive or negative still water shear force in flooded condition at any hull transverse section is obtained, in kN, from the following formula:

$$Q_{P,F} = \varepsilon \left( \frac{120}{k\delta} \frac{I_y t}{S} + \Delta Q_C \right) - Q_{WV,F}$$

where:

$$\varepsilon = \text{sgn}(Q_{SW})$$

$\delta$  = Shear distribution coefficient defined in Table 1

$t$  = Minimum net thickness, in mm, of side and inner side plating, as applicable according to Table 1

$\Delta Q_C$  = Shear force correction, to be calculated according to [2.2.2], where the mass  $M$  is to include the mass of the ingressed water in the hold considered and the draught  $T_{LC}$  is to be measured up to the equilibrium waterline.

## SECTION 2 ULTIMATE STRENGTH CHECK

### 1 Application

#### 1.1 General

##### 1.1.1

The requirements of this Section apply to ships equal to or greater than 150 m in length  $L$ .

### 2 Hull girder ultimate strength check

#### 2.1 Hull girder loads

##### 2.1.1 Bending moment

The bending moment  $M$  in sagging and hogging conditions, to be considered in the ultimate strength check of the hull girder, is to be obtained, in kN.m, in intact, flooded and harbour conditions, from the following formula:

$$M = M_{SW} + \gamma_W M_{WV}$$

where:

- $M_{SW}, M_{SW,F}, M_{SW,P}$  = Design still water bending moment, in kN.m, in sagging and hogging conditions at the hull transverse section considered, to be calculated respectively in intact ( $M_{SW}$ ), flooded ( $M_{SW,F}$ ) and harbour ( $M_{SW,P}$ ) conditions
- $M_{WV}, M_{WV,F}, M_{WV,P}$  = Vertical wave bending moment, in kN.m, in sagging and hogging conditions at the hull transverse section considered, defined in Ch 4, Sec 3, respectively in intact ( $M_{WV}$ ), flooded ( $M_{WV,F}$ ) and harbour ( $M_{WV,P}$ ) conditions
- $\gamma_W$  = Safety factor on wave hull girder bending moments, taken equal to:  
 $\gamma_W = 1.20$

#### 2.2 Hull girder bending moment

##### 2.2.1 Curve M- $\chi$

The ultimate bending moment capacities of a hull girder transverse section, in hogging and sagging conditions, are defined as the maximum values of the curve of bending moment capacity  $M$  versus the curvature  $\chi$  of the transverse section considered (see Fig 1).

The curvature  $\chi$  is positive for hogging condition and negative for sagging condition.

The curve  $M$ - $\chi$  is to be obtained through an incremental-iterative procedure, according to the criteria specified in App 1.

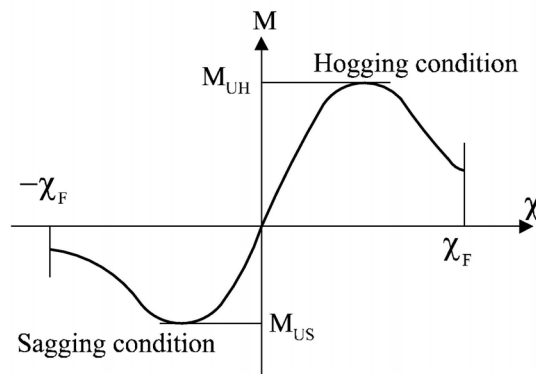

**Fig. 1**  
Curve bending moment capacity  $M$  versus curvature  $\chi$

### 2.2.2 Hull girder transverse sections

The hull girder transverse sections are constituted by the elements contributing to the hull girder longitudinal strength, considered with their net offered scantlings according to Ch 3, Sec 2, [3.2.4].

## 2.3 Checking criteria

### 2.3.1

It is to be checked that the hull girder ultimate bending capacity at any hull transverse section is in compliance with the following formula:

$$M \leq \frac{M_U}{\gamma_R}$$

where:

$M_U$  = Ultimate bending moment capacity of the hull transverse section considered, calculated with net offered scantlings based on gross offered thickness reduced by  $0.5 t_C$ , in kN.m:

$M_U = M_{UH}$  in hogging conditions

$M_U = M_{US}$  in sagging conditions

$M_{UH}$  = Ultimate bending moment capacity in hogging conditions, in kN.m, defined in [2.2.1]

$M_{US}$  = Ultimate bending moment capacity in sagging conditions, in kN.m, defined in [2.2.1]

$M$  = Bending moment, in kN.m, defined in [2.1.1] for the ship in intact, flooded and harbour conditions

$\gamma_R$  = Safety factor taken equal to 1.10.

## APPENDIX 1 HULL GIRDER ULTIMATE STRENGTH

### Symbols

For symbols not defined in this Appendix, refer to Ch 1, Sec 4.

$I_Y$	=	Moment of inertia, in $m^4$ , of the hull transverse section around its horizontal neutral axis, to be calculated according to Ch 5, Sec 1, [1.5.1]
$Z_{AB}, Z_{AD}$	=	Section moduli, in $m^3$ , at bottom and deck, respectively, defined in Ch 5, Sec 1, [1.4.2].
$R_{eHs}$	=	Minimum yield stress, in $N/mm^2$ , of the material of the considered stiffener.
$R_{eHp}$	=	Minimum yield stress, in $N/mm^2$ , of the material of the considered plate.
$A_s$	=	Net sectional area, in $cm^2$ , of stiffener, without attached plating.
$A_p$	=	Net sectional area, in $cm^2$ , of attached plating.

## 1 Hull girder ultimate strength check

### 1.1 Introduction

#### 1.1.1

This Appendix provides the criteria for obtaining the curve  $M-\chi$  and the ultimate longitudinal bending moment capacity  $M_U$  that are to be calculated according to the simplified incremental-iterative approach, as specified in [2.1].

## 2 Criteria for the calculation of the curve $M-\chi$

### 2.1 Simplified method based on a incremental-iterative approach

#### 2.1.1 Procedure

The curve  $M-\chi$  is to be obtained by means of an incremental-iterative approach, summarised in the flow chart in Fig 1.

In this approach, the ultimate hull girder bending moment capacity  $M_U$  is defined as the peak value of the curve with vertical bending moment  $M$  versus the curvature  $\chi$  of the ship cross section as shown in Fig 1. The curve is to be obtained through an incremental-iterative approach.

Each step of the incremental procedure is represented by the calculation of the bending moment  $M_i$  which acts on the hull transverse section as the effect of an imposed curvature  $\chi_i$ .

For each step, the value  $\chi_i$  is to be obtained by summing an increment of curvature  $\Delta\chi$  to the value relevant to the previous step  $\chi_{i-1}$ . This increment of curvature corresponds to an increment of the rotation angle of the hull girder transverse section around its horizontal neutral axis.

This rotation increment induces axial strains  $\varepsilon$  in each hull structural element, whose value depends on the position of the element. In hogging condition, the structural elements above the neutral axis are lengthened, while the elements below the neutral axis are shortened. Vice-versa in sagging condition.

The stress  $\sigma$  induced in each structural element by the strain  $\varepsilon$  is to be obtained from the load-end shortening curve  $\sigma-\varepsilon$  of the element, which takes into account the behaviour of the element in the non-linear elasto-plastic domain.

The distribution of the stresses induced in all the elements composing the hull transverse section determines, for each step, a variation of the neutral axis position, since the relationship  $\sigma-\varepsilon$  is non-linear. The new position of the neutral axis relevant to the step considered is to be obtained by means of an iterative process, imposing the equilibrium among the stresses acting in all the hull elements.

Once the position of the neutral axis is known and the relevant stress distribution in the section structural elements is obtained, the bending moment of the section  $M_i$  around the new position of the neutral axis, which corresponds to the curvature  $\chi_i$  imposed in the step considered, is to be obtained by summing the contribution given by each element stress.

The main steps of the incremental-iterative approach described above are summarised as follows (see also Fig



1):

- Step 1** Divide the transverse section of hull into stiffened plate elements.  
**Step 2** Define stress-strain relationships for all elements as shown in Table 1  
**Step 3** Initialize curvature  $\chi_1$  and neutral axis for the first incremental step with the value of incremental curvature (curvature that induces a stress equal to 1% of yield strength in strength deck) as:

$$\chi_1 = \Delta\chi = \frac{0.01 \frac{R_{eH}}{E}}{z_D - N}$$

where:

$z_D$  = Z co-ordinate, in m, of strength deck at side, with respect to reference co-ordinate defined in Ch 1, Sec 4, [4]

- Step 4** Calculate for each element the corresponding strain  $\varepsilon_i = \chi (z_i - z_{NA})$  and the corresponding stress  $\sigma_i$   
**Step 5** Determine the neutral axis  $z_{NA\_cur}$  at each incremental step by establishing force equilibrium over the whole transverse section as:  
 $\sum A_i \sigma_i = \sum A_j \sigma_j$  (i-th element is under compression, j-th element under tension)  
**Step 6** Calculate the corresponding moment by summing the contributions of all elements as:

$$M_U = \sum \sigma_{U_i} A_i (z_i - z_{NA\_cur})$$

- Step 7** Compare the moment in the current incremental step with the moment in the previous incremental step. If the slope in  $M$ - $\chi$  relationship is less than a negative fixed value, terminate the process and define the peak value of  $M_U$ . Otherwise, increase the curvature by the amount of  $D\chi$  and go to Step 4.

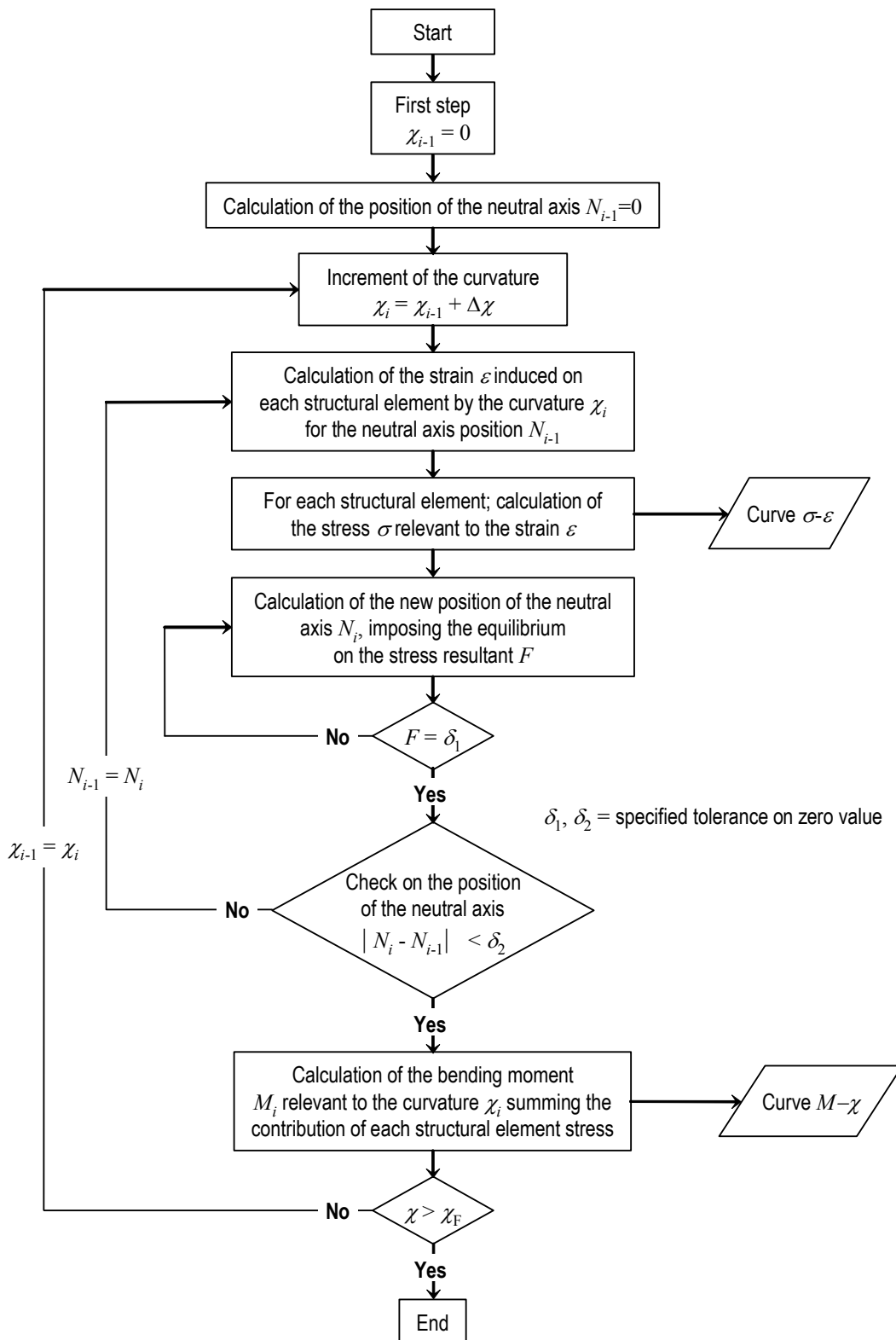

**Fig. 1**  
 Flow chart of the procedure for the evaluation of the curve M- $\chi$

### 2.1.2 Assumption

In applying the procedure described in [2.1.1], the following assumptions are generally to be made:

- the ultimate strength is calculated at hull transverse sections between two adjacent transverse webs.
- the hull girder transverse section remains plane during each curvature increment.
- the hull material has an elasto-plastic behaviour.

— the hull girder transverse section is divided into a set of elements, which are considered to act independently.

These elements are:

- transversely framed plating panels and/or ordinary stiffeners with attached plating, whose structural behaviour is described in [2.2.1]
- hard corners, constituted by plating crossing, whose structural behaviour is described in [2.2.2].

— according to the iterative procedure, the bending moment  $M_i$  acting on the transverse section at each curvature value  $\chi_i$  is obtained by summing the contribution given by the stress  $\sigma$  acting on each element. The stress  $\sigma$ , corresponding to the element strain  $\varepsilon$ , is to be obtained for each curvature increment from the non-linear load-end shortening curves  $\sigma$ - $\varepsilon$  of the element.

These curves are to be calculated, for the failure mechanisms of the element, from the formulae specified in [2.2]. The stress  $\sigma$  is selected as the lowest among the values obtained from each of the considered load-end shortening curves  $\sigma$ - $\varepsilon$ .

— The procedure is to be repeated until the value of the imposed curvature reaches the value  $\chi_F$ , in  $m^{-1}$ , in hogging and sagging condition, obtained from the following formula:

$$\chi_F = \pm 0.003 \frac{M_Y}{EI_Y}$$

where:

$M_Y$  = the lesser of the values  $M_{Y1}$  and  $M_{Y2}$ , in kN.m:

$$M_{Y1} = 10^3 R_{eH} Z_{AB}$$

$$M_{Y2} = 10^3 R_{eH} Z_{AD}$$

If the value  $\chi_F$  is not sufficient to evaluate the peaks of the curve  $M$ - $\chi$ , the procedure is to be repeated until the value of the imposed curvature permits the calculation of the maximum bending moments of the curve.

### 2.1.3 Modeling of the hull girder cross section

Hull girder transverse sections are to be considered as being constituted by the members contributing to the hull girder ultimate strength.

Sniped stiffeners are also to be modeled imaginarily, taking account that they doesn't contribute to the hull girder strength.

The structural members are categorized into an ordinary stiffener element, a stiffened plate element or a hard corner element.

The plate panel including web plate of girder or side stringer is idealized into either a stiffened plate element, an attached plate of an ordinary stiffener element or a hard corner element.

The plate panel is categorized into the following two kinds:

- longitudinally stiffened panel of which the longer side is in the longitudinal direction, and
- transversely stiffened panel of which the longer side is in the perpendicular direction to the longitudinal direction.

— *Hard corner element*

Hard corner elements are sturdier elements composing the hull girder transverse section, which collapse mainly according to an elasto-plastic mode of failure (material yielding); they are generally constituted by two plates not lying in the same plane.

The extent of a hard corner element from the point of intersection of the plates is taken equal to  $20t_p$  on transversely stiffened panel and to  $0.5s$  on a longitudinally stiffened panel. (See Fig 2)

where:

$t_p$  = Gross offered thickness of the plate, in mm

$s$  = Spacing of the adjacent longitudinal stiffener, in m

Bilge, sheer strake-deck stringer elements, girder-deck connections and face plate-web connections on large girders are typical hard corners.

— *Ordinary stiffener element*

The ordinary stiffener constitutes an ordinary stiffener element together with the attached plate.

The attached plate width is in principle:

- equal to the mean spacing of the ordinary stiffener when the panels on both sides of the stiffener are longitudinally stiffened, or
- equal to the width of the longitudinally stiffened panel when the panel on one side of the stiffener is longitudinally stiffened and the other panel is of the transversely stiffened. (See Fig 2).

— *Stiffened plate element*

The plate between ordinary stiffener elements, between an ordinary stiffener element and a hard corner element or between hard corner elements is to be treated as a stiffened plate element. (See Fig 2)

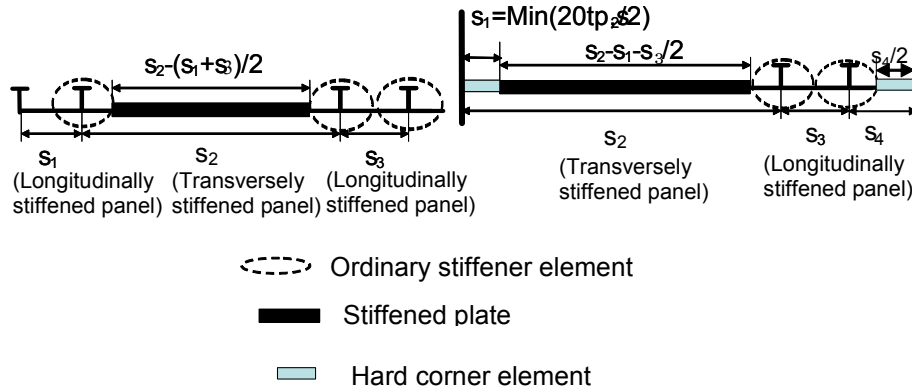

**Fig. 2**  
 Extension of the breadth of the attached plating and hard corner element

The typical examples of modeling of hull girder section are illustrated in Figs 3 and 4.

Notwithstanding the foregoing principle these figures are to be applied to the modeling in the vicinity of upper deck, sheer strake and hatch side girder.

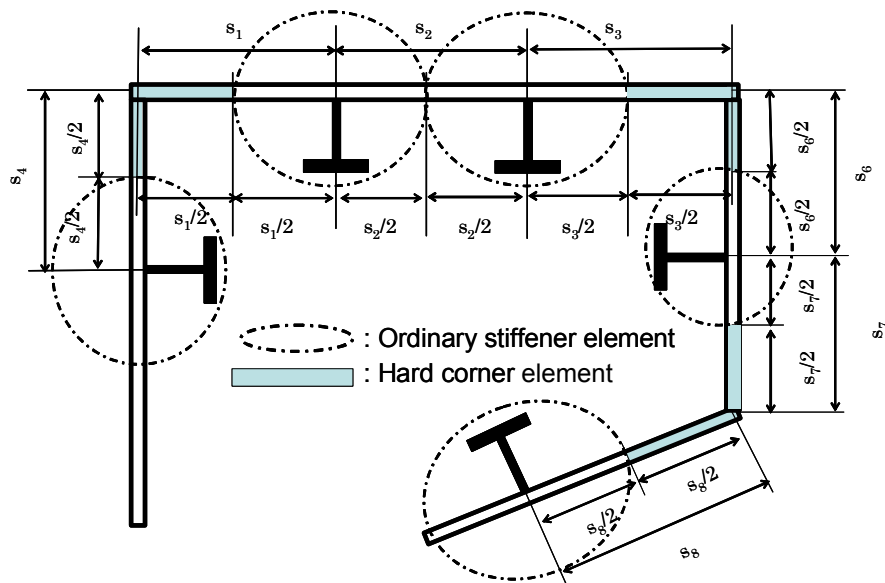

**Fig. 3**  
 Extension of the breadth of the attached plating and hard corner element

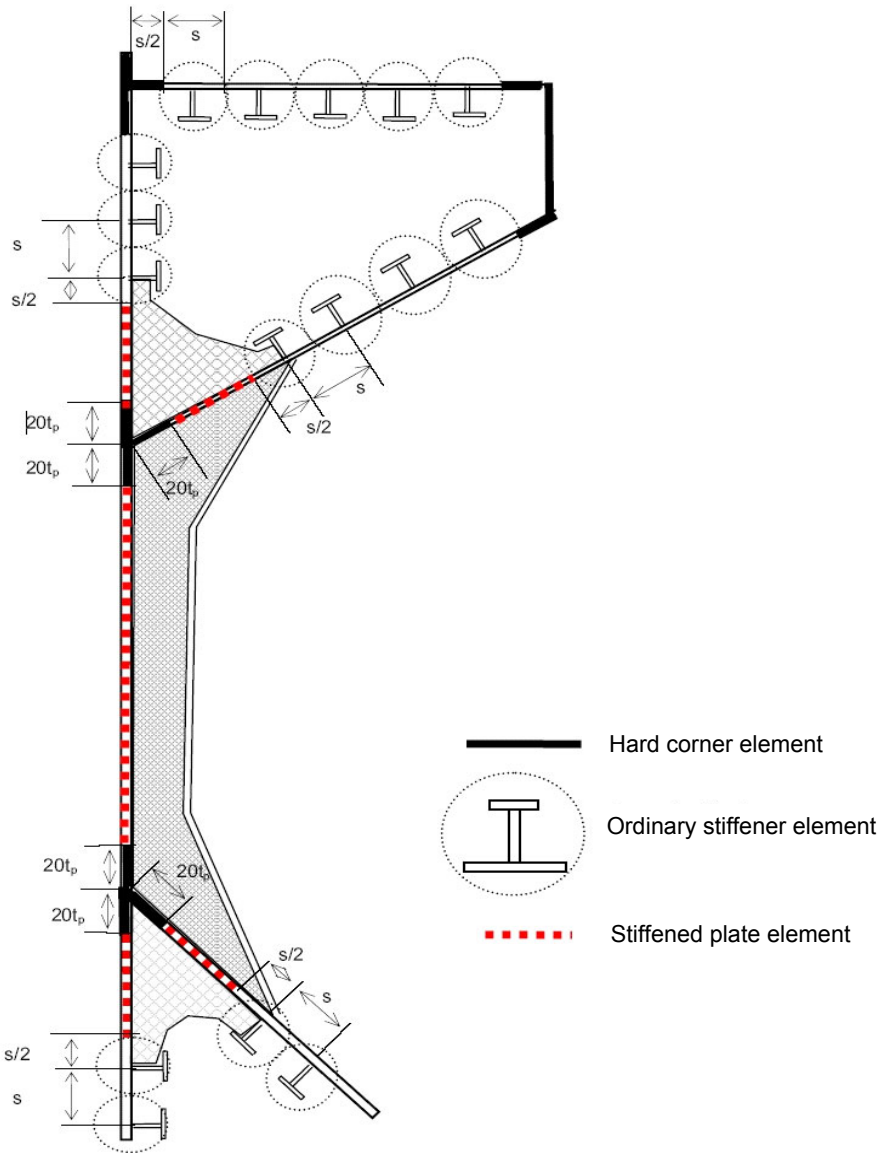

**Fig. 4**  
Examples of the configuration of stiffened plate elements, ordinary stiffener elements and hard corner elements on a hull section

**Notes:**

- 1) In case of the knuckle point as shown in Fig 5, the plating area adjacent to knuckles in the plating with an angle greater than 30 degrees is defined as a hard corner. The extent of one side of the corner is taken equal to  $20t_p$  on transversely framed panels and to  $0.5s$  on longitudinally framed panels from the knuckle point.

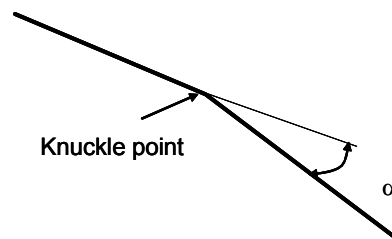

**Fig. 5**  
The case of plating with knuckle point

- 2) Where the plate members are stiffened by non-continuous longitudinal stiffeners, the non-continuous stiffeners are considered only as dividing a plate into various elementary plate panels.

- 3) Where the opening is provided in the stiffened plate element, the openings are to be considered in accordance with Ch 5 Sec 1, [1.2.7], [1.2.8] and [1.2.9].
- 4) Where attached plating is made of steels having different thicknesses and/or yield stresses, an average thickness and/or average yield stress obtained by the following formula are to be used for the calculation.

$$t = \frac{t_1 s_1 + t_2 s_2}{s}, \quad R_{eHp} = \frac{R_{eHp1} t_1 s_1 + R_{eHp2} t_2 s_2}{ts}$$

Where,

$R_{eH1}$ ,  $R_{eH2}$ ,  $t_1$ ,  $t_2$ ,  $s_1$ ,  $s_2$  and  $s$  are shown in Fig 6.

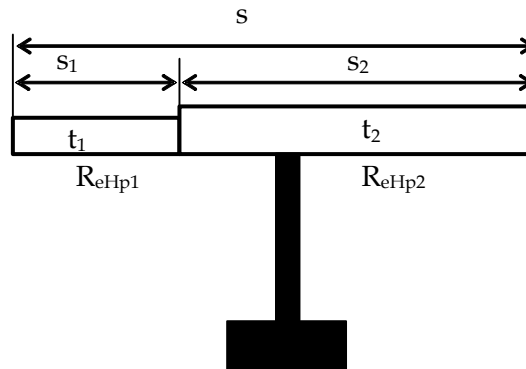

Fig. 6  
Element with different thickness and yield strength

## 2.2 Load-end shortening curves $\sigma$ - $\varepsilon$

### 2.2.1 Stiffened plate element and ordinary stiffener element

Stiffened plate element and ordinary stiffener element composing the hull girder transverse sections may collapse following one of the modes of failure specified in Table 1.

- Where the plate members are stiffened by non-continuous longitudinal stiffeners, the stress of the element is to be obtained in accordance with [2.2.3] to [2.2.7], taking into account the non-continuous longitudinal stiffener.  
In calculating the total forces for checking the hull girder ultimate strength, the area of non-continuous longitudinal stiffener is to be assumed as zero.
- Where the opening is provided in the stiffened plate element, the considered area of the stiffened plate element is to be obtained by deducting the opening area from the plating in calculating the total forces for checking the hull girder ultimate strength. The consideration of the opening is in accordance with the requirement in Ch.5 Sec.1, [1.2.7] to [1.2.9].
- For stiffened plate element, the effective breadth of plate for the load shortening portion of the stress-strain curve is to be taken as full plate breadth, i.e. to the intersection of other plate or longitudinal stiffener - not from the end of the hard corner element nor from the attached plating of ordinary stiffener element, if any.  
In calculating the total forces for checking the hull girder ultimate strength, the area of the stiffened plate element is to be taken between the hard corner element and the ordinary stiffener element or between the hard corner elements, as applicable.

Table 1: Modes of failure of stiffened plate element plating panel and ordinary stiffeners element		
Element	Mode of failure	Curve $\sigma$ - $\varepsilon$ defined in
Lengthened stiffened plate element or ordinary stiffener element	Elasto-plastic collapse	[2.2.3]
	Beam column buckling	[2.2.4]
Shortened ordinary stiffener element	Torsional buckling	[2.2.5]
	Web local buckling of flanged profiles	[2.2.6]
	Web local buckling of flat bars	[2.2.7]
Shortened stiffened plate element	Plate buckling	[2.2.8]

### 2.2.2 Hard corner element

The relevant load-end shortening curve  $\sigma$ - $\varepsilon$  is to be obtained for lengthened and shortened hard corners according to [2.2.3].

### 2.2.3 Elasto-plastic collapse of structural elements

The equation describing the load-end shortening curve  $\sigma$ - $\varepsilon$  for the elasto-plastic collapse of structural elements composing the hull girder transverse section is to be obtained from the following formula, valid for both positive (shortening) and negative (lengthening) strains (see Fig 7):

$$\sigma = \Phi R_{eHA}$$

where:

$R_{eHA}$  = Equivalent minimum yield stress, in  $N/mm^2$ , of the considered element, obtained by the following formula:

$$R_{eHA} = \frac{R_{eHp} A_p + R_{eHs} A_s}{A_p + A_s}$$

$\Phi$  = Edge function, equal to:

$$\begin{aligned} \Phi &= -1 && \text{for } \varepsilon < -1 \\ \Phi &= \varepsilon && \text{for } -1 \leq \varepsilon \leq 1 \\ \Phi &= 1 && \text{for } \varepsilon > 1 \end{aligned}$$

$\varepsilon$  = Relative strain, equal to:

$$\varepsilon = \frac{\varepsilon_E}{\varepsilon_Y}$$

$\varepsilon_E$  = Element strain

$\varepsilon_Y$  = Strain at yield stress in the element, equal to:

$$\varepsilon_Y = \frac{R_{eHA}}{E}$$

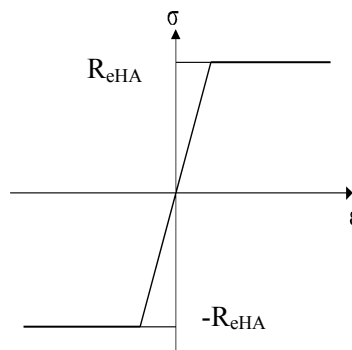

Fig. 7  
Load-end curve  $\sigma$ - $\varepsilon$  for elasto plastic collapse

### 2.2.4 Beam column buckling

The equation describing the load-end shortening curve  $\sigma_{CR1}$ - $\varepsilon$  for the beam column buckling of ordinary stiffeners composing the hull girder transverse section is to be obtained from the following formula (see Fig 8):

$$\sigma_{CR1} = \Phi \sigma_{C1} \frac{A_s + A_{pE}}{A_s + A_p}$$

where:

$\Phi$  = Edge function defined in [2.2.3]

$\sigma_{C1}$  = Critical stress, in  $N/mm^2$ , equal to:

$$\sigma_{C1} = \frac{\sigma_{E1}}{\varepsilon} \quad \text{for} \quad \sigma_{E1} \leq \frac{R_{eHB}}{2} \varepsilon$$

$$\sigma_{C1} = R_{eHB} \left( 1 - \frac{R_{eHB} \varepsilon}{4 \sigma_{E1}} \right) \quad \text{for} \quad \sigma_{E1} > \frac{R_{eHB}}{2} \varepsilon$$

$R_{eHB}$  = Equivalent minimum yield stress, in N/mm<sup>2</sup>, of the considered element, obtained by the following formula:

$$R_{eHB} = \frac{R_{eHp} A_{pE1} l_{pE} + R_{eHs} A_s l_{sE}}{A_{pE1} l_{pE} + A_s l_{sE}}$$

$A_{pE}$  = Effective area, in cm<sup>2</sup>, equal to  $A_{pE1} = 10 b_{E1} t_p$

$l_{pE}$  = Distance, in mm, measured from the neutral axis of the stiffener with attached plate of width  $b_{E1}$  to the bottom of the attached plate

$l_{sE}$  = Distance, in mm, measured from the neutral axis of the stiffener with attached plate of width  $b_{E1}$  to the top of the stiffener

$\varepsilon$  = Relative strain defined in [2.2.3]

$\sigma_{E1}$  = Euler column buckling stress, in N/mm<sup>2</sup>, equal to:

$$\sigma_{E1} = \pi^2 E \frac{I_E}{A_E l^2} 10^{-4}$$

$I_E$  = Net moment of inertia of ordinary stiffeners, in cm<sup>4</sup>, with attached shell plating of width  $b_{E1}$

$b_{E1}$  = Effective width, in m, of the attached shell plating, equal to:

$$b_{E1} = \frac{s}{\beta_E} \quad \text{for} \quad \beta_E > 1.0$$

$$b_{E1} = s \quad \text{for} \quad \beta_E \leq 1.0$$

$$\beta_E = 10^3 \frac{s}{t_p} \sqrt{\frac{\varepsilon R_{eHp}}{E}}$$

$A_{pE}$  = Net sectional area, in cm<sup>2</sup>, of attached shell plating of width  $b_E$ , equal to:

$$A_{pE} = 10 b_E t_p$$

$b_E$  = Effective width, in m, of the attached shell plating, equal to:

$$b_E = \left( \frac{2.25}{\beta_E} - \frac{1.25}{\beta_E^2} \right) s \quad \text{for} \quad \beta_E > 1.25$$

$$b_E = s \quad \text{for} \quad \beta_E \leq 1.25$$

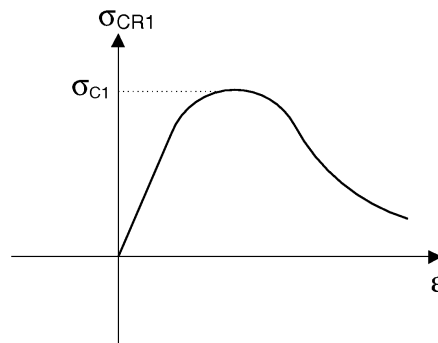

**Fig. 8**  
**Load-end shortening curve  $\sigma_{CR1}$ - $\varepsilon$  for beam column buckling**



### 2.2.5 Torsional buckling

The equation describing the load-end shortening curve  $\sigma_{CR2}-\varepsilon$  for the flexural-torsional buckling of ordinary stiffeners composing the hull girder transverse section is to be obtained according to the following formula (see Fig 9).

$$\sigma_{CR2} = \Phi \frac{A_s \sigma_{C2} + A_p \sigma_{CP}}{A_s + A_p}$$

where:

$\Phi$  = Edge function defined in [2.2.3]

$\sigma_{C2}$  = Critical stress, in N/mm<sup>2</sup>, equal to:

$$\sigma_{C2} = \frac{\sigma_{E2}}{\varepsilon} \quad \text{for} \quad \sigma_{E2} \leq \frac{R_{eHs}}{2} \varepsilon$$

$$\sigma_{C2} = R_{eHs} \left( 1 - \frac{R_{eHs} \varepsilon}{4 \sigma_{E2}} \right) \quad \text{for} \quad \sigma_{E2} > \frac{R_{eHs}}{2} \varepsilon$$

$\sigma_{E2}$  = Euler torsional buckling stress, in N/mm<sup>2</sup>, defined in Ch 6, Sec 3, [4.3]

$\varepsilon$  = Relative strain defined in [2.2.3]

$\sigma_{CP}$  = Buckling stress of the attached plating, in N/mm<sup>2</sup>, equal to:

$$\sigma_{CP} = \left( \frac{2.25}{\beta_E} - \frac{1.25}{\beta_E^2} \right) R_{eHp} \quad \text{for} \quad \beta_E > 1.25$$

$$\sigma_{CP} = R_{eHp} \quad \text{for} \quad \beta_E \leq 1.25$$

$\beta_E$  = Coefficient defined in [2.2.4]

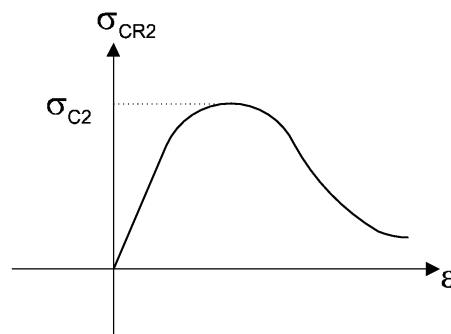

**Fig. 9**  
Load-end shortening curve  $\sigma_{CR2}-\varepsilon$  for flexural-torsional buckling

### 2.2.6 Web local buckling of ordinary stiffeners made of flanged profiles

The equation describing the load-end shortening curve  $\sigma_{CR3}-\varepsilon$  for the web local buckling of flanged ordinary stiffeners composing the hull girder transverse section is to be obtained from the following formula:

$$\sigma_{CR3} = \Phi \frac{10^3 b_E t_p R_{eHp} + (h_w t_w + b_f t_f) R_{eHs}}{10^3 s t_p + h_w t_w + b_f t_f}$$

where

$\Phi$  = Edge function defined in [2.2.3]

$b_E$  = Effective width, in m, of the attached shell plating, defined in [2.2.4]

$h_{we}$  = Effective height, in mm, of the web, equal to:

$$h_{we} = \left( \frac{2.25}{\beta_w} - \frac{1.25}{\beta_w^2} \right) h_w \quad \text{for} \quad \beta_w > 1.25$$

$$h_{we} = h_w \quad \text{for} \quad \beta_w \leq 1.25$$

$$\beta_w = \frac{h_w}{t_w} \sqrt{\frac{\varepsilon R_{eHs}}{E}}$$

$\varepsilon$  = Relative strain defined in [2.2.3]

### 2.2.7 Web local buckling of ordinary stiffeners made of flat bars

The equation describing the load-end shortening curve  $\sigma_{CR4}-\varepsilon$  for the web local buckling of flat bar ordinary stiffeners composing the hull girder transverse section is to be obtained from the following formula (see Fig 10):

$$\sigma_{CR4} = \Phi \frac{A_p \sigma_{CP} + A_s \sigma_{C4}}{A_p + A_s}$$

where:

$\Phi$  = Edge function defined in [2.2.3]

$\sigma_{CP}$  = Buckling stress of the attached plating, in N/mm<sup>2</sup>, defined in [2.2.5]

$\sigma_{C4}$  = Critical stress, in N/mm<sup>2</sup>, equal to:

$$\sigma_{C4} = \frac{\sigma_{E4}}{\varepsilon} \quad \text{for} \quad \sigma_{E4} \leq \frac{R_{eHs}}{2} \varepsilon$$

$$\sigma_{C4} = R_{eHs} \left( 1 - \frac{R_{eHs} \varepsilon}{4 \sigma_{E4}} \right) \quad \text{for} \quad \sigma_{E4} > \frac{R_{eHs}}{2} \varepsilon$$

$\sigma_{E4}$  = Local Euler buckling stress, in N/mm<sup>2</sup>, equal to:

$$\sigma_{E4} = 160000 \left( \frac{t_w}{h_w} \right)^2$$

$\varepsilon$  = Relative strain defined in [2.2.3].

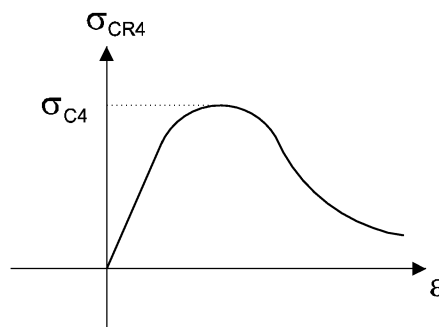

**Fig. 10**  
Load-end shortening curve  $\sigma_{CR4}-\varepsilon$  for web local buckling

### 2.2.8 Plate buckling

The equation describing the load-end shortening curve  $\sigma_{CR5-\varepsilon}$  for the buckling of transversely stiffened panels composing the hull girder transverse section is to be obtained from the following formula:

$$\sigma_{CR5} = \min \left\{ \begin{array}{l} R_{eHp} \Phi \\ \Phi R_{eHp} \left[ \frac{s}{\ell} \left( \frac{2.25}{\beta_E} - \frac{1.25}{\beta_E^2} \right) + 0.1 \left( 1 - \frac{s}{\ell} \right) \left( 1 + \frac{1}{\beta_E^2} \right)^2 \right] \end{array} \right.$$

where:

$\Phi$  = Edge function defined in [2.2.3]

$$\beta_E = 10^3 \frac{s}{t_p} \sqrt{\frac{\varepsilon R_{eHp}}{E}}$$

$s$  = plate breadth, in m, taken as the spacing between the ordinary stiffeners.

$\ell$  = longer side of the plate, in m.



# **Chapter 6**

## **Hull Scantlings**

---

Section 1 Plating

Section 2 Ordinary Stiffeners

Section 3 Buckling and Ultimate Strength of Ordinary Stiffeners and Stiffened Panels

Section 4 Primary Supporting Members

Appendix 1 Buckling and Ultimate Strength



## SECTION 1 PLATING

### Symbols

For symbols not defined in this Section, refer to Ch 1, Sec 4.

- $I_Y$  = Net moment of inertia, in  $m^4$ , of the hull transverse section about its horizontal neutral axis, to be calculated according to Ch 5, Sec 1, [1.5], on gross offered thickness reduced by  $0.5t_C$  for all structural members
- $I_Z$  = Net moment of inertia, in  $m^4$ , of the hull transverse section about its vertical neutral axis, to be calculated according to Ch 5, Sec 1, [1.5], on gross offered thickness reduced by  $0.5t_C$  for all structural members
- $N$  = Z co-ordinate with respect to the reference co-ordinate system defined in Ch 1, Sec 4, [4], in m, of the centre of gravity of the hull net transverse section, defined in Ch 5, Sec 1, [1.2], considering gross offered thickness reduced by  $0.5t_C$  for all structural members
- $t$  = Net thickness, in mm, of a plate panel.
- $p_S, p_W$  = Still water and wave pressure, in  $kN/m^2$ , in intact conditions, defined in [3.1.2]
- $p_F$  = Pressure, in  $kN/m^2$ , in flooded conditions, defined in [3.1.3]
- $p_T$  = Pressure, in  $kN/m^2$ , in testing conditions, defined in [3.1.4]
- $\sigma_X$  = Normal stress, in  $N/mm^2$ , defined in [3.1.5]
- $\ell$  = Length, in m, of the longer side of the elementary plate panel, measured along the chord
- $s$  = Length, in m, of the shorter side of the elementary plate panel, measured along the chord at mid-span of  $\ell$
- $c_a$  = Coefficient of aspect ratio of the plate panel, equal to:
- $$c_a = 1.21 \sqrt{1 + 0.33 \left( \frac{s}{\ell} \right)^2} - 0.69 \frac{s}{\ell},$$
- to be taken not greater than 1.0
- $c_r$  = Coefficient of curvature of the panel, equal to:
- $$c_r = 1 - 0.5 \frac{s}{r},$$
- to be taken not less than 0.4
- $r$  = Radius of curvature, in m.

## 1 General

### 1.1 Application

#### 1.1.1

The requirements of this Section apply for the strength check of plating subjected to lateral pressure and, for plating contributing to the longitudinal strength, to in-plane hull girder normal stress.

In addition, the buckling check of platings and stiffened panels is to be carried out according to Ch 6, Sec 3.

### 1.2 Net thicknesses

#### 1.2.1

As specified in Ch 3, Sec 2, all thicknesses referred to in this Section are net, i.e. they do not include any corrosion addition.

The gross thicknesses are obtained as specified in Ch 3, Sec 2, [3].

#### 1.2.2

The net thickness, in mm, of each plating is given by the greatest of the net thicknesses calculated for each load calculation point, as defined in [1.5.1], representative of the considered plating (see Table 1). The geometry to be considered is that of the elementary plate panel related to the load calculation point.

### **1.3 Pressure combination**

#### **1.3.1 Elements of the outer shell**

The still water and wave lateral pressures are to be calculated considering independently the following cases:

- the still water and wave external sea pressures
- the still water and wave internal pressure considering the compartment adjacent to the outer shell as being loaded. If the compartment adjacent to the outer shell is intended to carry liquids, this still water and wave internal pressures are to be reduced from the corresponding still water and wave external sea pressures.

#### **1.3.2 Elements other than those of the outer shell**

The still water and wave lateral pressures to be considered as acting on an element which separates two adjacent compartments are those obtained considering the two compartments individually loaded.

### **1.4 Elementary plate panel**

#### **1.4.1**

The elementary plate panel (EPP) is the smallest unstiffened part of plating between stiffeners.

### **1.5 Load calculation point**

#### **1.5.1**

Unless otherwise specified, lateral pressure and hull girder stresses are to be calculated:

- for longitudinal framing, at the lower edge of the elementary plate panel (see Table 1) or, in the case of horizontal plating, at the point of minimum y-value among those of the elementary plate panel considered, as the case may be
- for transverse framing, at the lower edge of the elementary plate panel or at the lower edge of the strake (see Table 1) or, in the case of horizontal plating, at the point of minimum y-value among those of the elementary plate panel considered, as the case may be.



Table 1 Load calculation points	
Longitudinally stiffened plating	Transversely stiffened plating
<p>X Load Calculation Point (LCP)</p>	<p>X Load Calculation Point (LCP)</p>

## 2 General requirements

### 2.1 Corrugated bulkhead

#### 2.1.1

Unless otherwise specified, the net plating thickness of a corrugated bulkhead is to be not less than that obtained for a plate panel with  $s$  equal to the greater of  $a$  and  $c$ , where  $a$  and  $c$  are defined in Fig 1.

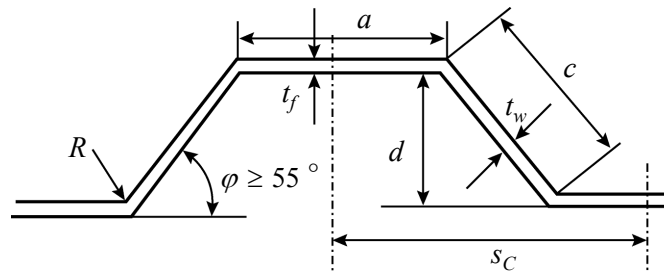

Fig. 1  
Corrugated bulkhead

### 2.2 Minimum net thicknesses

#### 2.2.1

The net thickness of plating is to be not less than the values given in Table 2.

In addition, in the cargo area, the net thickness of side shell plating, from the normal ballast draught to  $0.25T_s$  (minimum 2.2 m) above  $T_s$ , is to be not less than the value obtained, in mm, from the following formula:

$$t = 28(s + 0.7) \frac{(BT_s)^{0.25}}{\sqrt{R_{eH}}}$$

Table 2 Minimum net thickness of plating	
Plating	Minimum net thickness, in mm
Keel	$7.5 + 0.03L$
Bottom, inner bottom	$5.5 + 0.03L$
Weather strength deck and trunk deck, if any	$4.5 + 0.02L$
Side shell, bilge	$0.85L^{1/2}$
Inner side, hopper sloping plate and topside sloping plate	$0.7L^{1/2}$
Transverse and longitudinal watertight bulkheads	$0.6L^{1/2}$
Wash bulkheads	6.5
Accommodation deck	5.0

## **2.3 Bilge plating**

### **2.3.1**

The net thickness of the longitudinally framed bilge plating, in mm, is to be not less than the value obtained from [3.2].

### **2.3.2**

The net thickness of the transversely framed bilge plating, in mm, is to be not less than the value obtained from the following formula:

$$t = 0.76[(p_S + p_W)s_b]^{0.4} R^{0.6} k^{0.5}$$

where :

$R$  = Bilge radius, in m

$s_b$  = Spacing of floors or transverse bilge brackets, in m.

### **2.3.3**

The net thickness of the bilge plating is to be not less than the actual net thicknesses of the adjacent 2 m width bottom or side plating, whichever is the greater.

## **2.4 Keel plating**

### **2.4.1**

The net thickness of the keel plating is to be not less than the actual net thicknesses of the adjacent 2 m width bottom plating.

## **2.5 Sheerstrake**

### **2.5.1 Welded sheerstrake**

The net thickness of a welded sheerstrake is to be not less than the actual net thicknesses of the adjacent 2 m width side plating, taking into account higher strength steel corrections if needed.

### **2.5.2 Rounded sheerstrake**

The net thickness of a rounded sheerstrake is to be not less than the actual net thickness of the adjacent deck plating.

### **2.5.3 Net thickness of the sheerstrake in way of breaks of effective superstructures**

The net thickness of the sheerstrake is to be increased in way of breaks of effective superstructures occurring within  $0.5L$  amidships, over a length of about one sixth of the ship's breadth on each side of the superstructure end.

This increase in net thickness is not to be less than 40% of the net thickness of sheerstrake, but need not exceed 4.5 mm.

Where the breaks of superstructures occur outside  $0.5L$  amidships, the increase in net thickness may be reduced to 30%, but need not exceed 2.5 mm.

### **2.5.4 Net thickness of the sheerstrake in way of breaks of non-effective superstructures**

The net thickness of the sheerstrake is to be increased in way of breaks of non-effective superstructures occurring within  $0.6L$  amidships, over a length of about one sixth of the ship's breadth on each side of the superstructure end.

This increase in net thickness is to be equal to 15%, but need not exceed 4.5 mm.

## **2.6 Stringer plate**

### **2.6.1 General**

The net thickness of the stringer plate is to be not less than the actual net thickness of the adjacent deck plating.

### **2.6.2 Net thickness of the stringer plate in way of breaks of long superstructures**

The net thickness of the stringer plate is to be increased in way of breaks of long superstructures occurring within  $0.5L$  amidships, over a length of about one sixth of the ship's breadth on each side of the superstructure

end.

This increase in net thickness is not to be less than 40% of the net thickness of stringer plate, but need not exceed 4.5 mm.

Where the breaks of superstructures occur outside 0.5L amidships, the increase in net thickness may be reduced to 30%, but need not exceed 2.5 mm.

### 2.6.3 Net thickness of the stringer plate in way of breaks of short superstructures

The net thickness of the stringer plate is to be increased in way of breaks of short superstructures occurring within 0.6L amidships, over a length of about one sixth of the ship breadth on each side of the superstructure end.

This increase in net thickness is to be equal to 15%, but need not exceed 4.5 mm.

## 2.7 Inner bottom loaded by steel coils on a wooden support

### 2.7.1 General

The net thickness of inner bottom, bilge hopper sloping plate and inner hull for ships intended to carry steel coils is to comply with [2.7.3] to [2.7.5].

The provision is determined by assuming Fig 2 as the standard means of securing steel coils.

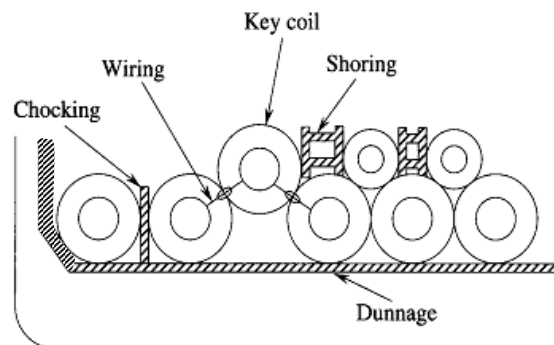

Fig. 2  
Inner bottom loaded by steel coils

### 2.7.2 Accelerations

In order to calculate the accelerations, the following coordinates are to be used for the centre of gravity.

$x_{G-sc} = 0.75 \ell_H$  forward of aft bulkhead, where the hold of which the mid position is located forward from 0.45L from A.E.

$x_{G-sc} = 0.75 \ell_H$  afterward of fore bulkhead, where the hold of which the mid position is located afterward from 0.45L from A.E.

$$y_{G-sc} = \varepsilon \frac{B_h}{4}$$

$$z_{G-sc} = h_{DB} + \left\{ 1 + (n_1 - 1) \frac{\sqrt{3}}{2} \right\} \frac{d_{sc}}{2}$$

where:

$\varepsilon = 1.0$  when a port side structural member is considered, or  $-1.0$  when a starboard side structural member is considered.

$B_h =$  breadth in m, at the mid of the hold, of the cargo hold at the level of connection of bilge hopper plate with side shell or inner hull

$d_{sc} =$  diameter of steel coils, in m

$h_{DB} =$  height of inner bottom, in m

$\ell_H =$  Cargo hold length, in m

Vertical acceleration  $a_z$ , in  $m/s^2$ , are to be calculated by the formulae defined in Ch 4, Sec 2, [3.2] and

tangential acceleration  $a_R$  due to roll, in  $m/s^2$  is to be calculated by the following formula.

$$a_R = \theta \frac{\pi}{180} \left( \frac{2\pi}{T_R} \right)^2 \sqrt{y_{G\_SC}^2 + R^2}$$

where:

$\theta$ ,  $T_R$  and  $R$ : as defined in Ch 4 Sec 2, [3.2].

### 2.7.3 Inner bottom plating

The net thickness of plating of longitudinally framed inner bottom is to be not less than the value obtained, in mm, from the following formula:

$$t = K_1 \sqrt{\frac{\{g(\cos(C_{ZP}\Phi)\cos(C_{ZR}\theta)) + a_z\}F}{\lambda_p R_y}}$$

where:

$K_1$  = Coefficient taken equal to:

$$K_1 = \sqrt{\frac{1.7s\ell K_2 - 0.73s^2 K_2^2 - (\ell - \ell')^2}{2\ell'(2s + 2\ell K_2)}}$$

$a_z$  = Vertical acceleration, in  $m/s^2$ , defined in [2.7.2]

$\Phi$  = Single pitch amplitude, in deg, defined in Ch 4, Sec 2, [2.2]

$\theta$  = Single roll amplitude, in deg, defined in Ch 4, Sec 2, [2.1]

$C_{ZP}, C_{ZR}$  = Load combination factor defined in Ch 4, Sec 4, [2.2]

$F$  = Force, in kg, taken equal to:

$$F = K_S \frac{W n_1 n_2}{n_3} \quad \text{for } n_2 \leq 10 \text{ and } n_3 \leq 5$$

$$F = K_S n_1 W \frac{l}{l_S} \quad \text{for } n_2 > 10 \text{ or } n_3 > 5$$

$\lambda_p$  = Coefficient defined in Table 6

$K_S$  = Coefficient taken equal to:

$K_S = 1.4$  when steel coils are lined up in one tier with a key coil

$K_S = 1.0$  in other cases

$W$  = Mass of one steel coil, in kg

$n_1$  = Number of tiers of steel coils

$n_2$  = Number of load points per elementary plate panel (See Figs 3 and 4).

When  $n_3 \leq 5$ ,  $n_2$  can be obtained from Table 3 according to the values of  $n_3$  and  $\ell / \ell_S$ .

$n_3$  = Number of dunnages supporting one steel coil

$\ell_S$  = Length of a steel coil, in m

$K_2$  = Coefficient taken equal to:

$$K_2 = -\frac{s}{\ell} + \sqrt{\left(\frac{s}{\ell}\right)^2 + 1.37\left(\frac{\ell}{s}\right)^2 \left(1 - \frac{\ell'}{\ell}\right)^2 + 2.33}$$

$\ell'$  = Distance, in m, between outermost load points per elementary plate panel in ship length (See Figs 3 and 4). When  $n_2 \leq 10$  and  $n_3 \leq 5$ ,  $\ell'$  can be obtained from Table 4 according to the values of  $\ell$ ,  $\ell_S$ ,  $n_2$  and  $n_3$ . When  $n_2 > 10$  or  $n_3 > 5$ ,  $\ell'$  is to be taken equal to  $\ell$ .

### 2.7.4 Bilge hopper sloping plate and inner hull plate

The net thickness of plating of longitudinally framed bilge hopper sloping plate and inner hull is to be not less than the value obtained, in mm, from the following formula:

$$t = K_1 \sqrt{\frac{a_{hopper} F'}{\lambda_p R_y}}$$

where:

$K_1$  = Coefficient defined in [2.7.3]  
 $\theta_h$  = Angle, in deg, between inner bottom plate and bilge hopper sloping plate or inner hull plate

$$a_{hopper} = -C_{YR}a_R \sin\left(\tan^{-1}\left|\frac{y_{G\_sc}}{R}\right| - \theta_h\right) + g \cos(\theta_h - C_{YG}\theta) \cos(C_{XG}\Phi) + C_{YS}a_{sway} \sin \theta_h$$

$a_R$  = tangential acceleration defined in [2.7.2].  
 $a_{sway}$  = Transverse acceleration due to sway, in  $m/s^2$ , defined in Ch 4, Sec 2, [2.4]  
 $C_{XG}, C_{YS}, C_{YR}, C_{YG}$  = Load combination factors defined in Ch 4, Sec 4, [2.2]  
 $y_{G\_sc}$  = Centre of gravity in transverse direction, in m, defined in [2.7.2]  
 $R$  = Coefficient defined in Ch 4 Sec 2, [3.2.1]  
 $F'$  = Force, in kg, taken equal to:

$$F' = \frac{Wn_2C_k}{n_3} \quad \text{for } n_2 \leq 10 \text{ and } n_3 \leq 5$$

$$F' = C_k W \frac{l}{l_s} \quad \text{for } n_2 > 10 \text{ or } n_3 > 5$$

$\lambda_P$  = Coefficient defined in Table 6  
 $W, n_2, n_3, \Phi$  and  $\theta$  = As defined in [2.7.3]  
 $C_k$  = Coefficient taken equal to:

$C_k = 3.2$  when steel coils are lined up two or more tier, or when steel coils are lined up one tier and key coil is located second or third from bilge hopper sloping plate or inner hull plate  
 $C_k = 2.0$  for other cases

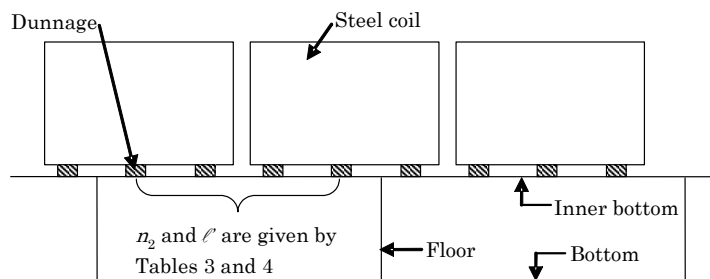

**Fig. 3**  
Loading condition of steel coils (Example of  $n_2 = 4, n_3 = 3$ )

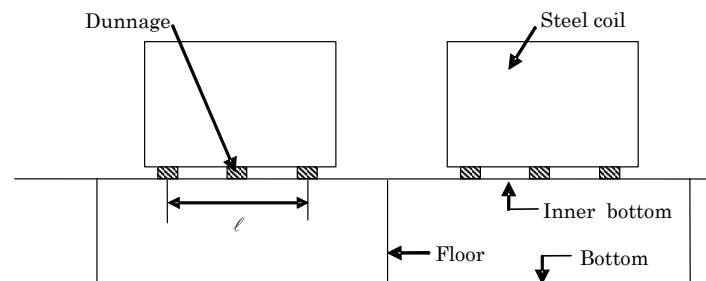

**Fig. 4**  
Loading condition of steel coils (Example of  $n_2 = 3, n_3 = 3$ )

$n_2$	$n_3 = 2$	$n_3 = 3$	$n_3 = 4$	$n_3 = 5$
1	$0 < \frac{l}{l_S} \leq 0.5$	$0 < \frac{l}{l_S} \leq 0.33$	$0 < \frac{l}{l_S} \leq 0.25$	$0 < \frac{l}{l_S} \leq 0.2$
2	$0.5 < \frac{l}{l_S} \leq 1.2$	$0.33 < \frac{l}{l_S} \leq 0.67$	$0.25 < \frac{l}{l_S} \leq 0.5$	$0.2 < \frac{l}{l_S} \leq 0.4$
3	$1.2 < \frac{l}{l_S} \leq 1.7$	$0.67 < \frac{l}{l_S} \leq 1.2$	$0.5 < \frac{l}{l_S} \leq 0.75$	$0.4 < \frac{l}{l_S} \leq 0.6$
4	$1.7 < \frac{l}{l_S} \leq 2.4$	$1.2 < \frac{l}{l_S} \leq 1.53$	$0.75 < \frac{l}{l_S} \leq 1.2$	$0.6 < \frac{l}{l_S} \leq 0.8$
5	$2.4 < \frac{l}{l_S} \leq 2.9$	$1.53 < \frac{l}{l_S} \leq 1.87$	$1.2 < \frac{l}{l_S} \leq 1.45$	$0.8 < \frac{l}{l_S} \leq 1.2$
6	$2.9 < \frac{l}{l_S} \leq 3.6$	$1.87 < \frac{l}{l_S} \leq 2.4$	$1.45 < \frac{l}{l_S} \leq 1.7$	$1.2 < \frac{l}{l_S} \leq 1.4$
7	$3.6 < \frac{l}{l_S} \leq 4.1$	$2.4 < \frac{l}{l_S} \leq 2.73$	$1.7 < \frac{l}{l_S} \leq 1.95$	$1.4 < \frac{l}{l_S} \leq 1.6$
8	$4.1 < \frac{l}{l_S} \leq 4.8$	$2.73 < \frac{l}{l_S} \leq 3.07$	$1.95 < \frac{l}{l_S} \leq 2.4$	$1.6 < \frac{l}{l_S} \leq 1.8$
9	$4.8 < \frac{l}{l_S} \leq 5.3$	$3.07 < \frac{l}{l_S} \leq 3.6$	$2.4 < \frac{l}{l_S} \leq 2.65$	$1.8 < \frac{l}{l_S} \leq 2.0$
10	$5.3 < \frac{l}{l_S} \leq 6.0$	$3.6 < \frac{l}{l_S} \leq 3.93$	$2.65 < \frac{l}{l_S} \leq 2.9$	$2.0 < \frac{l}{l_S} \leq 2.4$

$n_2$	$n_3$			
	2	3	4	5
1	Actual breadth of dunnage			
2	$0.5l_S$	$0.33l_S$	$0.25l_S$	$0.2l_S$
3	$1.2l_S$	$0.67l_S$	$0.50l_S$	$0.4l_S$
4	$1.7l_S$	$1.20l_S$	$0.75l_S$	$0.6l_S$
5	$2.4l_S$	$1.53l_S$	$1.20l_S$	$0.8l_S$
6	$2.9l_S$	$1.87l_S$	$1.45l_S$	$1.2l_S$
7	$3.6l_S$	$2.40l_S$	$1.70l_S$	$1.4l_S$
8	$4.1l_S$	$2.73l_S$	$1.95l_S$	$1.6l_S$
9	$4.8l_S$	$3.07l_S$	$2.40l_S$	$1.8l_S$
10	$5.3l_S$	$3.60l_S$	$2.65l_S$	$2.0l_S$

### 2.7.5

Void

## 3 Strength check of plating subjected to lateral pressure

### 3.1 Load model

#### 3.1.1 General

The still water and wave lateral pressures induced by the sea and the various types of cargoes and ballast in intact conditions are to be considered, depending on the location of the plating under consideration and the type of the

compartments adjacent to it.

The plating which constitutes the boundary of compartments not intended to carry liquid (excluding bottom and side shell plating) is to be subjected to lateral pressure in flooded conditions.

The wave lateral pressures and hull girder loads are to be calculated, for the probability level of  $10^{-8}$ , in the mutually exclusive load cases H1, H2, F1, F2, R1, R2, P1 and P2, as defined in Ch 4, Sec 4.

### 3.1.2 Lateral pressure in intact conditions

The lateral pressure in intact conditions is constituted by still water pressure and wave pressure.

Still water pressure  $p_S$  includes:

- the hydrostatic pressure, defined in Ch 4, Sec 5, [1]
- the still water internal pressure, defined in Ch 4, Sec 6 for the various types of cargoes and for ballast.

Wave pressure  $p_W$  includes for each load case H1, H2, F1, F2, R1, R2, P1 and P2:

- the hydrodynamic pressure, defined in Ch 4, Sec 5, [1]
- the inertial pressure, defined in Ch 4, Sec 6 for the various types of cargoes and for ballast.

### 3.1.3 Lateral pressure in flooded conditions

The lateral pressure in flooded conditions  $p_F$  is defined in Ch 4, Sec 6, [3.2.1].

### 3.1.4 Lateral pressure in testing conditions

The lateral pressure  $p_T$  in testing conditions is taken equal to:

- $p_T = p_{ST} - p_S$  for bottom shell plating and side shell plating
- $p_T = p_{ST}$  otherwise,

where:

$p_{ST}$  = Testing pressure defined in Ch 4, Sec 6, [4]

$p_S$  = Pressure taken equal to:

- if the testing is carried out afloat: hydrostatic pressure defined in Ch 4, Sec 5, [1] for the draught  $T_1$ , defined by the Designer, at which the testing is carried out. If  $T_1$  is not defined, the testing is considered as being not carried out afloat
- if the testing is not carried out afloat:  $p_S = 0$ .

### 3.1.5 Normal stresses

The normal stress to be considered for the strength check of plating contributing to the hull girder longitudinal strength is the maximum value of  $\sigma_X$  between sagging and hogging conditions, when applicable, obtained, in N/mm<sup>2</sup>, from the following formula:

$$\sigma_x = \left[ C_{SW} \left| \frac{M_{SW}}{I_y} \right| (z - N) + C_{WV} \left| \frac{M_{WV}}{I_y} \right| (z - N) - C_{WH} \left| \frac{M_{WH}}{I_z} \right| y \right] 10^{-3}$$

where:

- $M_{SW}$  = Permissible still water bending moments, in kN.m, in hogging or sagging as the case may be
- $M_{WV}$  = Vertical wave bending moment, in kN.m, in hogging or sagging as the case may be, as defined in Ch 4, Sec 3
- $M_{WH}$  = Horizontal wave bending moment, in kN.m, as defined in Ch 4, Sec 3
- $C_{SW}$  = Combination factor for each load case H1, H2, F1, F2, R1, R2, P1 and P2 and defined in Table 5
- $C_{WV}, C_{WH}$  = Combination factors defined in Ch 4, Sec 4, [2.2] for each load case H1, H2, F1, F2, R1, R2, P1 and P2 and given in Table 5.

Table 5 Combination factors $C_{SW}$ , $C_{WV}$ and $C_{WH}$						
LC	Hogging			Sagging		
	$C_{SW}$	$C_{WV}$	$C_{WH}$	$C_{SW}$	$C_{WV}$	$C_{WH}$
H1	Not Applicable			-1	-1	0
H2	1	1	0	Not Applicable		

<b>F1</b>	Not Applicable			-1	-1	0
<b>F2</b>	1	1	0	Not Applicable		
<b>R1</b>	1	0	$1.2 - \frac{T_{LC}}{T_S}$	-1	0	$1.2 - \frac{T_{LC}}{T_S}$
<b>R2</b>	1	0	$\frac{T_{LC}}{T_S} - 1.2$	-1	0	$\frac{T_{LC}}{T_S} - 1.2$
<b>P1</b>	1	$0.4 - \frac{T_{LC}}{T_S}$	0	-1	$0.4 - \frac{T_{LC}}{T_S}$	0
<b>P2</b>	1	$\frac{T_{LC}}{T_S} - 0.4$	0	-1	$\frac{T_{LC}}{T_S} - 0.4$	0

### 3.2 Plating thickness

#### 3.2.1 Intact conditions

The net thickness of laterally loaded plate panels is to be not less than the value obtained, in mm, from the following formula:

$$t = 15.8c_a c_r s \sqrt{\frac{p_S + p_W}{\lambda_p R_Y}}$$

where:

$\lambda_p$  = Coefficient defined in Table 6.

Plating		Coefficient $\lambda_p$
Contributing to the hull girder longitudinal strength	Longitudinally framed plating	$0.95 - 0.45 \left  \frac{\sigma_X}{R_Y} \right $ , without being taken greater than 0.9
	Transversely framed plating	$0.95 - 0.90 \left  \frac{\sigma_X}{R_Y} \right $ , without being taken greater than 0.9
Not contributing to the hull girder longitudinal strength		0.9

#### 3.2.2 Net thickness under flooded conditions excluding corrugations of transverse vertically corrugated bulkhead separating cargo holds

The plating which constitutes the boundary of compartments not intended to carry liquids (excluding bottom plating and side shell plating), and excluding corrugations of transverse vertically corrugated bulkhead separating cargo holds is to be checked in flooded conditions. To this end, its net thickness is to be not less than the value obtained, in mm, from the following formula:

$$t = 15.8c_a c_r s \sqrt{\frac{p_F}{\alpha \lambda_p R_Y}}$$

where:

$\lambda_p$  = Coefficient defined in Table 6, determined by considering  $\sigma_X$  in flooded condition

$\alpha$  = Coefficient taken equal to:

$\alpha = 0.95$  for the plating of collision bulkhead

$\alpha = 1.15$  for the plating of other watertight boundaries of compartments.

#### 3.2.3 Net thickness of corrugation of transverse vertically corrugated watertight bulkheads separating cargo holds for flooded conditions

The net plate thickness  $t$ , in mm, of transverse vertically corrugated watertight bulkheads separating cargo



holds is to be not less than that obtained from the following formula:

$$t = 14.9s \sqrt{\frac{1.05p}{R_{eH}}}$$

$p$  = Resultant pressure, in kN/m<sup>2</sup>, as defined in Ch 4, Sec 6, [3.3.7]

$s$  = plate width, in m, to be taken equal to the width of the corrugation flange or web, whichever is greater.

For built-up corrugation bulkheads, when the thicknesses of the flange and web are different:

— the net thickness of the narrower plating is to be not less than that obtained, in mm, from the following formula:

$$t_N = 14.9s \sqrt{\frac{1.05p}{R_{eH}}}$$

$s$  : plate width, in m, of the narrower plating

— the net thickness of the wider plating is not to be less than the greater of those obtained, in mm, from the following formulae:

$$t_W = 14.9s \sqrt{\frac{1.05p}{R_{eH}}}$$

$$t_W = \sqrt{\frac{462s^2p}{R_{eH}} - t_{NP}^2}$$

where:

$t_{NP}$  = Actual net thickness of the narrower plating, in mm, to be not taken greater than:

$$t_{NP} = 14.9s \sqrt{\frac{1.05p}{R_{eH}}}$$

$s$  = plate width, in m, to be taken equal to the width of the corrugation flange or web, whichever is greater.

The net thickness of the lower part of corrugations is to be maintained for a distance from the inner bottom (if no lower stool is fitted) or the top of the lower stool not less than  $0.15l_C$ , where  $l_C$  is the span of the corrugations, in m, to be obtained according to Ch 3, Sec 6, [10.4.4]. The net thickness is also to comply with the requirements in [3.2.1], Sec 2, [3.6.1 & 3.6.2], and Sec 3, [6].

The net thickness of the middle part of corrugations is to be maintained for a distance from the deck (if no upper stool is fitted) or the bottom of the upper stool not greater than  $0.3l_C$ . The net thickness is also to comply with the requirements in [3.2.1] and Sec 2, [3.6.1 & 3.6.2].

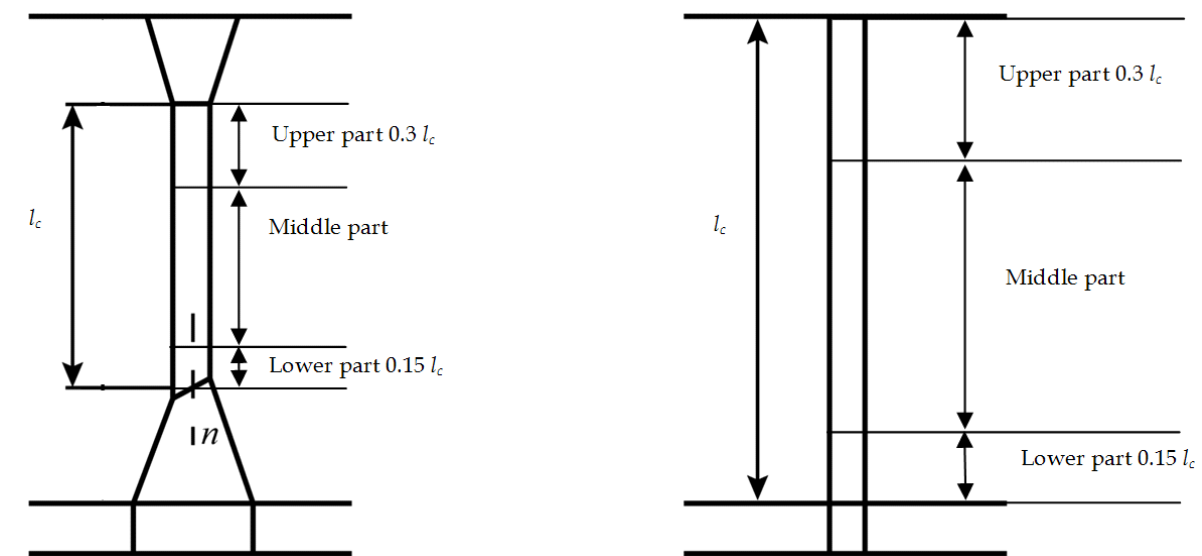

Fig. 5  
Parts of Corrugation

### 3.2.4 Net thickness of lower stool and upper stool

The net thickness and material of the stool top plate of lower stool are to be not less than those for the corrugated bulkhead plating above required by [3.2.3].

The net thickness and material of the upper portion of vertical or sloping stool side plating of lower stool within the depth equal to the corrugation flange width from the stool top are to be not less than the flange plate at the lower end of the corrugation required by [3.2.3], as applicable, whichever is the greater.

The net thickness and material of the stool bottom plate of upper stool are to be the same as those of the bulkhead plating below required by [3.2.3], as applicable, whichever is the greater.

The net thickness of the lower portion of stool side plating is to be not less than 80% of the upper part of the bulkhead plating required by [3.2.3], as applicable, whichever is the greater, where the same material is used.

The net thicknesses of lower stool and upper stool are to be not less than those required by [3.2.1], [3.2.2] and [3.2.6].

### 3.2.5 Net thickness of supporting floors of corrugated bulkhead

The net thickness and material of the supporting floors and pipe tunnel beams of corrugated bulkhead, when no stool is fitted, are to be not less than those of the corrugation flanges required by [3.2.3]

When a lower stool is fitted, the net thickness of supporting floors are to be not less than that of the stool side plating required by the first sentence of [3.2.2].

### 3.2.6 Testing conditions

The plating of compartments or structures as defined in Ch 4, Sec 6, [4] is to be checked in testing conditions. To this end, its net thickness is to be not less than the value obtained, in mm, from the following formula:

$$t = 15.8c_a c_r s \sqrt{\frac{p_T}{1.05R_Y}}$$

## SECTION 2 ORDINARY STIFFENERS

### Symbols

For symbols not defined in this Section, refer to Ch 1, Sec 4.

- $L_2$  = Rule length  $L$ , but to be taken not greater than 300 m
- $I_Y$  = Net moment of inertia, in  $m^4$ , of the hull transverse section about its horizontal neutral axis, to be calculated according to Ch 5, Sec 1, [1.5], on gross offered thickness reduced by  $0.5t_C$  for all structural members
- $I_Z$  = Net moment of inertia, in  $m^4$ , of the hull transverse section about its vertical neutral axis, to be calculated according to Ch 5, Sec 1, [1.5], on gross offered thickness reduced by  $0.5t_C$  for all structural members
- $N$  = Z co-ordinate with respect to the reference co-ordinate system defined in Ch 1, Sec 4, [4], in m, of the centre of gravity of the hull net transverse section defined in Ch 5, Sec 1, [1.2], considering gross offered thickness reduced by  $0.5t_C$  for all structural members
- $p_S, p_W$  = Still water and wave pressure, in  $kN/m^2$ , in intact conditions, defined in [3.1.2]
- $p_F$  = Pressure, in  $kN/m^2$ , in flooded conditions, defined in [3.1.3]
- $p_T$  = Pressure, in  $kN/m^2$ , in testing conditions, defined in [3.1.4]
- $\sigma_X$  = Normal stress, in  $N/mm^2$ , defined in [3.1.5]
- $s$  = Spacing, in m, of ordinary stiffeners, measured at mid-span along the chord
- $\ell$  = Span, in m, of ordinary stiffeners, measured along the chord between the supporting members, see Ch 3, Sec 6, [4.2]
- $h_w$  = Web height, in mm
- $t_w$  = Net web thickness, in mm
- $b_f$  = Face plate width, in mm
- $t_f$  = Net face plate thickness, in mm
- $b_p$  = Width, in m, of the plating attached to the stiffener, for the yielding check, defined in Ch 3, Sec 6, [4.3]
- $w$  = Net section modulus, in  $cm^3$ , of the stiffener, with an attached plating of width  $b_p$ , to be calculated as specified in Ch 3, Sec 6, [4.4]
- $A_{sh}$  = Net shear sectional area, in  $cm^2$ , of the stiffener, to be calculated as specified in Ch 3, Sec 6, [4.4]
- $m$  = Coefficient taken equal to:  
 $m = 10$  for vertical stiffeners  
 $m = 12$  for other stiffeners
- $\tau_a$  = Allowable shear stress, in  $N/mm^2$ , taken equal to:

$$\tau_a = \frac{R_y}{\sqrt{3}}$$

## 1 General

### 1.1 Application

#### 1.1.1

The requirements of this Section apply for the yielding check of ordinary stiffeners subjected to lateral pressure and, for ordinary stiffeners contributing to the hull girder longitudinal strength, to hull girder normal stresses. The yielding check is also to be carried out for ordinary stiffeners subjected to specific loads, such as concentrated loads.

In addition, the buckling check of ordinary stiffeners is to be carried out according to Ch 6, Sec 3.

### 1.2 Net scantlings

#### 1.2.1

As specified in Ch 3, Sec 2, all scantlings referred to in this Section are net, i.e. they do not include any corrosion addition.

The gross scantlings are obtained as specified in Ch 3, Sec 2, [3].

## 1.3 Pressure combination

### 1.3.1 Elements of the outer shell

The still water and wave lateral pressures are to be calculated considering independently the following cases:

- the still water and wave external sea pressures
- the still water and wave internal pressure considering the compartment adjacent to the outer shell as being loaded. If the compartment adjacent to the outer shell is intended to carry liquids, this still water and wave internal pressures are to be reduced from the corresponding still water and wave external sea pressures.

### 1.3.2 Elements other than those of the outer shell

The still water and wave lateral pressures to be considered as acting on an element which separates two adjacent compartments are those obtained considering the two compartments individually loaded.

## 1.4 Load calculation point

### 1.4.1 Horizontal stiffeners

Unless otherwise specified, lateral pressure and hull girder stress, if any, are to be calculated at mid-span of the ordinary stiffener considered.

### 1.4.2 Vertical stiffeners

The lateral pressure  $p$  is to be calculated as the maximum between the value obtained at mid-span and the value obtained from the following formula:

—  $p = \frac{p_U + p_L}{2}$  , when the upper end of the vertical stiffener is below the lowest zero pressure level

—  $p = \frac{\ell_1}{\ell} \frac{p_L}{2}$  , when the upper end of the vertical stiffener is at or above the lowest zero pressure level (see Fig 1)

where:

$\ell_1$  = Distance, in m, between the lower end of vertical stiffener and the lowest zero pressure level

$p_U, p_L$  = Lateral pressures at the upper and lower end of the vertical stiffener span  $\ell$ , respectively.

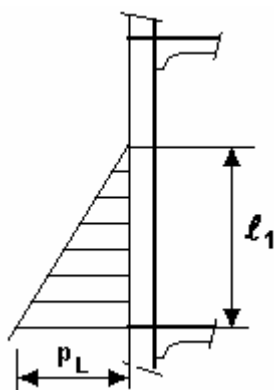

Fig. 1  
Definition of pressure for vertical stiffeners

## 2 General requirements

### 2.1 (Void)

#### 2.1.1

(Void)

Fig. 2  
(Void)

## 2.2 Net thicknesses of webs of ordinary stiffeners

### 2.2.1 Minimum net thicknesses of webs of ordinary stiffeners other than side frames of single side bulk carriers

The net thickness of the web of ordinary stiffeners, in mm, is to be not less than the greater of:

- $t = 3.0 + 0.015L_2$
- 40% of the net required thickness of the attached plating, to be determined according to Ch 6, Sec 1.

and is to be less than 2 times the net offered thickness of the attached plating.

### 2.2.2 Minimum net thicknesses of side frames of single side bulk carriers

The net thickness of side frame webs within the cargo area, in mm, is to be not less than the value obtained from the following formula:

$$t_{MIN} = 0.75\alpha(7 + 0.03L)$$

where:

$\alpha$  = Coefficient taken equal to:

- $\alpha = 1.15$  for the frame webs in way of the foremost hold
- $\alpha = 1.00$  for the frame webs in way of other holds.

### 2.2.3 Maximum net thickness of web of ordinary stiffener

The net thickness of the web of ordinary stiffeners, in mm, is to be less than 2 times the net offered thickness of the attached plating.

## 2.3 Net dimensions of ordinary stiffeners

### 2.3.1 Flat bar

The net dimensions of a flat bar ordinary stiffener (see Fig 3) are to comply with the following requirement:

$$\frac{h_w}{t_w} \leq 20\sqrt{k}$$

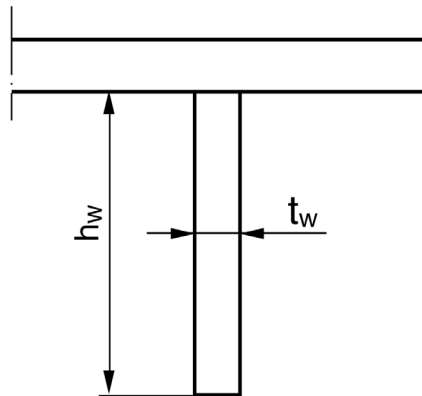

**Fig. 3**  
Net dimensions of a flat bar

### 2.3.2 T-section

The net dimensions of a T-section ordinary stiffener (see Fig 4) are to comply with the following requirements:

$$\frac{h_w}{t_w} \leq 65\sqrt{k}$$

$$\frac{b_f}{t_f} \leq 33\sqrt{k}$$

$$b_f t_f \geq \frac{h_w t_w}{6}$$

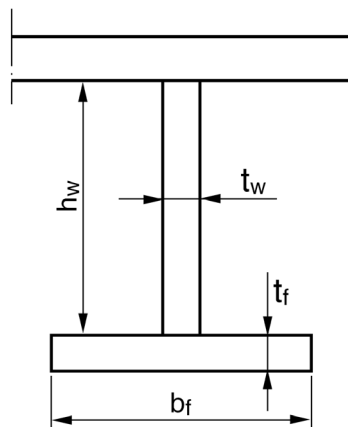

**Fig. 4**  
 Net dimensions of a T-section

### 2.3.3 Angle

The net dimensions of an angle ordinary stiffener (see Fig 5) are to comply with the following requirements:

$$\frac{h_w}{t_w} \leq 55\sqrt{k}$$

$$\frac{b_f}{t_f} \leq 16.5\sqrt{k}$$

$$b_f t_f \geq \frac{h_w t_w}{6}$$

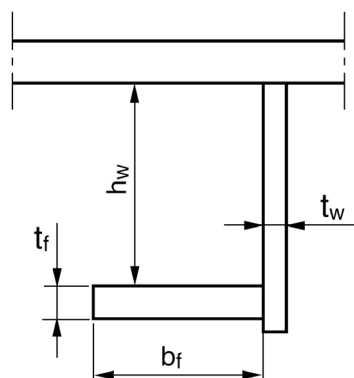

**Fig. 5**  
 Net dimensions of an angle

## 2.4 Struts connecting ordinary stiffeners

### 2.4.1

The net sectional area  $A_{SR}$ , in  $\text{cm}^2$ , and the net moment of inertia  $I_{SR}$  about the main axes, in  $\text{cm}^4$ , of struts connecting ordinary stiffeners are to be not less than the values obtained from the following formulae:

$$A_{SR} = \frac{p_{SR} s \ell}{20}$$

$$I_{SR} = \frac{0.75 s \ell (p_{SR1} + p_{SR2}) A_{ASR} \ell_{SR}^2}{47.2 A_{ASR} - s \ell (p_{SR1} + p_{SR2})}$$

where:

$p_{SR}$  = Pressure to be taken equal to the greater of the values obtained, in  $\text{kN/m}^2$ , from the following formulae:

$$p_{SR} = 0.5(p_{SR1} + p_{SR2})$$

$$p_{SR} = p_{SR3}$$

$p_{SR1}$  = External pressure in way of the strut, in  $\text{kN/m}^2$ , acting on one side, outside the compartment in which the strut is located

$p_{SR2}$  = External pressure in way of the strut, in  $\text{kN/m}^2$ , acting on the opposite side, outside the compartment in which the strut is located

$p_{SR3}$  = Internal pressure at mid-span of the strut, in  $\text{kN/m}^2$ , in the compartment in which the strut is located

$\ell$  = Span, in m, of ordinary stiffeners connected by the strut (see Ch 3, Sec 6, [4.2.3])

$\ell_{SR}$  = Length, in m, of the strut

$A_{ASR}$  = Actual net sectional area, in  $\text{cm}^2$ , of the strut.

## 2.5 Ordinary stiffeners of inner bottom loaded by steel coils on a wooden support

### 2.5.1 General

The requirements of this sub-article apply to the ordinary stiffeners located on inner bottom plate, bilge hopper sloping plate and inner hull plate when loaded by steel coils on a wooden support (dunnage), as indicated in Fig 2 of Ch 6, Sec 1.

### 2.5.2 Ordinary stiffeners located on inner bottom plating

The net section modulus  $w$ , in  $\text{cm}^3$ , and the net shear sectional area  $A_{sh}$ , in  $\text{cm}^2$ , of single span ordinary stiffeners located on inner bottom plating are to be not less than the values obtained from the following formulae:

$$w = K_3 \frac{[g \cdot \cos(C_{ZP}\Phi) \cdot \cos(C_{ZR}\theta) + a_Z] \cdot F}{8 \cdot \lambda_S R_Y}$$

$$A_{sh} = \frac{5[g \cdot \cos(C_{ZP}\Phi) \cdot \cos(C_{ZR}\theta) + a_Z] \cdot F}{\tau_a \sin \phi} 10^{-3}$$

where:

$K_3$  = Coefficient defined in Table 1. When  $n_2$  is greater than 10,  $K_3$  is to be taken equal to  $2\ell/3$

$a_Z$  = Vertical acceleration, in  $\text{m/s}^2$ , defined in Ch 6, Sec 1, [2.7.2]

$\Phi$  = Single pitch amplitude, in deg, defined in Ch 4, Sec 2, [2.2]

$\theta$  = Single roll amplitude, in deg, defined in Ch 4, Sec 2, [2.1]

$C_{ZP}, C_{ZR}$  = Load combination factor defined in Ch 4, Sec 4, [2.2]

$F$  = Force, in kg, defined in Ch 6, Sec 1, [2.7.3]

$\lambda_S$  = Coefficient defined in Table 3

$\phi$  = Angle, in deg, defined in [3.2.3].

### 2.5.3 Ordinary stiffeners located on bilge hopper sloping plate or inner hull plate

The net section modulus  $w$ , in  $\text{cm}^3$ , and the net shear sectional area  $A_{sh}$ , in  $\text{cm}^2$ , of single span ordinary stiffeners located on hopper sloping plate and inner hull plate are to be not less than the values obtained from

the following formulae:

$$w = K_3 \frac{a_{\text{hopper}} F'}{8\lambda_S R_Y}$$

$$A_{sh} = \frac{5a_{\text{hopper}} F'}{\tau_a \sin \phi} 10^{-3}$$

where:

- $K_3$  = Coefficient defined in Table 1. When  $n_2 > 10$ ,  $K_3$  is taken equal to  $2\ell/3$
- $\theta_h$  = Angle, in deg, between inner bottom plate and bilge hopper sloping plate or inner hull plate
- $a_{\text{hopper}}$  = Acceleration, in  $\text{m/s}^2$ , defined in Ch 6 Sec 1, [2.7.4]
- $F'$  = Force, in kg, defined in Ch 6, Sec 1, [2.7.4]
- $\lambda_S$  = Coefficient defined in Table 3
- $\phi$  = Angle, in deg, defined in [3.2.3]
- $\ell'$  = Distance, in m, between outermost load points per elementary plate panel in ship length.

$n_2$	1	2	3	4	5	6	7	8	9	10
$K_3$	$\ell$	$\ell - \frac{\ell'^2}{\ell}$	$\ell - \frac{2\ell'^2}{3\ell}$	$\ell - \frac{5\ell'^2}{9\ell}$	$\ell - \frac{\ell'^2}{2\ell}$	$\ell - \frac{7\ell'^2}{15\ell}$	$\ell - \frac{4\ell'^2}{9\ell}$	$\ell - \frac{3\ell'^2}{7\ell}$	$\ell - \frac{5\ell'^2}{12\ell}$	$\ell - \frac{11\ell'^2}{27\ell}$

#### 2.5.4

Void.

### 2.6 Deck ordinary stiffeners in way of launching appliances used for survival craft or rescue boat

#### 2.6.1

The scantlings of deck ordinary stiffeners are to be determined by direct calculations.

#### 2.6.2

The loads exerted by launching appliance are to correspond to the Safe Working Load of the launching appliance.

#### 2.6.3

The combined stress, in  $\text{N/mm}^2$ , is not to exceed the smaller of:

$$\frac{100}{235} R_{eH} \quad \text{and} \quad \frac{54}{235} R_m$$

where  $R_m$  is the ultimate tensile strength of the stiffener material, in  $\text{N/mm}^2$ .

## 3 Yielding check

### 3.1 Load model

#### 3.1.1 General

The still water and wave lateral loads induced by the sea and the various types of cargoes and ballast in intact conditions are to be considered, depending on the location of the ordinary stiffener under consideration and the type of the compartments adjacent to it.

Ordinary stiffeners located on plating which constitutes the boundary of compartments not intended to carry liquids (excluding those on bottom and side shell plating) are to be subjected to the lateral pressure in flooded conditions.

The wave lateral loads and hull girder loads are to be calculated, for the probability level of  $10^{-8}$ , in the mutually exclusive load cases H1, H2, F1, F2, R1, R2, P1 and P2, as defined in Ch 4, Sec 4.



### 3.1.2 Lateral pressure in intact conditions

The lateral pressure in intact conditions is constituted by still water pressure and wave pressure.

Still water pressure  $p_S$  includes:

- the hydrostatic pressure, defined in Ch 4, Sec 5, [1]
- the still water internal pressure, defined in Ch 4, Sec 6 for the various types of cargoes and for ballast.

Wave pressure  $p_W$  includes for each load case H1, H2, F1, F2, R1, R2, P1 and P2:

- the hydrodynamic pressure, defined in Ch 4, Sec 5, [1]
- the inertial pressure, defined in Ch 4, Sec 6 for the various types of cargoes and for ballast.

### 3.1.3 Lateral pressure in flooded conditions

The lateral pressure in flooded conditions  $p_F$  is defined in Ch 4, Sec 6, [3.2.1].

### 3.1.4 Lateral pressure in testing conditions

The lateral pressure  $p_T$  in testing conditions is taken equal to:

- $p_T = p_{ST} - p_S$  for bottom shell plating and side shell plating
- $p_T = p_{ST}$  otherwise,

where:

$p_{ST}$  = Testing pressure defined in Ch 4, Sec 6, [4]

$p_S$  = Pressure taken equal to:

- if the testing is carried out afloat: hydrostatic pressure defined in Ch 4, Sec 5, [1] for the draught  $T_1$ , defined by the Designer, at which the testing is carried out. If  $T_1$  is not defined, the testing is considered as being not carried out afloat
- if the testing is not carried out afloat:  $p_S = 0$ .

### 3.1.5 Normal stresses

The normal stress to be considered for the strength check of ordinary stiffeners contributing to the hull girder longitudinal strength is the maximum value of  $\sigma_X$  between sagging and hogging conditions, when applicable, obtained, in N/mm<sup>2</sup>, from the following formula:

$$\sigma_X = \left[ C_{SW} \left| \frac{M_{SW}}{I_Y} \right| (z - N) + C_{WV} \left| \frac{M_{WV}}{I_Y} \right| (z - N) - C_{WH} \left| \frac{M_{WH}}{I_Z} \right| y \right] 10^{-3}$$

where:

- $M_{SW}$  = Permissible still water bending moments, in kN.m, in hogging or sagging as the case may be
- $M_{WV}$  = Vertical wave bending moment, in kN.m, in hogging or sagging as the case may be, as defined in Ch 4, Sec 3
- $M_{WH}$  = Horizontal wave bending moment, in kN.m, as defined in Ch 4, Sec 3
- $C_{SW}$  = Combination factor for each load case H1, H2, F1, F2, R1, R2, P1 and P2 and defined in Table 2
- $C_{WV}, C_{WH}$  = Combination factors defined in Ch 4, Sec 4, [2.2] for each load case H1, H2, F1, F2, R1, R2, P1 and P2 and given in Table 2.

LC	Hogging			Sagging		
	$C_{SW}$	$C_{WV}$	$C_{WH}$	$C_{SW}$	$C_{WV}$	$C_{WH}$
H1	Not Applicable			-1	-1	0
H2	1	1	0	Not Applicable		
F1	Not Applicable			-1	-1	0
F2	1	1	0	Not Applicable		
R1	1	0	$1.2 - \frac{T_{LC}}{T_S}$	-1	0	$1.2 - \frac{T_{LC}}{T_S}$
R2	1	0	$\frac{T_{LC}}{T_S} - 1.2$	-1	0	$\frac{T_{LC}}{T_S} - 1.2$
P1	1	$0.4 - \frac{T_{LC}}{T_S}$	0	-1	$0.4 - \frac{T_{LC}}{T_S}$	0
P2	1	$\frac{T_{LC}}{T_S} - 0.4$	0	-1	$\frac{T_{LC}}{T_S} - 0.4$	0

### 3.2 Strength criteria for single span ordinary stiffeners other than side frames of single side bulk carriers

#### 3.2.1 Boundary conditions

The requirements of this sub-article apply to ordinary stiffeners considered as clamped at both ends.

For other boundary conditions, the yielding check is to be considered on a case by case basis.

#### 3.2.2 Groups of equal ordinary stiffeners

Where a group of equal ordinary stiffeners is fitted, it is acceptable that the minimum net section modulus in [3.2.3] to [3.2.7] is calculated as the average of the values required for all the stiffeners of the same group, but this average is to be taken not less than 90% of the maximum required value.

The same applies for the minimum net shear sectional area.

#### 3.2.3 Net section modulus and net shear sectional area of single span ordinary stiffeners under intact conditions

The net section modulus  $w$ , in  $\text{cm}^3$ , and the net shear sectional area  $A_{sh}$ , in  $\text{cm}^2$ , of single span ordinary stiffeners subjected to lateral pressure are to be not less than the values obtained from the following formulae:

$$w = \frac{(p_S + p_W)s\ell^2}{m\lambda_S R_Y} 10^3$$

$$A_{sh} = \frac{5(p_S + p_W)s\ell}{\tau_a \sin \phi}$$

where:

$\lambda_S$  = Coefficient defined in Table 3.

$\phi$  = Angle, in deg, between the stiffener web and the shell plate, measured at the middle of the stiffener span; the correction is to be applied when  $\phi$  is less than 75 deg.

Ordinary stiffener	Coefficient $\lambda_S$
Longitudinal stiffener contributing to the hull girder longitudinal strength	$1.2 \left( 1.0 - 0.85 \left  \frac{\sigma_X}{R_Y} \right  \right)$ , without being taken greater than 0.9
Other stiffeners	0.9

### 3.2.4 Net section modulus of corrugated bulkhead of ballast hold for ships having a length $L$ less than 150 m

The net section modulus  $w$ , in  $\text{cm}^3$ , of corrugated bulkhead of ballast hold for ships having a length  $L$  less than 150 m subjected to lateral pressure are to be not less than the values obtained from the following formula:

$$w = K \frac{(p_S + p_W) S_C \ell^2}{m \lambda_S R_Y} 10^3$$

where:

$K$  = Coefficient given in Table 4 and 5, according to the type of end connection. When, both section modulus per half pitch of corrugated bulkhead and section modulus of lower stool at inner bottom are to be calculated.

$S_C$  = Half pitch length, in m, of the corrugation, defined in Ch 3, Sec 6, Fig 28

$\ell$  = Length, in m, between the supports, as indicated in Fig 6

$\lambda_S$  = Coefficient defined in Table 3.

The effective width of the corrugation flange in compression is to be considered according to Ch 3, Sec 6, [10.4.10] when the net section modulus of corrugated bulkhead is calculated.

Table 4 Values of $K$ , in case $d_H \geq 2.5d_0$		
Upper end support		
Supported by girders	Welded directly to deck	Welded to stool efficiently supported by ship structure
1.25	1.00	0.83

Table 5 Values of $K$ , in case $d_H < 2.5d_0$			
Section modulus of	Upper end support		
	Supported by girders	Connected to deck	Connected to stool
Corrugated bulkhead	0.83	0.71	0.65
Stool at bottom	0.83	1.25	1.13

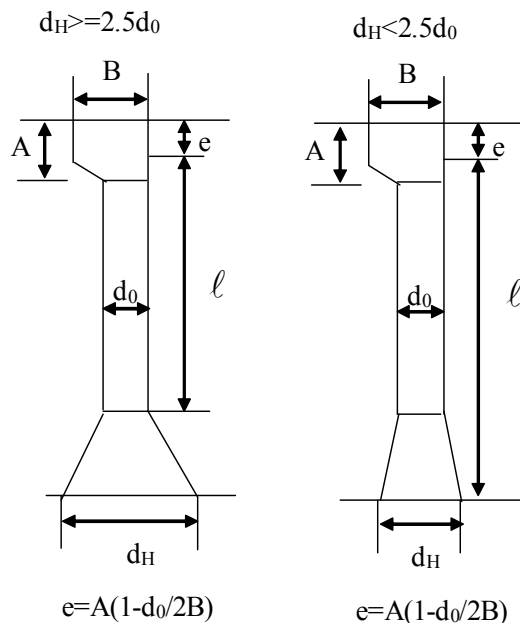

Fig. 6  
Measurement of  $\ell$

### 3.2.5 Net section modulus and net shear sectional area of single span ordinary stiffeners under flooded conditions excluding corrugations of transverse vertically corrugated bulkhead separating cargo holds

The net section modulus  $w$ , in  $\text{cm}^3$ , and the net shear sectional area  $A_{sh}$ , in  $\text{cm}^2$ , of single span ordinary stiffeners excluding corrugations of transverse vertically corrugated bulkhead separating cargo holds subjected to flooding are to be not less than the values obtained from the following formulae:

$$w = \frac{p_F s \ell^2}{16 \alpha \lambda_S R_Y} 10^3$$

$$A_{sh} = \frac{5 p_F s \ell}{\alpha \tau_a \sin \phi}$$

where:

$\lambda_S, \phi$  = Coefficient and angle defined in [3.2.3],  $\lambda_S$  being determined by considering  $\sigma_X$  in flooded condition.

$\alpha$  = Coefficient taken equal to:

$\alpha = 0.95$  for the ordinary stiffeners of collision bulkhead,

$\alpha = 1.15$  for the ordinary stiffeners of other watertight boundaries of compartments without taken  $\alpha \lambda_S$  greater than 1.0.

### 3.2.6 (Void)

### 3.2.7 Net section modulus and net shear sectional area of single span ordinary stiffeners under testing conditions

The net section modulus  $w$ , in  $\text{cm}^3$ , and the net shear sectional area  $A_{sh}$ , in  $\text{cm}^2$ , of single span ordinary stiffeners subjected to testing are to be not less than the values obtained from the following formulae:

$$w = \frac{p_T s \ell^2}{1.05 m R_Y} 10^3$$

$$A_{sh} = \frac{5 p_T s \ell}{1.05 \tau_a \sin \phi}$$

where:

$\phi$  = Angle, in deg, defined in [3.2.3].

## 3.3 Strength criteria for side frames of single side bulk carriers

### 3.3.1 Net section modulus and net shear sectional area of side frames

The net section modulus  $w$ , in  $\text{cm}^3$ , and the net shear sectional area  $A_{sh}$ , in  $\text{cm}^2$ , of side frames subjected to lateral pressure are to be not less, in the mid-span area, than the values obtained from the following formulae:

$$w = 1.125 \alpha_m \frac{(p_S + p_W) s \ell^2}{m \lambda_S R_Y} 10^3$$

$$A_{sh} = 1.1 \alpha_S \frac{5(p_S + p_W) s \ell \left( \frac{\ell - 2 \ell_B}{\ell} \right)}{\tau_a \sin \phi}$$

where:

$\alpha_m$  = Coefficient taken equal to:

$\alpha_m = 0.42$  for **BC-A** ships

$\alpha_m = 0.36$  for other ships

$\lambda_S$  = Coefficient taken equal to 0.9

$\ell$  = Side frame span, in m, defined in Ch 3, Sec 6, Fig 19, to be taken not less than  $0.25D$

$\alpha_S$  = Coefficient taken equal to:

$\alpha_S = 1.0$  for other side frames

$\alpha_S = 1.1$  for side frames of holds specified to be empty in **BC-A** ships

$\ell_B$  = Lower bracket length, in m, defined in Fig 7.

$p_s, p_w$  = Still water and wave pressures, in  $\text{kN/m}^2$ , in intact conditions calculated as defined in [1.3] and [1.4.2].

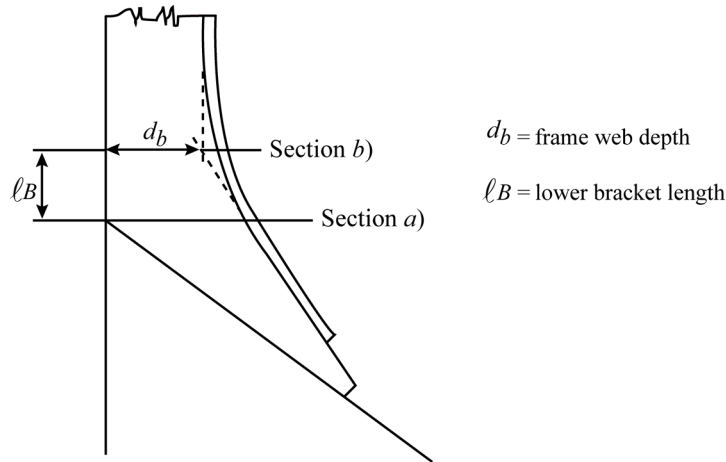

**Fig. 7**  
**Side frame lower bracket length**

In addition, for side frames of holds intended to carry ballast water in heavy ballast condition, the net section modulus  $w$ , in  $\text{cm}^3$ , and the net shear sectional area  $A_{sh}$ , in  $\text{cm}^2$ , all along the span are to be in accordance with [3.2.3],  $\ell$  being the span of the side frame as defined in Ch.3 Sec.6 [4.2], with consideration to brackets at ends.

### 3.3.2 Supplementary strength requirements

In addition to [3.3.1], the net moment of inertia, in  $\text{cm}^4$ , of the 3 side frames located immediately abaft the collision bulkhead is to be not less than the value obtained from the following formula:

$$I = 0.18 \frac{(p_s + p_w) \ell^4}{n}$$

where:

$\ell$  = Side frame span, in m

$n$  = Number of frames from the bulkhead to the frame in question, taken equal to 1, 2 or 3

As an alternative, supporting structures, such as horizontal stringers, are to be fitted between the collision bulkhead and a side frame which is in line with transverse webs fitted in both the topside tank and hopper tank, maintaining the continuity of forepeak stringers within the foremost hold.

### 3.3.3 Lower bracket of side frame

At the level of lower bracket as shown in Ch 3, Sec 6, Fig 19, the net section modulus of the frame and bracket, or integral bracket, with associated shell plating, is to be not less than twice the net section modulus  $w$  required for the frame mid-span area obtained from [3.3.1].

In addition, for holds intended to carry ballast water in heavy ballast condition, the net section modulus  $w$ , in  $\text{cm}^3$ , at the level of lower bracket is to be not less than twice the greater of the net sections moduli obtained from [3.3.1] and [3.2.3].

The net thickness  $t_{LB}$  of the frame lower bracket, in mm, is to be not less than the net thickness of the side frame web plus 1.5 mm.

Moreover, the net thickness  $t_{LB}$  of the frame lower bracket is to comply with the following formula:

— for symmetrically flanged frames:

$$\frac{h_{LB}}{t_{LB}} \leq 87\sqrt{k}$$

— for asymmetrically flanged frames :

$$\frac{h_{LB}}{t_{LB}} \leq 73\sqrt{k}$$

The web depth  $h_{LB}$  of lower bracket may be measured from the intersection between the sloped bulkhead of the hopper tank and the side shell plate, perpendicularly to the face plate of the lower bracket (see Ch 3, Sec 6, Fig 22).

For the 3 side frames located immediately abaft the collision bulkhead, whose scantlings are increased according to [3.3.2], when  $t_{LB}$  is greater than  $1.73t_w$ , the thickness  $t_{LB}$  may be taken as the value  $t'_{LB}$  obtained from the following formula:

$$t'_{LB} = (t_{LB}^2 t_w)^{1/3}$$

where  $t_w$  is the net thickness of the side frame web, in mm, corresponding to  $A_{Sh}$  determined in accordance to [3.3.1].

The flange outstand is not to exceed  $12k^{0.5}$  times the net flange thickness.

### 3.3.4 Upper bracket of side frame

At the level of upper bracket as shown in Ch 3, Sec 6, Fig 19, the net section modulus of the frame and bracket, or integral bracket, with associated shell plating, is to be not less than twice the net section modulus  $w$  required for the frame mid-span area obtained from [3.3.1].

In addition, for holds intended to carry ballast water in heavy ballast condition, the net section modulus  $w$ , in  $\text{cm}^3$ , at the level of upper bracket is not to be less than twice the greater of the net sections moduli obtained from [3.2.3] and [3.3.1].

The net thickness  $t_{UB}$  of the frame upper bracket, in mm, is to be not less than the net thickness of the side frame web.

## 3.4 Upper and lower connections of side frames of single side bulk carriers

### 3.4.1

The section moduli of the:

- side shell and hopper tank longitudinals that support the lower connecting brackets,
- side shell and topside tank longitudinals that support the upper connecting brackets

are to be such that the following relationship is separately satisfied for each lower and upper connecting bracket (see also Ch 3, Sec 6, Fig 22):

$$\sum_n w_i d_i \geq \alpha_T \frac{(p_S + p_W) \ell^2 \ell_1^2}{16R_Y}$$

where:

- $n$  = Number of the longitudinal stiffeners of side shell and hopper / topside tank that support the lower / upper end connecting bracket of the side frame, as applicable
- $w_i$  = Net section modulus, in  $\text{cm}^3$ , of the  $i$ -th longitudinal stiffener of the side shell or hopper / topside tank that support the lower / upper end connecting bracket of the side frame, as applicable
- $d_i$  = Distance, in m, of the above  $i$ -th longitudinal stiffener from the intersection point of the side shell and hopper /topside tank
- $\ell_1$  = Spacing, in m, of transverse supporting webs in hopper / topside tank, as applicable
- $R_Y$  = Lowest value of equivalent yield stress, in  $\text{N/mm}^2$ , among the materials of the longitudinal stiffeners of side shell and hopper / topside tanks that support the lower / upper end connecting bracket of the side frame
- $\alpha_T$  = Coefficient taken equal to:
  - $\alpha_T = 150$  for the longitudinal stiffeners supporting the lower connecting brackets
  - $\alpha_T = 75$  for the longitudinal stiffeners supporting the upper connecting brackets

$\ell$  = Side frame span, in m, as defined in [3.3.1].

$p_S, p_W$  = Still water and wave pressures as those for the side frame.

### 3.4.2

The net connection area,  $A_i$ , in  $\text{cm}^2$ , of the bracket to the  $i$ -th longitudinal stiffener supporting the bracket is to

be obtained from the following formula:

$$A_i = 0.4 \frac{w_i s}{\ell_1^2} \frac{k_{bkt}}{k_{lg,i}}$$

where:

$w_i$  = Net section modulus, in cm<sup>3</sup>, of the i-th longitudinal stiffener of the side or sloped bulkheads that support the lower or the upper end connecting bracket of the side frame, as applicable

$\ell_1$  = As defined in [3.4.1]

$k_{bkt}$  = Material factor for the bracket

$k_{lg,i}$  = Material factor for the i-th longitudinal stiffener.

$s$  = Frame spacing, in m.

### 3.5 Strength criteria for multi-span ordinary stiffeners

#### 3.5.1 Checking criteria

The maximum normal stress  $\sigma$  and shear stress  $\tau$  in a multi-span ordinary stiffener, calculated according to [3.5.2], are to comply with the formulae in Table 6.

Table 6 Checking criteria for multi-span ordinary stiffeners			
Condition	Intact	Flooded	Testing
Normal stress	$\sigma \leq \lambda_s R_Y$	$\sigma \leq \alpha \lambda_s R_Y$	$\sigma \leq 1.05 R_Y$
Shear stress	$\tau \leq \tau_a$	$\tau \leq \alpha \tau_a$	$\tau \leq 1.05 \tau_a$
Note 1: $\lambda_s$ = Coefficient defined in [3.2.3] $\alpha$ = Coefficient defined in [3.2.5]			

#### 3.5.2 Multi-span ordinary stiffeners

The maximum normal stress  $\sigma$  and shear stress  $\tau$  in a multi-span ordinary stiffener are to be determined by a direct calculation taking into account:

- the distribution of still water and wave pressure and forces, if any
- the number and position of intermediate supports (decks, girders, etc.)
- the condition of fixity at the ends of the stiffener and at intermediate supports
- the geometrical characteristics of the stiffener on the intermediate spans.

### 3.6 Scantlings of transverse vertically corrugated watertight bulkheads separating cargo holds for flooded conditions

#### 3.6.1 Bending capacity and shear capacity of the corrugations of transverse vertically corrugated watertight bulkheads separating cargo holds

The bending capacity and the shear capacity of the corrugations of watertight bulkheads between separating cargo holds are to comply with the following formulae:

$$0.5W_{LE} + W_M \geq \frac{M}{0.95R_{eH}} 10^3$$

$$\tau \leq \frac{R_{eH}}{2}$$

where:

$M$  = Bending moment in a corrugation, to be obtained, in kN.m, from the following formula:

$$M = F \ell_C / 8$$

$F$  = Resultant force, in kN, to be calculated according to Ch 4, Sec 6, [3.3.7]

$\ell_C$  = Span of the corrugations, in m, to be obtained according to [3.6.2]

$W_{LE}$  = Net section modulus, in cm<sup>3</sup>, of one half pitch corrugation, to be calculated at the lower end of the corrugations according to [3.6.2], without being taken greater than the value obtained from the

following formula:

$$W_{LE,M} = W_G + \left( \frac{Q h_G - 0.5 h_G^2 s_C p_G}{R_{eH}} \right) 10^3$$

$W_G$  = Net section modulus, in cm<sup>3</sup>, of one half pitch corrugation, to be calculated in way of the upper end of shedder or gusset plates, as applicable, according to [3.6.2]

$Q$  = Shear force at the lower end of a corrugation, to be obtained, in kN, from the following formula:

$$Q = 0.8F$$

$h_G$  = Height, in m, of shedders or gusset plates, as applicable (see Fig 11 to Fig 15)

$p_G$  = Resultant pressure, in kN/m<sup>2</sup>, to be calculated in way of the middle of the shedders or gusset plates, as applicable, according to Ch 4, Sec 6, [3.3.7]

$s_C$  = Spacing of the corrugations, in m, to be taken according to Ch 3, Sec 6, Fig 28

$W_M$  = Net section modulus, in cm<sup>3</sup>, of one half pitch corrugation, to be calculated at the mid-span of corrugations according to [3.6.2] without being taken greater than 1.15  $W_{LE}$

$\tau$  = Shear stress in the corrugation, in N/mm<sup>2</sup>, to be obtained from the following formula:

$$\tau = 10 \frac{Q}{A_{sh}}$$

$A_{sh}$  = Shear area, in cm<sup>2</sup>, calculated according to the followings.

The shear area is to be reduced in order to account for possible non-perpendicular between the corrugation webs and flanges. In general, the reduced shear area may be obtained by multiplying the web sectional area by (sin  $\varphi$ ),  $\varphi$  being the angle between the web and the flange (see Ch 3, Sec 6, Fig 28).

The actual net section modulus of corrugations is to be calculated according to [3.6.2].

The net section modulus of the corrugations upper part of the bulkhead, as defined in Sec 1, Fig 5, is to be not less than 75% of that of the middle part complying with this requirement and Sec 1, [3.2.1], corrected for different minimum yield stresses.

### 3.6.2 Net Section modulus at the lower end of corrugations

a) The net section modulus at the lower end of corrugations (Fig 11 to Fig 15) is to be calculated with the compression flange having an effective flange width  $b_{ef}$  not larger than that indicated in Ch 3, Sec 6, [10.4.10]

b) Webs not supported by local brackets

Except in case e), if the corrugation webs are not supported by local brackets below the stool top plate (or below the inner bottom) in the lower part, the section modulus of the corrugations is to be calculated considering the corrugation webs 30% effective.

c) Effective shedder plates

Provided that effective shedder plates, as defined in Ch 3, Sec 6, [10.4.11] are fitted (see Fig 11 and Fig 12), when calculating the section modulus of corrugations at the lower end (cross sections 1 in Fig 11 and Fig 12), the net area of flange plates may be increased by the value obtained, in cm<sup>2</sup>, from the following formula:

$$I_{SH} = 2.5a \sqrt{t_f t_{SH}}$$

without being taken greater than  $2.5at_f$ ,

where:

$a$  = Width, in m, of the corrugation flange (see Ch 3, Sec 6, Fig 28)

$t_{SH}$  = Net shedder plate thickness, in mm

$t_f$  = Net flange thickness, in mm.

d) Effective gusset plates

Provided that effective gusset plates, as defined in Ch 3, Sec 6, [10.4.12], are fitted (see Fig 13 to Fig 15), when calculating the net section modulus of corrugations at the lower end (cross-sections 1 in Fig 13 to Fig 15), the area of flange plates may be increased by the value obtained, in cm<sup>2</sup>, from the following formula:

$$I_G = 7h_G t_f$$

where:

$h_G$  = Height, in m, of gusset plates (see Fig 13 to Fig 15), to be taken not greater than  $(10/7)S_{GU}$



$S_{GU}$  = Width, in m, of gusset plates  
 $t_f$  = Net flange thickness, in mm.

e) Sloping stool top plate

If the corrugation webs are welded to a sloping stool top plate which has an angle not less than 45° with the horizontal plane, the section modulus of the corrugations may be calculated considering the corrugation webs fully effective. For angles less than 45°, the effectiveness of the web may be obtained by linear interpolation between 30% for 0° and 100% for 45°.

Where effective gusset plates are fitted, when calculating the net section modulus of corrugations the net area of flange plates may be increased as specified in d) above. No credit may be given to shedder plates only.

### 3.6.3 Stiffeners in lower stool and upper stool

The net section modulus of stiffeners in lower stool and upper stool is to be greater of the values obtained from the following formula or required by [3.2.5].

$$w = \frac{ps\ell^2}{16\alpha\lambda_s R_Y} 10^3$$

Where

$p$  = Pressure, in kN/m<sup>2</sup>, as defined in Ch 4 Sec 6, [3.3.7]  
 $\alpha$  and  $\lambda_s$  = defined in [3.2.5]

## 4 Web stiffeners of primary supporting members

### 4.1 Net scantlings

#### 4.1.1

Where primary supporting member web stiffeners are welded to ordinary stiffener face plates, their net sectional area at the web stiffener mid-height is to be not less than the value obtained, in cm<sup>2</sup>, from the following formula:

$$A = 0.1k_1ps\ell$$

where:

$k_1$  = Coefficient depending on the web connection with the ordinary stiffener, to be taken as:

$k_1$  = 0.30 for connections without collar plate (see Ch 3, Sec 6, Fig 8)  
 $k_1$  = 0.225 for connections with a collar plate (see Ch 3, Sec 6, Fig 9)  
 $k_1$  = 0.20 for connections with one or two large collar plates (see Ch 3, Sec 6, Fig 10 and 11)

$p$  = Pressure, in kN/m<sup>2</sup>, acting on the ordinary stiffener.

#### 4.1.2

The net section modulus of web stiffeners of non-watertight primary supporting members is to be not less than the value obtained, in cm<sup>3</sup>, from the following formula:

$$w = 2.5s^2tS_S^2$$

where:

$s$  = Length, in m, of web stiffeners  
 $t$  = Web net thickness, in mm, of the primary supporting member  
 $S_S$  = Spacing, in m, of web stiffeners.

#### 4.1.3 Connection ends of web stiffeners

Where the web stiffeners of primary supporting members are welded to ordinary stiffener face plates, the stress at ends of web stiffeners of primary supporting members in water ballast tanks, in N/mm<sup>2</sup>, is to comply with the following formula when no bracket is fitted:

$$\sigma \leq 175$$

where:

$$\sigma = 1.1K_{con}K_{longi}K_{stiff} \frac{\Delta\sigma}{\cos\theta}$$

- $K_{con}$  = Coefficient considering stress concentration, taken equal to:  
 $K_{con} = 3.5$  for stiffeners in the double bottom or double side space (see Fig 8)  
 $K_{con} = 4.0$  for other cases (e.g. hopper tank, top side tank, etc.) (see Fig 8)
- $K_{longi}$  = Coefficient considering shape of cross section of the longitudinal, taken equal to:  
 $K_{longi} = 1.0$  for symmetrical profile of stiffener (e.g. T-section, flat bar)  
 $K_{longi} = 1.3$  for asymmetrical profile of stiffener (e.g. angle section, bulb profile)
- $K_{stiff}$  = Coefficient considering the shape of the end of the stiffener, taken equal to:  
 $K_{stiff} = 1.0$  for standard shape of the end of the stiffener (see Fig 9)  
 $K_{stiff} = 0.8$  for the improved shape of the end of the stiffener (see Fig 9)
- $\theta$  = As given in Fig 10
- $\Delta\sigma$  = Stress range, in N/mm<sup>2</sup>, transferred from longitudinals into the end of web stiffener, as obtained from the following formula:
- $$\Delta\sigma = \frac{2W}{0.322h'[(A_{w1}/\ell_1) + (A_{w2}/\ell_2)] + A_{s0}}$$
- $W$  = Dynamic load, in N, as obtained from the following formula:  
 $W = 1000(\ell - 0.5s)sp$
- $p$  = Maximum inertial pressure due to liquid in the considered compartment where the web stiffener is located according to Ch 4, Sec 6, [2.2.1], in kN/m<sup>2</sup>, of the probability level of 10<sup>-4</sup>, calculated at mid-span of the ordinary stiffener
- $\ell$  = Span of the longitudinal, in m
- $s$  = Spacing of the longitudinal, in m
- $A_{s0}, A_{w1}, A_{w2}$  = Geometric parameters as given in Fig 10, in mm<sup>2</sup>
- $\ell_1, \ell_2$  = Geometric parameters as given in Fig 10, in mm
- $h'$  = As obtained from following formula, in mm:  
 $h' = h_s + h_0'$
- $h_s$  = As given in Fig 10, in mm
- $h_0'$  = As obtained from the following formula, in mm  
 $h_0' = 0.636b'$  for  $b' \leq 150$   
 $h_0' = 0.636b' + 63$  for  $150 < b'$
- $b'$  = Smallest breadth at the end of the web stiffener, in mm, as shown in Fig 9

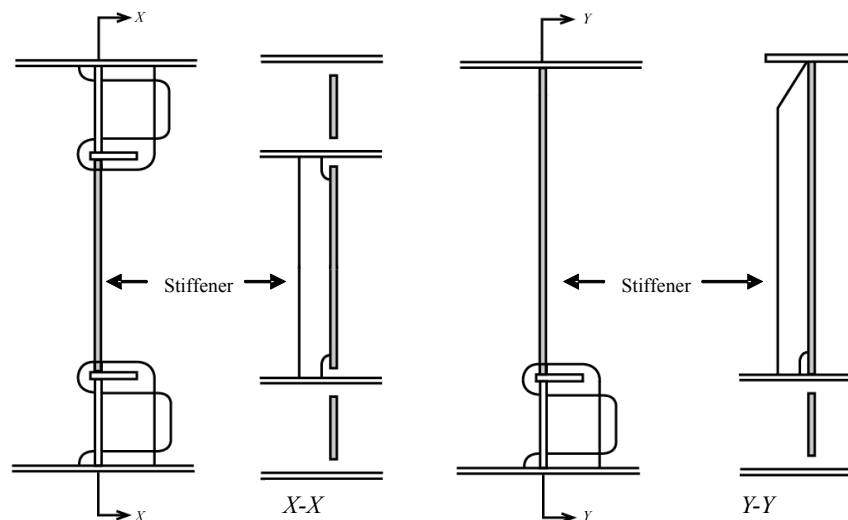
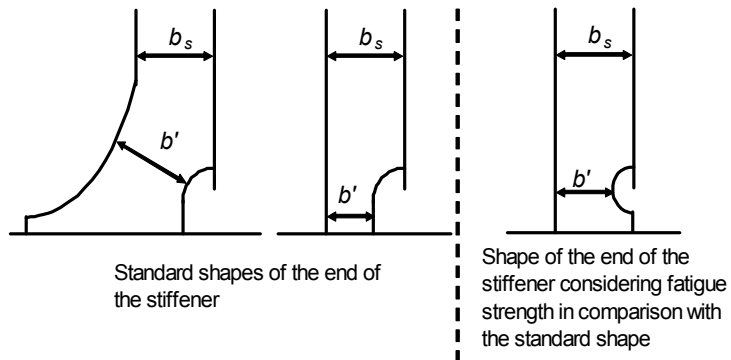
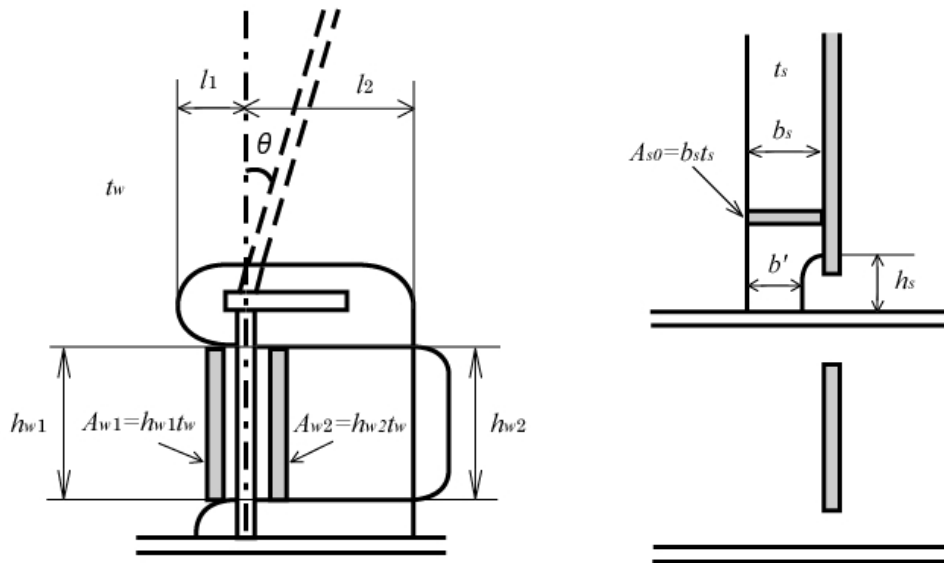

Fig. 8  
Web stiffeners fitted on primary supporting members



**Fig. 9**  
Shape of the end of the web stiffener



Note:

$t_s$  = net thickness of the web stiffener, in mm.

$t_w$  = net thickness of the collar plate, in mm.

**Fig. 10**  
Definitions of geometric parameters

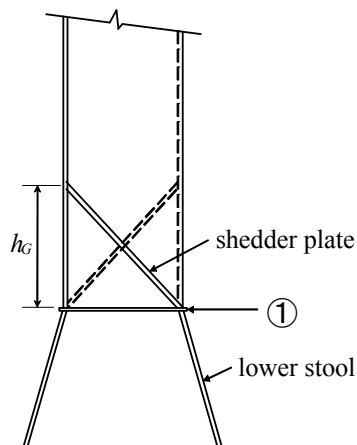

**Fig. 11**  
Symmetrical shedder plates

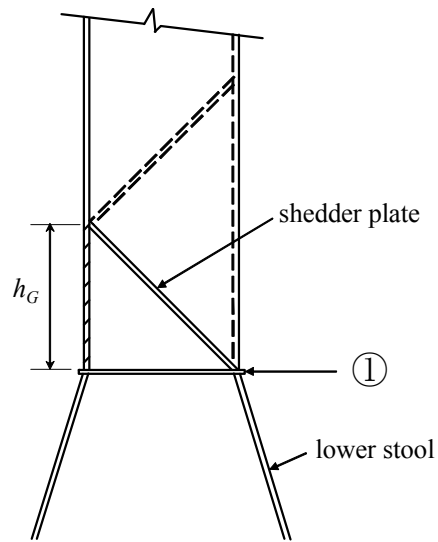

**Fig. 12**  
Asymmetrical shedder plates

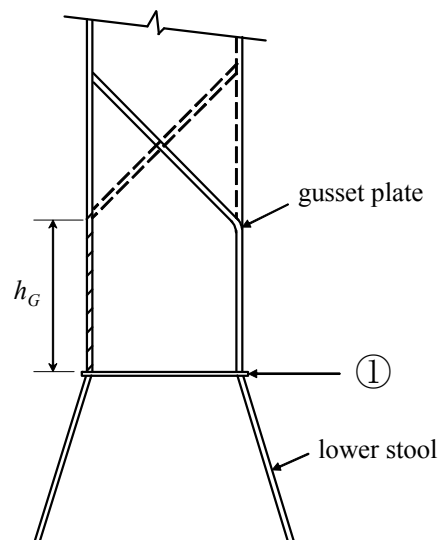

**Fig. 13**  
Symmetrical gusset/shedder plates

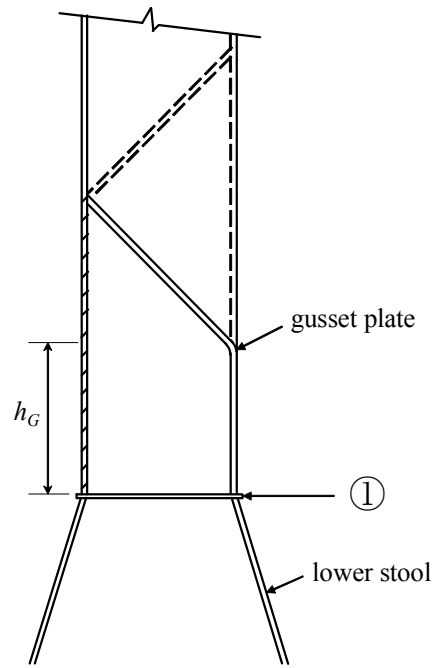

**Fig. 14**  
Asymmetrical gusset/shedder plates

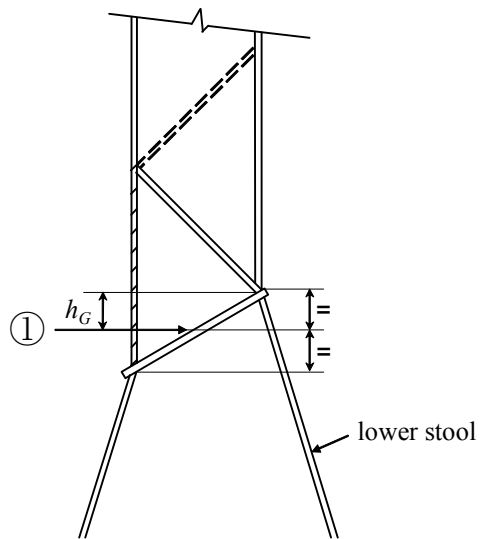

**Fig. 15**  
Asymmetrical gusset/shedder plates

## SECTION 3 BUCKLING AND ULTIMATE STRENGTH OF ORDINARY STIFFENERS AND STIFFENED PANELS

### Symbols

For symbols not defined in this Section, refer to Ch 1, Sec 4.

In this section, compressive and shear stresses are to be taken positive, tension stresses are to be taken negative.

$a$  = Length in mm of the longer side of the partial plate field in general or length in mm of the side of the partial plate field according Table 2, BLC 3 - 10

$b$  = Length in mm of the shorter side of the partial plate field in general or length in mm of the side of the partial plate field according Table 2, BLC 3 - 10

$\alpha$  = Aspect ratio of elementary plate panel, taken equal to:

$$\alpha = \frac{a}{b}$$

$n$  = Number of elementary plate panel breadths within the partial or total plate panel

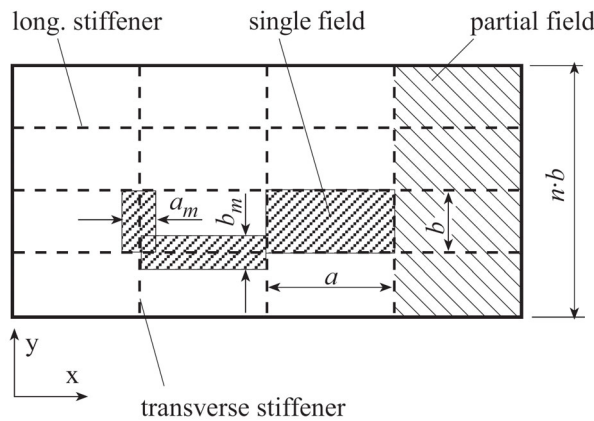

longitudinal : stiffener in the direction of the length  $a$   
transverse : stiffener in the direction of the breath  $b$

**Fig. 1**  
General arrangement of panel

$t$  = Net plate thickness, in mm

$\sigma_n$  = Normal stress resulting from hull girder bending, in N/mm<sup>2</sup>

$\tau_{SF}$  = Shear stress induced by the shear forces as defined in [2.1.3], in N/mm<sup>2</sup>

$\sigma_x$  = Membrane stress in  $x$ -direction, in N/mm<sup>2</sup>

$\sigma_y$  = Membrane stress in  $y$ -direction, in N/mm<sup>2</sup>

$\tau$  = Shear stress in the  $x$ - $y$  plane, in N/mm<sup>2</sup>

$\lambda$  = Reference degree of slenderness, taken equal to:

$$\lambda = \sqrt{\frac{R_{eH}}{K\sigma_e}}$$

$K$  = Buckling factor according to Table 2 and Table 3

Reference stress, to be the following for LC 1 and 2:

$\sigma_e$  = Reference stress, taken equal to:

$$\sigma_e = 0.9E \left( \frac{t}{b'} \right)^2$$

$b'$  = shorter side of elementary plate panel

Reference stress, to be the following for LC 3 through 10:

$\sigma_e$  = Reference stress, taken equal to:

$$\sigma_e = 0.9E \left( \frac{t}{b} \right)^2$$

$\psi$  = Edge stress ratio taken equal to :

$$\psi = \sigma_2 / \sigma_1$$

where:

$\sigma_1$  = maximum compressive stress

$\sigma_2$  = minimum compressive stress or tensile stress

$S$  = Safety factor, taken equal to:

$S$  = 1.0 except for the case mentioned below

$S$  = 1.1 for structures which are exclusively exposed to local loads (e.g. hatch covers, foundations)

$S$  = 1.15 for the ultimate strength in lateral buckling mode of longitudinal and transverse ordinary stiffeners of the hatchway coamings, sloping plating of the topside tanks and hopper tanks, inner bottom, inner side if any, side shell of single side skin construction and top and bottom stools of transverse bulkheads, assessed according to [4.2].

For constructions of aluminium alloys the safety factors are to be increased in each case by 0.1

$F_1$  = Correction factor for boundary condition of stiffeners on the longer side of elementary plate panels according to Table 1. If the clamping is unequal on the longitudinal sides of the panel, the minimum value of the appropriate  $F_1$ -parameter has to be used.

Table 1 Correction factor $F_1$		
	$F_1^{(2)}$	Edge stiffener
Stiffeners sniped at both ends	1.00	
Guidance values where both ends are effectively connected to adjacent structures <sup>(1)</sup>	1.05	Flat bar
	1.10	Bulb section
	1.20	Angle and tee-sections
	1.30	Girders of high rigidity (e.g. bottom transverses)
(1) Exact values may be determined by direct calculations.		
(2) An average value of $F_1$ is to be used for plate panels having different edge stiffeners.		

## 1 General

### 1.1

#### 1.1.1

The requirements of this Section apply for the buckling check of structural members subjected to compressive stresses, shear stresses and lateral pressure.

#### 1.1.2

The buckling checks have to be performed for the following elements:

- a) according to requirements of [2], [3] and [4] and for all load cases as defined in Ch 4, Sec 4 in intact condition:
  - elementary plate panels and ordinary stiffeners in a hull transverse section analysis,
  - elementary plate panels modeled in FEM as requested in Ch 7.
- b) according to requirements of [6] and only in flooded condition:
  - transverse vertically corrugated watertight bulkheads for **BC-A** and **BC-B** ships.

#### 1.1.3

The boundary condition for elementary plate panels are to be considered as simply supported. If the boundary condition differs significantly from simple support, more appropriate boundary condition can be applied

according to cases 3, 4 and 7 to 10 of Table 2.

## 2 Application

### 2.1 Load model for hull transverse section analysis

#### 2.1.1 General

The structural members at a considered hull transverse section are to be checked for buckling criteria under the combination of:

- the normal stress  $\sigma_n$  resulting from hull girder bending, as defined in [2.1.2]
- the shear stress  $\tau_{SF}$  as defined in [2.1.3]
- the lateral pressure in intact condition applied on the members as the case may be.

The lateral pressures and hull girder loads are to be calculated, for the probability level of  $10^{-8}$ , in the mutually exclusive load cases H1, H2, F1, F2, R1, R2, P1 and P2, as defined in Ch 4, Sec 4.

#### 2.1.2 Normal stress $\sigma_n$

The normal stress  $\sigma_n$  to be considered for each of the mutually exclusive load cases as referred in [2.1.1] is the maximum compressive stress on the considered structural member according to the formulas given in Ch 6, Sec 1, [3.1.5] and Ch 6, Sec 2, [3.1.5], respectively for elementary plate panels and ordinary stiffeners.

For transverse ordinary stiffeners, the normal stress  $\sigma_n$  for each of the mutually exclusive load cases is the maximum compressive stress calculated at each end.

#### 2.1.3 Shear stress

The shear stress  $\tau_{SF}$  to be considered for each of the mutually exclusive load cases as referred in [2.1.1] is the shear stress induced by the shear forces, in kN, equal to:

$$Q = Q_{SW} + C_{QW} Q_{WV}$$

where:

$Q_{SW}$  = Design still water shear force in intact condition, in kN, at the hull transverse section considered, defined in Ch 4, Sec 3, [2.3]

$Q_{WV}$  = Vertical wave shear force in intact condition, in kN, at the hull transverse section considered, defined in Ch 4, Sec 3, [3.2]

$C_{QW}$  = Load combination factor as defined in Ch 4, Sec 4, Table 3

If the design still water shear force is not available at preliminary design stage, the following default value, in kN, may be used:

$$Q_{SW0} = 30 CLB(C_B + 0.7)10^{-2}$$

#### 2.1.4 Lateral pressure

The lateral pressure to be considered for the buckling check is defined in Ch 6, Sec 1, [3.1] for curved plate panel and in Ch 6, Sec 2, [3.1] for ordinary stiffeners.

The load calculation point for the curved plate panel is located at mid distance of the curved plate panel extremities along the curve.

The load calculation point of ordinary stiffeners is defined in Ch 6, Sec 2, [1.4]



## 2.2 Application

### 2.2.1

Application of the buckling and ultimate strength criterion is described in App 1.

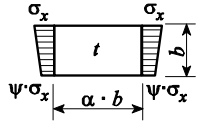
<b>Table 2 Buckling and reduction factors for plane elementary plate panels</b>				
<i>Buckling-Load Case</i>	<i>Edge stress ratio <math>\psi</math></i>	<i>Asp. ratio <math>\alpha = a/b</math></i>	<i>Buckling factor <math>K</math></i>	<i>Reduction factor <math>\kappa</math></i>
1 	$1 \geq \psi \geq 0$	$\alpha \geq 1$	$K = \frac{8.4}{\psi + 1.1}$	$K_x = 1$ for $\lambda \leq \lambda_c$ $\kappa_x = c \left( \frac{1}{\lambda} - \frac{0.22}{\lambda^2} \right)$ for $\lambda \leq \lambda_c$ $c = (1.25 - 0.12\psi) \leq 1.25$
	$0 > \psi > -1$		$K = 7.63 - \psi(6.26 - 10\psi)$	
	$\psi \leq -1$		$K = (1 - \psi)^2 \cdot 5.975$	$\lambda_c = \frac{c}{2} \left( 1 + \sqrt{1 - \frac{0.88}{c}} \right)$

Buckling-Load Case	Edge stress ratio $\psi$	Asp. ratio $\alpha = a/b$	Buckling factor $K$	Reduction factor $\kappa$
<p>2</p> 	$1 \geq \psi \geq 0$	$\alpha \geq 1$	$K = F_1 \left(1 + \frac{1}{\alpha^2}\right)^2 \frac{2.1}{(\psi + 1.1)}$	$\kappa_y = c \left( \frac{1}{\lambda} - \frac{R + F^2(H - R)}{\lambda^2} \right)$
	$0 > \psi > -1$	$1 \leq \alpha \leq 1.5$	$K = F_1 \left[ \left(1 + \frac{1}{\alpha^2}\right)^2 \frac{2.1(1 + \psi)}{1.1} - \frac{\psi}{\alpha^2} (13.9 - 10\psi) \right]$	$c = (1.25 - 0.12\psi) \leq 1.25$ $R = \lambda \left(1 - \frac{\lambda}{c}\right)$ for $\lambda < \lambda_c$
		$\alpha > 1.5$	$K = F_1 \left[ \left(1 + \frac{1}{\alpha^2}\right)^2 \frac{2.1(1 + \psi)}{1.1} - \frac{\psi}{\alpha^2} (5.87 + 1.87\alpha^2 + \frac{8.6}{\alpha^2} - 10\psi) \right]$	$R = 0.22$ for $\lambda \geq \lambda_c$ $\lambda_c = \frac{c}{2} \left(1 + \sqrt{1 - \frac{0.88}{c}}\right)$
	$\psi \leq -1$	$1 \leq \alpha \leq \frac{3(1 - \psi)}{4}$	$K = F_1 \left(\frac{1 - \psi}{\alpha}\right)^2 \cdot 5.975$	$F = \left(1 - \frac{\frac{K}{\lambda_p^2} - 1}{\lambda_p^2}\right) \cdot c_1 \geq 0$ $\lambda_p^2 = \lambda^2 - 0.5$ for $1 \leq \lambda_p^2 \leq 3$
		$\alpha > \frac{3(1 - \psi)}{4}$	$K = F_1 \left[ \left(\frac{1 - \psi}{\alpha}\right)^2 \cdot 3.9675 + 0.5375 \left(\frac{1 - \psi}{\alpha}\right)^4 + 1.87 \right]$	$c_1 = 1$ , for $\sigma_y$ due to direct loads $c_1 = \left(1 - \frac{F_1}{\alpha}\right) \geq 0$ for $\sigma_y$ due to bending (in general) $c_1 = 0$ , for $\sigma_y$ due to bending in extreme load cases (e.g. wt. bulkheads) $H = \lambda - \frac{2\lambda}{c(T + \sqrt{T^2 - 4})} \geq R$ $T = \lambda + \frac{14}{15\lambda} + \frac{1}{3}$

Table 2 Buckling and reduction factors for plane elementary plate panels (Continued)				
Buckling-Load Case	Edge stress ratio $\psi$	Asp. ratio $\alpha = a/b$	Buckling factor $K$	Reduction factor $\kappa$
<p>3</p> 	$1 \geq \psi \geq 0$	$\alpha > 0$	$K = \frac{4 \left( 0.425 + \frac{1}{\alpha^2} \right)}{3\psi + 1}$	$\kappa_x = 1$ for $\lambda \leq 0.7$
	$0 > \psi \geq -1$		$K = 4 \left( 0.425 + \frac{1}{\alpha^2} \right) (1 + \psi) - 5\psi(1 - 3.42\psi)$	
<p>4</p> 	$1 \geq \psi \geq -1$	$\alpha > 0$	$K = \left( 0.425 + \frac{1}{\alpha^2} \right) \frac{3 - \psi}{2}$	$\kappa_x = \frac{1}{\lambda^2 + 0.51}$ for $\lambda > 0.7$
<p>5</p> 	≡	$\alpha \geq 1$	$K = K_\tau \sqrt{3}$ $K_\tau = \left[ 5.34 + \frac{4}{\alpha^2} \right]$	$\kappa_\tau = 1$ for $\lambda \leq 0.84$
		$0 < \alpha < 1$	$K_\tau = \left[ 4 + \frac{5.34}{\alpha^2} \right]$	
<p>6</p> 	≡		$K = K' r$ $K' = K$ according to load case 5 $r = \left( 1 - \frac{d_a}{a} \right) \left( 1 - \frac{d_b}{b} \right)$ with $\frac{d_a}{a} \leq 0.7$ and $\frac{d_b}{b} \leq 0.7$	$\kappa_\tau = \frac{0.84}{\lambda}$ for $\lambda > 0.84$
<p>7</p> 	≡	$\alpha \geq 1.64$	$K = 1.28$	$\kappa_x = 1$ for $\lambda \leq 0.7$
		$\alpha < 1.64$	$K = \frac{1}{\alpha^2} + 0.56 + 0.13\alpha^2$	

Table 2 Buckling and reduction factors for plane elementary plate panels (Continued)				
Buckling-Load Case	Edge stress ratio $\psi$	Asp. ratio $\alpha = a/b$	Buckling factor $K$	Reduction factor $\kappa$
	==	$\alpha \geq \frac{2}{3}$	$K = 6.97$	$\kappa_x = 1$ for $\lambda \leq 0.83$  $\kappa_x = 1,13 \left[ \frac{1}{\lambda} - \frac{0.22}{\lambda^2} \right]$ for $\lambda > 0.83$
		$\alpha < \frac{2}{3}$	$K = \frac{1}{\alpha^2} + 2.5 + 5\alpha^2$	
	==	$\alpha \geq 4$	$K = 4$	
		$4 > \alpha > 1$	$K = 4 + \left[ \frac{4-\alpha}{3} \right]^4 \cdot 2.74$	
		$\alpha \leq 1$	$K = \frac{4}{\alpha^2} + 2.07 + 0.67\alpha^2$	
	==	$\alpha \geq 4$	$K = 6.97$	
		$4 > \alpha > 1$	$K = 6.97 + \left[ \frac{4-\alpha}{3} \right]^4 \cdot 3.1$	
		$\alpha \leq 1$	$K = \frac{4}{\alpha^2} + 2.07 + 4\alpha^2$	
Explanations for boundary conditions:		- - - - - plate edge free ——— plate edge simply supported ——— plate edge clamped		

Note: The load cases as listed in Table 2 are general cases. Each stress component ( $\sigma_x$ ,  $\sigma_y$ ) is to be understood in a local coordinates.

Table 3 Buckling and reduction factor for curved plate panel with $R/t \leq 2500$ <sup>1)</sup>			
Buckling-Load Case	Aspect ratio $a/b$	Buckling factor $K$	Reduction factor $\kappa$
1a 	$\frac{b}{R} \leq 1.63 \sqrt{\frac{R}{t}}$	$K = \frac{b}{\sqrt{Rt}} + 3 \frac{(Rt)^{0.175}}{b^{0.35}}$	$\kappa_x = 1$ for $\lambda \leq 0.4$ <sup>2)</sup>  $\kappa_x = 1.274 - 0.686 \cdot \lambda$ for $0.4 < \lambda \leq 1.2$
1b 			
$p_e = \text{external pressure in [N/mm}^2\text{]}$		$\kappa_x = \frac{0.65}{\lambda^2}$ for $\lambda > 1.2$	

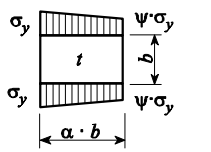
Table 3 Buckling and reduction factor for curved plate panel with $R/t \leq 2500$ <sup>1)</sup> (Continued)			
Buckling-Load Case	Aspect ratio $a/b$	Buckling factor $K$	Reduction factor $\kappa$
<p>2</p> 	$\frac{b}{R} \leq 0.5 \sqrt{\frac{R}{t}}$	$K = 1 + \frac{2 b^2}{3 R t}$	$\kappa_y = 1$ for $\lambda \leq 0.25$ <sup>2)</sup>  $\kappa_y = 1.233 - 0.933 \cdot \lambda$ for $0.25 < \lambda \leq 1$  $\kappa_y = 0.3 / \lambda^3$ for $1 < \lambda \leq 1.5$  $\kappa_y = 0.2 / \lambda^2$ for $\lambda > 1.5$
	$\frac{b}{R} > 0.5 \sqrt{\frac{R}{t}}$	$K = 0.267 \frac{b^2}{R t} \left[ 3 - \frac{b}{R} \sqrt{\frac{t}{R}} \right]$  $\geq 0.4 \frac{b^2}{R t}$	
<p>3</p> 	$\frac{b}{R} \leq \sqrt{\frac{R}{t}}$	$K = \frac{0.6 \cdot b}{\sqrt{R t}} + \frac{\sqrt{R t}}{b} - 0.3 \frac{R t}{b^2}$	as in load case 1a
	$\frac{b}{R} > \sqrt{\frac{R}{t}}$	$K = 0.3 \frac{b^2}{R^2} + 0.291 \left( \frac{R^2}{b t} \right)^2$	
<p>4</p> 	$\frac{b}{R} \leq 8.7 \sqrt{\frac{R}{t}}$	$K = K_\tau \sqrt{3}$  $K_\tau = \left[ 28.3 + \frac{0.67 b^3}{R^{1.5} t^{1.5}} \right]^{0.5}$	$\kappa_\tau = 1$ for $\leq 0.4$  $\kappa_\tau = 1.274 - 0.686 \cdot \lambda$ for $0.4 < \lambda \leq 1.2$  $\kappa_\tau = \frac{0.65}{\lambda^2}$ for $\lambda > 1.2$
	$\frac{b}{R} > 8.7 \sqrt{\frac{R}{t}}$	$K_\tau = 0.28 \frac{b^2}{R \sqrt{R t}}$	
Explanations for boundary conditions: <ul style="list-style-type: none"> <li>..... plate edge free</li> <li>———— plate edge simply supported</li> <li>———— plate edge clamped</li> </ul>			
<sup>1)</sup> For curved plate fields with a very large radius the $\kappa$ -value need not to be taken less than for the expanded plane field <sup>2)</sup> For curved single fields, e.g. bilge strake, which are located within plane partial or total fields, the reduction factor $\kappa$ may taken as follow: <div style="display: flex; justify-content: space-around; margin-top: 10px;"> <div style="text-align: center;">             Load case 1b: <math>\kappa_x = \frac{0.8}{\lambda^2} \leq 1,0</math> </div> <div style="text-align: center;">             Load case 2: <math>\kappa_y = \frac{0.65}{\lambda^2} \leq 1,0</math> </div> </div>			

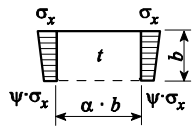
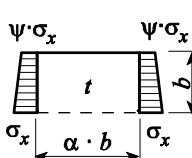
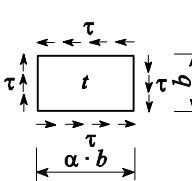
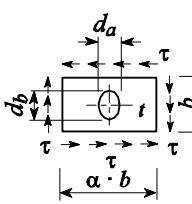
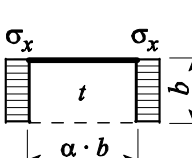
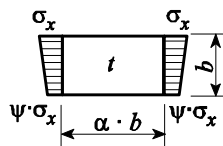
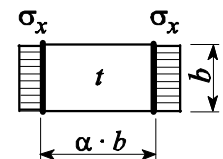
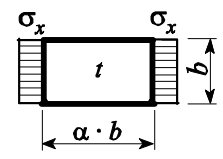
### 3 Buckling criteria of elementary plate panels

#### 3.1 Plates

##### 3.1.1 General

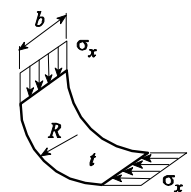
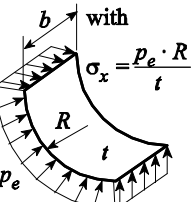
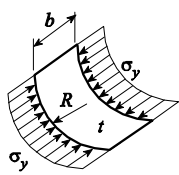
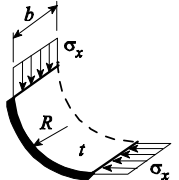
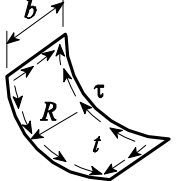
The net thickness of the elementary plate panel is to comply with the following:

$$t \geq b/100$$

The verification of an elementary plate panel in a transverse section analysis is to be carried out according to [3.1.2]. It is to be performed for the two different following combinations of stresses:

- stress combination 1: 100% of the normal stress as defined in [2.1.2] and 70% of the shear stress as defined in [2.1.3]
- stress combination 2: 70% of the normal stress as defined in [2.1.2] and 100% of the shear stress as defined

in [2.1.3].

The verification of elementary plate panel in a FEM analysis is to be carried out according to [3.2].

### 3.1.2 Verification of elementary plate panel in a transverse section analysis

Each elementary plate panel is to comply with the following criteria, taking into account the loads defined in [2.1]:

— longitudinally framed plating

$$\left( \frac{|\sigma_x|S}{\kappa_x R_{eH}} \right)^{e1} + \left( \frac{|\tau|S\sqrt{3}}{\kappa_\tau R_{eH}} \right)^{e3} \leq 1.0 \quad \text{for stress combination 1 with } \sigma_x = \sigma_n \text{ and } \tau = 0.7\tau_{SF}$$

$$\left( \frac{|\sigma_x|S}{\kappa_x R_{eH}} \right)^{e1} + \left( \frac{|\tau|S\sqrt{3}}{\kappa_\tau R_{eH}} \right)^{e3} \leq 1.0 \quad \text{for stress combination 2 with } \sigma_x = 0.7\sigma_n \text{ and } \tau = \tau_{SF}$$

— transversely framed plating

$$\left( \frac{|\sigma_y|S}{\kappa_y R_{eH}} \right)^{e2} + \left( \frac{|\tau|S\sqrt{3}}{\kappa_\tau R_{eH}} \right)^{e3} \leq 1.0 \quad \text{for stress combination 1 with } \sigma_y = \sigma_n \text{ and } \tau = 0.7\tau_{SF}$$

$$\left( \frac{|\sigma_y|S}{\kappa_y R_{eH}} \right)^{e2} + \left( \frac{|\tau|S\sqrt{3}}{\kappa_\tau R_{eH}} \right)^{e3} \leq 1.0 \quad \text{for stress combination 2 with } \sigma_y = 0.7\sigma_n \text{ and } \tau = \tau_{SF}$$

Each term of the above conditions must be less than 1.0.

The reduction factors  $\kappa_x$  and  $\kappa_y$  are given in Table 2 and/or Table 3.

The coefficients  $e1$ ,  $e2$  and  $e3$  are defined in Table 4.

For the determination of  $e3$ ,  $\kappa_y$  is to be taken equal to 1 in case of longitudinally framed plating and  $\kappa_x$  is to be taken equal to 1 in case of transversely framed plating.

## 3.2 Verification of elementary plate panel within FEM analysis

### 3.2.1 General

The buckling check of the elementary plate panel is to be performed under the loads defined in [3.2.2], according to the requirements of [3].

The determination of the buckling and reduction factors is made for each relevant case of Table 2 according to the stresses calculated in [3.2.2] loading the considered elementary plate panel.

### 3.2.2 Stresses

For the buckling check, the buckling stresses are to be determined according to Table 2 and Table 3 including their stress ratio  $\Psi$  for the loading conditions required in Ch 4, Sec 7 and according to the requirements of Ch 7.

### 3.2.3 Poisson effect

Stresses derived with superimposed or direct method have to be reduced for buckling assessment because of the Poisson effect, which is taken into consideration in both analysis methods. The correction has to be carried out after summation of stresses due to local and global loads.

Both stresses  $\sigma_x^*$  and  $\sigma_y^*$  are to be compressive stresses, in order to apply the stress reduction according to the following formulae:

$$\sigma_x = (\sigma_x^* - 0.3\sigma_y^*)/0.91$$

$$\sigma_y = (\sigma_y^* - 0.3\sigma_x^*)/0.91$$

where:

$\sigma_x^*$ ,  $\sigma_y^*$ : Stresses containing the Poisson effect

Where compressive stress fulfils the condition  $\sigma_y^* < 0.3\sigma_x^*$ , then  $\sigma_y = 0$  and  $\sigma_x = \sigma_x^*$

Where compressive stress fulfils the condition  $\sigma_x^* < 0.3\sigma_y^*$ , then  $\sigma_x = 0$  and  $\sigma_y = \sigma_y^*$

### 3.2.4 Checking Criteria

Each elementary plate panel is to comply with the following criteria, taking into account the loads defined in [2.1] :

$$\left(\frac{|\sigma_x|S}{\kappa_x R_{eH}}\right)^{e1} + \left(\frac{|\sigma_y|S}{\kappa_y R_{eH}}\right)^{e2} - B \left(\frac{\sigma_x \sigma_y S^2}{R_{eH}^2}\right) + \left(\frac{|\tau|S\sqrt{3}}{\kappa_\tau R_{eH}}\right)^{e3} \leq 1.0$$

In addition, each compressive stress  $\sigma_x$  and  $\sigma_y$ , and the shear stress  $\tau$  are to comply with the following formulae:

$$\left(\frac{\sigma_x S}{\kappa_x R_{eH}}\right)^{e1} \leq 1.0$$

$$\left(\frac{\sigma_y S}{\kappa_y R_{eH}}\right)^{e2} \leq 1.0$$

$$\left(\frac{|\tau|S\sqrt{3}}{\kappa_\tau R_{eH}}\right)^{e3} \leq 1.0$$

The reduction factors  $\kappa_x$ ,  $\kappa_y$  and  $\kappa_\tau$  are given in Table 2 and/or Table 3.

— where  $\sigma_x \leq 0$  (tensile stress),  $\kappa_x = 1.0$ .

— where  $\sigma_y \leq 0$  (tensile stress),  $\kappa_y = 1.0$ .

The coefficients  $e1$ ,  $e2$  and  $e3$  as well as the factor  $B$  are defined in Table 4.

Exponents $e1 - e3$ and factor $B$	Plate panel	
	plane	curved
$e1$	$1 + \kappa_x^4$	1.25
$e2$	$1 + \kappa_y^4$	1.25
$e3$	$1 + \kappa_x \kappa_y \kappa_\tau^2$	2.0
$B$ $\sigma_x$ and $\sigma_y$ positive (compressive stress)	$(\kappa_x \kappa_y)^5$	0
$B$ $\sigma_x$ or $\sigma_y$ negative (tensile stress)	1	-

## 3.3 Webs and flanges

### 3.3.1

For non-stiffened webs and flanges of sections and girders proof of sufficient buckling strength as for elementary plate panels is to be provided according to [3.1].

## 4 Buckling criteria of partial and total panels

### 4.1 Longitudinal and transverse stiffeners

#### 4.1.1

In a hull transverse section analysis, the longitudinal and transverse ordinary stiffeners of partial and total plate panels are to comply with the requirements of [4.2] and [4.3].

### 4.2 Ultimate strength in lateral buckling mode

#### 4.2.1 Checking criteria

The longitudinal and transverse ordinary stiffeners are to comply with the following criteria:

$$\frac{\sigma_a + \sigma_b}{R_{eH}} S \leq 1$$

$\sigma_a$  = Uniformly distributed compressive stress, in N/mm<sup>2</sup> in the direction of the stiffener axis.

$\sigma_a = \sigma_n$  for longitudinal stiffeners

$\sigma_a = 0$  for transverse stiffeners

$\sigma_b$  = Bending stress, in N/mm<sup>2</sup>, in the stiffener.

$\sigma_b$  calculated as in [4.2.2] with  $\sigma_x = \sigma_n$  and  $\tau = \tau_{SF}$

#### 4.2.2 Evaluation of the bending stress $\sigma_b$

The bending stress  $\sigma_b$ , in N/mm<sup>2</sup>, in the stiffeners is equal to:

$$\sigma_b = \frac{M_0 + M_1}{W_{st} 10^3}$$

with:

$M_0$  = Bending moment, in N.mm, due to the deformation  $w$  of stiffener, taken equal to:

$$M_0 = F_{Ki} \frac{p_z w}{c_f - p_z}$$

with  $(c_f - p_z) > 0$

$M_1$  = Bending moment, in N.mm, due to the lateral load  $p$ , taken equal to:

$$M_1 = \frac{p b a^2}{24 \cdot 10^3} \quad \text{for longitudinal stiffeners}$$

$$M_1 = \frac{p a (n \cdot b)^2}{8 c_S 10^3} \quad \text{for transverse stiffeners, with } n \text{ equal to 1 for ordinary transverse stiffeners.}$$

$W_{st}$  = Net section modulus of stiffener (longitudinal or transverse), in cm<sup>3</sup>, including effective width of plating according to [5], taken equal to:

if a lateral pressure is applied on the stiffener:

$W_{st}$  is the net section modulus calculated at flange if the lateral pressure is applied on the same side as the stiffener.

$W_{st}$  is the net section modulus calculated at attached plate if the lateral pressure is applied on the side opposite to the stiffener.

if no lateral pressure is applied on the stiffener:

$W_{st}$  is the minimum net section modulus among those calculated at flange and attached plate

$c_S$  = Factor accounting for the boundary conditions of the transverse stiffener

$c_S = 1.0$  for simply supported stiffeners

$c_S = 2.0$  for partially constraint stiffeners

$p$  = Lateral load in kN/m<sup>2</sup>, as defined in Ch 4, Sec 5 and Ch 4, Sec 6 calculated at the load point as defined in Ch 6, Sec 2, [1.4.2]

$F_{Ki}$  = Ideal buckling force, in N, of the stiffener, taken equal to:



$$F_{K_{lx}} = \frac{\pi^2}{a^2} EI_x 10^4 \quad \text{for longitudinal stiffeners}$$

$$F_{K_{ly}} = \frac{\pi^2}{(nb)^2} EI_y 10^4 \quad \text{for transverse stiffeners}$$

$I_x, I_y$  = Net moments of inertia, in  $\text{cm}^4$ , of the longitudinal or transverse stiffener including effective width of attached plating according to [5].  $I_x$  and  $I_y$  are to comply with the following criteria:

$$I_x \geq \frac{bt^3}{12 \cdot 10^4}$$

$$I_y \geq \frac{at^3}{12 \cdot 10^4}$$

$p_z$  = Nominal lateral load, in  $\text{N/mm}^2$ , of the stiffener due to  $\sigma_x$ ,  $\sigma_y$  and  $\tau$

$$p_{zx} = \frac{t_a}{b} \left( \sigma_{xl} \left( \frac{\pi b}{a} \right)^2 + 2c_y \sigma_y + \tau_1 \sqrt{2} \right) \quad \text{for longitudinal stiffeners}$$

$$p_{zy} = \frac{t_a}{a} \left( 2c_x \sigma_{xl} + \sigma_y \left( \frac{\pi a}{nb} \right)^2 \left( 1 + \frac{A_y}{at_a} \right) + \tau_1 \sqrt{2} \right) \quad \text{for transverse stiffeners}$$

$$\sigma_{xl} = \sigma_x \left( 1 + \frac{A_x}{b \cdot t_a} \right)$$

$t_a$  = Net thickness offered of attached plate, in mm

$C_x, C_y$  = Factor taking into account the stresses vertical to the stiffener's axis and distributed variable along the stiffener's length taken equal to:

$$0.5(1 + \psi) \quad \text{for} \quad 0 \leq \psi \leq 1$$

$$\frac{0.5}{1 - \psi} \quad \text{for} \quad \psi < 0$$

$A_x, A_y$  = Net sectional area, in  $\text{mm}^2$ , of the longitudinal or transverse stiffener respectively without attached plating

$$\tau_1 = \left[ \tau - t \sqrt{R_{eH} E \left( \frac{m_1}{a^2} + \frac{m_2}{b^2} \right)} \right] \geq 0$$

$m_1, m_2$  = Coefficients taken equal to:

$$\frac{a}{b} \geq 2,0 \quad : \quad m_1 = 1.47 \quad m_2 = 0.49 \quad \text{for longitudinal stiffeners}$$

$$\frac{a}{b} < 2,0 \quad : \quad m_1 = 1.96 \quad m_2 = 0.37$$

$$\frac{a}{n \cdot b} \geq 0,5 \quad : \quad m_1 = 0.37 \quad m_2 = \frac{1.96}{n^2} \quad \text{for transverse stiffeners}$$

$$\frac{a}{n \cdot b} < 0,5 \quad : \quad m_1 = 0.49 \quad m_2 = \frac{1.47}{n^2}$$

$$w = w_0 + w_1$$

$w_0$  = Assumed imperfection, in mm, taken equal to:

$$w_0 = \min\left(\frac{a}{250}, \frac{b}{250}, 10\right) \quad \text{for longitudinal stiffeners}$$

$$w_0 = \min\left(\frac{a}{250}, \frac{n \cdot b}{250}, 10\right) \quad \text{for transverse stiffeners}$$

For stiffeners sniped at both ends  $w_0$  must not be taken less than the distance from the midpoint of attached plating to the neutral axis of the stiffener calculated with the effective width of its attached plating.

$w_1$  = Deformation of stiffener, in mm, at midpoint of stiffener span due to lateral load  $p$ . In case of uniformly distributed load the following values for  $w_1$  may be used:

$$w_1 = \frac{pba^4}{384 \cdot 10^7 EI_x} \quad \text{for longitudinal stiffeners}$$

$$w_1 = \frac{5ap(nb)^4}{384 \cdot 10^7 EI_y c_s^2} \quad \text{for transverse stiffeners}$$

$c_f$  = Elastic support provided by the stiffener, in  $\text{N/mm}^2$ , taken equal to:  
for longitudinal stiffeners

$$c_f = F_{Kix} \frac{\pi^2}{a^2} (1 + c_{px})$$

$$c_{px} = \frac{1}{1 + \frac{0.91 \left( \frac{12 \cdot 10^4 I_x - 1}{t^3 b} \right)}{c_{xa}}}$$

$c_{xa}$  = Coefficient taken equal to :

$$c_{xa} = \left[ \frac{a}{2b} + \frac{2b}{a} \right]^2 \quad \text{for } a \geq 2b$$

$$c_{xa} = \left[ 1 + \left( \frac{a}{2b} \right)^2 \right]^2 \quad \text{for } a < 2b$$

for transverse stiffeners:

$$c_f = c_s F_{Kiy} \frac{\pi^2}{(n \cdot b)^2} (1 + c_{py})$$

$$c_{py} = \frac{1}{1 + \frac{0.91 \left( \frac{12 \cdot 10^4 I_y - 1}{t^3 a} \right)}{c_{ya}}}$$

$c_{ya}$  = Coefficient taken equal to :

$$c_{ya} = \left[ \frac{nb}{2a} + \frac{2a}{nb} \right]^2 \quad \text{for } nb \geq 2a$$

$$c_{ya} = \left[ 1 + \left( \frac{nb}{2a} \right)^2 \right]^2 \quad \text{for } nb < 2a$$

#### 4.2.3 Equivalent criteria for longitudinal and transverse ordinary stiffeners not subjected to lateral pressure

Longitudinal and transverse ordinary stiffeners not subjected to lateral pressure are considered as complying with the requirement of [4.2.1] if their net moments of inertia  $I_x$  and  $I_y$ , in  $\text{cm}^4$ , are not less than the value obtained by the following formula:

— For longitudinal stiffener :

$$I_x = \frac{p_{zx} a^2}{\pi^2 10^4} \left( \frac{w_{0x} h_w}{\frac{R_{eH}}{S} - \sigma_x} + \frac{a^2}{\pi^2 E} \right)$$

— For transverse stiffener :

$$I_y = \frac{p_{zy}(nb)^2}{\pi^2 10^4} \left( \frac{w_{0y} h_w}{\frac{R_{eH}}{S} - \sigma_y} + \frac{(nb)^2}{\pi^2 E} \right)$$

### 4.3 Torsional buckling

#### 4.3.1 Longitudinal stiffeners

The longitudinal ordinary stiffeners are to comply with the following criteria:

$$\frac{\sigma_x S}{\kappa_T R_{eH}} \leq 1.0$$

$\kappa_T$  = Coefficient taken equal to:

$$\kappa_T = 1.0 \text{ for } \lambda_T \leq 0.2$$

$$\kappa_T = \frac{1}{\Phi + \sqrt{\Phi^2 - \lambda_T^2}} \text{ for } \lambda_T > 0.2$$

$$\Phi = 0.5(1 + 0.21(\lambda_T - 0.2) + \lambda_T^2)$$

$\lambda_T$  = Reference degree of slenderness taken equal to:

$$\lambda_T = \sqrt{\frac{R_{eH}}{\sigma_{\kappa iT}}}$$

$$\sigma_{\kappa iT} = \frac{E}{I_P} \left( \frac{\pi^2 I_{\omega} 10^2}{a^2} \varepsilon + 0.385 I_T \right), \text{ in N/mm}^2$$

$I_P$  = Net polar moment of inertia of the stiffener, in cm<sup>4</sup>, defined in Table 5, and related to the point C as shown in Fig 2

$I_T$  = Net St. Venant's moment of inertia of the stiffener, in cm<sup>4</sup>, defined in Table 5

$I_{\omega}$  = Net sectorial moment of inertia of the stiffener, in cm<sup>6</sup>, defined in Table 5, related to the point C as shown in Fig 2

$\varepsilon$  = Degree of fixation taken equal to:

$$\varepsilon = 1 + 10^{-3} \sqrt{\frac{a^4}{\frac{3}{4} \pi^4 I_w \left( \frac{b}{t^3} + \frac{4h_w}{3t_w^3} \right)}}$$

$A_w$  = Net web area equal to:  $A_w = h_w t_w$

$A_f$  = Net flange area equal to:  $A_f = b_f t_f$

$e_f = h_w + \frac{t_f}{2}$ , in mm

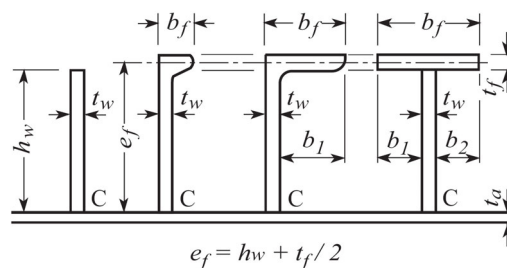

Fig. 2  
Dimensions of stiffeners

<b>Table 5 Moments of inertia</b>			
<i>Profile</i>	$I_P$	$I_T$	$I_w$
Flat bar	$\frac{h_w^3 t_w}{3 \cdot 10^4}$	$\frac{h_w t_w^3}{3 \cdot 10^4} \left( 1 - 0.63 \frac{t_w}{h_w} \right)$	$\frac{h_w^3 t_w^3}{36 \cdot 10^6}$
Sections with bulb or flange	$\left( \frac{A_w h_w^2}{3} + A_f e_f^2 \right) 10^{-4}$	$\frac{h_w t_w^3}{3 \cdot 10^4} \left( 1 - 0.63 \frac{t_w}{h_w} \right) + \frac{b_f t_f^3}{3 \cdot 10^4} \left( 1 - 0.63 \frac{t_f}{b_f} \right)$	for bulb and angle sections: $\frac{A_f e_f^2 b_f^2}{12 \cdot 10^6} \left( \frac{A_f + 2.6 A_w}{A_f + A_w} \right)$ for tee-sections: $\frac{b_f^3 t_f e_f^2}{12 \cdot 10^6}$

### 4.3.2 Transverse stiffeners

Transverse stiffeners loaded by axial compressive stresses and which are not supported by longitudinal stiffeners are to comply with the requirements of [4.3.1] analogously.

## 5 Effective width of attached plating

### 5.1 Ordinary stiffeners

#### 5.1.1

The effective width of attached plating of ordinary stiffeners is determined by the following formulae (see also Fig 1):

— for longitudinal stiffeners:  $b_m = \min(\kappa_x b, \kappa_s s)$

— for transverse stiffeners:  $a_m = \min(\kappa_y a, \kappa_s s)$

where:

$$\kappa_s = 0.0035 \left( \frac{\ell_{eff}}{s} \right)^3 - 0.0673 \left( \frac{\ell_{eff}}{s} \right)^2 + 0.4422 \left( \frac{\ell_{eff}}{s} \right) - 0.0056$$

to be taken not greater than 1.0

s = Spacing of the stiffener, in mm

$\ell_{eff}$  = Value taken as follows:

— for longitudinal stiffeners:

$\ell_{eff} = a$  if simply supported at both ends

$\ell_{eff} = 0.6 a$  if fixed at both ends

— for transverse stiffeners:

$\ell_{eff} = b$  if simply supported at both ends

$\ell_{eff} = 0.6 b$  if fixed at both ends

### 5.2 Primary supporting members

The effective width  $e'_m$  of stiffened flange plates of primary supporting members may be determined as described in a) and b), with the notations:

$e$  = Width of plating supported, in mm, measured from centre to centre of the adjacent unsupported fields

$e_m$  = Effective width, in mm, of attached plating of primary supporting member according to Table 6 considering the type of loading (special calculations may be required for determining the effective width of one-sided or non-symmetrical flanges).

$e_{m1}$  is to be applied where primary supporting members are loaded by uniformly distributed loads or else by not less than 6 equally spaced single loads.

$e_{m2}$  is to be applied where primary supporting members are loaded by 3 or less single loads.

a) Stiffening parallel to web of the primary supporting member (see Fig 3)

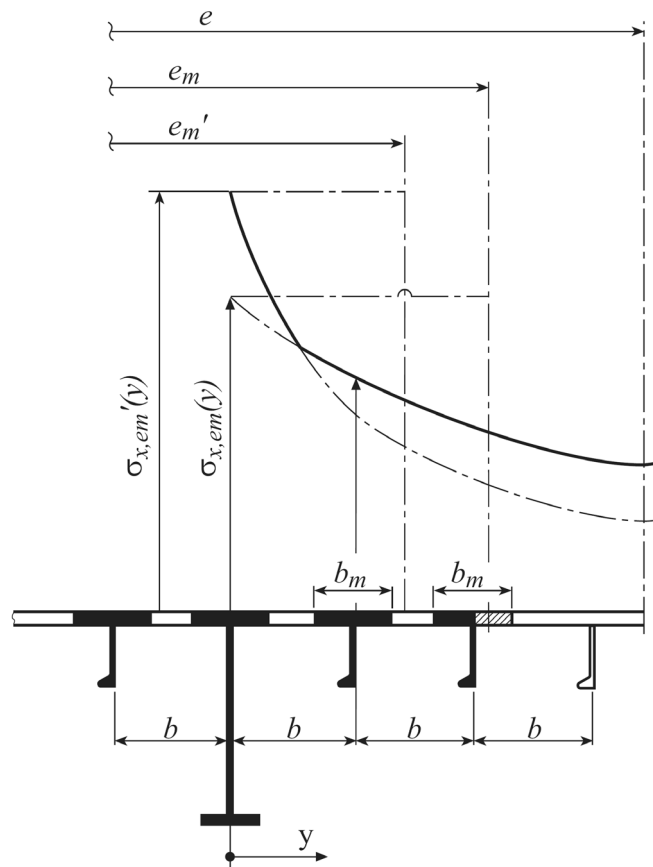

**Fig. 3**  
Stiffening parallel to web

$$b < e_m$$

$$e'_m = n \cdot b_m$$

$n$  = Integral number of the stiffener spacing  $b$  inside the effective width  $e_m$ , taken equal to:

$$n = \text{int} \left( \frac{e_m}{b} \right)$$

b) Stiffening perpendicular to web of the primary supporting member (see Fig 4)

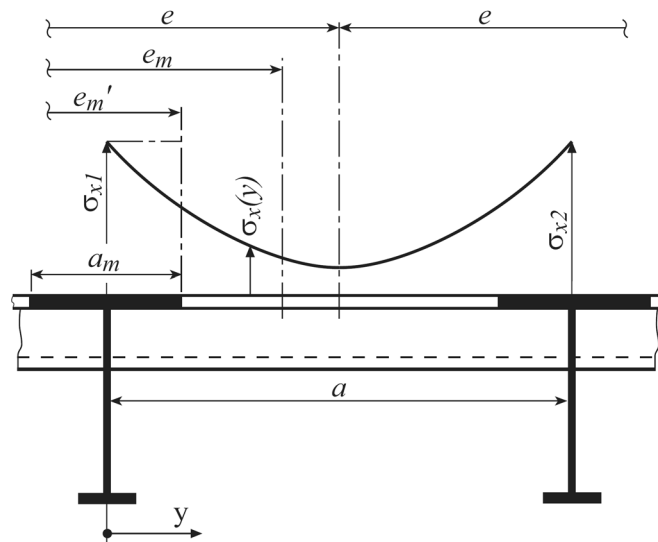

**Fig. 4**  
Stiffening perpendicular to web

$$a \geq e_m$$

$$e_m' = na_m < e_m$$

$$n = 2.7 \frac{e_m}{a}, \text{ to be taken not greater than } 1.0$$

For  $b \geq e_m$  or  $a < e_m$  respectively,  $b$  and  $a$  must be exchanged.

$l/e$	0	1	2	3	4	5	6	7	$\geq 8$
$e_{m1}/e$	0	0.36	0.64	0.82	0.91	0.96	0.98	1.00	1.00
$e_{m2}/e$	0	0.20	0.37	0.52	0.65	0.75	0.84	0.89	0.90

Intermediate values may be obtained by direct interpolation.

$l$  = Length between zero-points of bending moment curve, i.e. unsupported span in case of simply supported girders and 0.6 times the unsupported span in case of constraint of both ends of girder.

## 6 Transverse vertically corrugated watertight bulkhead in flooded conditions

### 6.1 General

#### 6.1.1 Shear buckling check of the bulkhead corrugation webs

The shear stress  $\tau$ , calculated according to Ch 6, Sec 2, [3.6.1], is to comply with the following formula:

$$\tau \leq \tau_C$$

where:

$\tau_C$  = Critical shear buckling stress to be obtained, in N/mm<sup>2</sup>, from the following formulae:

$$\tau_c = \tau_E \quad \text{for } \tau_E \leq \frac{R_{eH}}{2\sqrt{3}}$$

$$\tau_c = \frac{R_{eH}}{\sqrt{3}} \left( 1 - \frac{R_{eH}}{4\sqrt{3} \tau_E} \right) \quad \text{for } \tau_E > \frac{R_{eH}}{2\sqrt{3}}$$

$\tau_E$  = Euler shear buckling stress to be obtained, in N/mm<sup>2</sup>, from the following formula:

$$\tau_E = 0.9k_t E \left( \frac{t_w}{10^3 c} \right)^2$$

- $k_t$  = Coefficient, to be taken equal to 6.34  
 $t_w$  = Net thickness, in mm, of the corrugation webs  
 $c$  = Width, in m of the corrugation webs (see Ch 3, Sec 6, Fig 28).

## SECTION 4 PRIMARY SUPPORTING MEMBERS

### Symbols

For symbols not defined in this Section, refer to Ch 1, Sec 4.

$L_2$	= Rule length $L$ , but to be taken not greater than 300 m
$I_Y$	= Net moment of inertia, in $m^4$ , of the hull transverse section about its horizontal neutral axis, to be calculated according to Ch 5, Sec 1, [1.5], on gross offered thickness reduced by $0.5t_C$ for all structural members
$I_Z$	= Net moment of inertia, in $m^4$ , of the hull transverse section about its vertical neutral axis, to be calculated according to Ch 5, Sec 1, [1.5], on gross offered thickness reduced by $0.5t_C$ for all structural members
$N$	= $Z$ co-ordinate with respect to the reference co-ordinate system defined in Ch 1, Sec 4, [4], in m, of the centre of gravity of the hull net transverse section defined in Ch 5, Sec 1, [1.2], considering gross offered thickness reduced by $0.5t_C$ for all structural members
$p_S, p_W$	= Still water and wave pressure, in $kN/m^2$ , in intact conditions, defined in [2.1.2]
$\sigma_X$	= Normal stress, in $N/mm^2$ , defined in [2.1.5]
$s$	= Spacing, in m, of primary supporting members
$\ell$	= Span, in m, of primary supporting members, measured between the supporting members, see Ch 3, Sec 6, [5.3]
$h_w$	= Web height, in mm
$t_w$	= Net web thickness, in mm
$b_f$	= Face plate width, in mm
$t_f$	= Net face plate thickness, in mm
$b_p$	= Width, in m, of the plating attached to the member, for the yielding check, defined in Ch 3, Sec 6, [4.3]
$w$	= Net section modulus, in $cm^3$ , of the member, with an attached plating of width $b_p$ , to be calculated as specified in Ch 3, Sec 6, [4.4]
$A_{sh}$	= Net shear sectional area, in $cm^2$ , of the member, to be calculated as specified in Ch 3, Sec 6, [5.5]
$m$	= Coefficient taken equal to 10
$\tau_a$	= Allowable shear stress, in $N/mm^2$ , taken equal to: $\tau_a = 0.4 R_Y$
$k$	= Material factor, as defined in Ch 1, Sec 4, [2.2.1]
$x, y, z$	= $X, Y$ and $Z$ co-ordinates, in m, of the evaluation point with respect to the reference co-ordinate system defined in Ch 1, Sec 4.

## 1 General

### 1.1 Application

#### 1.1.1

The requirements of this Section apply to the strength check of pillars and primary supporting members, subjected to lateral pressure and/or hull girder normal stresses for such members contributing to the hull girder longitudinal strength.

The yielding check is also to be carried out for such members subjected to specific loads, such as concentrated loads.

### 1.2 Primary supporting members for ships less than 150 m in length $L$

#### 1.2.1

For primary supporting members for ships having a length  $L$  less than 150 m, the strength check of such members is to be carried out according to the provisions specified in [2] and [4].

#### 1.2.2

Notwithstanding the above, the strength check of such members may be carried out by a direct strength assessment deemed as appropriate by the Society.



## 1.3 Primary supporting members for ships of 150 m or more in length $L$

### 1.3.1

For primary supporting members for ships having a length  $L$  of 150 m or more, the direct strength analysis is to be carried out according to the provisions specified in Ch 7, and the requirements in [4] are also to be complied with. In addition, the primary supporting members for **BC-A** and **BC-B** ships are to comply with the requirements in [3].

## 1.4 Net scantlings

### 1.4.1

As specified in Ch 3, Sec 2, all scantlings referred to in this Section are net, i.e. they do not include any corrosion addition.

The gross scantlings are obtained as specified in Ch 3, Sec 2, [3].

## 1.5 Minimum net thicknesses of webs of primary supporting members

### 1.5.1

The net thickness of the web of primary supporting members, in mm, is to be not less than  $0.6\sqrt{L_2}$ .

## 2 Scantling of primary supporting members for ships of less than 150 m in length $L$

### 2.1 Load model

#### 2.1.1 General

The still water and wave lateral loads induced by the sea and the various types of cargoes and ballast in intact conditions are to be considered, depending on the location of the primary supporting members under consideration and the type of the compartments adjacent to it.

The wave lateral loads and hull girder loads are to be calculated, for the probability level of  $10^{-8}$ , in the mutually exclusive load cases H1, H2, F1, F2, R1, R2, P1 and P2, as defined in Ch 4, Sec 4.

#### 2.1.2 Lateral pressure in intact conditions

The lateral pressure in intact conditions is constituted by still water pressure and wave pressure.

Still water pressure ( $p_S$ ) includes:

- the hydrostatic pressure, defined in Ch 4, Sec 5, [1]
- the still water internal pressure, defined in Ch 4, Sec 6 for the various types of cargoes and for ballast.

Wave pressure ( $p_W$ ) includes for each load case H1, H2, F1, F2, R1, R2, P1 and P2:

- the hydrodynamic pressure, defined in Ch 4, Sec 5, [1]
- the inertial pressure, defined in Ch 4, Sec 6 for the various types of cargoes and for ballast.

#### 2.1.3 Elements of the outer shell

The still water and wave lateral pressures are to be calculated considering separately:

- the still water and wave external sea pressures
- the still water and wave internal pressure, considering the compartment adjacent to the outer shell as being loaded

If the compartment adjacent to the outer shell is not intended to carry liquids, only the external sea pressures are to be considered.

#### 2.1.4 Elements other than those of the outer shell

The still water and wave lateral pressures to be considered as acting on an element which separates two adjacent compartments are those obtained considering the two compartments individually loaded.

#### 2.1.5 Normal stresses

The normal stress to be considered for the strength check of primary supporting members contributing to the hull girder longitudinal strength is the maximum value of  $\sigma_X$  between sagging and hogging conditions, when

applicable, obtained , in N/mm<sup>2</sup>, from the following formula:

$$\sigma_x = \left[ C_{SW} \left| \frac{M_{SW}}{I_y} \right| (z - N) + C_{WV} \left| \frac{M_{WV}}{I_y} \right| (z - N) - C_{WH} \left| \frac{M_{WH}}{I_z} \right| y \right] 10^{-3}$$

where:

- $M_{SW}$  = Permissible still water bending moments, in kN.m, in hogging or sagging as the case may be  
 $M_{WV}$  = Vertical wave bending moment, in kN.m, in hogging or sagging as the case may be, as defined in Ch 4, Sec 3  
 $M_{WH}$  = Horizontal wave bending moment, in kN.m, as defined in Ch 4, Sec 3  
 $C_{SW}$  = Combination factor for each load case H1, H2, F1, F2, R1, R2, P1 and P2 and defined in the Table 1  
 $C_{WV}, C_{WH}$  = Combination factors defined in Ch 4, Sec 4, [2.2] for each load case H1, H2, F1, F2, R1, R2, P1 and P2 and given in the Table 1.

Table 1 Combination factors $C_{SW}$ , $C_{WV}$ and $C_{WH}$						
LC	Hogging			Sagging		
	$C_{SW}$	$C_{WV}$	$C_{WH}$	$C_{SW}$	$C_{WV}$	$C_{WH}$
H1	Not Applicable			-1	-1	0
H2	1	1	0	Not Applicable		
F1	Not Applicable			-1	-1	0
F2	1	1	0	Not Applicable		
R1	1	0	$1.2 - \frac{T_{LC}}{T_S}$	-1	0	$1.2 - \frac{T_{LC}}{T_S}$
R2	1	0	$\frac{T_{LC}}{T_S} - 1.2$	-1	0	$\frac{T_{LC}}{T_S} - 1.2$
P1	1	$0.4 - \frac{T_{LC}}{T_S}$	0	-1	$0.4 - \frac{T_{LC}}{T_S}$	0
P2	1	$\frac{T_{LC}}{T_S} - 0.4$	0	-1	$\frac{T_{LC}}{T_S} - 0.4$	0

## 2.2 Center Girders and Side Girders

### 2.2.1 Net web thickness

The net thickness of girders in double bottom structure, in mm, is not to be less than the greatest of either of the value  $t_1$  to  $t_3$  specified in the followings according to each location:

$$t_1 = C_1 \frac{pS|x - x_c|}{(d_0 - d_1)\tau_a} \left\{ 1 - 4 \left( \frac{y}{B_{DB}} \right)^2 \right\}$$

where  $|x - x_c|$  is less than  $0.25\ell_{DB}$ ,  $|x - x_c|$  is to be taken as  $0.25\ell_{DB}$

$$t_2 = 1.75 \cdot \sqrt[3]{\frac{H^2 a^2 \tau_a}{C_1}} t_1$$

$$t_3 = \frac{C_1'' a}{\sqrt{k}}$$

where:

$P$  = Differential pressure given by the following formula in kN/m<sup>2</sup>:

$$P = |(p_{S,IB} + p_{W,IB}) - (p_{S,BM} + p_{W,BM})|$$

- $P_{S,IB}$  = Cargo or ballast pressure of inner bottom plating in still water, in kN/m<sup>2</sup>, as calculated at the center of the double bottom structure under consideration, according to Ch 4, Sec 6
- $P_{W,IB}$  = Cargo or ballast pressure of inner bottom plating due to inertia, in kN/m<sup>2</sup>, as calculated at the center of the double bottom structure under consideration, according to Ch 4, Sec 6
- $P_{S,BM}$  = External sea and ballast pressure of bottom plating in still water, in kN/m<sup>2</sup>, as calculated at the center of the double bottom structure under consideration, according to Ch 4, Sec 5 and Ch 4, Sec 6
- $P_{W,BM}$  = External sea and ballast pressure of bottom plating due to inertia, in kN/m<sup>2</sup>, as calculated at the center of the double bottom structure under consideration, according to Ch 4, Sec 5 and Ch 4, Sec 6
- $S$  = Distance between the centers of the two spaces adjacent to the center or side girder under consideration, in m
- $d_0$  = Depth of the center or side girder under consideration, in m
- $d_1$  = Depth of the opening, if any, at the point under consideration, in m
- $\ell_{DB}$  = Length of the double bottom, in m. Where stools are provided at transverse bulkheads,  $\ell_{BD}$  may be taken as the distance between the toes.
- $x_c$  =  $X$  co-ordinate, in m, of the center of double bottom structure under consideration with respect to the reference co-ordinate system defined in Ch 1, Sec 4
- $B_{DB}$  = Distance between the toes of hopper tanks at the midship part, in m, see Fig 3
- $C_1$  = Coefficient obtained from Table 2 depending on  $B_{DB}/\ell_{DB}$ . For intermediate values of  $B_{DB}/\ell_{DB}$ ,  $C_1$  is to be obtained by linear interpolation
- $a$  = Depth of girders at the point under consideration, in m. However, where horizontal stiffeners are fitted on the girder,  $a$  is the distance from the horizontal stiffener under consideration to the bottom shell plating or inner bottom plating, or the distance between the horizontal stiffeners under consideration
- $S_1$  = Spacing, in m, of vertical ordinary stiffeners or floors
- $C_1'$  = Coefficient obtained from Table 3 depending on  $S_1/a$ . For intermediate values of  $S_1/a$ ,  $C_1'$  is to be determined by linear interpolation
- $H$  = Value obtained from the following formulae:  
— where the girder is provided with an unreinforced opening:  
$$H = 1 + 0.5 \frac{\phi}{\alpha}$$
  
— In other cases:  $H = 1.0$
- $\phi$  = Major diameter of the openings, in m
- $\alpha$  = The greater of  $a$  or  $S_1$ , in m.
- $C_1''$  = Coefficient obtained from Table 4 depending on  $S_1/a$ . For intermediate values of  $S_1/a$ ,  $C_1''$  is to be obtained by linear interpolation.

Table 2 Coefficient $C_1$							
$B_{DB}/\ell_{DB}$	0.4 and under	0.6	0.8	1.0	1.2	1.4	1.6 and over
$C_1$	0.5	0.71	0.83	0.88	0.95	0.98	1.00

Table 3 Coefficient $C_1'$										
$\frac{S_1}{a}$	0.3 and under	0.4	0.5	0.6	0.7	0.8	0.9	1.0	1.2	1.4 and over
$C_1'$	64	38	25	19	15	12	10	9	8	7

$\frac{S_1}{a}$		0.3 and under	0.4	0.5	0.6	0.7	0.8	0.9	1.0	1.2	1.4	1.6 and over
$C_1''$	Centre girder	4.4	5.4	6.3	7.1	7.7	8.2	8.6	8.9	9.3	9.6	9.7
	Side girder	3.6	4.4	5.1	5.8	6.3	6.7	7.0	7.3	7.6	7.9	8.0

## 2.3 Floors

### 2.3.1 Net web thickness

The net thickness of floors in double bottom structure, in mm, is not to be less than the greatest of values  $t_1$  to  $t_3$  specified in the followings according to each location:

$$t_1 = C_2 \frac{pSB_{DB}}{(d_0 - d_1)\tau_a} \left( \frac{2|y|}{B'_{DB}} \right) \left\{ 1 - 2 \left( \frac{x - x_c}{l_{DB}} \right)^2 \right\}$$

where  $|x - x_c|$  is less than  $0.25\ell_{DB}$ ,  $|x - x_c|$  is to be taken as  $0.25\ell_{DB}$  and where  $|y|$  is less than  $B'_{DB}/4$ ,  $|y|$  is to be taken as  $B'_{DB}/4$

$$t_2 = 1.75 \cdot 3 \sqrt{\frac{H^2 a^2 \tau_a}{C_2'} t_1}$$

$$t_3 = \frac{8.5S_2}{\sqrt{k}}$$

where:

- $S$  = Spacing of solid floors, in m
- $d_0$  = Depth of the solid floor at the point under consideration in m
- $d_1$  = Depth of the opening, if any, at the point under consideration in m
- $B'_{DB}$  = Distance between toes of hopper tanks at the position of the solid floor under consideration, in m
- $C_2$  = Coefficient obtained from Table 5 depending on  $B_{DB}/\ell_{DB}$ . For intermediate values of  $B_{DB}/\ell_{DB}$ ,  $C_2$  is to be obtained by linear interpolation
- $p, B_{DB}, x_c, \ell_{DB}$  = As defined in [2.2.1]
- $a$  = Depth of the solid floor at the point under consideration, in m. However, where horizontal stiffeners are fitted on the floor,  $a$  is the distance from the horizontal stiffener under consideration to the bottom shell plating or the inner bottom plating or the distance between the horizontal stiffeners under consideration
- $S_1$  = Spacing, in m, of vertical ordinary stiffeners or girders
- $C_2'$  = Coefficient given in Table 6 depending on  $S_1/d_0$ . For intermediate values of  $S_1/d_0$ ,  $C_2'$  is to be determined by linear interpolation
- $H$  = Value obtained from the following formulae:
  - a) where openings with reinforcement or no opening are provided on solid floors:
    - 1) where slots without reinforcement are provided:
 
$$H = \sqrt{4.0 \frac{d_2}{S_1} - 1.0}$$
 without being taken less than 1.0
    - 2) where slots with reinforcement are provided:  $H = 1.0$
  - b) where openings without reinforcement are provided on solid floors:
    - 1) where slots without reinforcement are provided:

$$H = \left( 1 + 0.5 \frac{\phi}{d_0} \right) \sqrt{4.0 \frac{d_2}{S_1} - 1.0}$$

without being taken less than

$$1 + 0.5 \frac{\phi}{d_0}$$

2) where slots with reinforcement are provided:

$$H = 1 + 0.5 \frac{\phi}{d_0}$$

- $d_2$  = Depth of slots without reinforcement provided at the upper and lower parts of solid floors, in m, whichever is greater  
 $\phi$  = Major diameter of the openings, in m  
 $S_2$  = The smaller of  $S_1$  or  $a$ , in m.

$\frac{B_{DB}}{\ell_{DB}}$	0.4 and under	0.6	0.8	1.0	1.2	1.4	1.6 and over
$C_2$	0.48	0.47	0.45	0.43	0.40	0.37	0.34

$S_1/d_0$	0.3 and under	0.4	0.5	0.6	0.7	0.8	0.9	1.0	1.2	1.4 and over
$C'_2$	64	38	25	19	15	12	10	9	8	7

## 2.4 Stringer of double side structure

### 2.4.1 Net web thickness

The net thickness of stringers in double side structure, in mm, is not to be less than the greatest of either of the value  $t_1$  to  $t_3$  specified in the followings according to each location:

$$t_1 = C_3 \frac{pS|x - x_c|}{(d_0 - d_1)\tau_a} \quad \text{where } |x - x_c| \text{ is under } 0.25\ell_{DS}, |x - x_c| \text{ is to be taken as } 0.25\ell_{DS}$$

$$t_2 = 1.753 \sqrt{\frac{H^2 a^2 \tau_a}{C'_3}} t_1$$

$$t_3 = \frac{8.5S_2}{\sqrt{k}}$$

where :

$p$  = Differential pressure given by the following formula in kN/m<sup>2</sup>:

$$p = |(p_{S,SS} + p_{W,SS}) - (p_{S,LB} + p_{W,LB})|$$

$p_{S,SS}$  = External sea and ballast pressure of side shell plating in still water, in kN/m<sup>2</sup>, as measured vertically at the upper end of hopper tank, longitudinally at the centre of  $\ell_{DS}$ , according to Ch 4, Sec 5 and Ch 4, Sec 6

$p_{W,SS}$  = External sea and ballast pressure of side shell plating due to inertia, in kN/m<sup>2</sup>, as measured vertically at the upper end of hopper tank, longitudinally at the centre of  $\ell_{DS}$ , according to Ch 4, Sec 5 and Ch 4, Sec 6

$p_{S,LB}$  = Ballast pressure of longitudinal bulkhead in still water, in kN/m<sup>2</sup>, as measured vertically at the upper end of hopper tank, longitudinally at the centre of  $\ell_{DS}$ , according to Ch 4, Sec 6

$p_{W,LB}$  = Ballast pressure of longitudinal bulkhead due to inertia, in kN/m<sup>2</sup>, as measured vertically at the upper end of hopper tank, longitudinally at the centre of  $\ell_{DS}$ , according to Ch 4, Sec 6

$S$  = Breadth of part supported by stringer, in m

$d_0$  = Depth of stringers, in m

- $d_1$  = Depth of opening, if any, at the point under consideration, in m.  
 $x_c$  = X co-ordinate, in m, of the center of double side structure under consideration with respect to the reference co-ordinate system defined in Ch 1, Sec 4  
 $\ell_{DS}$  = Length of the double side structure between the transverse bulkheads under consideration, in m  
 $h_{DS}$  = Height of the double side structure between the upper end of hopper tank and the lower end of topside tank, in m  
 $C_3$  = Coefficient obtained from Table 7 depending on  $h_{DS}/\ell_{DS}$ . For intermediate values of  $h_{DS}/\ell_{DS}$ ,  $C_3$  is to be obtained by linear interpolation  
 $a$  = Depth of stringers at the point under consideration, in m. However, where horizontal stiffeners are fitted on the stringer,  $a$  is the distance from the horizontal stiffener under consideration to the side shell plating or the longitudinal bulkhead of double side structure or the distance between the horizontal stiffeners under consideration  
 $S_1$  = Spacing, in m, of transverse ordinary stiffeners or web frames  
 $C'_3$  = Coefficient obtained from Table 8 depending on  $S_1/a$ . For intermediate values of  $S_1/a$ ,  $C'_3$ , is to be obtained by linear interpolation  
 $H$  = Value obtained from the following formulae:  
 — where the stringer is provided with an unreinforced opening:  

$$H = 1 + 0.5 \frac{\phi}{\alpha}$$
  
 — in other cases:  $H = 1.0$   
 $\phi$  = Major diameter of the openings, in m  
 $\alpha$  = The greater of  $a$  or  $S_1$ , in m  
 $S_2$  = The smaller of  $a$  or  $S_1$ , in m

$\frac{h_{DS}}{\ell_{DS}}$	0.5 and under	0.6	0.7	0.8	0.9	1.0	1.1	1.2	1.3 and over
$C_3$	0.16	0.23	0.30	0.36	0.41	0.44	0.47	0.50	0.54

$\frac{S_1}{a}$	0.3 and under	0.4	0.5	0.6	0.7	0.8	0.9	1.0	1.2	1.4 and over
$C'_3$	64	38	25	19	15	12	10	9	8	7

## 2.5 Transverse web in double side structure

### 2.5.1 Net web thickness

The net thickness of transverse webs in double side structure, in mm, is not to be less than the greatest of either of the value  $t_1$  to  $t_3$  specified in the followings according to each location:

$$t_1 = C_4 \frac{pSh_{DS}}{(d_0 - d_1)\tau_a} \left( 1 - 1.75 \frac{z - z_{BH}}{h_{DS}} \right)$$

where  $z - z_{BH}$  is greater than  $0.4h_{DS}$ ,  $z - z_{BH}$  is to be taken as  $0.4h_{DS}$

$$t_2 = 1.753 \sqrt{\frac{H^2 a^2 \tau_a}{C'_4}} t_1$$

$$t_3 = \frac{8.5S_2}{\sqrt{k}}$$

where :

$S$  = Breadth of part supported by transverses, in m

- $d_0$  = Depth of transverses, in m  
 $d_1$  = Depth of opening at the point under consideration, in m  
 $C_4$  = Coefficient obtained from Table 9 depending on  $h_{DS}/\ell_{DS}$ . For intermediate values of,  $C_4$  is to be obtained by linear interpolation  
 $z_{BH}$  = Z co-ordinates, in m, of the upper end of hopper tank with respect to the reference co-ordinate system defined in Ch 1, Sec 4  
 $p, h_{DS}, \ell_{DS}$  = as defined in the requirements of [2.4.1]  
 $a$  = Depth of transverses at the point under consideration, in m. However, where vertical stiffeners are fitted on the transverse,  $a$  is the distance from the vertical stiffener under consideration to the side shell or the longitudinal bulkhead of double side hull or the distance between the vertical stiffeners under consideration.  
 $S_1$  = Spacing, in m, of horizontal ordinary stiffeners or stringers  
 $C'_4$  = Coefficient obtained from Table 10 depending on  $S_1/a$ . For intermediate values of  $S_1/a$ ,  $C'_4$  is to be obtained by linear interpolation.  
 $H$  = Value obtained from the following formulae:  
 — where the transverse is provided with an unreinforced opening:  

$$H = 1 + 0.5 \frac{\phi}{\alpha}$$
  
 — in other cases:  

$$H = 1.0$$
  
 $\phi$  = Major diameter of the openings, in m  
 $\alpha$  = The greater of  $S_1$  or  $a$ , in m  
 $S_2$  = The smaller of  $S_1$  or  $a$ , in m

$\frac{h_{DS}}{\ell_{DS}}$	0.5 and under	0.6	0.7	0.8	0.9	1.0	1.1	1.2	1.3 and over
$C_4$	0.62	0.61	0.59	0.55	0.52	0.49	0.46	0.43	0.41

$\frac{S_1}{a}$	0.3 and under	0.4	0.5	0.6	0.7	0.8	0.9	1.0	1.2	1.4 and over
$C'_4$	64	38	25	19	15	12	10	9	8	7

## 2.6 Primary supporting member in bilge hopper tanks and topside tanks and other structures

### 2.6.1 Load calculation point

For horizontal members, the lateral pressure and hull girder stress, if any, are to be calculated at mid-span of the primary supporting members considered, unless otherwise specified.

For vertical members, the lateral pressure  $p$  is to be calculated as the maximum between the values obtained at mid-span and the pressure obtained from the following formula:

—  $p = \frac{p_U + p_L}{2}$ , when the upper end of the vertical member is below the lowest zero pressure level

—  $p = \frac{\ell_1 p_L}{\ell} \frac{p_L}{2}$ , when the upper end of the vertical member is at or above the lowest zero pressure level (see Fig 1)

where:

- $\ell_1$  = Distance, in m, between the lower end of vertical member and the lowest zero pressure level  
 $p_U, p_L$  = Lateral pressures at the upper and lower end of the vertical member span  $\ell$ , respectively.

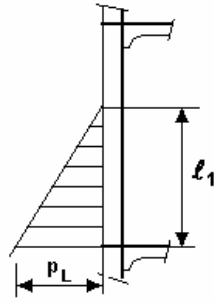

**Fig. 1**  
**Definition of pressure for vertical members**

### 2.6.2 Boundary conditions

The requirements of this sub-article apply to primary supporting members considered as clamped at both ends. For boundary conditions deviated from the above, the yielding check is to be considered on a case by case basis.

### 2.6.3 Net section modulus, net shear sectional area and web thickness under intact conditions

The net section modulus  $w$ , in  $\text{cm}^3$ , the net shear sectional area  $A_{sh}$ , in  $\text{cm}^2$ , and the net web thickness  $t_w$ , in mm, subjected to lateral pressure are to be not less than the values obtained from the following formulae:

$$w = \frac{(p_S + p_W)s\ell^2}{m\lambda_S R_Y} 10^3$$

$$A_{sh} = \frac{5(p_S + p_W)s\ell}{\tau_a \sin \phi}$$

$$t_w = 1.75 \cdot \sqrt[3]{\frac{h_w \tau_a}{10^4 C_5} A_{sh}}$$

where:

$\lambda_S$  = Coefficient defined in Table 11

$\phi$  = Angle, in deg, between the primary supporting member web and the shell plate, measured at the middle of the member span; the correction is to be applied when  $\phi$  is less than 75 deg.

$C_5$  = Coefficient defined in Table 12 according to  $s_1$  and  $d_0$ . For intermediate values of  $s_1/d_0$ , coefficient  $C_5$  is to be obtained by linear interpolation.

$s_1$  = Spacing of stiffeners or tripping brackets on web plate, in m

$d_0$  = Spacing of stiffeners parallel to shell plate on web plate, in m.

Table 11 Coefficient $\lambda_S$	
Primary supporting members	Coefficient $\lambda_S$
Longitudinal members contributing to the hull girder longitudinal strength	$1.1 \left( 1.0 - 0.85 \left  \frac{\sigma_X}{R_Y} \right  \right)$ without being taken greater than 0.8
Other members	0.8

Table 12 Coefficient $C_5$										
$s_1/d_0$	0.3 and less	0.4	0.5	0.6	0.7	0.8	0.9	1.0	1.5	2.0 and over
$C_5$	60.0	40.0	26.8	20.0	16.4	14.4	13.0	12.3	11.1	10.2



### 3 Additional requirements for primary supporting members of BC-A and BC-B ships

#### 3.1 Evaluation of double bottom capacity and allowable hold loading in flooded conditions

##### 3.1.1 Shear capacity of the double bottom

The shear capacity of the double bottom is to be calculated as the sum of the shear strength at each end of:

- all floors adjacent to both hopper tanks, less one half of the shear strength of the two floors adjacent to each stool, or transverse bulkhead if no stool is fitted (see Fig 2); the floor shear strength is to be calculated according to [3.1.2]
- all double bottom girders adjacent to both stools, or transverse bulkheads if no stool is fitted; the girder shear strength is to be calculated according to [3.1.3].

Where in the end holds, girders or floors run out and are not directly attached to the boundary stool or hopper tank girder, their strength is to be evaluated for the one end only.

The floors and girders to be considered in calculating the shear capacity of the double bottom are those inside the hold boundaries formed by the hopper tanks and stools (or transverse bulkheads if no stool is fitted). The hopper tank side girders and the floors directly below the connection of the stools (or transverse bulkheads if no stool is fitted) to the inner bottom may not be included.

When the geometry and/or the structural arrangement of the double bottom is/are such as to make the above assumptions inadequate, the shear capacity of the double bottom is to be calculated by means of direct calculations to be carried out according to the requirements specified in Ch 7, as far as applicable.

##### 3.1.2 Floor shear strength

The floor shear strength, in kN, is to be obtained from the following formulae:

- in way of the floor panel adjacent to the hopper tank:

$$S_{f1} = A_f \frac{\tau_A}{\eta_1} 10^{-3}$$

- in way of the openings in the outermost bay (i.e. that bay which is closer to the hopper tank):

$$S_{f2} = A_{f,h} \frac{\tau_A}{\eta_2} 10^{-3}$$

where:

$A_f$  = Net sectional area, in mm<sup>2</sup>, of the floor panel adjacent to the hopper tank

$A_{f,h}$  = Net sectional area, in mm<sup>2</sup>, of the floor panels in way of the openings in the outermost bay (i.e. that bay which is closer to the hopper tank)

$\tau_A$  = Allowable shear stress, in N/mm<sup>2</sup>, equal to the lesser of:

$$\tau_A = 0.645 \frac{R_{eH}^{0.6}}{(s/t_N)^{0.8}}$$

and

$$\tau_A = \frac{R_{eH}}{\sqrt{3}}$$

$t_N$  = Floor web net thickness, in mm

$s$  = Spacing, in m, of stiffening members of the panel considered

$\eta_1$  = Coefficient to be taken equal to 1.1

$\eta_2$  = Coefficient to be taken equal to 1.2. It may be reduced to 1.1 where appropriate reinforcements are fitted in way of the openings in the outermost bay, to be examined by the Society on a case-by-case basis.

##### 3.1.3 Girder shear strength

The girder shear strength, in kN, is to be obtained from the following formulae:

— in way of the girder panel adjacent to the stool (or transverse bulkhead, if no stool is fitted):

$$S_{g1} = A_g \frac{\tau_A}{\eta_1} 10^{-3}$$

— in way of the largest opening in the outermost bay (i.e. that bay which is closer to the stool, or transverse bulk-head, if no stool is fitted):

$$S_{g2} = A_{g,h} \frac{\tau_A}{\eta_2} 10^{-3}$$

$A_g$  = Net sectional area, in mm<sup>2</sup>, of the girder panel adjacent to the stool (or transverse bulkhead, if no stool is fitted)

$A_{g,h}$  = Net sectional area, in mm<sup>2</sup>, of the girder panel in way of the largest opening in the outermost bay (i.e. that bay which is closer to the stool, or transverse bulkhead, if no stool is fitted)

$\tau_A$  = Allowable shear stress, in N/mm<sup>2</sup>, defined in [3.1.2], where  $t_N$  is the girder web net thickness

$\eta_1$  = Coefficient to be taken equal to 1.1

$\eta_2$  = Coefficient to be taken equal to 1.15. It may be reduced to 1.1 where appropriate reinforcements are fitted in way of the largest opening in the outermost bay, to be examined by the Society on a case-by-case basis.

### 3.1.4 Allowable hold loading

The allowable hold loading is to be obtained, in t, from the following formula:

$$W = \rho_C V \frac{1}{F}$$

where:

F = Coefficient to be taken equal to:

$F = 1.1$  in general

$F = 1.05$  for steel mill products

V = Volume, in m<sup>3</sup>, occupied by cargo at a level  $h_B$

$h_B$  = Level of cargo, in m<sup>2</sup>, to be obtained from the following formula:

$$h_B = \frac{X}{\rho_C g}$$

X = Pressure, in kN/m<sup>2</sup>, to be obtained from the following formulae:

— for dry bulk cargoes, the lesser of:

$$X = \frac{Z + \rho g(z_F - 0.1D_1 - h_F)}{1 + \frac{\rho}{\rho_C}(perm - 1)}$$

$$X = Z + \rho g(z_F - 0.1D_1 - h_F perm)$$

— for steel mill products:

$$X = \frac{Z + \rho g(z_F - 0.1D_1 - h_F)}{1 - \frac{\rho}{\rho_C}}$$

$D_1$  = Distance, in m, from the base line to the freeboard deck at side amidships

$h_F$  = Inner bottom flooding head is the distance, in m, measured vertically with the ship in the upright position, from the inner bottom to a level located at a distance  $z_F$ , in m, from the baseline.

$z_F$  = Flooding level, in m, defined in Ch 4, Sec 6, [3.4.3]

$perm$  = Permeability of cargo, which need not be taken greater than 0.3

Z = Pressure, in kN/m<sup>2</sup>, to be taken as the lesser of:

$$Z = \frac{C_H}{A_{DB,H}}$$

$$Z = \frac{C_E}{A_{DB,E}}$$

- $C_H$  = Shear capacity of the double bottom, in kN, to be calculated according to [3.1.1], considering, for each floor, the lesser of the shear strengths  $S_{f1}$  and  $S_{f2}$  (see [3.1.2]) and, for each girder, the lesser of the shear strengths  $S_{g1}$  and  $S_{g2}$  (see [3.1.3])
- $C_E$  = Shear capacity of the double bottom, in kN, to be calculated according to [3.1.1], considering, for each floor, the shear strength  $S_{f1}$  (see [3.1.2]) and, for each girder, the lesser of the shear strengths  $S_{g1}$  and  $S_{g2}$  (see [3.1.3])

$$— A_{DB,H} = \sum_{i=1}^n S_i B_{DB,i}$$

$$— A_{DB,E} = \sum_{i=1}^n S_i (B_{DB} - s)$$

- $n$  = Number of floors between stools (or transverse bulkheads, if no stool is fitted)
- $S_i$  = Space of  $i$ -th floor, in m
- $B_{DB,i}$  = Length, in m, to be taken equal to :  
 $B_{DB,i} = B_{DB} - s$  for floors for which  $S_{f1} < S_{f2}$  (see [3.1.2])  
 $B_{DB,i} = B_{DB,h}$  for floors for which  $S_{f1} \geq S_{f2}$  (see [3.1.2])
- $B_{DB}$  = Breadth, in m, of double bottom between the hopper tanks (see Fig 3)
- $B_{DB,h}$  = Distance, in m, between the two openings considered (see Fig 3)
- $s$  = Spacing, in m, of inner bottom longitudinal ordinary stiffeners adjacent to the hopper tanks.

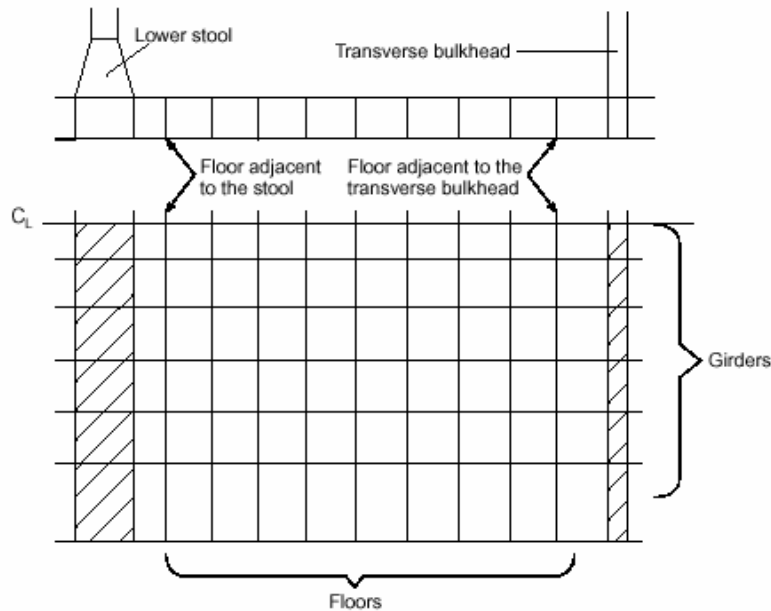

**Fig. 2**  
Double bottom structure

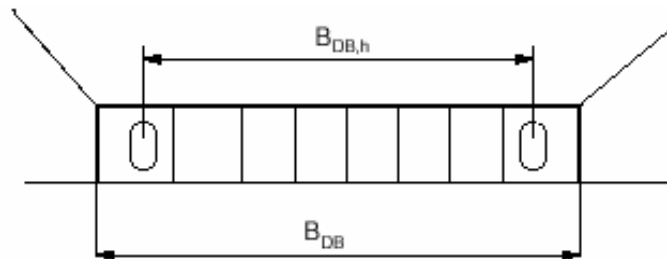

**Fig. 3**  
Dimensions  $B_{DB}$  and  $B_{DB,h}$

## 4 Pillars

### 4.1 Buckling of pillars subjected to compressive axial load

#### 4.1.1 General

It is to be checked that the compressive stress of pillars does not exceed the critical column buckling stress calculated according to [4.1.2].

#### 4.1.2 Critical column buckling stress of pillars

The critical column buckling stress of pillars is to be obtained, in N/mm<sup>2</sup>, from the following formulae:

$$\sigma_{cB} = \sigma_{E1} \quad \text{for } \sigma_{E1} \leq \frac{R_{eH}}{2}$$

$$\sigma_{cB} = R_{eH} \left( 1 - \frac{R_{eH}}{4\sigma_{E1}} \right) \quad \text{for } \sigma_{E1} > \frac{R_{eH}}{2}$$

where:



$\sigma_{E1}$  = Euler column buckling stress, to be obtained, in N/mm<sup>2</sup>, from the following formula:

$$\sigma_{E1} = \pi^2 E \frac{I}{A(fl)^2} 10^{-4}$$

$I$  = Minimum net moment of inertia, in cm<sup>4</sup>, of the pillar

$A$  = Net cross-sectional area, in cm<sup>2</sup>, of the pillar

$f$  = Coefficient to be obtained from Table 13.

Table 13 Coefficient f	
Boundary conditions of the pillar	f
Both ends fixed 	0.5
One end fixed, one end pinned 	$\frac{\sqrt{2}}{2}$
Both ends pinned 	1.0

## APPENDIX 1 BUCKLING AND ULTIMATE STRENGTH

### 1 Application of Ch 6, Sec 3

#### 1.1 General application

##### 1.1.1 Mutable shear stress

If shear stresses are not uniform on the width  $b$  of the elementary plate panel, the greater of the two following values is to be used:

- mean value of  $\tau$
- $0.5\tau_{max}$

##### 1.1.2 Change of thickness within an elementary plate panel

If the plate thickness of an elementary plate panel varies over the width  $b$ , the buckling check may be performed for an equivalent elementary plate panel  $a \times b'$  having a thickness equal to the smaller plate thickness  $t_1$ .

The width of this equivalent elementary plate panel is defined by the following formula:

$$b' = b_1 + b_2 \left( \frac{t_1}{t_2} \right)^{1.5}$$

where:

- $b_1$  = Width of the part of the elementary plate panel with the smaller plate thickness  $t_1$
- $b_2$  = Width of the part of the elementary plate panel with the greater plate thickness  $t_2$

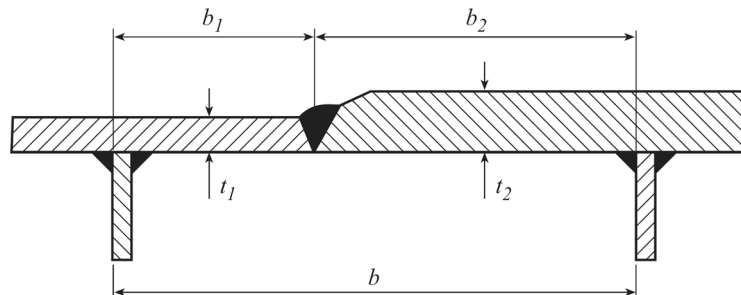
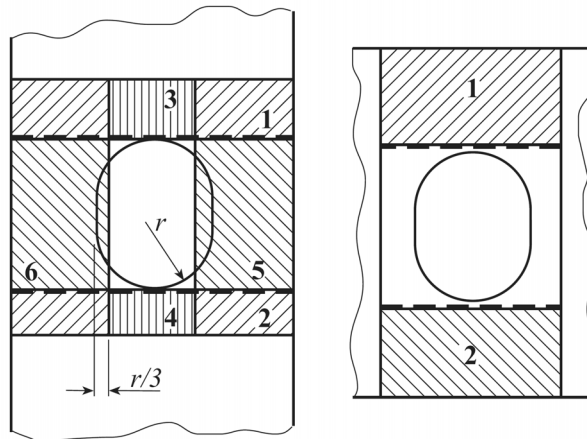

**Fig. 1**  
Plate thickness change within the field breadth

##### 1.1.3 Evaluation of floors or other high girders with holes

The following procedure may be used to assess high girders with holes:

- a) Divide the plate field in sub elementary plate panels according the Fig 2
- b) Assess the elementary plate panel and all sub elementary plate panels separately with the following boundary conditions:
  - for sub panels 1 to 4: all edges are simply supported (load cases 1 and 2 in Ch 6, Sec 3, Table 2)
  - for sub panels 5 and 6: simply supported, one side free (load case 3 in Ch 6, Sec 3, Table 2).



**Fig. 2**  
 Elementary plate panels of high girder with hole

## 1.2 Application to hull transverse section analysis

### 1.2.1 Idealization of elementary plate panels

The buckling check of the elementary plate panel is to be performed under the loads defined in Ch 6, Sec 3, [2.1], according to the requirements of Ch 6, Sec 3, [3].

The determination of the buckling and reduction factors is made according to the Ch 6, Sec 3, Table 2 for the plane plate panel and Ch 6, Sec 3, Table 3 for the curved plate panel.

For the determination of the buckling and reduction factors in Ch 6, Sec 3, Table 2, the following cases are to be used according to the type of stresses and framing system of the plating:

- For the normal compressive stress:
  - Buckling load case 1 for longitudinally framed plating, the membrane stress in  $x$ -direction  $\sigma_x$  being the normal stress  $\sigma_n$  defined in Ch 6, Sec 3, [2.1.2]
  - Buckling load case 2 for transversely framed plating, the membrane stress in  $y$ -direction  $\sigma_y$  being the normal stress  $\sigma_n$  defined in Ch 6, Sec 3, [2.1.2], and the values  $a$  and  $b$  being exchanged to obtain  $\alpha$  value greater than 1 as it is considered in load case 2.
- For the shear stress: Buckling case 5,  $\tau$  being the shear stress  $\tau_{SF}$  defined in Ch 6, Sec 3, [2.1.3].

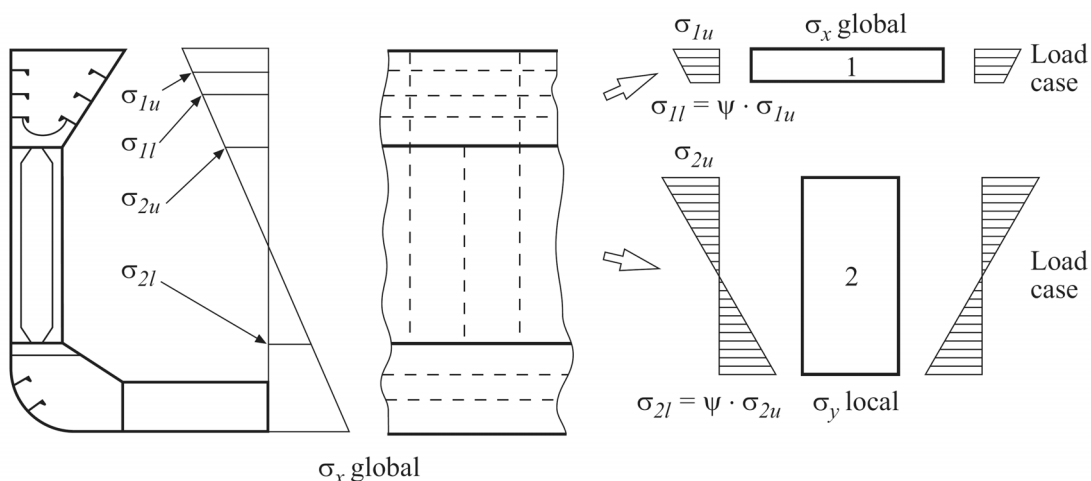

**Fig. 3**  
 Idealization of elementary plate panels

### 1.2.2 Ordinary stiffeners

The buckling check of the longitudinal and transverse ordinary stiffeners of partial and total plate panels is to be performed under the loads defined in Ch 6, Sec 3, [2.1], according to Ch 6, Sec 3, [4] with:

- $\sigma_x$  = normal stress  $\sigma_n$  defined in Ch 6 Sec 3, [2.1.2]
- $\sigma_y = 0$ .

The effective width of the attached plating of the stiffeners is to be determined in accordance with Ch 6, Sec 3, [5]. A constant stress is to be assumed corresponding to the greater of the following values:

- stress at half length of the stiffener
- 0.5 of the maximum compressive stress of adjacent elementary plate panels.

### 1.2.3 Primary supporting members with stiffeners in parallel

The effective width of the attached plating of the primary supporting members is to be determined in accordance with Ch 6, Sec 3, [5.2].

In addition, when ordinary stiffeners are fitted on the attached plate and parallel to a primary supporting member, the buckling check is to consider a moment of inertia  $I_x$  taking account the moments of inertia of the parallel ordinary stiffeners connected to its attached plate (see Ch 6, Sec 3, Fig 3).

### 1.2.4 Primary supporting members with stiffener perpendicular to girder

The effective width of the attached plating of the primary supporting members is to be determined in accordance with Ch 6, Sec 3, [5.2].

In addition, when ordinary stiffeners are fitted on the attached plate and perpendicular to a primary supporting member, the buckling check is to consider a moment of inertia  $I_x$  taking account the effective width according to (see Ch 6, Sec 3, Fig. 4).

## 1.3 Additional application to FEM analysis

### 1.3.1 Non uniform compressive stresses along the length of the buckling panel

If compressive stresses are not uniform over the length of the unloaded plate edge (e.g. in case of girders subjected to bending), the compressive stress value is to be taken at a distance of  $b/2$  from the transverse plate edge having the largest compressive stress (see Fig 4). This value is not to be less than the average value of the compressive stress along the longitudinal edge.

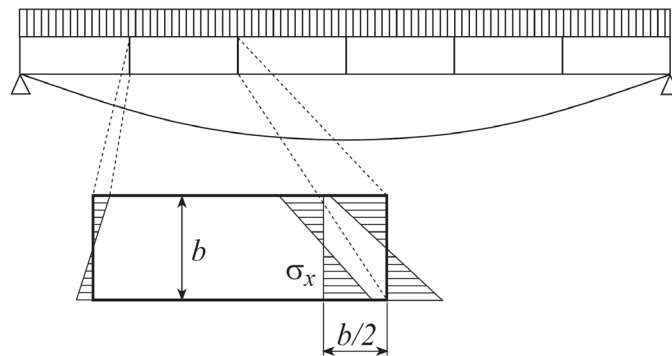
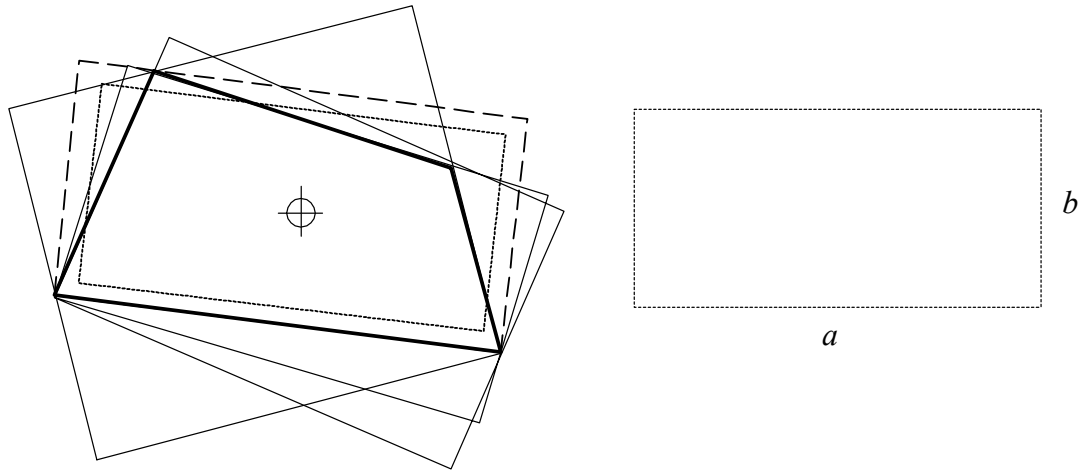

Fig. 4  
Non uniform compressive stress along longitudinal edge  $a$

### 1.3.2 Buckling stress calculation of non rectangular elementary plate panels

#### a) Quadrilateral panels

According to Fig 5, rectangles that completely surround the irregular buckling panel are searched. Among several possibilities the rectangle with the smallest area is taken. This rectangle is shrunk to the area of the original panel, where the aspect ratio and the centre are maintained. This leads to the final rectangular panel with the dimensions  $a$ ,  $b$ .



- Original irregular panel ( ——— )
- Intermediate rectangles ( ——— )
- Rectangle with smallest area ( - - - - )
- Final rectangle ( ..... )

**Fig. 5**  
 Approximation of non rectangular elementary plate panels

b) Trapezoidal elementary plate panel

A rectangle is derived with  $a$  being the mean value of the bases and  $b$  being the height of the original panel.

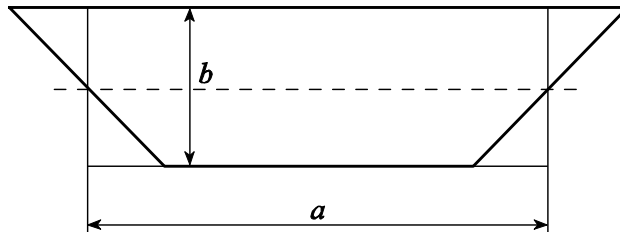

**Fig. 6**  
 Approximation of trapezoidal elementary plate panel

c) Right triangle

The legs of the right triangle are reduced by  $\sqrt{0.5}$  to obtain a rectangle of same area and aspect ratio.

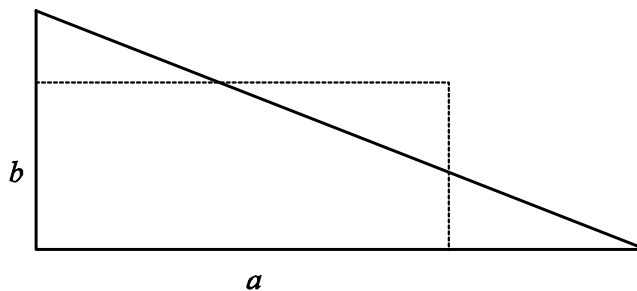

**Fig. 7**  
 Approximation of right triangle

d) General triangle

General triangle is treated according to a) above.

**1.3.3 Buckling assessment of side shell plates**

In order to assess the buckling criteria for vertically stiffened side shell plating, the following cases have to be considered:



In case vertical and shear stresses are approximately constant over the height of the elementary plate panel:

- Buckling load cases 1, 2 and 5, according to Ch 6, Sec 3, Table 2 are to be considered
- $\psi = f(\sigma_1, \sigma_2)$  for horizontal stresses
- $\psi = 1.0$  for vertical stresses
- $t = t_{min}$  (Elementary plate panel)

In case of distributed horizontal, vertical and shear stresses over the height of the elementary plate panel, the following stress situations are to be considered separately:

a) Pure vertical stress

- The size of buckling field to be considered is  $b$  times  $b$  ( $\alpha = 1$ )
- $\psi = 1.0$
- The maximum vertical stress in the elementary plate panel is to be considered in applying the criteria.

b) Shear stress associated to vertical stress

- The size of buckling field to be considered is  $2b$  times  $b$  ( $\alpha = 2$ )
- $\psi = 1.0$
- The following two stress combinations are to be considered:
  - The maximum vertical stress in the elementary plate panel plus the shear stress and longitudinal stress at the location where maximum vertical stress occurs
  - The maximum shear stress in the elementary plate panel plus the vertical stress and longitudinal stress at the location where maximum shear stress occurs
- The plate thickness  $t$  to be considered is the one at the location where the maximum vertical/shear stress occurs.

c) Distributed longitudinal stress associated with vertical and shear stress

- The actual size of the elementary plate panel is to be used ( $\alpha = f(a, b)$ )
- The actual edge factor  $\psi$  for longitudinal stress is to be used
- The average values for vertical stress and shear stress are to be used.
- $t = t_{min}$  (Elementary plate panel).

### 1.3.4 Buckling assessment of corrugated bulkheads

The transverse elementary plate panel (face plate) is to be assessed using the normal stress parallel to the corrugation. The slanted elementary plate panel (web plate) is to be assessed using the combination of normal and shear stresses.

The plate panel breadth  $b$  is to be measured according to Fig 8.

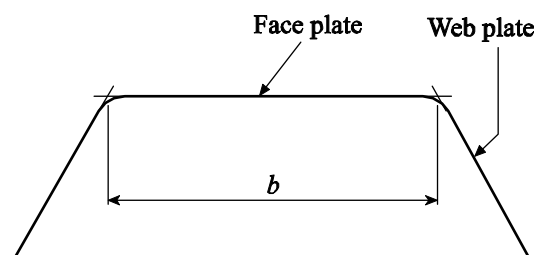

**Fig. 8**  
Measuring  $b$  of corrugated bulkheads

a) Face plate assessment

- The buckling load case 1, according to Ch 6, Sec 3, Table 2, is to be used
- The size of the buckling field to be considered is  $b$  times  $b$  ( $\alpha = 1$ )
- $\psi = 1.0$
- The maximum vertical stress in the elementary plate panel is to be considered in applying the criteria
- The plate thickness  $t$  to be considered is the one at the location where the maximum vertical stress occurs

b) Web plate assessment

- The buckling load cases 1 and 5, according to Ch 6, Sec 3, Table 2, are to be used.

- The size of the buckling field to be considered is  $2b$  times  $b$  ( $\alpha = 2$ )
- $\psi = 1.0$
- The following two stress combinations are to be considered:
  - The maximum vertical stress in the elementary plate panel plus the shear stress and longitudinal stress at the location where maximum vertical stress occurs
  - The maximum shear stress in the elementary plate panel plus the vertical stress and longitudinal stress at the location where maximum shear stress occurs
- The plate thickness  $t$  to be considered is the one at the location where the maximum vertical/shear stress occurs.

# Chapter 7

## Direct Strength Analysis

---

- Section 1 Direct Strength Assessment of the Primary Supporting Members
- Section 2 Global strength FE analysis of cargo hold structures
- Section 3 Detailed Stress Assessment
- Section 4 Hot Spot Stress Analysis for Fatigue Strength Assessment
- Appendix 1 Longitudinal Extent of the Finite Element Models
- Appendix 2 Displacement Based Buckling Assessment in Finite Element Analysis



# SECTION 1

## DIRECT STRENGTH ASSESSMENT OF THE PRIMARY SUPPORTING MEMBERS

### 1 General

#### 1.1 Application

##### 1.1.1

Direct strength assessment of primary supporting members based on a three-dimensional (3D) finite element (FE) analysis is to be applied to ships having length  $L$  of 150 m or above.

##### 1.1.2

Three kinds of FE analysis procedures are specified in this Chapter:

- a) global strength FE analysis (first FE analysis step) to assess global strength of primary supporting members of the cargo hold structure, according to Sec 2.
- b) detailed stress assessment (second FE analysis step) to assess highly stressed areas with refined meshes, according to Sec 3
- c) hot spot stress analysis (third FE analysis step) to calculate hot spot stresses at stress concentration points with very fine meshes for fatigue strength assessment, according to Sec 4.

A flowchart of FE analysis procedure for direct strength assessment is shown in Fig 1.

#### 1.2 Computer program

##### 1.2.1

Computer programs for FE analysis are to be suitable for the intended analysis. Reliability of unrecognized programs is to be demonstrated to the satisfaction of the Society prior to the commencement of the analysis.

#### 1.3 Submission of analysis report

##### 1.3.1

A detailed report of direct strength FE analysis is to be submitted, including background information of the analysis. This report is to include the following items:

- a) list of drawings/plans used in the analysis, including their versions and dates
- b) detailed description of structural modeling principles and any deviations in the model from the actual structures
- c) plots of structural model
- d) material properties, plate thickness and beam properties used in the model
- e) details of boundary conditions
- f) all loading conditions analyzed
- g) data for loads application
- h) summaries and plots of calculated deflections
- i) summaries and plots of calculated stresses
- j) details of buckling strength assessment
- k) tabulated results showing compliance with the design criteria
- l) reference of the finite element computer program, including its version and date.

#### 1.4 Net scantling

##### 1.4.1

Direct strength analysis is to be based on the net scantling approach according to Ch 3, Sec 2.

## 1.5 Applied loads

### 1.5.1 Design loads

Direct strength analysis is to be carried out by applying design loads given in Ch 4 at a probability level of  $10^{-8}$ , except for fatigue strength assessment where probability level is  $10^{-4}$ . Combination of static and dynamic loads which are likely to impose the most severe load regime are to be applied to the 3D FE model.

### 1.5.2 Structural weight

Effect of the hull structure weight is to be included in static loads, but is not to be included in dynamic loads. Standard density of steel is to be taken as  $7.85 \text{ t/m}^3$ .

### 1.5.3 Loading conditions

The loading conditions specified in Ch 4, Sec 7 are to be considered in 3D FE analysis.

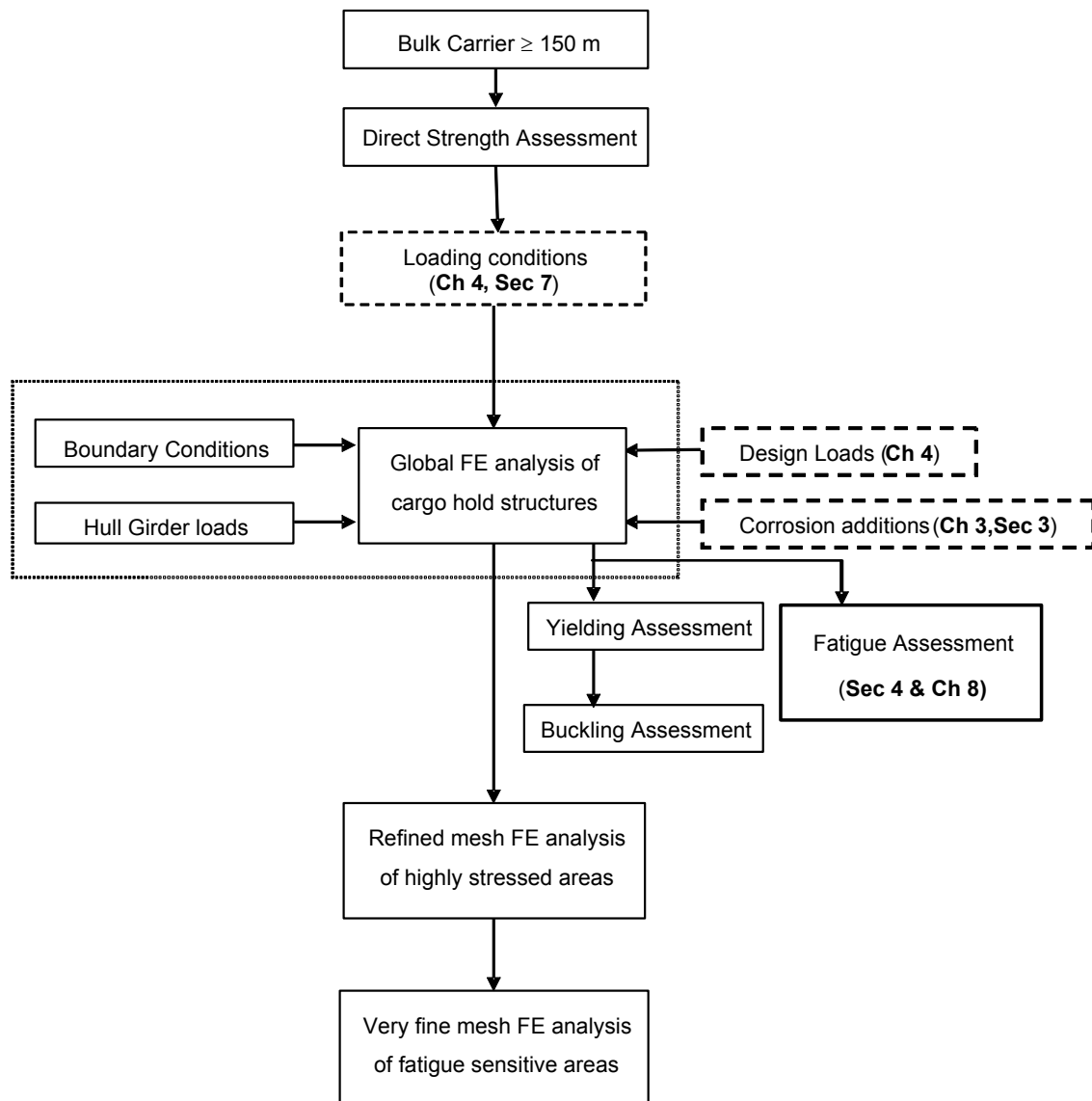

Fig. 1  
Flowchart of FE analysis procedure

## SECTION 2 GLOBAL STRENGTH FE ANALYSIS OF CARGO HOLD STRUCTURES

### Symbols

For symbols not defined in this Section, refer to Ch 1, Sec 4.

$M_{SW}$	=	Design vertical bending moment as defined in Ch 4, Sec 7, Table 2.
$M_{WV}$	=	Vertical wave bending moment, in hogging or sagging condition, as defined in Ch 4, Sec 3, [3.1.1]
$M_{WH}$	=	Horizontal wave bending moment, as defined in Ch 4, Sec 3, [3.3.1]
$Q_{SW}$	=	Allowable still water shear force at the considered bulkhead position as provided in Ch 4, Sec 7, Table 3
$Q_{WV}$	=	Vertical wave shear force as defined in Ch 4, Sec 3, [3.2.1]
$C_{WV}, C_{WH}$	=	Load combination factors, as defined in Ch 4, Sec 4, Table 3.

### 1 General

#### 1.1 Application

The procedure given in this Section focuses on direct strength analysis of cargo hold structures in midship area. The global strength FE analysis of cargo hold structures is intended to verify that the following are within the acceptance criteria under the applied static and dynamic loads:

- stress level in the hull girder and primary supporting members
- buckling capability of primary supporting members
- deflection of primary supporting members.

### 2 Analysis model

#### 2.1 Extent of model

##### 2.1.1

The longitudinal extent of FE model is to cover three cargo holds and four transverse bulkheads. The transverse bulkheads at the ends of the model extent are to be included, together with their associated stools. Both ends of the model are to form vertical planes and to include any transverse web frames on the planes if any. The details of the extent of the model are given in App 1.

##### 2.1.2

FE model is to include both sides of ship structures considering unsymmetrical wave-induced loads in the transverse direction.

##### 2.1.3

All main structural members are to be represented in FE model. These include inner and outer shell, floor and girder system in double bottom, transverse and vertical web frames, stringers, transverse and longitudinal bulkhead structures. All plates and stiffeners on these structural members are to be modelled.

#### 2.2 Finite element modeling

##### 2.2.1

All main structural members (plates and stiffeners) detailed in [2.1.3] are to be represented in FE model.

##### 2.2.2

Mesh boundaries of finite elements are to simulate the stiffening systems on the actual structures as far as practical and are to represent the correct geometry of the panels between stiffeners.

### 2.2.3

Stiffness of each structural member is to be represented correctly by using proper element type for the structural member. The principle for selection of element type is given below.

- 1) Stiffeners are to be modeled by beam or bar element having axial, torsional, bi-directional shear and bending stiffness. However, web stiffeners and face plates of primary supporting members may be modeled by rod element having only axial stiffness and a constant cross-sectional area along its length.
- 2) Plates are to be modeled by shell element having out-of-plane bending stiffness in addition to bi-axial and in-plane stiffness. However, membrane element having only bi-axial and in-plane stiffness can be used for plates that are not subject to lateral pressures.

For membrane and shell elements, only linear quad or triangle elements, as shown in Fig 1, are to be adopted.

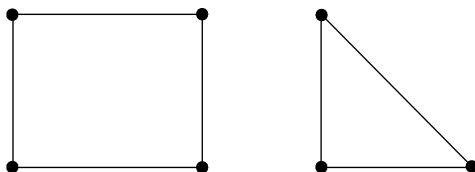

**Fig. 1**  
**Linear membrane and shell quad and triangle elements**

Triangle elements are to be avoided as far as possible, especially in highly stressed areas and in such areas around openings, at bracket connections and at hopper connections where significant stress gradient should be predicted.

- 3) Stiffened panels may be modeled by two-dimensional (2D) orthotropic elements that can represent the stiffness of the panels properly.

### 2.2.4

When orthotropic elements are not used in FE model:

- mesh size is to be equal to or less than the representative spacing of longitudinal stiffeners or transverse side frames
- stiffeners are to be modeled by using rod and/or beam/bar elements
- webs of primary supporting members are to be divided by at least three elements height-wise. However, for transverse primary supporting members inside hopper tank and top side tank, which are less in height than the space between ordinary longitudinal stiffeners, two elements on the height of primary supporting members are accepted.
- side shell frames and their end brackets are to be modeled by using shell elements for web and shell/beam/rod elements for face plate. Webs of side shell frames need not be divided along the direction of depth
- aspect ratio of elements is not to exceed 1:4.

An example of typical mesh is given in App 1.

### 2.2.5

When orthotropic elements are used in FE model for stiffened panels:

- for the members such as the double bottom girder or floor, the element height is to be the double bottom height.
- where a stiffener is located along the edge between two orthotropic elements, either it is to be modelled by using beam/rod element, or it is virtually modelled by reporting the stiffness of the stiffener onto the two orthotropic elements
- where a stiffener is located along the edge between an orthotropic element and a membrane/shell element, it is to be modelled by using beam/rod element
- where a stiffener is located along the edge between two membrane/shell elements, it is to be modelled by using beam/rod element
- where a double hull is fitted, the web of the primary supporting members is to be modelled with one element on its height
- where no double hull construction is fitted, at least one over three frame and its associated end brackets are to be modelled by using shell elements for the webs and shell/beam elements for the flanges
- the aspect ratio of the elements is not to exceed 1:2.



## 2.3 Boundary conditions

### 2.3.1

Both ends of the model are to be simply supported according to Table 1 and Table 2. The nodes on the longitudinal members at both end sections are to be rigidly linked to independent points at neutral the axis on the centreline as shown in Table 1. The independent points of both ends are to be fixed as shown in Table 2.

Nodes on longitudinal members at both ends of the model	Translational			Rotational		
	<i>Dx</i>	<i>Dy</i>	<i>Dz</i>	<i>Rx</i>	<i>Ry</i>	<i>Rz</i>
All longitudinal members	RL	RL	RL	-	-	-

RL means rigidly linked to the relevant degrees of freedom of the independent point

Location of the independent point	Translational			Rotational		
	<i>Dx</i>	<i>Dy</i>	<i>Dz</i>	<i>Rx</i>	<i>Ry</i>	<i>Rz</i>
Independent point on aft end of model	-	Fix	Fix	Fix	-	-
Independent point on fore end of model	Fix	Fix	Fix	Fix	-	-

## 2.4 Loading conditions

### 2.4.1 General

The loading conditions, combined with loading patterns and load cases, as illustrated in Ch 4, App 2, are to be considered as mandatory conditions for the conventional designs.

## 2.5 Consideration of hull girder loads

### 2.5.1 General

Each loading condition is to be associated with its corresponding hull girder loads. The load combination is to be considered using Load Combination Factors (LCFs) of the wave-induced vertical and horizontal bending moments and of the wave-induced vertical shear forces specified in Ch 4, Sec 4 for each Load Case.

### 2.5.2 Vertical bending moment analysis

Vertical bending moment analysis is to be performed for cases listed in Ch 4, Sec 7, Table 2, the minimum required cases being listed in Ch 4, App 2.

In vertical bending moment analysis the target hull girder loads are the maximum vertical bending moments which may occur at the centre of the mid-hold in the FE model. The target values of hull girder loads are to be obtained in accordance with Table 3 with considering still water vertical bending moments specified in Ch 4, Sec 7, Table 2, and in Ch 4, App 2.

Hull girder effect	Still water	Wave	Considered Location
Vertical bending moment	$M_{SW}$	$C_{WV} M_{WV}$	Centre of mid-hold
Vertical shear force	0	0	Centre of mid-hold
Horizontal bending moment	---	$C_{WH} M_{WH}$	Centre of mid-hold
Horizontal shear force	---	0	Centre of mid-hold

### 2.5.3 Vertical shear force analysis

Vertical shear force analysis is to be performed for cases listed in Ch 4, Sec 7, Table 3, the minimum required cases being listed in Ch 4, App 2.

In vertical shear force analysis the target hull girder loads are the maximum vertical shear force which may occur at one of the transverse bulkheads of the mid-hold in the FE model. Reduced vertical bending moments are considered simultaneously. The target values of hull girder loads are to be obtained in accordance with Table 4 with considering still water vertical bending moments and shear forces specified in Ch 4, Sec 7, Table

2 and Ch 4, Sec 7, Table 3, and in Ch 4, App 2.

<i>Hull girder effect</i>	<i>Still water</i>	<i>Wave</i>	<i>Location</i>
Vertical bending moment	$0.8M_{SW}$	$0.65 C_{WV} M_{WV}$	Transverse bulkhead
Vertical shear force	$Q_{SW}$	$Q_{WV}$	Transverse bulkhead
Horizontal bending moment	---	0	Transverse bulkhead
Horizontal shear force	---	0	Transverse bulkhead

#### 2.5.4 Influence of local loads

The distribution of hull girder shear force and bending moment induced by local loads applied on the model are calculated using a simple beam theory for the hull girder.

Reaction forces at both ends of the model and distributions of shearing forces and bending moments induced by local loads can be determined by following formulae:

$$R_{V\_fore} = -\frac{\sum_i (x_i - x_{aft}) \vec{f}_i \cdot \vec{z}}{x_{fore} - x_{aft}} \quad R_{V\_aft} = \sum_i \vec{f}_i \cdot \vec{z} + R_{V\_fore}$$

$$R_{H\_fore} = \frac{\sum_i (x_i - x_{aft}) \vec{f}_i \cdot \vec{y}}{x_{fore} - x_{aft}} \quad R_{H\_aft} = -\sum_i \vec{f}_i \cdot \vec{y} + R_{H\_fore}$$

$$Q_{V\_FEM}(x) = R_{V\_aft} - \sum_i \vec{f}_i \cdot \vec{z} \quad \text{when } x_i < x$$

$$Q_{H\_FEM}(x) = R_{H\_aft} + \sum_i \vec{f}_i \cdot \vec{y} \quad \text{when } x_i < x$$

$$M_{V\_FEM}(x) = (x - x_{aft}) R_{V\_aft} - \sum_i (x - x_i) \vec{f}_i \cdot \vec{z} \quad \text{when } x_i < x$$

$$M_{H\_FEM}(x) = (x - x_{aft}) R_{H\_aft} + \sum_i (x - x_i) \vec{f}_i \cdot \vec{y} \quad \text{when } x_i < x$$

where:

$x_{aft}$  = Location of the aft end support,  
 $x_{fore}$  = Location of the fore end support,  
 $x$  = Considered location,

$R_{V\_aft}$ ,  $R_{V\_fore}$ ,  $R_{H\_aft}$  and  $R_{H\_fore}$  = Vertical and horizontal reaction forces at the fore and aft ends

$Q_{V\_FEM}$ ,  $Q_{H\_FEM}$ ,  $M_{V\_FEM}$  and  $M_{H\_FEM}$  = Vertical and horizontal shear forces and bending moments created by the local loads applied on the FE model. Sign of  $Q_{V\_FEM}$ ,  $M_{V\_FEM}$  and  $M_{H\_FEM}$  is in accordance with the sign convention defined in Ch 4, Sec 3. The sign convention for reaction forces is that a positive creates a positive shear force.

$\vec{f}_i$  = Applied force on node i due to all local loads,  
 $x_i$  = Longitudinal coordinate of node i.

#### 2.5.5 Methods to account for hull girder loads

For bending moment analysis, two alternative methods can be used to consider the hull girder loads/stresses in the assessment of the primary supporting members:

- to add the hull girder loads directly to FE model (direct method), or
- to superimpose the hull girder stresses separately onto the stresses obtained from the structural analysis using the lateral loads (superimposition method).

For shear force analysis, the “direct method” is to be used.

### 2.5.6 Direct method

In direct method the effect of hull girder loads are directly considered in 3D FE model. The equilibrium loads are to be applied at both model ends in order to consider the hull girder loads as specified in [2.5.2] and [2.5.3] and influence of local loads as specified in [2.5.4].

In order to control the shear force at the target locations, two sets of enforced moments are applied at both ends of the model. These moments are calculated by following formulae:

$$M_{Y\_aft\_SF} = M_{Y\_fore\_SF} = \frac{(x_{fore} - x_{aft})}{2} [Q_{V\_T}(x_{eq}) - Q_{V\_FEM}(x_{eq})]$$

$$M_{Z\_aft\_SF} = M_{Z\_fore\_SF} = \frac{(x_{fore} - x_{aft})}{2} [Q_{H\_T}(x_{eq}) - Q_{H\_FEM}(x_{eq})]$$

In order to control the bending moments at the target locations, another two sets of enforced moments are applied at both ends of the model. These moments are calculated by following formulae:

$$M_{Y\_aft\_BM} = -M_{Y\_fore\_BM} = - \left[ M_{V\_T}(x_{eq}) - M_{V\_FEM}(x_{eq}) - M_{Y\_aft\_SF} \left( 2 \frac{x_{eq} - x_{aft}}{x_{fore} - x_{aft}} - 1 \right) \right]$$

$$M_{Z\_aft\_BM} = -M_{Z\_fore\_BM} = - \left[ M_{H\_T}(x_{eq}) - M_{H\_FEM}(x_{eq}) - M_{Z\_aft\_SF} \left( 2 \frac{x_{eq} - x_{aft}}{x_{fore} - x_{aft}} - 1 \right) \right]$$

where:

$x_{eq}$  Considered location for the hull girder loads evaluation,

$Q_{V\_FEM}$ ,  $Q_{H\_FEM}$ ,  $M_{V\_FEM}$ ,  $M_{H\_FEM}$ : As defined in [2.5.4]

$Q_{V\_T}$ ,  $Q_{H\_T}$ ,  $M_{V\_T}$ ,  $M_{H\_T}$ : Target vertical and horizontal shear forces and bending moments, defined in Table 3 or Table 4, at the location  $x_{eq}$ . Sign of  $Q_{V\_T}$ ,  $M_{V\_T}$  and  $M_{H\_T}$  is in accordance with sign convention defined in Ch 4, Sec 3.

$M_{Y\_aft\_SF}$ ,  $M_{Y\_fore\_SF}$ ,  $M_{Y\_aft\_BM}$ ,  $M_{Y\_fore\_BM}$ : Enforced moments to apply at the aft and fore ends for vertical shear force and bending moment control, positive for clockwise around y-axis. The sign convention for  $M_{Y\_aft\_SF}$ ,  $M_{Y\_fore\_SF}$ ,  $M_{Y\_aft\_BM}$  and  $M_{Y\_fore\_BM}$  is that of the FE model axis. The sign convention for other bending moment, shear forces and reaction forces is in accordance with the sign convention defined in Ch 4, Sec 3.

$M_{Z\_aft\_SF}$ ,  $M_{Z\_fore\_SF}$ ,  $M_{Z\_aft\_BM}$ ,  $M_{Z\_fore\_BM}$ : Enforced moments to apply at the aft and fore ends for horizontal shear force and bending moment control, positive for clockwise around z-axis. The sign convention for  $M_{Z\_aft\_SF}$ ,  $M_{Z\_fore\_SF}$ ,  $M_{Z\_aft\_BM}$  and  $M_{Z\_fore\_BM}$  is that of the FE model axis. The sign convention for other bending moment, shear forces and reaction forces is in accordance with the sign convention defined in Ch 4, Sec 3.

The enforced moments at the model ends can be generated by one of the following methods:

- to apply distributed forces at the end section of the model, with a resulting force equal to zero and a resulting moment equal to the enforced moment. The distributed forces are applied to the nodes on the longitudinal members where boundary conditions are given according to Table 1. The distributed forces are to be determined by using the thin wall beam theory
- to apply concentrated moments at the independent points defined in [2.3.1].

### 2.5.7 Superimposition method

For vertical bending moment analysis in the superimposition method, the stress obtained from the following formula is to be superimposed to the longitudinal stress of each element in longitudinal members obtained from 3D FE analysis. Vertical shear force analyses are to be in accordance with [2.5.6].

$$\sigma_{SIM} = \frac{M_{V\_T}}{I_Y / (z - N)} - \frac{M_{H\_T}}{I_Z / y}$$

where

$M_{V\_T}$ ,  $M_{H\_T}$  = Target vertical and horizontal bending moments at considering section, respectively, with corrections due to local loads, taken equal to:

$$M_{V\_T} = M_{SW} + C_{WV} \cdot M_{WV} - M_{V\_FEM}$$

$$M_{H\_T} = C_{WH} \cdot M_{WH} - M_{H\_FEM}$$

$I_Y$  = Vertical inertia of the section around horizontal neutral axis, calculated according to Ch 3, Sec 2, [3.2.1]

$I_Z$  = Horizontal inertia of the section, calculated according to Ch 3, Sec 2, [3.2.1]

$N$  = Z co-ordinate of the centre of gravity of the hull transverse section, as defined in Ch 5, Sec 1

$y$  = Y co-ordinate of the element

$z$  = Z co-ordinate of the element.

### 3 Analysis criteria

#### 3.1 General

##### 3.1.1 Assessment holds

All the primary supporting members in the mid-hold of the three-hold (1+1+1) FE model, including bulkheads, are to be evaluated in 3D FE analysis.

##### 3.1.2

The results of the structural analysis are to satisfy the criteria for yielding strength, buckling strength and deflection of primary members.

#### 3.2 Yielding strength assessment

##### 3.2.1 Reference stresses

Reference stress is Von Mises equivalent stress at centre of a plane element (shell or membrane) or axial stress of a line element (bar, beam or rod) obtained by FE analysis through considering hull girder loads according to [2.5.4] or [2.5.5].

Where the effects of openings are not considered in the FE model, the reference stresses in way of the openings are to be properly modified with adjusting shear stresses in proportion to the ratio of web height and opening height.

Where elements under assessment are smaller than the standard mesh size specified in [2.2.4] or [2.2.5], the reference stress may be obtained from the averaged stress over the elements within the standard mesh size.

##### 3.2.2 Equivalent stress

Von Mises equivalent stress is given by the following formula:

$$\sigma_{eq} = \sqrt{\sigma_x^2 - \sigma_x \sigma_y + \sigma_y^2 + 3\tau_{xy}^2}$$

$\sigma_x$ ,  $\sigma_y$  = Element normal stresses, in N/mm<sup>2</sup>

$\tau_{xy}$  = Element shear stress, in N/mm<sup>2</sup>

In superimposition method, the stress  $\sigma_{SIM}$ , defined in [2.5.7], is to be superimposed onto to longitudinal stress component.

##### 3.2.3 Allowable stress

The reference stresses in FE model that does not include orthotropic elements, as specified in [2.2.4], are not to exceed  $235/k$  N/mm<sup>2</sup>, where  $k$  is the material factor defined in Ch 3, Sec 1.

The reference stresses in FE model that includes orthotropic elements, as specified in [2.2.5], are not to exceed  $205/k$  N/mm<sup>2</sup>, where  $k$  is the material factor defined in Ch 3, Sec 1.

#### 3.3 Buckling and ultimate strength assessment

##### 3.3.1 General

Buckling and ultimate strength assessment is to be performed for the panels on primary supporting members according to Ch 6, Sec 3.

### 3.3.2 Stresses of panel

The stresses in each panel are to be obtained according to the following procedures:

- 1) when the mesh model differs from the elementary plate panel geometry, the stresses  $\sigma_x$ ,  $\sigma_y$  and  $\tau$  acting on an elementary plate panel are to be evaluated by extrapolation and/or interpolation of surrounding meshes using the elements stresses or using the displacement based method described in App 2.
- 2) stresses obtained from with superimposed or direct method have to be reduced for buckling assessment because of the Poisson effect, which is taken into consideration in both analysis methods. The correction has to be carried out after summation of stresses due to local and global loads.

When the stresses  $\sigma_x^*$  and  $\sigma_y^*$  are both compressive stresses, a stress reduction is to be made according to the following formulae:

$$\sigma_x = (\sigma_x^* - 0.3\sigma_y^*) / 0.91$$

$$\sigma_y = (\sigma_y^* - 0.3\sigma_x^*) / 0.91$$

Where compressive stress fulfils the condition  $\sigma_y^* < 0.3\sigma_x^*$ , then  $\sigma_y = 0$  and  $\sigma_x = \sigma_x^*$

Where compressive stress fulfils the condition  $\sigma_x^* < 0.3\sigma_y^*$ , then  $\sigma_x = 0$  and  $\sigma_y = \sigma_y^*$

$\sigma_x^*$ ,  $\sigma_y^*$  = Stresses containing the Poisson effect

- 3) determine stress distributions along edges of the considered buckling panel by introducing proper linear approximation as shown in Fig 2.
- 4) calculate edge factor according to Ch 6, Sec 3.

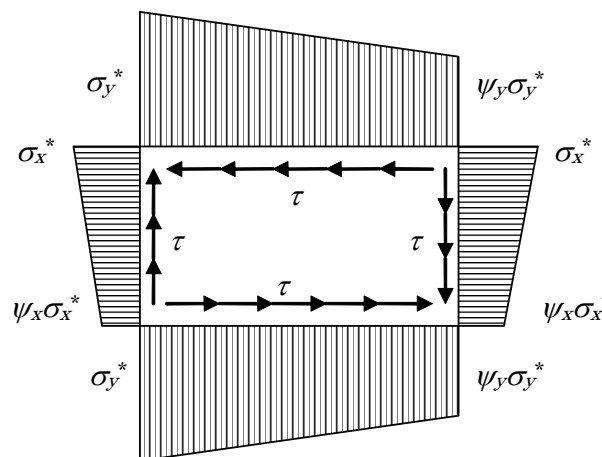

Fig. 2  
Stresses of panel for buckling assessment

### 3.3.3 Boundary conditions

Buckling load cases 1, 2, 5 or 6 of Ch 6, Sec 3, Table 2 are to be applied to the buckling panel under evaluation, depending on the stress distribution and geometry of openings.

If the actual boundary conditions are significantly different from simple support condition, another case in Ch 6, Sec 3, Table 2 can be applied.

### 3.3.4 Safety factor

The safety factor for the buckling and ultimate strength assessment of the plate is to be taken equal to 1.0.

### 3.4 Deflection of primary supporting members

The relative deflection,  $\delta_{max}$  in mm, in the outer bottom plate obtained by FEA is not to exceed the following criteria:

$$\delta_{max} \leq \frac{\ell_i}{150}$$

where:

$\delta_{max}$  Maximum relative deflection, in mm, obtained by the following formula, and not including secondary

deflection

$$\delta_{\max} = \max(|\delta_{B1}|, |\delta_{B2}|)$$

where,  $\delta_{B1}$  and  $\delta_{B2}$  are shown in Fig 3.

$l_i$  Length or breadth of the flat part of the double bottom, in mm, whichever is the shorter.

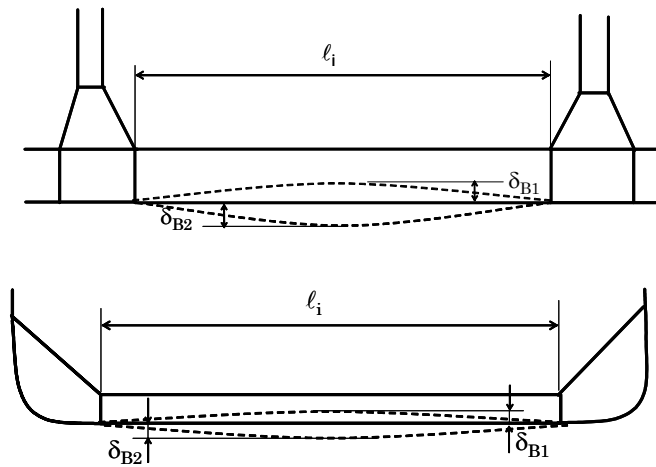

**Fig. 3**  
**Definition of relative deflection**

## **SECTION 3**

### **DETAILED STRESS ASSESSMENT**

#### **1 General**

##### **1.1 Application**

###### **1.1.1**

This Section describes the procedure for the detailed stress assessment with refined meshes to evaluate highly stressed areas of primary supporting members.

Where the global cargo hold analysis of Sec 2 is carried out using a model complying with the modelling criteria of Sec 2, [2.2.4], the areas listed in Table 1 are to be refined at the locations whose calculated stresses exceed 95% for non-orthotropic elements or 85% for orthotropic element but do not exceed 100% of the allowable stress as specified in Sec 2, [3.2.3].

#### **2 Analysis model**

##### **2.1 Areas to be refined**

###### **2.1.1**

Where the global cargo hold analysis of Sec 2 is carried out using a model complying with the modeling criteria of Sec 2, [2.2.4], the areas listed in Table 1 are to be refined at the locations whose calculated stresses exceed 95% of the allowable stress as specified in Sec 2, [3.2.3].

###### **2.1.2**

Where the global cargo hold analysis of Sec 2 is carried out using a model complying with the modeling criteria of Sec 2, [2.2.5], all the high stressed areas listed below are to be refined:

- areas whose calculated stresses exceed 85% of the allowable stress as specified in Sec 2, [3.2.3].
- typical details of the primary supporting members as shown in Table 1.
- typical details of the transverse bulkheads of the considered hold as shown in Table 1.

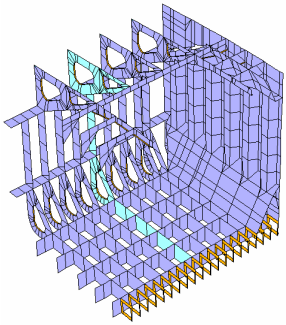
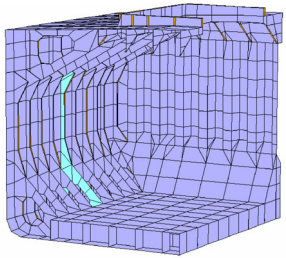
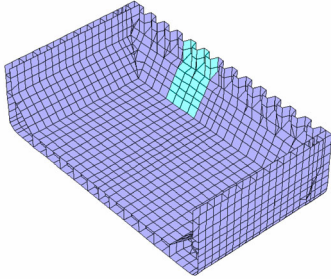
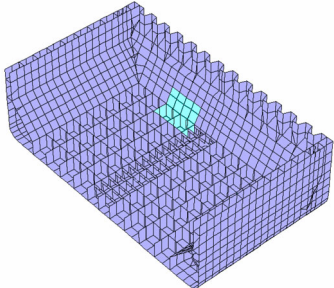
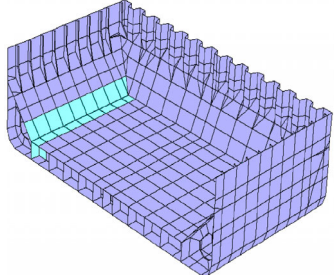
<b>Table 1 Typical details to be refined</b>			
<i>Structural member</i>	<i>Area of interest</i>	<i>Additional specifications</i>	<i>Description</i>
Primary supporting member	Most stressed transverse primary supporting member for double skin side bulk carriers	Refining of the most stressed transverse primary supporting members located in: — double bottom — hopper tank — double skin side — topside tank	
	Most stressed transverse primary supporting member for single skin side bulk carriers	Refining of the most stressed transverse primary supporting members located in: — double bottom — hopper tank — topside tank  side shell frame with end brackets and connections to hopper tank and topside tank	
Transverse bulkhead and its associated lower stool	Most stressed connection of the corrugations with the lower stool	High stressed elements, including the diaphragm(s) of the lower stool, are to be modeled	
	Most stressed connection of the lower stool with the inner bottom	High stressed elements are to be modeled	
Inner bottom and hopper sloping plates with their associated supporting members	Most stressed connection of the inner bottom with the hopper sloping plate	Refining of the most stressed following members: — inner bottom — hopper sloping plate — floor — girder	

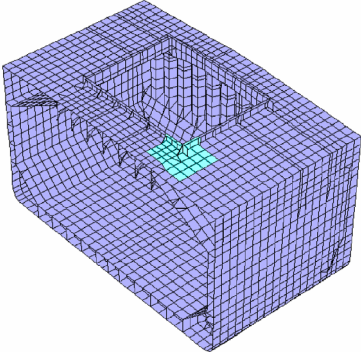

Deck plating	Deck plating in way of the most stressed hatch corners	High stressed elements are to be modeled	
--------------	--	--	---

## 2.2 Refining method

### 2.2.1

Two methods can be used for refining the high stressed areas:

- refined areas can be directly included in FE model used for the global cargo hold analysis of Ch 7, Sec 2 (See Fig 1).
- detailed stresses in refined areas can be analysed by separate sub-models.

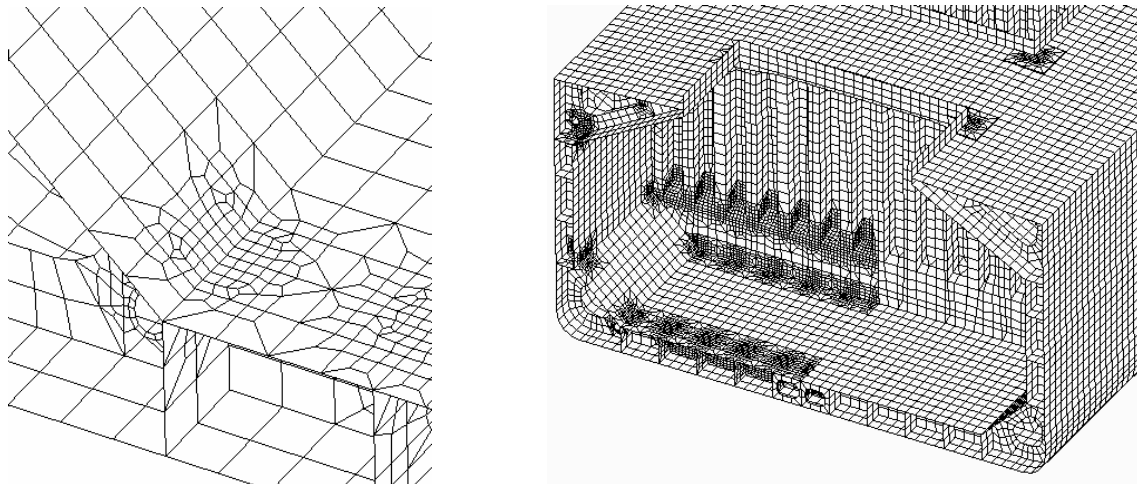

Fig. 1  
“Direct” modelling with refined meshes

## 2.3 Modeling

### 2.3.1 Element type

Each structural members is to be modeled by using proper element type for the structure in accordance with the principle in Sec 2, [2.2.3]. Orthotropic elements are not to be used in refined areas.

### 2.3.2 Mesh

The element size in refined areas is to be approximately one fourth of the representative spacing of ordinary stiffeners in the corresponding area, i.e.  $200 \times 200$  mm mesh size for structures whose ordinary stiffener spacing is 800 mm.

In addition, the web height of primary supporting members and web frames of single side bulk carriers is to be divided at least into 3 elements.

The aspect ratio of element is not to exceed 3. Quad elements are to have  $90^\circ$  angles as much as practicable, or to have angles between  $45^\circ$  and  $135^\circ$ .

### 2.3.3 Extent of sub-model

The minimum extent of sub-model is to be such that the boundaries of the sub-model correspond to the locations of adjacent supporting members (see Fig 2).

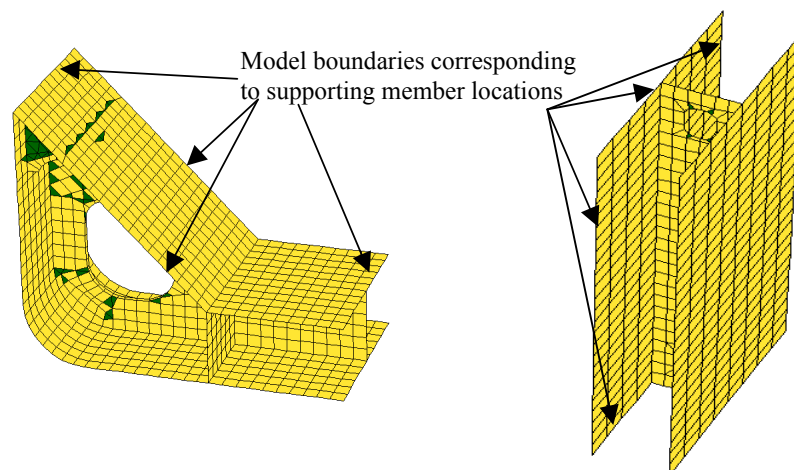

**Fig. 2**  
**Boundaries of sub-models**

## **2.4 Loading conditions**

### **2.4.1**

Loading conditions, which are applied to 3D FE model for the global cargo hold analysis according to Sec 2 and which induce stresses at considered locations exceeding the criteria specified in [2.1], are to be considered in the detailed stress assessment.

## **2.5 Boundary conditions**

### **2.5.1**

Boundary conditions as specified in Sec 2, [2.3.1] are to be applied to the global cargo hold FE model with refined meshes.

### **2.5.2**

Nodal forces or nodal displacements obtained from the global cargo hold analysis of Sec 2 are to be applied to the sub-models. Where nodal forces are given, the supporting members located at the boundaries of a sub-model are to be included in the sub-model. Where nodal displacements are given and additional nodes are provided in sub-models, nodal displacements at the additional nodes are to be determined by proper interpolations.

## **3 Analysis criteria**

### **3.1 Allowable stress**

#### **3.1.1**

Von Mises equivalent stresses in plate elements and axial stresses in line elements within refined areas are not to exceed  $280/k \text{ N/mm}^2$ , where  $k$  is the material factor defined in Ch 3, Sec 1.

In case elements significantly smaller than the size defined in [2.3.2] are used, this criteria applies to the average stress of all elements included in an area corresponding to a single element having the size specified in [2.3.2].

## **SECTION 4**

# **HOT SPOT STRESS ANALYSIS FOR FATIGUE STRENGTH ASSESSMENT**

## **1 General**

### **1.1 Application**

#### **1.1.1**

This Section describes the procedure to compute hot spot stresses for fatigue strength assessment of each location specified in Ch 8, Sec 1, Table 1 by using finite element method.

#### **1.1.2**

The loading conditions and the load cases specified in [2.2] are to be considered for hot spot stress analysis.

## **2 Analysis model**

### **2.1 Modeling**

#### **2.1.1**

Hot spot stresses for fatigue assessment are to be obtained by the global cargo hold models where the areas for fatigue assessment are modeled by very fine meshes, as shown in Fig 1.

Alternatively, hot spot stresses can be obtained from sub-models, by using the similar procedures specified in Sec 3, [2].

#### **2.1.2**

Areas within at least a quarter of frame spacing in all directions from the hot spot position are to be modeled by very fine meshes. The element size in very fine mesh areas is to be approximately equal to the representative net thickness in the assessed areas, and the aspect ratio of elements is to be close to 1.

#### **2.1.3**

The mesh size is to be gradually changed from very fine mesh to fine mesh through the transition areas as shown in Fig 2. All structural members, including brackets, stiffeners, longitudinals and faces of transverse rings, etc., within transition areas are to be modeled by shell elements with bending and membrane properties. Geometries of welds are not to be modeled.

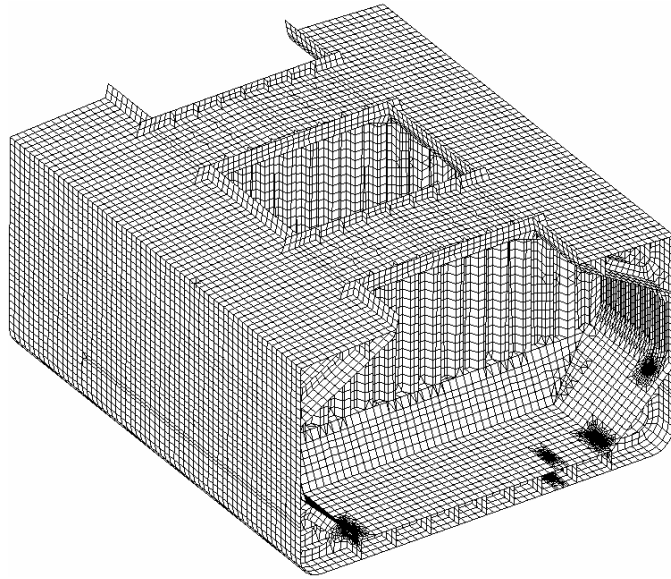

**(a) Part of global cargo hold model with very fine mesh**

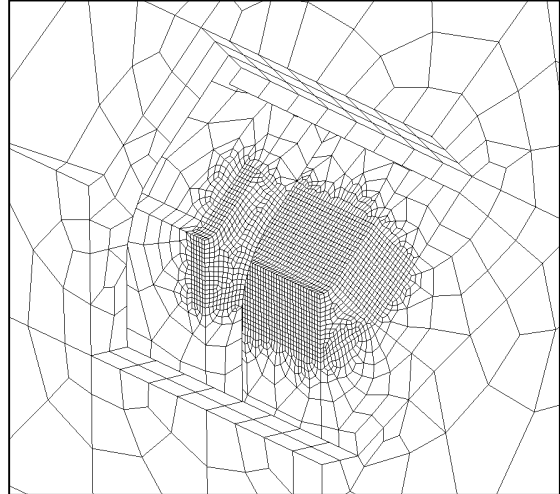
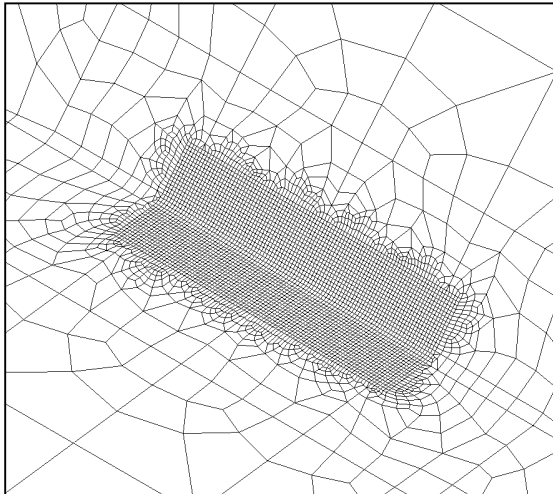

**(b) Bilge hopper knuckle part**

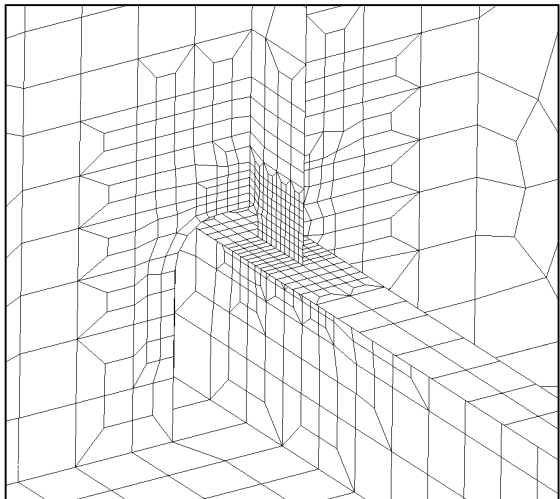
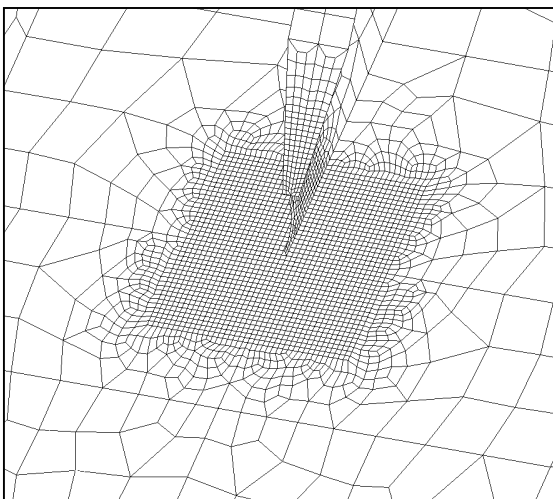

**(c) End of hold frame**

**(d) Longitudinal**

**Fig. 1**

### Example of very fine mesh model

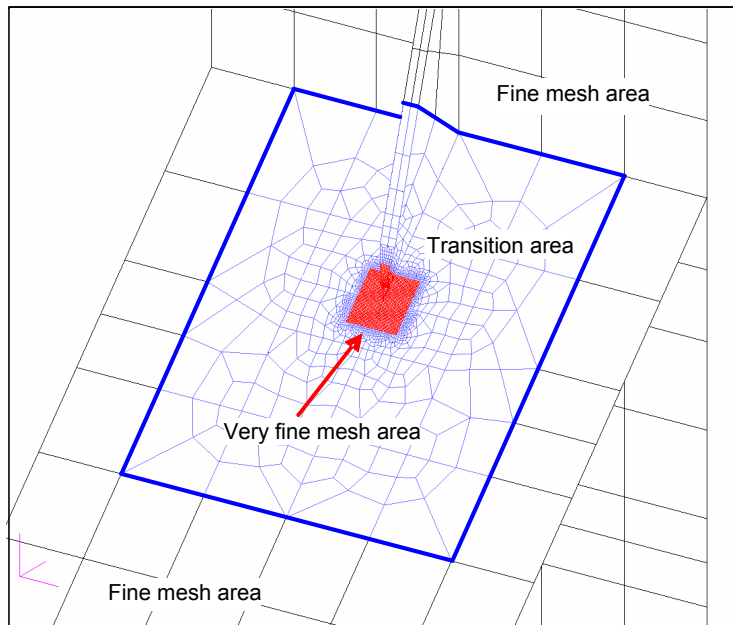

**Fig. 2**  
Very fine mesh area, transition area and fine mesh area

## 2.2 Loading conditions

### 2.2.1

The loading conditions, specified in Ch 8, Sec 1, Table 2 and illustrated in Ch 4, App 3, are to be considered.

### 2.2.2

Probability level of  $10^{-4}$  is to be used for calculation of design loads.

## 2.3 Boundary conditions

### 2.3.1

The boundary conditions specified in Sec 2, [2.3.1] are to be applied to the cargo hold model with localized very fine meshes or the mother model for sub-models. When using sub-models, nodal displacements or forces obtained from the mother model are to be applied to sub-models.

## 3 Hot spot stress

### 3.1 Definition

#### 3.1.1

The hot spot stress is defined as the structural geometric stress on the surface at a hot spot.

#### 3.1.2

The hot spot stresses obtained by using superimposition method are to be modified according to Ch 8, Sec 3, [2.2] and [3.2].

### 3.2 Evaluation of hot spot stress

#### 3.2.1

The hot spot stress in a very fine mesh is to be obtained using a linear extrapolation. The surface stresses located at 0.5 times and 1.5 times the net plate thickness are to be linearly extrapolated at the hot spot location, as described in Fig 3 and Fig.4.

The principal stress at the hot spot location having an angle with the assumed fatigue crack greater than 45° is to be considered as the hot spot stress.

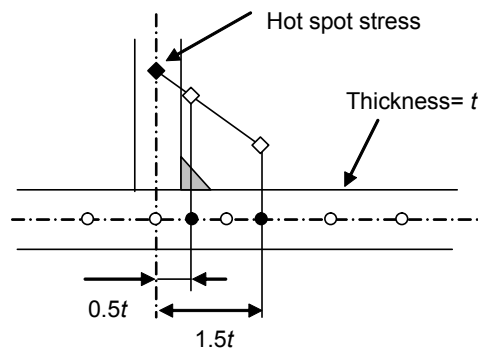

**Fig. 3**  
 Definition of hot spot stress at an intersection of two plates

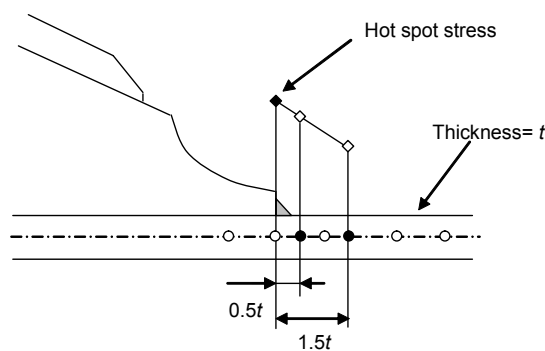

**Fig. 4**  
 Definition of hot spot stress at an intersection of plating and bracket

**3.2.2**

The hot spot stress at the intersection of two plates, as obtained from [3.2.1], is to be multiplied by the correction factor  $\lambda$  defined below, considering the difference between the actual hot spot location and assumed location and the difference of stress gradient depending on the angle  $\theta$ , in deg, between the two plates, to be measured between 0° and 90°.

— welded intersection between plane plates:

$$\lambda = \begin{cases} 0.8 & : \theta \leq 75 \\ 0.8 - \frac{0.2}{15}(\theta - 75) & : 75 < \theta \end{cases}$$

— welded intersection between bent plate and plane plate:  $\lambda = 0.7$  (i.e. bend type bilge knuckle part)

**3.2.3**

The hot spot stress in a non-welded area or along free edge is to be determined by extrapolating the principal stresses of the two adjacent elements, as shown in Fig 5.

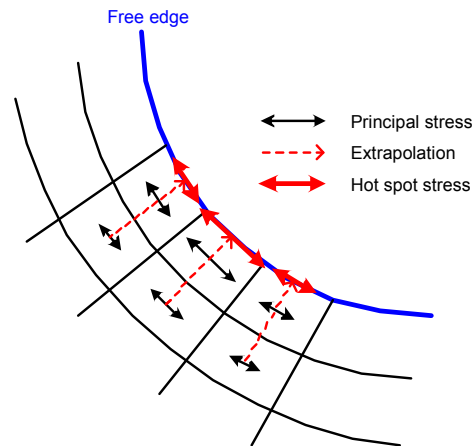

**Fig. 5**  
Definition of the hot spot stress along free edge

### 3.3 Simplified method for the bilge hopper knuckle part

#### 3.3.1

At the bilge knuckle part, the hot spot stress  $\sigma_{hotspot}$  may be computed by multiplying the nominal stress  $\sigma_{nominal}$  with the stress concentration factor  $K_{gl}$  defined in [3.3.3].

$$\sigma_{hotspot} = K_{gl} \sigma_{nominal}$$

#### 3.3.2

The nominal stress at the hot spot location is to be determined by extrapolating the membrane stresses located at 1.5 times and 2.5 times the frame spacing from the hot spot location, as shown in Fig 6.

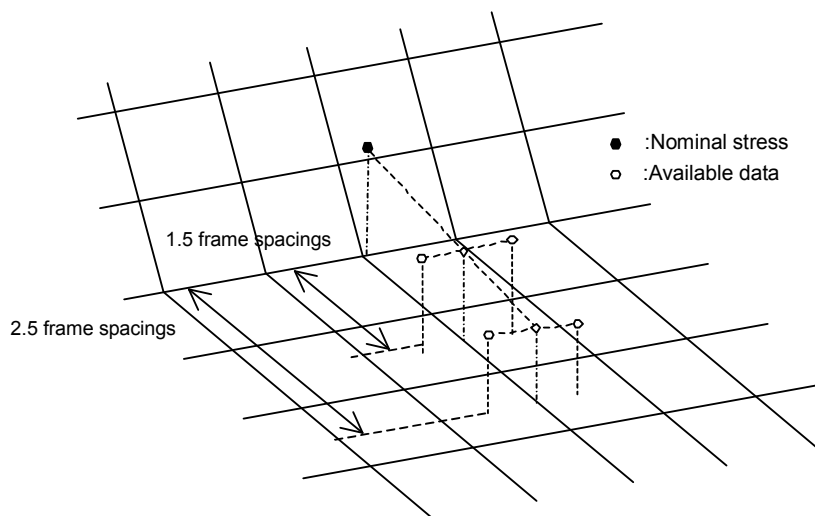

**Fig. 6**  
Definition of nominal stress at the bilge hopper knuckle part

#### 3.3.3

The geometrical stress concentration factor  $K_{gl}$  for the bilge hopper knuckle part is given by the following equation:

$$K_{gl} = K_0 K_1 K_2 K_3 K_4$$

where:

- $K_0$  = Stress concentration factor depending on the dimensions of the considered structure, defined in Table 1
- $K_1$  = Correction coefficient depending on the type of knuckle connection, defined in Table 2
- $K_2$  = Correction coefficient depending on the thickness increment of the transverse web, defined in Table 2 or taken equal to 1.0 if there is no thickness increment
- $K_3$  = Correction coefficient depending on the insertion of horizontal gusset or longitudinal rib (see Fig 7),

defined in Table 2 or taken equal to 1.0 if there is no horizontal gusset or longitudinal rib  
 $K_4$  = Correction coefficient depending on the insertion of transverse rib, defined in Table 2 (see Fig 8) or taken equal to 1.0 if there is no transverse rib

Plate net thickness in FE model $t$ (mm)	Angle of hopper slope plate to the horizontal $\theta$ (deg.)			
	40	45	50	90
16	3.0	3.2	3.4	4.2
18	2.9	3.1	3.3	4.0
20	2.8	3.0	3.2	3.8
22	2.7	2.9	3.1	3.6
24	2.6	2.8	3.0	3.5
26	2.6	2.7	2.9	3.4
28	2.5	2.7	2.8	3.3
30	2.4	2.6	2.7	3.2

Note: Alternatively,  $K_0$  can be determined by the following formula.

$$K_0 = \frac{0.14\theta \cdot (1.15 - 0.0033\theta)}{(0.5t)^{(0.2+0.0028\theta)}}$$

Type of knuckle	$K_1$	$K_2$	$K_3$	$K_4$
Weld Type	1.7	0.9	0.9	0.9
Bend Type	1.75 ; $R/t < 4$ 2.80 ; $R/t > 8$		0.85 ; $R/t < 4$ 0.55 ; $R/t > 8$	

Notes :

- 1) The linear interpolation is applied between  $4 \leq R/t \leq 8$   
 "R" denotes the radius of bend part and "t" denotes the plate thickness
- 2) In using the correction coefficient  $K_2$ , the members should be arranged such that the bending deformation of the radius part is effectively suppressed.
- 3) The increase in web thickness is taken based on the plate thickness of the inner bottom plating.



**Fig. 7**  
 Example of insertion of horizontal gusset or longitudinal rib

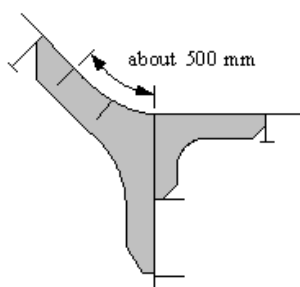

**Fig. 8**  
 Example of insertion of transverse rib



## APPENDIX 1 LONGITUDINAL EXTENT OF THE FINITE ELEMENT MODELS

### 1 Longitudinal extent

#### 1.1

A three-hold length finite element model is recommended for the analysis, with the mid-hold as the target of assessment.

The three-hold length finite element model reduces the adverse effects of the boundary conditions to a minimum in the assessed mid-hold.

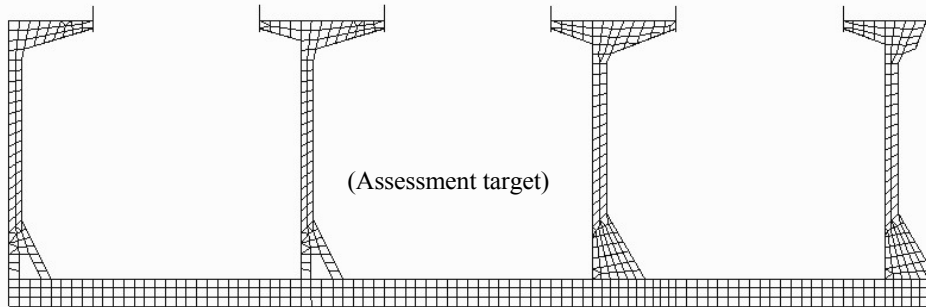

**Fig. 1**  
Longitudinal extent of the finite element model

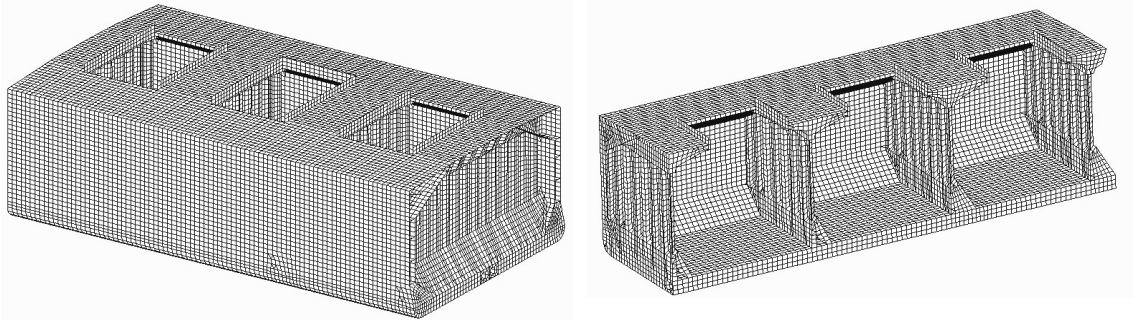

**Fig. 2**  
Example of a finite element model

## 2 Typical Mesh

### 2.1

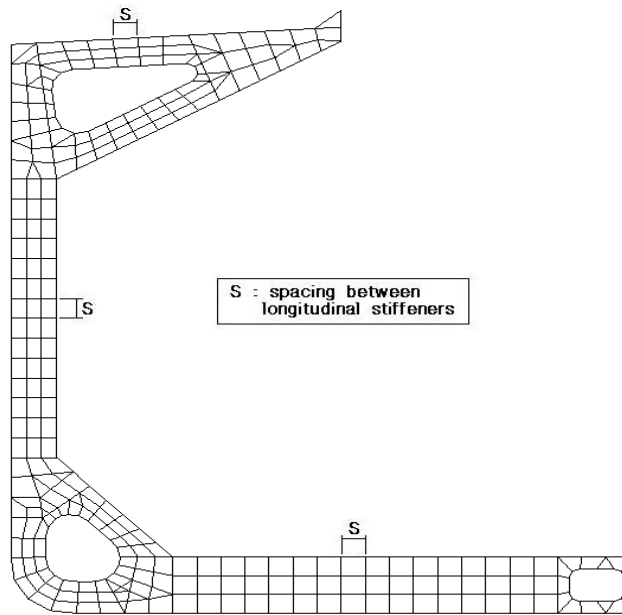

**Fig. 3**  
Typical mesh of a web frame

## APPENDIX 2

# DISPLACEMENT BASED BUCKLING ASSESSMENT IN FINITE ELEMENT ANALYSIS

### Symbols

For symbols not defined in this section, refer to Ch 1, Sec 4.

- $a$  = Length of the longer plate panel side  
 $b$  = Length of the shorter plate panel side  
 $x$  = Direction parallel to  $a$ , taken as the longitudinal direction  
 $y$  = Direction parallel to  $b$ , taken as the transverse direction  
 $C$  = Coefficient taken equal to:  
     for 4-node buckling panel:  $C = \frac{E}{2(1-\nu^2)}$   
     for 8-node buckling panel:  $C = \frac{E}{4(1-\nu^2)}$   
 $\nu$  = Poisson ratio  
 $m$  = Coefficient taken equal to:  $m = 1 - \nu$

## 1 Introduction

### 1.1

#### 1.1.1

This appendix provides a method to obtain the buckling stresses and edge stress ratios for elementary plate panels (EPP) from a finite element calculation. this method is called “displacement method”.

## 2 Displacement Method

### 2.1 General

#### 2.1.1

As the mesh of the finite elements does not correspond, in general, to the buckling panels the nodal points of the EPP can be mapped onto the FE-mesh and the displacements of these nodes can be derived from the FE-calculation.

Whenever operations on displacements are performed, full numerical accuracy of the displacements should be used.

#### 2.1.2 4-node and 8-node panels

When the aspect ratio of the EPP is less than 3 and the variation of the longitudinal stresses in longitudinal direction of the EPP is small, a 4-node panel may be used. otherwise an 8-node panel is to be taken.

#### 2.1.3 Calculation of nodal displacements

three different node locations are possible:

- If a node of the buckling panel is located at an FE-node, then the displacements can be transferred directly.
- If a node of the buckling panel is located on the edge of a plane stress element, then the displacements can be linearly interpolated between the FE-nodes at the edge.
- If a node of the buckling panel is located inside of an element, then the displacements can be obtained using bi-linear interpolation of all nodes of the element.

#### 2.1.4 Transformation in local system

The transformation of the nodal displacements from the global FE-system into the local system of the buckling panel is performed by:

$$(u) = [\lambda] \cdot (u_g)$$

Where:

$(u)$  = Local displacement vector

$(u_g)$  = Global displacement vector

$[\lambda]$  = Transformation matrix (2x3), of direction cosines of angles formed between the two sets of axes.

## 2.2 Calculation of buckling stresses and edge stress ratios

### 2.2.1

The displacements, derived at the corners of the elementary plate panel, are to be considered as input from which the stresses at certain stress-points are derived. In the 4-node buckling panel these points are identical but in the 8-node buckling panel they differ. The locations and the numbering convention may be taken from Fig 1 and Fig 2.

The derived stresses at epp corner nodes can be directly used as input for the buckling assessment according Ch 6, Sec 3. The buckling load cases, which have to be considered in the fem buckling assessment and defined in Ch 7 are buckling load cases 1, 2 and 5 of Ch 6, Sec 3, Table 2 and 1a, 1b, 2 and 4 of Ch 6, Sec 3, Table 3. in special cases, other buckling load cases may be used for the buckling assessment by a hand calculation.

### 2.2.2 4-node buckling panel

Stress displacement relationship for a 4-node buckling panel (compressive stresses are positive)

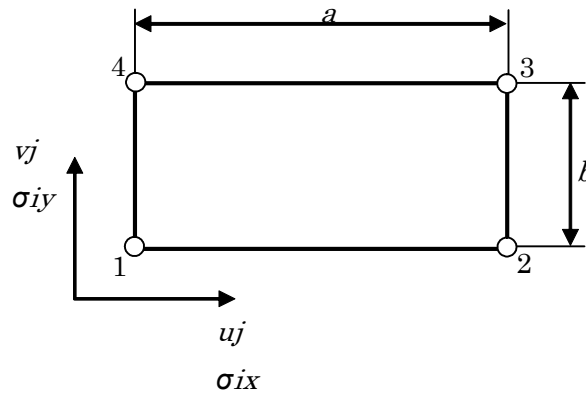

Fig. 1  
4-node buckling panel

From the displacements of the EPP corner nodes the stresses of these nodes can be obtained using

$$\begin{pmatrix} \sigma_{1x}^* \\ \sigma_{1y}^* \\ \tau_1 \\ \sigma_{2x}^* \\ \sigma_{2y}^* \\ \tau_2 \\ \sigma_{3x}^* \\ \sigma_{3y}^* \\ \tau_3 \\ \sigma_{4x}^* \\ \sigma_{4y}^* \\ \tau_4 \end{pmatrix} = -C \cdot \begin{pmatrix} -2/a & -2v/b & 2/a & 0 & 0 & 0 & 0 & 2v/b \\ -2v/a & -2/b & 2v/a & 0 & 0 & 0 & 0 & 2/b \\ -m/b & -m/a & 0 & m/a & 0 & 0 & m/b & 0 \\ -2/a & 0 & 2/a & -2v/b & 0 & 2v/b & 0 & 0 \\ -2v/a & 0 & 2v/a & -2/b & 0 & 2/b & 0 & 0 \\ 0 & -m/a & -m/b & m/a & m/b & 0 & 0 & 0 \\ 0 & 0 & 0 & -2v/b & 2/a & 2v/b & -2/a & 0 \\ 0 & 0 & 0 & -2/b & 2v/a & 2/b & -2v/a & 0 \\ 0 & 0 & -m/b & 0 & m/b & m/a & 0 & -m/a \\ 0 & -2v/b & 0 & 0 & 2/a & 0 & -2/a & 2v/b \\ 0 & -2/b & 0 & 0 & 2v/a & 0 & -2v/a & 2/b \\ -m/b & 0 & 0 & 0 & 0 & m/a & m/b & -m/a \end{pmatrix} \begin{pmatrix} u_1 \\ v_1 \\ u_2 \\ v_2 \\ u_3 \\ v_3 \\ u_4 \\ v_4 \end{pmatrix}$$

Where:

$(\sigma_{1x}^*, \sigma_{1y}^*, \tau_1, \dots, \sigma_{4x}^*, \sigma_{4y}^*, \tau_4)^T = (\sigma^*)$ : Element stress vector

$(u_1, v_1, \dots, u_4, v_4)^T = (u)$ : Local node displacement vector

If both  $\sigma_x^*$  and  $\sigma_y^*$  are compressive stresses then the stresses  $\sigma_x$  and  $\sigma_y$  must be obtained as follows:

$$\sigma_x = (\sigma_x^* - 0.3\sigma_y^*) / 0.91$$

$$\sigma_y = (\sigma_y^* - 0.3\sigma_x^*) / 0.91$$

Where compressive stress fulfils the condition  $\sigma_y^* < 0.3\sigma_x^*$ , then  $\sigma_y = 0$  and  $\sigma_x = \sigma_x^*$

Where compressive stress fulfils the condition  $\sigma_x^* < 0.3\sigma_y^*$ , then  $\sigma_x = 0$  and  $\sigma_y = \sigma_y^*$

This leads to the following stress vector:

$$(\sigma) = (\sigma_{1x}, \sigma_{1y}, \tau_1, \dots, \sigma_{4x}, \sigma_{4y}, \tau_4)^T$$

Finally the relevant buckling stresses and edge stress ratios are obtained by:

— LC 1: Longitudinal compression

$$\sigma_l = \max\left(\frac{\sigma_{1x} + \sigma_{4x}}{2}, \frac{\sigma_{2x} + \sigma_{3x}}{2}\right)$$

$$\Delta\sigma_l = \frac{1}{2}(-\sigma_{1x} + \sigma_{4x} - \sigma_{2x} + \sigma_{3x})$$

$$\sigma_x = \sigma_l + 0.5|\Delta\sigma_l|$$

$$\psi_x = 1 - |\Delta\sigma_l| / \sigma_x$$

— LC 2: Transverse compression

$$\sigma_t = 0.25 \sum_{i=1}^4 \sigma_{iy}$$

$$\Delta\sigma_t = \frac{1}{2}(-\sigma_{1y} - \sigma_{4y} + \sigma_{2y} + \sigma_{3y})$$

$$\sigma_y = \sigma_t + 0.5|\Delta\sigma_t|$$

$$\psi_y = 1 - |\Delta\sigma_t| / \sigma_y$$

— LC 5: Shear

$$\tau = \left| \frac{\tau_1 + \tau_2 + \tau_3 + \tau_4}{4} \right|$$

### 2.2.3 8-node buckling panel

Stress displacement relationship for a 8-node buckling panel (compressive stresses are positive)

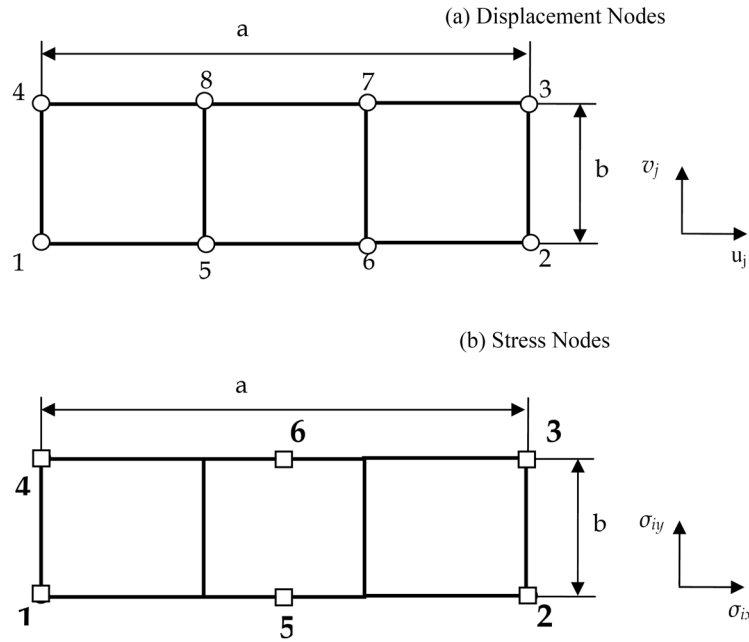

**Fig. 2**  
**8-node buckling panel**

From the displacements of the EPP corner nodes the stresses of these nodes and on mid positions can be obtained using:

$$\begin{pmatrix} \sigma_{1x}^* \\ \sigma_{1y}^* \\ \tau_1 \\ \sigma_{2x}^* \\ \sigma_{2y}^* \\ \tau_2 \\ \sigma_{3x}^* \\ \sigma_{3y}^* \\ \tau_3 \\ \sigma_{4x}^* \\ \sigma_{4y}^* \\ \tau_4 \\ \sigma_{5x}^* \\ \sigma_{5y}^* \\ \tau_5 \\ \sigma_{6x}^* \\ \sigma_{6y}^* \\ \tau_6 \end{pmatrix} = -C \cdot \begin{pmatrix} -12/a & -4v/b & 0 & 0 & 0 & 0 & 0 & 4v/b & 12/a & 0 & 0 & 0 & 0 & 0 & 0 & 0 \\ -12v/a & -4/b & 0 & 0 & 0 & 0 & 0 & 4/b & 12v/a & 0 & 0 & 0 & 0 & 0 & 0 & 0 \\ -2m/b & -6m/a & 0 & 0 & 0 & 0 & 2m/b & 0 & 0 & 6m/a & 0 & 0 & 0 & 0 & 0 & 0 \\ 0 & 0 & 12/a & -4v/b & 0 & 4v/b & 0 & 0 & 0 & 0 & -12/a & 0 & 0 & 0 & 0 & 0 \\ 0 & 0 & 12v/a & -4/b & 0 & 4/b & 0 & 0 & 0 & 0 & -12v/a & 0 & 0 & 0 & 0 & 0 \\ 0 & 0 & -2m/b & 6m/a & 2m/b & 0 & 0 & 0 & 0 & 0 & 0 & -6m/a & 0 & 0 & 0 & 0 \\ 0 & 0 & 0 & -4v/b & 12/a & 4v/b & 0 & 0 & 0 & 0 & 0 & -12/a & 0 & 0 & 0 & 0 \\ 0 & 0 & 0 & -4/b & 12v/a & 4/b & 0 & 0 & 0 & 0 & 0 & -12v/a & 0 & 0 & 0 & 0 \\ 0 & 0 & -2m/b & 0 & 2m/b & 6m/a & 0 & 0 & 0 & 0 & 0 & 0 & -6m/a & 0 & 0 & 0 \\ 0 & -4v/b & 0 & 0 & 0 & 0 & -12/a & 4v/b & 0 & 0 & 0 & 0 & 0 & 0 & 12/a & 0 \\ 0 & -4/b & 0 & 0 & 0 & 0 & -12v/a & 4/b & 0 & 0 & 0 & 0 & 0 & 0 & 12v/a & 0 \\ -2m/b & 0 & 0 & 0 & 0 & 0 & 2m/b & -6m/a & 0 & 0 & 0 & 0 & 0 & 0 & 0 & 6m/a \\ 0 & 0 & 0 & 0 & 0 & 0 & 0 & 0 & -12/a & -2v/b & 12/a & -2v/b & 0 & 2v/b & 0 & 2v/b \\ 0 & 0 & 0 & 0 & 0 & 0 & 0 & 0 & -12v/a & -2/b & 12v/a & -2/b & 0 & 2/b & 0 & 2/b \\ 0 & 0 & 0 & 0 & 0 & 0 & 0 & 0 & -m/b & -6m/a & -m/b & 6m/a & m/b & 0 & m/b & 0 \\ 0 & 0 & 0 & 0 & 0 & 0 & 0 & 0 & 0 & -2v/b & 0 & -2v/b & 12/a & 2v/b & -12/a & 2v/b \\ 0 & 0 & 0 & 0 & 0 & 0 & 0 & 0 & 0 & -2/b & 0 & -2/b & 12v/a & 2/b & -12v/a & 2/b \\ 0 & 0 & 0 & 0 & 0 & 0 & 0 & 0 & -m/b & 0 & -m/b & 0 & m/b & 6m/a & m/b & -6m/a \end{pmatrix} \begin{pmatrix} u_1 \\ v_1 \\ u_2 \\ v_2 \\ u_3 \\ v_3 \\ u_4 \\ v_4 \\ u_5 \\ v_5 \\ u_6 \\ v_6 \\ u_7 \\ v_7 \\ u_8 \\ v_8 \end{pmatrix}$$

Where:

$$(\sigma^*) = (\sigma_{1x}^*, \sigma_{1y}^*, \tau_1, \dots, \sigma_{6x}^*, \sigma_{6y}^*, \tau_6)^T$$

$$(u) = (u_{1x}, v_{1y}, \dots, u_{8x}, v_{8y})^T$$

If both  $\sigma_x^*$  and  $\sigma_y^*$  are compressive stresses then the stresses  $\sigma_x$  and  $\sigma_y$  must be obtained as follows:

$$\sigma_x = (\sigma_x^* - 0.3 \cdot \sigma_y^*) / 0.91$$

$$\sigma_y = (\sigma_y^* - 0.3 \cdot \sigma_x^*) / 0.91$$

Where compressive stress fulfils the condition  $\sigma_y^* < 0.3 \sigma_x^*$ , then  $\sigma_y = 0$  and  $\sigma_x = \sigma_x^*$

Where compressive stress fulfils the condition  $\sigma_x^* < 0.3 \sigma_y^*$ , then  $\sigma_x = 0$  and  $\sigma_y = \sigma_y^*$

This leads to the following stress vector:

$$(\sigma) = (\sigma_{1x}, \sigma_{1y}, \tau_1, \dots, \sigma_{6x}, \sigma_{6y}, \tau_6)^T$$

The relevant buckling stresses can be obtained by:

— LC 1: Longitudinal compression

$$\sigma_l = \max\left(\frac{\sigma_{1x} + \sigma_{4x}}{2}, \frac{\sigma_{6x} + \sigma_{5x}}{2}, \frac{\sigma_{2x} + \sigma_{3x}}{2}\right)$$

$$\Delta\sigma_l = \frac{1}{3}(\sigma_{4x} - \sigma_{1x} - \sigma_{5x} + \sigma_{6x} + \sigma_{3x} - \sigma_{2x})$$

$$\sigma_x = \sigma_l + 0.5|\Delta\sigma_l|$$

$$\psi_x = 1 - |\Delta\sigma_l|/\sigma_x$$

— LC 2: Transverse compression

$$\sigma_t = \frac{1}{6} \sum_{i=1}^6 \sigma_{iy}$$

$$\Delta\sigma_t = \frac{1}{2}(-\sigma_{1y} - \sigma_{4y} + \sigma_{2y} + \sigma_{3y})$$

$$\sigma_y = \sigma_t + 0.5|\Delta\sigma_t|$$

$$\psi_y = 1 - |\Delta\sigma_t|/\sigma_y$$

— LC 5: Shear

$$\tau = \text{Max}\left\{\left|\frac{\tau_1 + \tau_4 + \tau_5 + \tau_6}{4}\right|, \left|\frac{\tau_2 + \tau_3 + \tau_5 + \tau_6}{4}\right|\right\}$$





# **Chapter 8**

## **Fatigue Check of Structural Details**

---

Section 1 General Consideration

Section 2 Fatigue Strength Assessment

Section 3 Stress Assessment of Primary Members

Section 4 Stress Assessment of Stiffeners

Section 5 Stress Assessment of Hatch Corners

Appendix 1 Cross Sectional Properties for Torsion



## SECTION 1 GENERAL CONSIDERATION

### 1 General

#### 1.1 Application

##### 1.1.1

The requirements of this Chapter are to be applied to ships having length  $L$  of 150 m or above, with respect to 25 years operation life in North Atlantic.

##### 1.1.2

The requirements of this Chapter apply to fatigue cycles induced by wave loads. Fatigue induced by vibrations, low cycle loads or impact loads such as slamming, is out of the scope of this Chapter.

##### 1.1.3

The requirements of this Chapter are applicable where steel materials have a minimum yield stress less than 400 N/mm<sup>2</sup>.

#### 1.2 Net scantlings

##### 1.2.1

All scantlings and stresses referred to in this Chapter are net scantlings obtained in accordance with Ch 3, Sec 2.

#### 1.3 Subject members

##### 1.3.1

Fatigue strength is to be assessed, in cargo hold area, for members described in Table 1, at the considered locations.

<b>Table 1 Members and locations subjected to fatigue strength assessment</b>	
<i>Members</i>	<i>Details</i>
Inner bottom plating	Connection with sloping and /or vertical plate of lower stool
	Connection with sloping plate of hopper tank
Inner side plating	Connection with sloping plate of hopper tank
Transverse bulkhead	Connection with sloping plate of lower stool
	Connection with sloping plate of upper stool
Hold frames of single side bulk carriers	Connection to the upper and lower wing tank
Ordinary stiffeners in double side space	Connection of longitudinal stiffeners with web frames and transverse bulkhead
	Connection of transverse stiffeners with stringer or similar
Ordinary stiffeners in upper and lower wing tank	Connection of longitudinal stiffeners with web frames and transverse bulkhead
Ordinary stiffeners in double bottom	Connection of longitudinal stiffeners with floors and floors in way of lower stool or transverse bulkhead
Hatch corners	Free edges of hatch corners

### 2 Definitions

#### 2.1 Hot spot

##### 2.1.1

Hot spot is the location where fatigue crack may initiate.

## 2.2 Nominal stress

### 2.2.1

Nominal stress is the stress in a structural component taking into account macro-geometric effects but disregarding the stress concentration due to structural discontinuities and to the presence of welds.

Nominal stresses are to be obtained either with the coarse mesh FE analysis specified in Ch 7, Sec 4, or with the simplified procedure specified in Sec 4.

## 2.3 Hot spot stress

### 2.3.1

Hot spot stress is defined as the local stress at the hot spot. The hot spot stress takes into account the influence of structural discontinuities due to the geometry of the connection but excludes the effects of welds.

Hot spot stresses are to be obtained either by fine mesh FE analysis specified in Ch 7, Sec 4, or by multiplying nominal stresses by stress concentration factors defined in Sec 4.

## 2.4 Notch stress

### 2.4.1

Notch stress is defined as the peak stress at the weld toe taking into account stress concentrations due to the effects of structural geometry as well as the presence of welds.

Notch stress is to be obtained by multiplying hot spot stress by fatigue notch factor defined in Sec 2, [2.3.1], Table 1.

## 3 Loading

### 3.1 Loading condition

#### 3.1.1

The loading conditions to be considered are defined in Table 2 depending on the ship type. The standard loading conditions illustrated in Ch 4, App 3 are to be considered.

<i>Ship type</i>	<i>Full load condition</i>		<i>Ballast condition</i>	
	<i>Homogeneous</i>	<i>Alternate</i>	<i>Normal ballast</i>	<i>Heavy ballast</i>
<b>BC-A</b>	✓	✓	✓	✓
<b>BC-B</b>	✓	---	✓	✓
<b>BC-C</b>	✓	---	✓	✓

### 3.2 Load case

#### 3.2.1 Load cases

For each loading condition, the load cases to be considered, defined in Ch 4, Sec 4, [2], are:

- “H1” and “H2” corresponding to the EDW “H” (head sea)
- “F1” and “F2” corresponding to the EDW “F” (following sea)
- “R1” and “R2” corresponding to the EDW “R” (beam sea)
- “P1” and “P2” corresponding to the EDW “P” (beam sea).

#### 3.2.2

In the case of fatigue assessment of hatch corners, only oblique sea is to be considered, taking into account the wave torsional moments defined in Ch 4, Sec 3, [3.4].

#### 3.2.3 Predominant load case

From the above mentioned load cases and for each loading condition, the load case where the combined stress range is maximum, corresponds to the predominant load case.

## SECTION 2 FATIGUE STRENGTH ASSESSMENT

### Symbols

For symbols not defined in this Section, refer to Ch 1, Sec 4.

- $i$  = Suffix which denotes load case “H”, “F”, “R” or “P” specified in Ch 4, Sec 4  
“ $i1$ ” denotes load case “H1”, “F1”, “R1” or “P1” and “ $i2$ ” denotes load case “H2”, “F2”, “R2” or “P2”
- $(k)$  = Suffix which denotes loading condition “homogeneous condition”, “alternate condition”, “normal ballast condition” or “heavy ballast condition” as defined in Sec 1, Table 2
- $\Delta\sigma_{W, i(k)}$  = Hot spot stress range, in N/mm<sup>2</sup>, in load case “ $i$ ” of loading condition “ $(k)$ ”
- $\sigma_{mean, i(k)}$  = Structural hot spot mean stress, in N/mm<sup>2</sup>, in load case “ $i$ ” of loading condition “ $(k)$ ”.

## 1 General

### 1.1 Application

#### 1.1.1

This Section gives the linear cumulative damage procedure for the fatigue strength assessment of this Chapter.

#### 1.1.2

Fatigue strength is assessed based on an equivalent notch stress range obtained by multiplying an equivalent hot spot stress range by a fatigue notch factor.

#### 1.1.3

Hot spot stress ranges and hot spot mean stresses of primary members, longitudinal stiffeners connections and hatch corners are to be assessed respectively by Sec 3, Sec 4 and Sec 5.

#### 1.1.4 Primary members and longitudinal stiffeners connections

Predominant load cases and ‘condition 1’ are to be obtained respectively in [2.1] and [2.2]. The hot spot stress ranges calculated in Sec 3 or Sec 4, corresponding to the predominant load case for each loading condition, are to be used in [2.3.2] to calculate the equivalent hot spot stress range.

#### 1.1.5 Hatch corners

The hot spot stress range calculated in Sec 5 is to be used in [2.3.2] to calculate the equivalent hot spot stress range.

## 2 Equivalent notch stress range

### 2.1 Predominant load case

#### 2.1.1

The predominant load case “ $I$ ” in fatigue assessment for each loading condition is the load case for which the combined stress range for the considered member is the maximum among the load cases “H”, “F”, “R” and “P” specified in Sec 1, [3.2.1].

$$\Delta\sigma_{W, I(k)} = \max_i(\Delta\sigma_{W, i(k)})$$

where:

- $\Delta\sigma_{W, i(k)}$  = Combined hot spot stress range, in N/mm<sup>2</sup>, defined either in Sec 3, [2.1.1], [2.2.1] or Sec 4, [2.3.1].
- $I$  = Suffix which denotes the selected predominant load case of loading condition “ $(k)$ ”.

## 2.2 Loading ‘condition 1’

### 2.2.1

The ‘condition 1’ is the condition in which the maximum stress calculated by the equation below for the considered member is the largest on the tension side among the loading conditions “homogeneous”, “alternate”, “normal ballast” and “heavy ballast” specified in Sec 1, Table 2.

$$\sigma_{\max,1} = \max_k \left( \sigma_{\text{mean}, I(k)} + \frac{\Delta\sigma_{W, I(k)}}{2} \right)$$

where:

- $\sigma_{\text{mean}, I(k)}$  = Structural hot spot mean stress, in N/mm<sup>2</sup>, in predominant load case of loading condition “(k)” defined in [2.1.1]  
 $\Delta\sigma_{W, I(k)}$  = Hot spot stress range, in N/mm<sup>2</sup>, in predominant load case of loading condition “(k)” defined in [2.1.1]

### 2.2.2

Further to the determination of ‘condition 1’ according to [2.2.1], the corresponding loading condition is to be indexed with the suffix “j” equal 1.

## 2.3 Equivalent notch stress range

### 2.3.1 Equivalent notch stress range

The equivalent notch stress range, in N/mm<sup>2</sup>, for each loading condition is to be calculated with the following formula:

$$\Delta\sigma_{eq, j} = K_f \Delta\sigma_{equiv, j}$$

where:

- $\Delta\sigma_{equiv, j}$  = Equivalent hot spot stress range, in N/mm<sup>2</sup>, in loading condition “j” obtained by [2.3.2].  
 $K_f$  = Fatigue notch factor defined in Table 1.

<i>Subject</i>	<i>Without weld grinding</i>	<i>With weld grinding (not applicable for ordinary stiffeners and boxing fillet welding <sup>1)</sup>)</i>
Butt welded joint	1.25	1.10
Fillet welded joint	1.30	1.15 <sup>2)</sup>
Non welded part	1.00	-

Notes:

1) Boxing fillet welding is defined as a fillet weld around a corner of a member as an extension of the principal weld.  
 2) This is applicable for deep penetration welding, or full penetration welding only.

In case where grinding is performed, full details regarding grinding standards including the extent, smoothness particulars, final welding profiles, and grinding workmanship as well as quality acceptance criteria are to be submitted to the Society for approval.

It is preferred that any grinding is carried out by rotary burrs, is to extend below plate surfaces in order to remove any toe defects and ground areas are to have sufficient corrosion protection.

Such treatments are to procedure smooth concave profiles at weld toes with the depth of these depressions penetrating into plate surfaces to at least 0.5 mm below the bottom of any visible undercuts.

The depth of any grooves produced is to be kept to a minimum and, in general, kept to a maximum of 1 mm.

Under no circumstances is grinding depth to exceed 2 mm or 7% of plate gross thickness, whichever is smaller. Grinding has to extend to 0.5 longitudinal spacing or 0.5 frame spacing at the each side of hot spot locations.

### 2.3.2 Equivalent hot spot stress range

The equivalent hot spot stress range, in N/mm<sup>2</sup>, is to be calculated for each loading condition with the following

formula:

$$\Delta\sigma_{equiv, j} = f_{mean, j} \Delta\sigma_{W, j}$$

where:

$f_{mean, j}$  = Correction factor for mean stress:

— for hatch corners  $f_{mean, j} = 0.77$

— for primary members and longitudinal stiffeners connections,  $f_{mean, j}$  corresponding to the condition “j” taken equal to:

$$f_{mean, j} = \max \left\{ 0.4, \left[ \max \left( 0, \frac{1}{2} + \frac{-\ln(10^{-4})}{4} \frac{\sigma_{m, j}}{\Delta\sigma_{W, j}} \right) \right]^{0.25} \right\}$$

$\sigma_{m, 1}$  = Local hot spot mean stress, in N/mm<sup>2</sup>, in the condition “1”, obtained from the following formulae:

— if  $0.6\Delta\sigma_{W, 1} \geq 2.5R_{eH}$

$$\sigma_{m, 1} = -0.18\Delta\sigma_{W, 1}$$

— if  $0.6\Delta\sigma_{W, 1} < 2.5R_{eH}$

$$\sigma_{m, 1} = R_{eH} - 0.6\Delta\sigma_{W, 1} \quad \text{for } 0.6\Delta\sigma_{W, 1} > R_{eH} - \sigma_{res} - \sigma_{mean, 1}$$

$$\sigma_{m, 1} = \sigma_{mean, 1} + \sigma_{res} \quad \text{for } 0.6\Delta\sigma_{W, 1} \leq R_{eH} - \sigma_{res} - \sigma_{mean, 1}$$

$\sigma_{m, j}$  = Local hot spot mean stress, in N/mm<sup>2</sup>, in the condition “j”, obtained from the following formulae:

— if  $0.24\Delta\sigma_{W, j} \geq R_{eH}$

$$\sigma_{m, j(j \neq 1)} = -0.18\Delta\sigma_{W, j}$$

— if  $0.24\Delta\sigma_{W, j} < R_{eH}$

$$\sigma_{m, j(j \neq 1)} = -R_{eH} + 0.24\Delta\sigma_{W, j} \quad \text{for } 0.24\Delta\sigma_{W, j} > R_{eH} + \sigma_{m, 1} - \sigma_{mean, 1} + \sigma_{mean, j}$$

$$\sigma_{m, j(j \neq 1)} = \sigma_{m, 1} - \sigma_{mean, 1} + \sigma_{mean, j} \quad \text{for } 0.24\Delta\sigma_{W, j} \leq R_{eH} + \sigma_{m, 1} - \sigma_{mean, 1} + \sigma_{mean, j}$$

$\sigma_{mean, j}$  = Structural hot spot mean stress, in N/mm<sup>2</sup>, corresponding to the condition “j”

$\sigma_{res}$  = Residual stress, in N/mm<sup>2</sup>, taken equal to:

$$\sigma_{res} = 0.25R_{eH} \quad \text{for stiffener end connection}$$

$$\sigma_{res} = 0 \quad \text{for non welded part and primary members (cruciform joint or butt weld)}$$

### 3 Calculation of fatigue damage

#### 3.1 Correction of the equivalent notch stress range

##### 3.1.1

The equivalent notch stress range is to be corrected with the following formula:

$$\Delta\sigma_{E, j} = f_{coat} f_{material} f_{thick} \Delta\sigma_{eq, j}$$

where:

$f_{coat}$  = Correction factor for corrosive environment, taken equal to:

$$f_{coat} = 1.05 \quad \text{for water ballast tanks and fuel oil tank}$$

$$f_{coat} = 1.03 \quad \text{for dry bulk cargo holds and void space}$$

$f_{material}$  = Correction factor for material, taken equal to:

$$f_{material} = \frac{1200}{965 + R_{eH}}$$

$f_{thick}$  = Correction factor for plate thickness, taken equal to 1.0 for hatch corners, flat bar or bulb

stiffeners, otherwise to be taken equal to:

$$f_{thick} = \left(\frac{t}{22}\right)^{0.25} \quad \text{for } t \geq 22 \text{ mm}$$

$$f_{thick} = 1.0 \quad \text{for } t < 22 \text{ mm}$$

$t$  = Net thickness, in mm, of the considered member, taken as the flange in case of stiffeners

$\Delta\sigma_{eq,j}$  = Equivalent notch stress range, in N/mm<sup>2</sup>, defined in [2.3.1].

### 3.2 Long-term distribution of stress range

#### 3.2.1

The cumulative probability density function of the long-term distribution of combined notch stress ranges is to be taken as a two-parameter Weibull distribution:

$$F(x) = 1 - \exp\left[-\left(\frac{x}{\Delta\sigma_{E,j}}\right)^\xi (\ln N_R)\right]$$

where:

$\xi$  = Weibull shape parameter, taken equal to 1.0

$N_R$  = Number of cycles, taken equal to 10<sup>4</sup>.

### 3.3 Elementary fatigue damage

#### 3.3.1

The elementary fatigue damage for each loading condition is to be calculated with the following formula:

$$D_j = \frac{\alpha_j N_L}{K} \frac{\Delta\sigma_{E,j}^4}{(\ln N_R)^{4/\xi}} \left[ \Gamma\left(\frac{4}{\xi} + 1, \nu\right) + \nu^{-3/\xi} \gamma\left(\frac{7}{\xi} + 1, \nu\right) \right]$$

where:

$K$  = S-N curve parameter, taken equal to

$$1.014 \cdot 10^{15}$$

$\alpha_j$  = Coefficient taken equal to 1.0 for the assessment of hatch corners and depending on the loading condition specified in Table 2 for primary members and longitudinal stiffeners connections.

$N_L$  = Total number of cycles for the design ship's life, taken equal to:

$$N_L = \frac{0.85 T_L}{4 \log L}$$

$T_L$  = Design life, in seconds, corresponding to 25 years of ship's life, taken equal to:

$$7.884 \cdot 10^8$$

$$\nu = \left(\frac{100.3}{\Delta\sigma_{E,j}}\right)^\xi \ln N_R$$

$\Gamma$  = Type 2 incomplete gamma function

$\gamma$  = Type 1 incomplete gamma function.

	<i>Loading conditions</i>	<b>BC-A</b>	<b>BC-B, BC-C</b>
$L < 200 \text{ m}$	Homogeneous	0.6	0.7
	Alternate	0.1	---
	Normal ballast	0.15	0.15
	Heavy ballast	0.15	0.15



$L \geq 200$ m	Homogeneous	0.25	0.5
	Alternate	0.25	---
	Normal ballast	0.2	0.2
	Heavy ballast	0.3	0.3

## 4 Fatigue strength criteria

### 4.1 Cumulative fatigue damage

#### 4.1.1

The cumulative fatigue damage  $D$  calculated for the combined equivalent stress is to comply with the following criteria:

$$D = \sum_j D_j \leq 1.0$$

where

$D_j$  = Elementary fatigue damage for each loading condition “ $j$ ”.

## SECTION 3 STRESS ASSESSMENT OF PRIMARY MEMBERS

### Symbols

For symbols not defined in this Section, refer to Ch 1, Sec 4.

- $i$  = Suffix which denotes load case “H”, “F”, “R” or “P” specified in Ch 4, Sec 4.  
“ $i1$ ” denotes load case “H1”, “F1”, “R1” or “P1” and “ $i2$ ” denotes load case “H2”, “F2”, “R2” or “P2”
- $(k)$  = Suffix which denotes loading condition, “homogeneous condition”, “alternate condition”, “normal ballast condition” or “heavy ballast condition” as defined in Sec 1, Table 2
- $\Delta\sigma_{W, i(k)}$  = Hot spot stress range, in N/mm<sup>2</sup>, in load case “ $i$ ” of loading condition “ $(k)$ ”
- $\sigma_{mean, i(k)}$  = Structural hot spot mean stress, in N/mm<sup>2</sup>, in load case “ $i$ ” of loading condition “ $(k)$ ”.

## 1 General

### 1.1 Application

#### 1.1.1

Hot spot stress ranges and structural hot spot mean stresses of primary members are to be assessed according to the requirements of this Section, with the requirements given in Ch 7, Sec 4.

## 2 Hot spot stress range

### 2.1 Stress range according to the direct method

#### 2.1.1

The hot spot stress range, in N/mm<sup>2</sup>, in load case “ $i$ ” of loading condition “ $(k)$ ” is to be obtained from the following formula:

$$\Delta\sigma_{W, i(k)} = |\sigma_{W, i1(k)} - \sigma_{W, i2(k)}|$$

where:

$\sigma_{W, i1(k)}, \sigma_{W, i2(k)}$  = Hot spot stress, in N/mm<sup>2</sup>, in load case “ $i1$ ” and “ $i2$ ” of loading condition “ $(k)$ ”, obtained by direct FEM analysis using fine mesh model specified in Ch 7, Sec 4.

### 2.2 Stress range according to the superimposition method

#### 2.2.1 Hot spot stress range

The hot spot stress range, in N/mm<sup>2</sup>, in load case “ $i$ ” of loading condition “ $(k)$ ” is to be obtained from the following formula:

$$\Delta\sigma_{W, i(k)} = \left| (\sigma_{GW, i1(k)} + \sigma_{LW, i1(k)}) - (\sigma_{GW, i2(k)} + \sigma_{LW, i2(k)}) \right|$$

where:

$\sigma_{LW, i1(k)}, \sigma_{LW, i2(k)}$  = Hot spot stress, in N/mm<sup>2</sup>, due to local loads in load cases “ $i1$ ” and “ $i2$ ” for loading condition “ $(k)$ ” obtained by the direct analysis using fine mesh FE model specified in Ch 7, Sec 4

$\sigma_{GW, i1(k)}, \sigma_{GW, i2(k)}$  = Hot spot stress, in N/mm<sup>2</sup>, due to hull girder moments in load cases “ $i1$ ” and “ $i2$ ” for loading condition “ $(k)$ ” obtained according to [2.2.2].

#### 2.2.2 Stress due to hull girder moments

The hull girder hot spot stress, in N/mm<sup>2</sup>, in load cases “ $i1$ ” and “ $i2$ ” for loading condition “ $(k)$ ” is to be obtained from the following formula:

$$\sigma_{GW, i, j(k)} = C_{WV, i, j} \sigma_{WV, i, j} - C_{WH, i, j} \sigma_{WH, (k)} \quad (j = 1, 2)$$

where:

$C_{WV, i1}, C_{WV, i2}, C_{WH, i1}, C_{WH, i2}$  = Load combination factors for each load case defined in Ch 4, Sec 4, [2.2]

$\sigma_{WV, i1}$  = Nominal hull girder stress, in N/mm<sup>2</sup>, in sagging condition induced by vertical wave bending moment

$$\sigma_{WV, i1} = \frac{M_{WV, S} (z - N)}{I_Y} 10^{-3}$$

$\sigma_{WV, i2}$  = Nominal hull girder stress, in N/mm<sup>2</sup>, in hogging condition induced by vertical wave bending moment

$$\sigma_{WV, i2} = \frac{M_{WV, H} (z - N)}{I_Y} 10^{-3}$$

$M_{WV, H}, M_{WV, S}$  = Vertical wave bending moments, in kN.m, in hogging and sagging conditions defined in Ch 4, Sec 3, [3.1.1], with  $f_p = 0.5$

$N$  = Z co-ordinate, in m, of the neutral axis, as defined in Ch 5, Sec 1

$z$  = Z co-ordinate, in m, of the point considered

$\sigma_{WH, (k)}$  = Nominal hull girder stress, in N/mm<sup>2</sup>, induced by horizontal wave bending moment

$$\sigma_{WH, (k)} = \frac{M_{WH, (k)} y}{I_Z} 10^{-3}$$

$M_{WH, (k)}$  = Horizontal wave bending moment, in kN.m, in loading condition “(k)” defined in Ch 4, Sec 3, [3.3.1], with  $f_p = 0.5$

$y$  = Y co-ordinate, in m, of the point considered, to be taken positive at port side and negative at starboard side

$I_Y, I_Z$  = Net moments of inertia of hull cross-section, in m<sup>4</sup>, about transverse and vertical axis respectively, as defined in Ch 5, Sec 1.

### 3 Hot spot mean stress

#### 3.1 Mean stress according to the direct method

##### 3.1.1

The structural hot spot mean stress, in N/mm<sup>2</sup>, in load case “i” for loading condition “(k)” is to be obtained from the following formula:

$$\sigma_{mean, i(k)} = \frac{\sigma_{W, i1(k)} + \sigma_{W, i2(k)}}{2}$$

#### 3.2 Mean stress according to the superimposition method

##### 3.2.1 Hot spot mean stresses

The structural hot spot mean stress, in N/mm<sup>2</sup>, in load case “i” for loading condition “(k)” is to be obtained from the following formula:

$$\sigma_{mean, i(k)} = \sigma_{GS, (k)} + \frac{\sigma_{LW, i1(k)} + \sigma_{LW, i2(k)}}{2}$$

where:

$\sigma_{GS, (k)}$  = Hot spot mean stress, in N/mm<sup>2</sup>, due to still water hull girder moment in loading condition “(k)” obtained according to [3.2.2].

$\sigma_{LW, i1(k)}, \sigma_{LW, i2(k)}$  = As defined in 2.2.1

##### 3.2.2 Stress due to still water hull girder moment

The hot spot stress, in N/mm<sup>2</sup>, due to still water bending moment in loading condition “(k)” is to be obtained

from the following formula:

$$\sigma_{GS, (k)} = \frac{M_{S, (k)} (z - N)}{I_Y} 10^{-3}$$

where:

$M_{S, (k)}$  = Still water vertical bending moment, in kN.m, depending on the loading condition defined in Ch 4, Sec 3, [2.2]. If the design still water bending moments are not defined at a preliminary design stage, still water bending moment in each loading condition may be obtained from the following formulae:

homogeneous condition:  $M_{S, (1)} = -0.5 F_{MS} M_{SW, S}$

alternate condition:  $M_{S, (2)} = F_{MS} M_{SW, H}$

normal ballast condition:  $M_{S, (3)} = F_{MS} M_{SW, H}$

heavy ballast condition:  $M_{S, (4)} = \begin{cases} 2.66 \frac{x}{L} M_{SW, H} & ; 0 < x \leq 0.15L \\ 2.66 \left( 0.3 - \frac{x}{L} \right) M_{SW, H} & ; 0.15L < x \leq 0.3L \\ -3.5 \left( \frac{x}{L} - 0.3 \right) M_{SW, S} & ; 0.3L < x \leq 0.5L \\ -3.5 \left( 0.7 - \frac{x}{L} \right) M_{SW, S} & ; 0.5L < x \leq 0.7L \\ 2.66 \left( \frac{x}{L} - 0.7 \right) M_{SW, H} & ; 0.7L < x \leq 0.85L \\ 2.66 \left( 1 - \frac{x}{L} \right) M_{SW, H} & ; 0.85L < x \leq L \end{cases}$

$M_{SW, H}, M_{SW, S}$  = Permissible still water bending moment, in kN.m, in hogging and sagging conditions

$F_{MS}$  = Distribution factor defined in Ch 4, Sec 3, Fig 2

## SECTION 4 STRESS ASSESSMENT OF STIFFENERS

### Symbols

For symbols not defined in this Section, refer to Ch 1, Sec 4.

- $i$  = Suffix which denotes load case “H”, “F”, “R” or “P” specified in Ch 4, Sec 4  
“ $i1$ ” denotes load case “H1”, “F1”, “R1” or “P1” and “ $i2$ ” denotes load case “H2”, “F2”, “R2” or “P2”
- $(k)$  = Suffix which denotes loading condition, “homogeneous condition”, “alternate condition”, “normal ballast condition” or “heavy ballast condition” as defined in Sec 1, Table 2
- $\Delta\sigma_{W, i(k)}$  = Hot spot stress range, in N/mm<sup>2</sup>, in load case “ $i$ ” of loading condition “ $(k)$ ”
- $\sigma_{mean, i(k)}$  = Structural hot spot mean stress, in N/mm<sup>2</sup>, in load case “ $i$ ” of loading condition “ $(k)$ ”.

## 1 General

### 1.1 Application

#### 1.1.1

Hot spot stress ranges and structural hot spot mean stresses of longitudinal stiffeners are to be assessed in line with the requirements of this Section.

#### 1.1.2

The hot spot stress ranges and structural hot spot mean stresses of longitudinal stiffeners are to be evaluated at the face plate of the longitudinal considering the type of longitudinal end connection and the following locations.

- 1) Transverse webs or floors other than those at transverse bulkhead of cargo hold or in way of stools, such that additional hot spot stress due to the relative displacement may not be considered. These longitudinal end connections are defined in Table 1. When transverse webs or floors are watertight, the coefficients  $K_{gl}$  and  $K_{gh}$  as defined in Table 2 are to be considered instead of those defined in Table 1
- 2) Transverse webs or floors at transverse bulkhead of cargo hold in way of stools, such that additional hot spot stress due to the relative displacement should be considered. These longitudinal end connections are defined in Table 2. When transverse webs or floors at transverse bulkhead of cargo hold or in way of stools are not watertight, the coefficients  $K_{gl}$  and  $K_{gh}$  as defined in Tab 1 are to be considered instead of those defined in Table 2.

## 2 Hot spot stress range

### 2.1 Stress range obtained by the direct method

#### 2.1.1

Hot spot stress ranges, in N/mm<sup>2</sup>, calculated with direct calculation for each load case “H”, “F”, “R” and “P” of each loading condition, are to be obtained according to Sec 3, [2.1].

### 2.2 Stress range according to the superimposition method

#### 2.2.1

The hot spot stress ranges, in N/mm<sup>2</sup>, for each load case “H”, “F”, “R” and “P” of each loading condition according to the superimposition method are to be obtained according to Sec 3, [2.2].

### 2.3 Stress range according to the simplified procedure

#### 2.3.1 Hot spot stress ranges

The hot spot stress range, in N/mm<sup>2</sup>, due to dynamic loads in load case “ $i$ ” of loading condition “ $(k)$ ” is to be

obtained from the following formula:

$$\Delta\sigma_{W,i(k)} = \left| \left( \sigma_{GW,i1(k)} + \sigma_{W1,i1(k)} - \sigma_{W2,i1(k)} + \sigma_{d,i1(k)} \right) - \left( \sigma_{GW,i2(k)} + \sigma_{W1,i2(k)} - \sigma_{W2,i2(k)} + \sigma_{d,i2(k)} \right) \right|$$

where

- $\sigma_{GW,i1(k)}, \sigma_{GW,i2(k)}$  = Stress due to hull girder moment, defined in [2.3.2]  
 $\sigma_{W1,i1(k)}, \sigma_{W1,i2(k)}$  = Stress  $\sigma_{LW,ij(k)}, \sigma_{CW,ij(k)}$  and  $\sigma_{LCW,ij(k)}$  due to hydrodynamic or inertial pressure when the pressure is applied on the same side as the ordinary stiffener depending on the considered case  
 $\sigma_{W2,i1(k)}, \sigma_{W2,i2(k)}$  = Stress  $\sigma_{LW,ij(k)}, \sigma_{CW,ij(k)}$  and  $\sigma_{LCW,ij(k)}$  due to hydrodynamic or inertial pressure when the pressure is applied on the side opposite to the stiffener depending on the considered case  
 $\sigma_{LW,i1(k)}, \sigma_{LW,i2(k)}$  = Stresses due to wave pressure, defined in [2.3.3]  
 $\sigma_{CW,i1(k)}, \sigma_{CW,i2(k)}$  = Stresses due to liquid pressure, defined in [2.3.4]  
 $\sigma_{LCW,i1(k)}, \sigma_{LCW,i2(k)}$  = Stresses due to dry bulk cargo pressure, defined in [2.3.5]  
 $\sigma_{d,i1(k)}, \sigma_{d,i2(k)}$  = Stress due to relative displacement of transverse bulkhead or floor in way of stools, defined in [2.3.6].

### 2.3.2 Stress due to hull girder moments

The hull girder hot spot stress, in N/mm<sup>2</sup>, in load case “i1” and “i2” for loading condition “(k)” is to be obtained from the following formula:

$$\sigma_{GW,ij(k)} = K_{gh} \cdot (C_{WV,ij} \sigma_{WV,ij} - C_{WH,ij} \sigma_{WH,(k)}) \quad (j = 1, 2)$$

where:

- $K_{gh}$  = Geometrical stress concentration factor for nominal hull girder stress.  $K_{gh}$  is given in Table 1 and Table 2 for the longitudinal end connection specified in [1.1.2] (1) and [1.1.2] (2), respectively. The stress concentration factor can be evaluated directly by the FE analysis.  
 $C_{WV,i1}, C_{WV,i2}, C_{WH,i1}, C_{WH,i2}$  = Load combination factors for each load case defined in Ch 4, Sec 4, [2.2]  
 $\sigma_{WV,i1}, \sigma_{WV,i2}, \sigma_{WH,(k)}$  = Nominal hull girder stresses, in N/mm<sup>2</sup>, defined in Sec 3, [2.2.2]

### 2.3.3 Stress due to wave pressure

The hot spot stress, in N/mm<sup>2</sup>, due to the wave pressure in load case “i1” and “i2” for loading condition “(k)” is to be obtained from the following formula:

$$\sigma_{LW,ij(k)} = \frac{K_{gl} K_s p_{CW,ij(k)} S \ell^2 \left( 1 - \frac{6x_f}{\ell} + \frac{6x_f^2}{\ell^2} \right)}{12w} 10^3 \quad (j = 1, 2)$$

$$p_{CW,i1(k)} = \begin{cases} 2C_{NE,i1(k)} p_{W,i1(k)} & ; C_{NE,i1(k)} < 0.5 \\ p_{W,i1(k)} & ; C_{NE,i1(k)} \geq 0.5 \end{cases}$$

$$p_{CW,i2(k)} = \begin{cases} 0 & ; C_{NE,i2(k)} < 0.5 \\ (2C_{NE,i2(k)} - 1) p_{W,i2(k)} & ; C_{NE,i2(k)} \geq 0.5 \end{cases}$$

where:

- $p_{W,ij(k)}$  = Hydrodynamic pressure, in kN/m<sup>2</sup>, specified in Ch 4, Sec 5, [1.3], [1.4] and [1.5], with  $f_p = 0.5$ , in load case “i1” and “i2” for loading condition “(k)”. When the location of the considered member is above the waterline, the hydrodynamic pressure is to be taken as the pressure at waterline.  
 $K_{gl}$  = Geometrical stress concentration factor for stress due to lateral pressure.  $K_{gl}$  is given in Table 1 and Table 2 for the longitudinal end connection specified in [1.1.2] (1) and [1.1.2]

(2), respectively. The stress concentration factor can be evaluated directly by the FE analysis.

$K_s$  = Geometrical stress concentration factor due to stiffener geometry

$$K_s = 1 + \left[ \frac{t_f(a^2 - b^2)}{2w_b} \right] \left[ 1 - \frac{b}{b_f} \left( 1 + \frac{w_b}{w_a} \right) \right] 10^{-3}$$

$a, b$  = Eccentricity, in mm, of the face plate as defined in Fig 1. For angle profile, “ $b$ ” is to be taken as half the net actual thickness of the web.

$t_f, b_f$  = thickness and breadth of face plate, in mm, respectively, as defined in Fig 1.

$w_a, w_b$  = Net section modulus in A and B respectively (see Fig.1), in  $\text{cm}^3$ , of the stiffener about the neutral axis parallel to Z axis without attached plating.

$C_{NE, ij(k)}$  = Correction factor for the non linearity of the wave pressure range in load case “ $i1$ ” and “ $i2$ ” of loading condition “ $(k)$ ”

$$C_{NE, ij(k)} = \begin{cases} \exp \left[ - \left( \frac{z - T_{LC(k)} + \frac{|p_{W, ij(k), WL}|}{\rho g}}{\frac{|p_{W, ij(k), WL}|}{\rho g} (-\ln 0.5)^{-1/2.5}} \right)^{2.5} \right] & \text{for } z > T_{LC(k)} - \frac{|p_{W, ij(k), WL}|}{\rho g} \\ 1.0 & \text{for } z \leq T_{LC(k)} - \frac{|p_{W, ij(k), WL}|}{\rho g} \end{cases}$$

$T_{LC(k)}$  = Draught, in m, of the considered loading condition “ $(k)$ ”

$p_{W, ij(k), WL}$  = Hydrodynamic pressure, in  $\text{kN/m}^2$ , at water line in load case “ $i1$ ” and “ $i2$ ” of loading condition “ $(k)$ ”

$z$  = Z co-ordinate, in m, of the point considered

$s$  = Stiffener spacing, in m

$\ell$  = Span, in m, to be measured as shown in Fig 2. The ends of the span are to be taken at points where the depth of the end bracket, measured from the face plate of the stiffener is equal to half the depth of the stiffener

$x_f$  = Distance, in m, to the hot spot from the closest end of the span  $\ell$  (see Fig 2)

$w$  = Net section modulus, in  $\text{cm}^3$ , of the considered stiffener. The section modulus  $w$  is to be calculated considering an effective breadth  $s_e$ , in m, of attached plating obtained from the following formulae:

$$s_e = \begin{cases} 0.67s \cdot \sin \left[ \frac{\pi}{6} \left( \frac{\ell(1-1/\sqrt{3})}{2s} \right) \right] & \text{for } \frac{\ell}{s} \leq \frac{6}{1-1/\sqrt{3}} \\ 0.67s & \text{for } \frac{\ell}{s} > \frac{6}{1-1/\sqrt{3}} \end{cases}$$

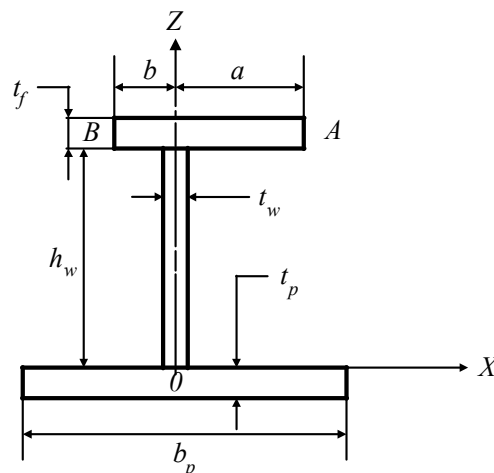
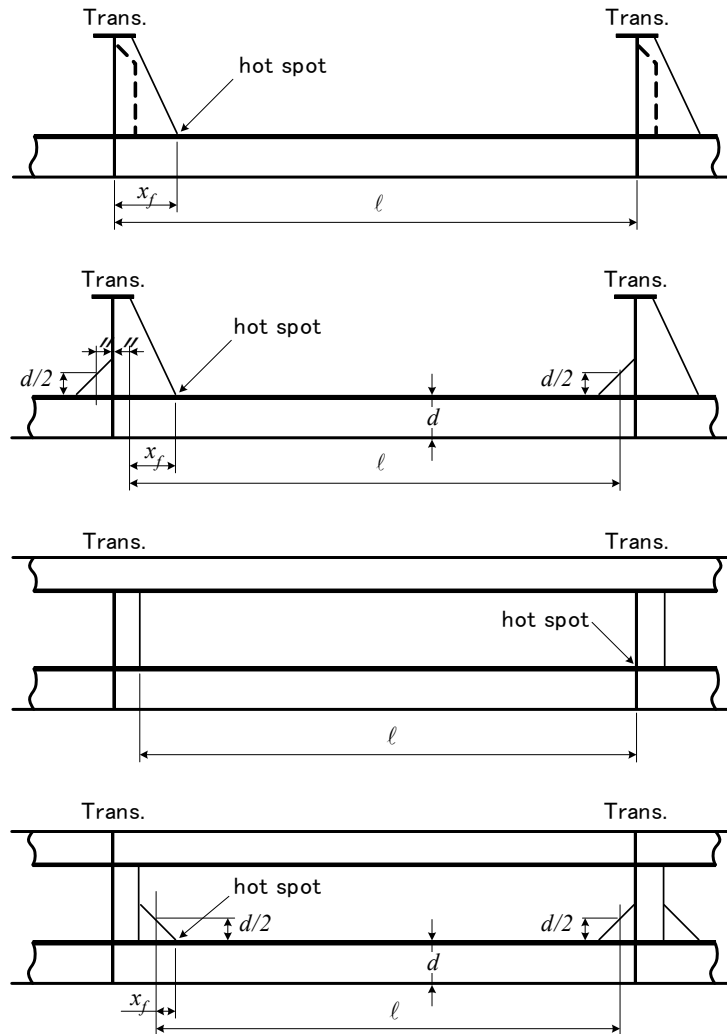

Fig. 1  
Sectional parameters of a stiffener



**Fig. 2**  
**Span and hot spot of longitudinal stiffeners**

### 2.3.4 Stress due to liquid pressure

The hot spot stress, in N/mm<sup>2</sup>, due to the liquid pressure in load case “i1” and “i2” for loading condition “(k)” is to be obtained from the following formula:

$$\sigma_{CW, ij(k)} = \frac{K_{gl} K_s C_{NI, ij(k)} P_{BW, ij(k)} S \ell^2 \left( 1 - \frac{6x_f}{\ell} + \frac{6x_f^2}{\ell^2} \right)}{12w} \cdot 10^3 \quad (j=1, 2)$$

where:

$P_{BW, ij(k)}$  = Inertial pressure, in kN/m<sup>2</sup>, due to liquid specified in Ch 4, Sec 6, [2.2], with  $f_p = 0.5$ , in load case “i1” and “i2” for loading condition “(k)”. Where the considered location is located in fuel oil, other oil or fresh water tanks, no inertial pressure is considered for the tank top longitudinals and when the location of the considered member is above the liquid surface in static and upright condition, the inertial pressure is to be taken at the liquid surface line.

$C_{NI, ij(k)}$  = Correction factor for the non linearity of the inertial pressure range due to liquid in load case “i1” and “i2” for loading condition “(k)”



$$C_{NI, ij(k)} = \begin{cases} \exp \left[ - \left( \frac{z - z_{SF} + \frac{|P_{BW, ij(k), SF}|}{\rho g}}{\frac{|P_{BW, ij(k), SF}|}{\rho g} (-\ln 0.5)^{-1/2.5}} \right)^{2.5} \right] & \text{for } z > z_{SF} - \frac{|P_{BW, ij(k), SF}|}{\rho g} \\ 1.0 & \text{for } z \leq z_{SF} - \frac{|P_{BW, ij(k), SF}|}{\rho g} \end{cases}$$

- $z_{SF}$  = Z co-ordinate, in m, of the liquid surface. In general, it is taken equal to “ $z_{top}$ ” defined in Ch 4 Sec 6. If the considered location is located in fuel oil, other oil or fresh water tanks, it may be taken as the distance to the half height of the tank.
- $z$  = Z co-ordinate, in m, of the point considered
- $P_{BW, ij(k), SF}$  = Inertial pressure due to liquid, in kN/m<sup>2</sup>, taken at the liquid surface in load case “i1” and “i2” for loading condition “(k)”. In calculating the inertial pressure according to Ch 4 Sec 6, [2.2.1], x and y coordinates of the reference point are to be taken as liquid surface instead of tank top.
- $K_{gl}, K_s$  = the stress concentration factor defined in [2.3.3].

### 2.3.5 Stress due to dry bulk cargo pressure

The hot spot stress, in N/mm<sup>2</sup>, due to the dry bulk cargo pressure in load case “i1” and “i2” for loading condition “(k)” is to be obtained from the following formula:

$$\sigma_{LCW, ij(k)} = \frac{K_{gl} K_s P_{CW, ij(k)} S \ell^2 \left( 1 - \frac{6x_f}{\ell} + \frac{6x_f^2}{\ell^2} \right)}{12w} 10^3 \quad (j=1, 2)$$

where:

- $P_{CW, ij(k)}$  = Inertial pressure, in kN/m<sup>2</sup>, due to dry bulk cargo specified in Ch 4, Sec 6, [1.3], with  $f_p = 0.5$ , in load case “i1” and “i2” for loading condition “(k)”.

### 2.3.6 Stress due to relative displacement of transverse bulkhead or floor in way of transverse bulkhead or stool

For longitudinal end connection specified in [1.1.2] (2), the additional hot spot stress, in N/mm<sup>2</sup>, due to the relative displacement in the direction perpendicular to the attached plate between the transverse bulkhead or floor in way of stools and the adjacent transverse web or floor in load case “i1” and “i2” for loading condition “(k)” is to be obtained from the following formula.

$$\sigma_{d, ij(k)} = \begin{cases} K_{dF-a} \sigma_{dF-a, ij(k)} + K_{dA-a} \sigma_{dA-a, ij(k)} & \text{for point "a"} \\ K_{dF-f} \sigma_{dF-f, ij(k)} + K_{dA-f} \sigma_{dA-f, ij(k)} & \text{for point "f"} \end{cases} \quad (j=1, 2)$$

where:

- $a, f$  = Suffix which denotes the location considered as indicated in Table 2
- $A, F$  = Suffix which denotes the direction, forward (F) and afterward (A), of the transverse web or floor where the relative displacement is occurred as indicated in Table 2 (see Fig 3)

- $\sigma_{dF-a, ij(k)}, \sigma_{dA-a, ij(k)}, \sigma_{dF-f, ij(k)}, \sigma_{dA-f, ij(k)}$  = Additional stress at point “a” and “f”, in N/mm<sup>2</sup>, due to the relative displacement between the transverse bulkhead or floors in way of stools and the forward (F) and afterward (A) transverse web or floor respectively in load case “i1” and “i2” for loading condition “(k)”

$$\sigma_{dF-a,ij(k)} = \frac{3.9\delta_{F,ij(k)}EI_A I_F}{w_A \ell_F (\ell_A I_F + \ell_F I_A)} \left( 1 - 1.15 \frac{|x_{fA}|}{\ell_A} \right) 10^{-5}$$

$$\sigma_{dA-a,ij(k)} = \left[ \frac{3.9\delta_{A,ij(k)}EI_A I_F}{w_A \ell_A (\ell_A I_F + \ell_F I_A)} \left( 1 - 1.15 \frac{|x_{fA}|}{\ell_A} \right) - \frac{0.9\delta_{A,ij(k)}EI_A |x_{fA}|}{w_A \ell_A^3} \right] 10^{-5}$$

$$\sigma_{dF-f,ij(k)} = \left[ \frac{3.9\delta_{F,ij(k)}EI_A I_F}{w_F \ell_F (\ell_A I_F + \ell_F I_A)} \left( 1 - 1.15 \frac{|x_{fF}|}{\ell_F} \right) - \frac{0.9\delta_{F,ij(k)}EI_F |x_{fF}|}{w_F \ell_F^3} \right] 10^{-5}$$

$$\sigma_{dA-f,ij(k)} = \frac{3.9\delta_{A,ij(k)}EI_A I_F}{w_F \ell_A (\ell_A I_F + \ell_F I_A)} \left( 1 - 1.15 \frac{|x_{fF}|}{\ell_F} \right) 10^{-5}$$

$d_{F,ij(k)}, d_{A,ij(k)}$  = Relative displacement, in mm, in the direction perpendicular to the attached plate between the transverse bulkhead or floor in way of stools and the forward (F) and afterward (A) transverse web or floor in load case “i1” and “i2” for loading condition “(k)” (see Fig 3)

- For longitudinals penetrating floors in way of stools  
Relative displacement is defined as the displacement of the longitudinal in relation to the line passing through the stiffener end connection at the base of the stool measured at the first floor forward (F) or afterward (A) of the stool.
- For longitudinals other than (a)  
Relative displacement is defined as the displacement of the longitudinal in relation to its original position measured at the first forward (F) or afterward (A) of the transverse bulkhead.

Where the stress of the face of longitudinal at the assessment point due to relative displacement is tension, the sign of the relative displacement is positive.

$I_F, I_A$  = Net moment of inertia, in cm<sup>4</sup>, of forward (F) and afterward (A) longitudinal

$K_{dF-a}, K_{dA-a}, K_{dF-f}, K_{dA-f}$  = Stress concentration factor for stiffener end connection at point “a” and “f” subject to relative displacement between the transverse bulkhead and the forward (F) and afterward (A) transverse web or floors in way of stool respectively as defined in Table 2. The stress concentration can be evaluated directly by the FE analysis when the detail of end connection is not defined in Table 2.

$\ell_F, \ell_A$  = Span, in m, of forward (F) and afterward (A) longitudinal to be measured as shown in Fig 2  
 $x_{fF}, x_{fA}$  = Distance, in m, to the hot spot from the closest end of  $\ell_F$  and  $\ell_A$  respectively (see Fig 2).

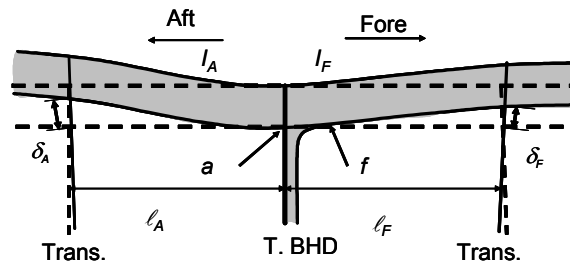

Fig. 3  
Definition of the relative displacement (Example of the side longitudinal)

### 3 Hot spot mean stress

#### 3.1 Mean stress according to the direct method

##### 3.1.1

The structural hot spot mean stress, in N/mm<sup>2</sup>, in each loading condition calculated with the direct method is

to be obtained according to Sec 3, [3.1].

### 3.2 Mean stress according to the superimposition method

#### 3.2.1

The structural hot spot mean stress, in N/mm<sup>2</sup>, in each loading condition calculated with the superimposition method is to be obtained according to Sec 3, [3.2].

### 3.3 Mean stress according to the simplified procedure

#### 3.3.1 Hot spot mean stresses

The structural hot spot mean stress, in N/mm<sup>2</sup>, in loading condition “(k)” regardless of load case “i” is to be obtained from the following formula:

$$\sigma_{mean, (k)} = \sigma_{GS, (k)} + \sigma_{S1, (k)} - \sigma_{S2, (k)} + \sigma_{dS, (k)}$$

where:

- $\sigma_{GS, (k)}$  = Stress due to still water hull girder moment, defined in [3.3.2]
- $\sigma_{S1, (k)}$  = Stress due to static pressure when the pressure is applied on the same side as the ordinary stiffener depending on the considered case
- $\sigma_{S2, (k)}$  = Stress due to static pressure when the pressure is applied on the side opposite to the stiffener depending on the considered case
- $\sigma_{dS, (k)}$  = Stress due to relative displacement of transverse bulkhead in still water, defined in [3.3.6].

#### 3.3.2 Stress due to still water hull girder moment

The hot spot stress due to still water bending moment, in N/mm<sup>2</sup>, in loading condition “(k)” is to be obtained with the following formula:

$$\sigma_{GS, (k)} = K_{gh} \frac{M_{S, (k)} (z - N)}{I_Y} 10^{-3}$$

where:

$M_{S, (k)}$  = Still water vertical bending moment, in kN.m, defined in Sec 3, [3.2.2].

#### 3.3.3 Stress due to hydrostatic and hydrodynamic pressure

The hot spot stress due to hydrostatic and hydrodynamic pressure, in N/mm<sup>2</sup>, in loading condition “(k)” is to be obtained with the following formula:

$$\sigma_{LS, (k)} = \frac{K_{gl} K_s \left\{ p_{S, (k)} + \frac{p_{CW, i1(k)} + p_{CW, i2(k)}}{2} \right\} s \ell^2 \left( 1 - \frac{6x_f}{\ell} + \frac{6x_f^2}{\ell^2} \right)}{12w} \cdot 10^3$$

where:

- $p_{S, (k)}$  = Hydrostatic pressure, in kN/m<sup>2</sup>, in loading condition “(k)” specified in Ch 4, Sec 5, [1.2].
- $p_{CW, ij(k)}$  = Corrected hydrodynamic pressure, in kN/m<sup>2</sup>, according to [2.3.3], with  $f_p = 0.5$ , in load case “i1” and “i2” for loading condition “(k)”.
- $i$  = Suffix which denotes the load case specified in Sec 2 [2.1.1], when calculating the mean stress, “I” is to be used.

#### 3.3.4 Stress due to liquid pressure in still water

The structural hot spot mean stress due to liquid pressure in still water, in N/mm<sup>2</sup>, in loading condition “(k)” is to be obtained with the following formula:

$$\sigma_{CS, (k)} = \frac{K_{gl} K_s p_{CS, (k)} s \ell^2 \left( 1 - \frac{6x_f}{\ell} + \frac{6x_f^2}{\ell^2} \right)}{12w} 10^3$$

where:

$p_{CS, (k)}$  = Liquid pressure in still water, in kN/m<sup>2</sup>, in loading condition “(k)” specified in Ch 4, Sec 6, [2.1].

Where the considered location is located in fuel oil, other oil or fresh water tanks,  $d_{AP}$  and  $P_{PV}$  defined in Ch 4 Sec 6 are to be taken equal to 0 and  $z_{TOP}$  specified in Ch 4 Sec 6, [2.1] is to be taken equal to  $z_{SF}$  specified in [2.3.4].

### 3.3.5 Stress due to dry bulk cargo pressure in still water

The structural hot spot mean stress due to dry bulk cargo pressure in still water, in  $N/mm^2$ , in loading condition “(k)” is to be obtained with the following formula:

$$\sigma_{LCS, (k)} = \frac{K_{gl} K_s p_{CS, (k)} S \ell^2 \left( 1 - \frac{6x_f}{\ell} + \frac{6x_f^2}{\ell^2} \right)}{12w} 10^3$$

where:

$p_{CS, (k)}$  = Dry bulk cargo pressure in still water, in  $kN/m^2$ , in loading condition “(k)” specified in Ch 4, Sec 6, [1.2].

### 3.3.6 Stress due to relative displacement of transverse bulkhead in still water

The additional hot spot mean stress, in  $N/mm^2$ , due to the relative displacement in the transverse direction between the transverse bulkhead and the adjacent transverse web or floor in loading condition “(k)”, is to be obtained with the following formula:

$$\sigma_{dS, (k)} = \begin{cases} K_{dF-a} \sigma_{dSF-a, (k)} + K_{dA-a} \sigma_{dSA-a, (k)} & \text{for point "a"} \\ K_{dF-f} \sigma_{dSF-f, (k)} + K_{dA-f} \sigma_{dSA-f, (k)} & \text{for point "f"} \end{cases}$$

where:

$\sigma_{dSF-a, (k)}$ ,  $\sigma_{dSA-a, (k)}$ ,  $\sigma_{dSF-f, (k)}$ ,  $\sigma_{dSA-f, (k)}$  = Additional stress at point “a” and “f”, in  $N/mm^2$ , due to the relative displacement between the transverse bulkhead and the forward (F) and afterward (A) transverse web or floor respectively in loading condition (k)

$$\sigma_{dSF-a, (k)} = \frac{3.9 \delta_{SF, (k)} E I_A I_F}{w_A \ell_F (\ell_A I_F + \ell_F I_A)} \left( 1 - 1.15 \frac{|x_{fA}|}{\ell_A} \right) 10^{-5}$$

$$\sigma_{dSA-a, (k)} = \left[ \frac{3.9 \delta_{SA, (k)} E I_A I_F}{w_A \ell_A (\ell_A I_F + \ell_F I_A)} \left( 1 - 1.15 \frac{|x_{fA}|}{\ell_A} \right) - \frac{0.9 \delta_{SA, (k)} E I_A |x_{fA}|}{w_A \ell_A^3} \right] 10^{-5}$$

$$\sigma_{dSF-f, (k)} = \left[ \frac{3.9 \delta_{SF, (k)} E I_A I_F}{w_F \ell_F (\ell_A I_F + \ell_F I_A)} \left( 1 - 1.15 \frac{|x_{fF}|}{\ell_F} \right) - \frac{0.9 \delta_{SF, (k)} E I_F |x_{fF}|}{w_F \ell_F^3} \right] 10^{-5}$$

$$\sigma_{dSA-f, (k)} = \frac{3.9 \delta_{SA, (k)} E I_A I_F}{w_F \ell_A (\ell_A I_F + \ell_F I_A)} \left( 1 - 1.15 \frac{|x_{fF}|}{\ell_F} \right) 10^{-5}$$

$d_{SF, (k)}$ ,  $d_{SA, (k)}$  = Relative displacement, in mm, in still water in the transverse direction between the transverse bulkhead and the forward (F) and afterward (A) transverse web or floor respectively in loading condition (k)

**Table 1: Stress concentration factors for non-watertight longitudinal end connection at transverse webs or floors other than transverse bulkheads or floors in way of stools**

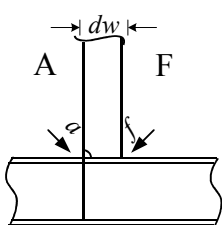
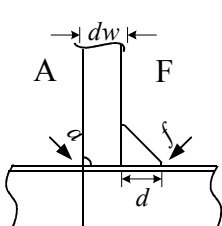
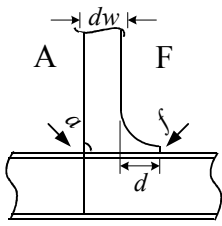
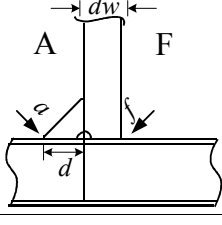
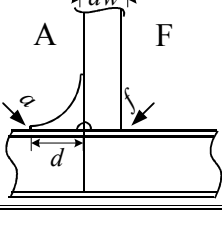
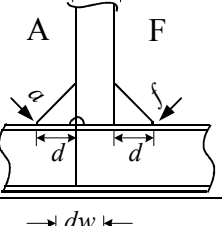
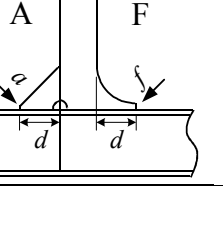
Bracket type	Assessed point	Bracket size	Stress concentration factors	
			$K_{gl}$	$K_{gh}$
1 	<i>a</i>	-----	1.65	1.1
2 	<i>a</i>	$dw \leq d \leq 1.5dw$	1.55	1.1
		$1.5dw \leq d$	1.5	1.05
3 	<i>a</i>	$dw \leq d \leq 1.5dw$	1.5	1.1
		$1.5dw \leq d$	1.45	1.05
4 	<i>f</i>	$dw \leq d \leq 1.5dw$	1.4	1.1
		$1.5dw \leq d$	1.4	1.05
5 	<i>f</i>	$dw \leq d \leq 1.5dw$	1.35	1.1
		$1.5dw \leq d$	1.35	1.05
6 	<i>a</i>	$dw \leq d \leq 1.5dw$	1.15	1.05
		$1.5dw \leq d$	1.1	1.05
7 	<i>a</i>	$dw \leq d < 1.5dw$	1.15	1.05
		$1.5dw \leq d$	1.1	1.05

**Table 1: Stress concentration factors for non-watertight longitudinal end connection at transverse webs or floors other than transverse bulkheads or floors in way of stools (Continued)**

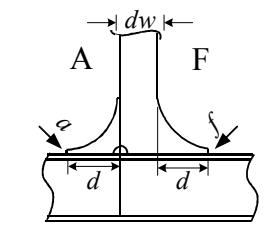
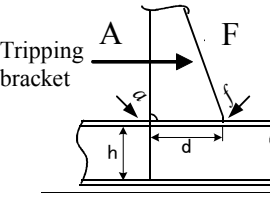
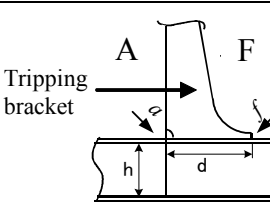
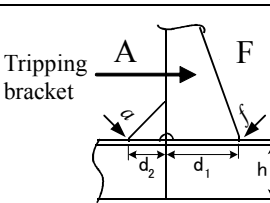
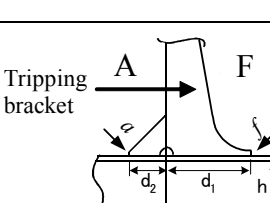
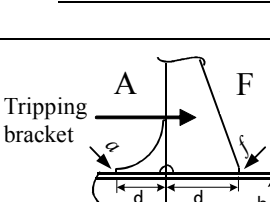
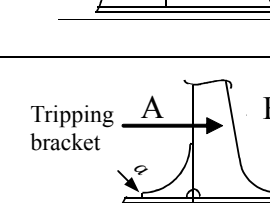
Bracket type	Assessed point	Bracket size	Stress concentration factors	
			$K_{gl}$	$K_{gh}$
	a	$dw \leq d < 1.5dw$	1.1	1.1
		$1.5dw \leq d$	1.05	1.05
	a	$d \leq 2h$	1.45	1.1
	a	$d \leq 2.5h$	1.35	1.1
	a	$d1 \leq 2h$ and $h \leq d2$	1.15	1.1
	f		1.85	1.1
	a	$d1 \leq 2.5h$ and $h \leq d2$	1.15	1.1
	f		1.35	1.1
	a	$d1 \leq 2h$ and $h \leq d2$	1.1	1.1
	f		2.05	1.1
	a	$d1 \leq 2.5h$ and $h \leq d2$	1.1	1.1
	f		1.8	1.1

**Table 2: Stress concentration factors for watertight longitudinal end connection at transverse bulkheads and floors in way of stools**

Bracket type	Assessed point	Bracket size	Stress concentration factors			
			$K_{gl}$	$K_{gh}$	$K_{dF}$	$K_{dA}$
	<i>a</i>	----	1.5	1.1	1.15	1.5
	<i>f</i>	----	1.1	1.05	1.55	1.05
	<i>a</i>	$dw \leq d \leq 1.5dw$	1.45	1.1	1.15	1.4
		$1.5dw \leq d$	1.4	1.05	1.15	1.35
	<i>f</i>	$dw \leq d \leq 1.5dw$	1.1	1.05	1.15	1.1
		$1.5dw \leq d$	1.05	1.05	1.1	1.05
	<i>a</i>	$dw \leq d \leq 1.5dw$	1.4	1.1	1.1	1.35
		$1.5dw \leq d$	1.35	1.05	1.05	1.3
	<i>f</i>	$dw \leq d \leq 1.5dw$	1.05	1.05	1.1	1.05
		$1.5dw \leq d$	1.05	1.05	1.05	1.05
	<i>a</i>	$dw \leq d \leq 1.5dw$	1.1	1.05	1.05	1.25
		$1.5dw \leq d$	1.05	1.05	1.05	1.2
	<i>f</i>	$dw \leq d \leq 1.5dw$	1.3	1.1	1.35	1.05
		$1.5dw \leq d$	1.3	1.05	1.3	1.05
	<i>a</i>	$dw \leq d \leq 1.5dw$	1.1	1.05	1.05	1.2
		$1.5dw \leq d$	1.05	1.05	1.05	1.15
	<i>f</i>	$dw \leq d \leq 1.5dw$	1.3	1.1	1.55	1.1
		$1.5dw \leq d$	1.3	1.05	1.5	1.05
	<i>a</i>	$dw \leq d \leq 1.5dw$	1.1	1.05	1.05	1.1
		$1.5dw \leq d$	1.05	1.05	1.05	1.05
	<i>f</i>	$dw \leq d \leq 1.5dw$	1.05	1.05	1.1	1.05
		$1.5dw \leq d$	1.05	1.05	1.05	1.05

Table 2: Stress concentration factors for watertight longitudinal end connection at transverse bulkheads and floors in way of stools (Continued)							
Bracket type	Assessed point	Bracket size	Stress concentration factors				
			$K_{gl}$	$K_{gh}$	$K_{dF}$	$K_{dA}$	
	a	$dw \leq d \leq 1.5dw$	1.1	1.05	1.05	1.2	
		$1.5dw \leq d$	1.05	1.05	1.05	1.15	
	f	$dw \leq d \leq 1.5dw$	1.05	1.05	1.05	1.05	
		$1.5dw \leq d$	1.05	1.05	1.05	1.05	
	a	$dw \leq d \leq 1.5dw$	1.1	1.1	1.05	1.15	
		$1.5dw \leq d$	1.05	1.05	1.05	1.1	
	f	$dw \leq d \leq 1.5dw$	1.05	1.05	1.1	1.05	
		$1.5dw \leq d$	1.05	1.05	1.05	1.05	
	a	$d \leq 2h$	1.4	1.05	1.05	1.75	
	f		1.6	1.05	1.7	1.05	
	a	$d \leq 2.5h$	1.3	1.05	1.05	1.75	
	f		1.55	1.05	1.3	1.05	
	a	$d_1 \leq 2h$ and $h \leq d_2$	1.1	1.05	1.05	1.2	
	f		1.75	1.05	1.4	1.05	
	a	$d_1 \leq 2.5h$ and $h \leq d_2$	1.1	1.05	1.05	1.2	
	f		1.3	1.05	1.05	1.05	



**Table 2: Stress concentration factors for watertight longitudinal end connection at transverse bulkheads and floors in way of stools (Continued)**

Bracket type	Assessed point	Bracket size	Stress concentration factors			
			$K_{gl}$	$K_{gh}$	$K_{dF}$	$K_{dA}$
	<i>a</i>	$d_1 \leq 2h$ and $h \leq d_2$	1.05	1.05	1.05	1.15
	<i>f</i>		1.95	1.05	1.55	1.05
	<i>a</i>	$d_1 \leq 2.5h$ and $h \leq d_2$	1.05	1.05	1.05	1.15
	<i>f</i>		1.7	1.05	1.15	1.05

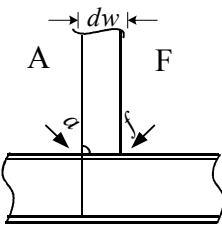
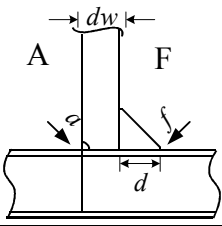
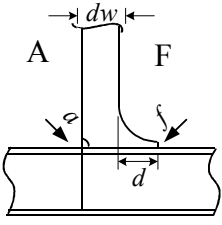
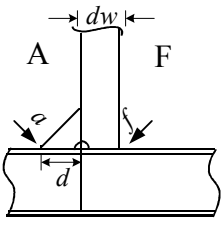
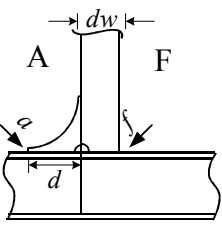
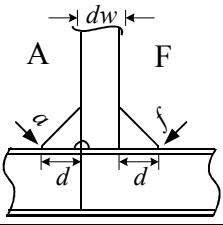
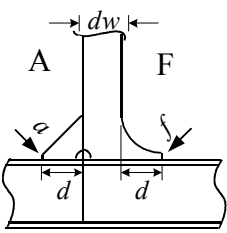
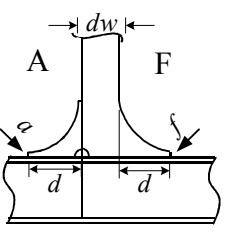
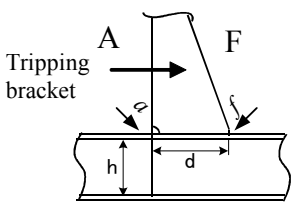
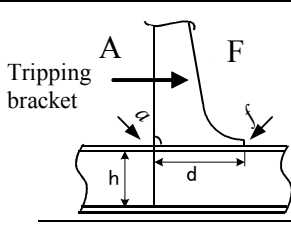
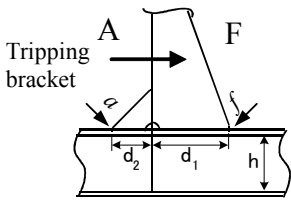
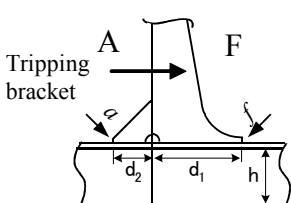
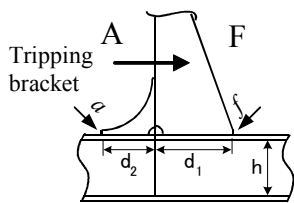
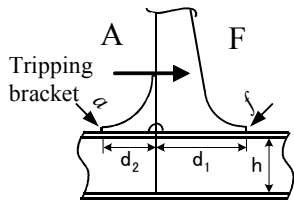
## SECTION 5 STRESS ASSESSMENT OF HATCH CORNERS

### 1 General

#### 1.1 Application

##### 1.1.1

Hot spot stress ranges and structural hot spot mean stresses of hatch corners based on the simplified procedure are to be assessed according to the requirements of this Section.

### 2 Nominal stress range

#### 2.1 Nominal stress range due to wave torsional moment

##### 2.1.1

The nominal stress range, in N/mm<sup>2</sup>, due to cross deck bending induced by wave torsion moments is to be obtained from the following formula:

$$\Delta\sigma_{WT} = \frac{2}{1000} F_S F_L \frac{Q \cdot B_H}{W_Q}$$

Where:

$$Q = \frac{1000u}{\frac{(B_H + b_s)^3}{12EI_Q} + \frac{2.6B_H}{EA_Q}}$$

$u$  = Displacement of hatch corner in longitudinal direction, in m, taken equal to:

$$u = \frac{31.2}{1000} \frac{M_{WT} \omega}{I_T E DOC}$$

$DOC$  = Deck opening coefficient, taken equal to:

$$DOC = \frac{L_C B}{\sum_{i=1}^n L_{H,i} B_{H,i}}$$

$M_{WT}$  = Maximum wave torsional moment, in kN.m, defined in Ch 4, Sec 3, [3.4.1], with  $f_p = 0.5$

$F_S$  = Stress correction factor, taken equal to:

$$F_S = 5$$

$F_L$  = Correction factor for longitudinal position of hatch corner, taken equal to:

$$F_L = 1.75 \frac{x}{L} \quad \text{for } 0.57 \leq x/L \leq 0.85$$

$$F_L = 1.0 \quad \text{for } x/L < 0.57 \text{ and } x/L > 0.85$$

$B_H$  = Breadth of hatch opening, in m

$W_Q$  = Section modulus of the cross deck about z-axis, in m<sup>3</sup>, including upper stool, near hatch corner (see Fig 2)

$I_Q$  = Moment of inertia of the cross deck about z-axis, in m<sup>4</sup>, including upper stool, near the hatch corner (see Fig 2)

$A_Q$  = Effective shear area of the whole section of the cross deck, in m<sup>2</sup>, including upper stool, near the hatch corner (see Fig 2). For the determination of the effective shear area the consideration of only the plate elements is sufficient, and the stiffeners can be neglected.

$b_S$  = Breadth of remaining deck strip on one side, in m, beside the hatch opening

$I_T$  = Torsion moment of inertia of ships cross section, in m<sup>4</sup>, calculated within cross deck area by neglecting upper and lower stool of the bulkhead (see Fig 1). It may be calculated according to App 1

$\omega$  = Sector coordinate, in m<sup>2</sup>, calculated at the same cross section as  $I_T$  and at the  $Y$  and  $Z$  location of the

- hatch corner (see Fig 1) It may be calculated according to App 1
- $L_C$  = Length of cargo area, in m, being the distance between engine room bulkhead and collision bulkhead
  - $B_{H,i}$  = Breadth of hatch opening of hatch  $i$ , in m
  - $L_{H,i}$  = Length of hatch opening of hatch  $i$ , in m
  - $n$  = Number of hatches.

er: 21 (Omega distribution)

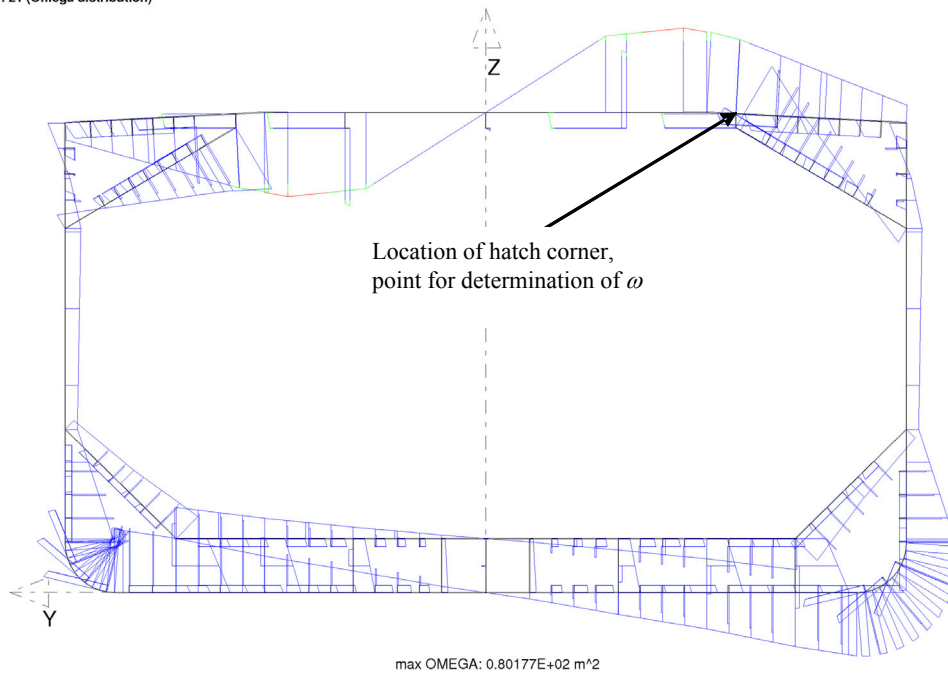

**Fig. 1**  
Cross section for determination of  $I_T$  and  $\omega$

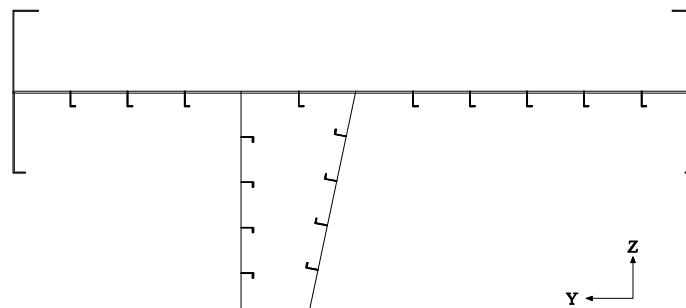

**Fig. 2**  
Elements to be considered for the determination of  $A_Q$ ,  $W_Q$  and  $I_Q$

## 2.2 Nominal mean stress

### 2.2.1

The mean stress due to still water bending moment within the cross deck is set to 0.

### 3 Hot spot stress

#### 3.1 Hot spot stress range

##### 3.1.1

The hot spot stress range, in N/mm<sup>2</sup>, is to be obtained from the following formula:

$$\Delta\sigma_W = K_{gh} \cdot \Delta\sigma_{WT}$$

where:

$K_{gh}$  = Stress concentration factor for the hatch corner, taken equal to:

$$K_{gh} = \frac{r_a + 2r_b}{3r_a} \left\{ 1 + \left( \frac{2b}{1.23\ell_{CD} + 1.6b} \frac{0.22\ell_{CD}}{r_a} \right)^{0.65} \right\}$$

to be taken not less than 1.0

$r_a$  = Radius, in m, in major axis

$r_b$  = Radius, in m, in minor axis (if the shape of corner is a circular arc,  $r_b$  is to be equal to  $r_a$ )

$\ell_{CD}$  = Length of cross deck, in m, in longitudinal direction

$b$  = Distance, in m, from the edge of hatch opening to the ship's side.

## APPENDIX 1 CROSS SECTIONAL PROPERTIES FOR TORSION

### 1 Calculation Formulae

#### 1.1 Torsion Function $\Phi$

##### 1.1.1

For any partial area of closed cells the following geometric figures and ratios have to be computed:

$$A_y = \frac{1}{2}(z_i + z_k)(y_k - y_i)$$

$$l = \sqrt{(y_k - y_i)^2 + (z_k - z_i)^2}$$

$$\frac{s}{t} = \frac{\ell}{t}$$

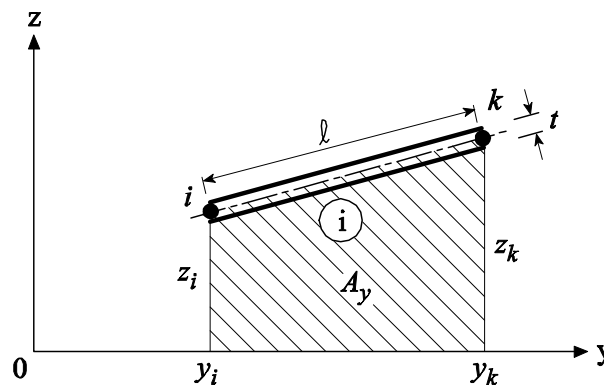

Fig. 1

The following three versions of algorithms may be applied depending on the type of cross section:

**Version A:** Asymmetric open cross sections as shown in Fig 2

**Version B:** Symmetric cross sections with particular closed cells (closed cells without shared walls) as shown in Fig 3. In this case the torsion function can be calculated for each cell separately.

$$\Phi_0 = \frac{2 \sum_{Cell\ 0} A_y}{\sum_{Cell\ 0} \frac{s}{t}} \quad ; \quad \Phi_2 = \frac{2 \sum_{Cell\ 2} A_y}{\sum_{Cell\ 2} \frac{s}{t}}$$

**Version C:** Symmetric cross sections with multiple closed cells (closed cells with shared walls) as shown in Fig 4. In this case the torsion function for each cell  $i$  can be calculated by solving a linear system of equations considering the shared walls.

$$\Phi_0 \sum_{Cell\ 0} \frac{s}{t} + \Phi_1 \left( \frac{s}{t} \right)_{Common\ Wall} = 2A_{Cell0}$$

$$\Phi_1 \sum_{Cell\ 1} \frac{s}{t} + \Phi_0 \left( \frac{s}{t} \right)_{Common\ Wall} = 2A_{Cell1}$$

From this system of equations the torsion functions  $\Phi_0$  and  $\Phi_1$  can be derived.

## 1.2 Co-ordinate system, running coordinate $s$

### 1.2.1

A 2-D cartesian co-ordinate system is to be used. The choice of the reference point O (origin of co-ordinate system) is free, but for symmetric cross sections it is advantageous to define the origin at the line of symmetry of the cross section. The running co-ordinate  $s$  starts within symmetric cross sections at the intersection of the line of symmetry with the cross section geometry, e.g. in hull cross sections at the intersection of centreline and bottom shell or double-bottom as indicated by '0' in Fig 2 to Fig 4. The orientation of  $s$  as well as the direction of integration within closed cells is to be considered with respect to the algebraic signs and the assembly of the system of equations for the torsion function.

## 1.3 Computation of several properties for each part of the cross section

### 1.3.1

$\omega_i$  =  $\omega_k$  of the preceding partial area or of the preceding point of bifurcation. (to be set equal to zero at the beginning of the computation)

$\omega_k$  =  $\omega_i + y_i z_k - y_k z_i - \Phi \frac{\ell_i}{t_i}$ , with  $\Phi \frac{\ell_i}{t_i}$  within closed cells

$$\ell_i = \sqrt{(y_k - y_i)^2 + (z_k - z_i)^2}$$

	Summation
$A$ = $\ell t$	$\sum A$
$S_y$ = $A/2(z_i + z_k)$	$\sum S_y$
$S_z$ = $A/2(y_i + y_k)$	$\sum S_z$
$S_\omega$ = $A/2(\omega_i + \omega_k)$	$\sum S_\omega$
$I_y$ = $A/3(z_i^2 + z_i z_k + z_k^2)$	$\sum I_y$
$I_z$ = $A/3(y_i^2 + y_i y_k + y_k^2)$	$\sum I_z$
$I_{yz}$ = $A/6[(2y_k + y_i)z_k + (2y_i + y_k)z_i]$	$\sum I_{yz}$
$I_\omega$ = $A/3(\omega_i^2 + \omega_i \omega_k + \omega_k^2)$	$\sum I_\omega$
$I_{\omega y}$ = $A/6[(2y_k + y_i)\omega_k + (2y_i + y_k)\omega_i]$	$\sum I_{\omega y}$
$I_{\omega z}$ = $A/6[(2z_k + z_i)\omega_k + (2z_i + z_k)\omega_i]$	$\sum I_{\omega z}$
$s t^3$ = $\ell t^3$	$\sum s \cdot t^3$

### 1.4 Computation of cross sectional properties for the entire cross section

<i>Asymmetric cross section:</i>	<i>Symmetric cross section (only half of the section is modeled)</i>
$A = \sum A$	$A = 2 \sum A$
$y_s = \frac{\sum S_z}{\sum A}$	$y_s = \frac{\sum S_z}{\sum A}$
$z_s = \frac{\sum S_y}{\sum A}$	$z_s = \frac{\sum S_y}{\sum A}$
$I_y = \sum I_y - \sum A z_s^2$	$I_y = 2 \left( \sum I_y - \sum A z_s^2 \right)$
$I_z = \sum I_z - \sum A y_s^2$	$I_z = 2 \left( \sum I_z - \sum A y_s^2 \right)$
$I_{yz} = \sum I_{yz} - \sum A y_s z_s$	
$I_T = \sum \frac{S t^3}{3} + \sum_{Cell\ i} (2 A_{yi} \Phi_i)$	$I_T = 2 \left[ \sum \frac{S t^3}{3} + \sum_{Cell\ i} (2 A_{yi} \Phi_i) \right]$
$\omega_0 = \frac{\sum S_\omega}{\sum A}$	
$I_{\omega y} = \sum I_{\omega y} - \sum A y_s \omega_0$	$I_{\omega y} = 2 \sum I_{\omega y}$
$I_{\omega z} = \sum I_{\omega z} - \sum A z_s \omega_0$	
$y_M = \frac{I_{\omega z} I_z - I_{\omega y} I_{yz}}{I_y I_z - I_{yz}^2}$	
$z_M = \frac{I_{\omega z} I_{yz} - I_{\omega y} I_y}{I_y I_z - I_{yz}^2}$	$z_M = -\frac{I_{\omega y}}{I_z}$
$I_\omega = \sum I_\omega - \sum A \omega_0^2 + z_M I_{\omega y} - y_M I_{\omega z}$	$I_\omega = 2 \sum I_\omega + z_M I_{\omega y}$

$I_y, I_z, I_{yz}$  are to be computed with relation to the centre of gravity.

$S_x, S_y, S_\omega, I_{\omega y}, I_{\omega z}$  and  $I_{\omega z}$  are to be computed with relation to shear centre  $M$

The sector-coordinate  $\omega$  has to be transformed with respect to the location of the shear centre  $M$ . For cross sections of type **A**,  $\omega_0$  is to be added to each  $\omega_i$  and  $\omega_k$  as defined in [1.3]

For cross sections of type **B** and **C**,  $\Delta\omega$  can be calculated as follows:

$$\Delta\omega_i = z_M y_i$$

where:

$\omega_O$  = Calculated sector co-ordinate with respect to the centre of the coordinate system (O) selected for the calculation according to the formulae for given in [1.3]

$\omega$  = Transformed sector co-ordinate with respect to shear centre  $M$

$y_M, z_M$  = Distance between shear centre  $M$  and centre of the coordinate system B.

The transformed values of  $\omega$  can be obtained by adding  $\Delta\omega$  to the values of  $\omega_O$  obtained according to the formulae in [1.3].

The transformed value for  $\omega$  is to be equal to zero at intersections of the cross section with the line of symmetry (centreline for ship-sections).

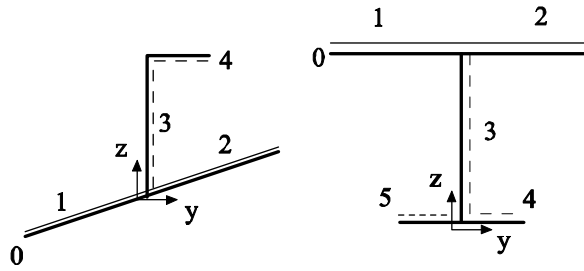

Fig. 2  
 Cross sections of type A

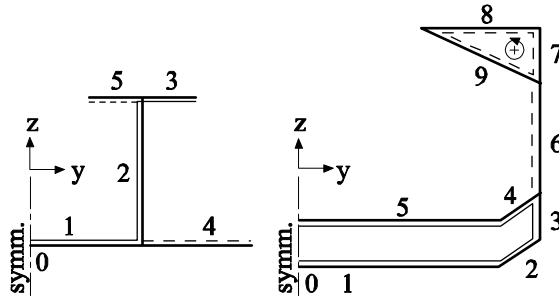
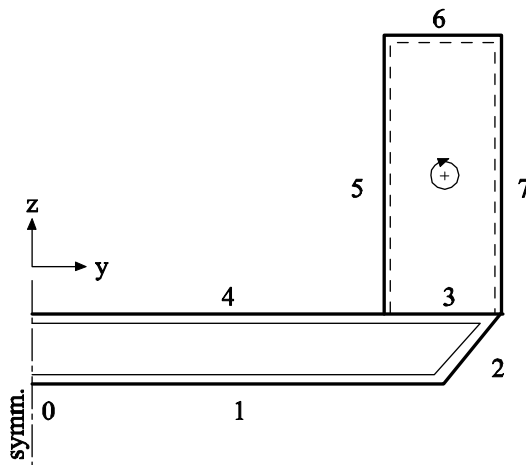

Fig. 3  
 Cross sections of type B



	Main Line
	1. Byline
	2. Byline

Fig. 4  
 Cross section of type C

Designation of line types (numbers at particular parts of cross sections) gives the order of the particular parts for the calculation and therefore the direction of the running coordinate  $s$ .



## 2 Example calculation for a single side hull cross section

### 2.1 Cross section data

#### 2.1.1

The cross section is shown in Fig 5. The co-ordinates of the node-points marked by filled black circles in Fig 5 are given in the Table 1, where the plate thicknesses and the line segments (marked by circles in Fig 5) of the cross section are given in Table 2.

Node number	Y Coordinate	Z Coordinate
0	0.00	0.00
1	14.42	0.00
2	16.13	1.72
3	16.13	6.11
4	11.70	1.68
5	0.00	1.68
6	16.13	14.15
7	16.13	19.6
8	7.50	20.25
9	7.50	19.63
10	0.00	20.25

### 2.2 Determination of the torsion function $\Phi$

#### 2.2.1

The first step is to build a linear system of equation for the determination of the torsion function  $\Phi$  of each closed cell. The cross section and the cells are shown in Fig 5.

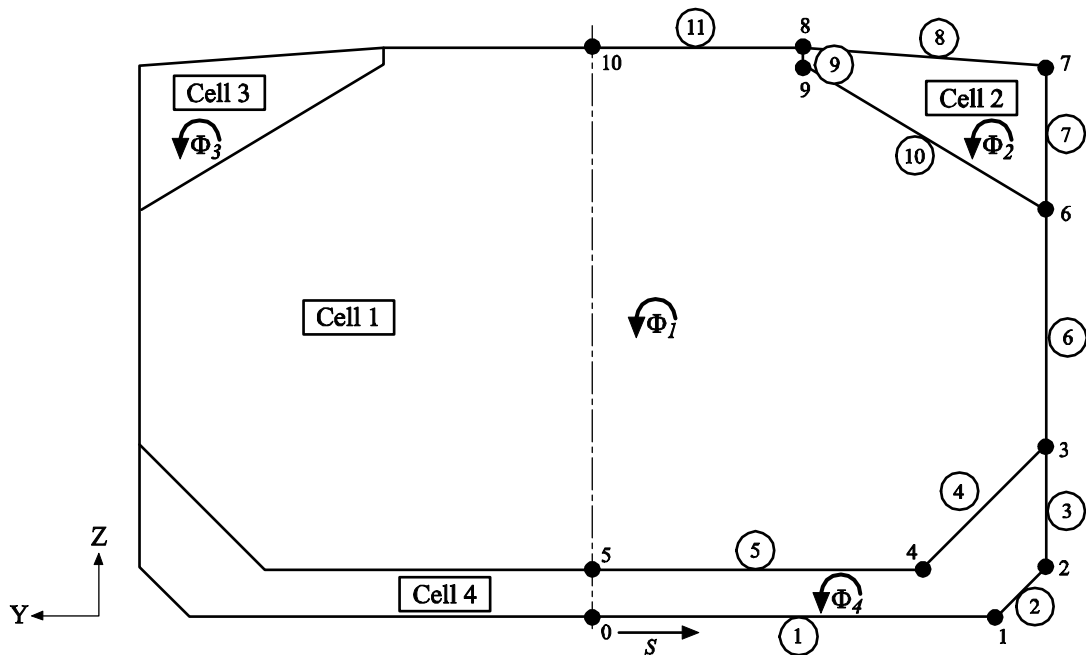

Fig. 5  
Single side hull cross section

**Table 2 Dimensions and nodes of line segments of the cross section**

Line-No.	Node <i>i</i>	Node <i>k</i>	<i>y<sub>i</sub></i>	<i>z<sub>i</sub></i>	<i>y<sub>k</sub></i>	<i>z<sub>k</sub></i>	Length	Thickness
1	0	1	0.00	0.00	14.42	0.00	14.42	0.017
2	1	2	14.42	0.00	16.13	1.72	2.43	0.017
3	2	3	16.13	1.72	16.13	6.11	4.39	0.018
4	3	4	16.13	6.11	11.70	1.68	6.26	0.019
5	4	5	11.70	1.68	0.00	1.68	11.70	0.021
6	3	6	16.13	6.11	16.13	14.15	8.04	0.018
7	6	7	16.13	14.15	16.13	19.6	5.45	0.021
8	7	8	16.13	19.60	7.50	20.25	8.65	0.024
9	8	9	7.50	20.25	7.50	19.63	0.62	0.024
10	9	6	7.50	19.63	16.13	14.15	10.22	0.015
11	8	10	7.50	20.25	0.00	20.25	7.50	0.012

Under consideration of the 4 cells (marked by rectangles in Fig 5) of the cross section, the following system of equation for the determination of the torsion function  $\Phi$  can be developed. It should be noted that the direction of the rotation is to be considered (the rotation directions for the torsion functions  $\Phi_i$  should point in the same direction for all  $\Phi_i$  to build up the system of equations).

$$\begin{aligned}
 \sum_1 \frac{s}{t} \Phi_1 - \sum_{1-2} \frac{s}{t} \Phi_2 - \sum_{1-3} \frac{s}{t} \Phi_3 - \sum_{1-4} \frac{s}{t} \Phi_4 &= 2 \sum_1 A \\
 -\sum_{1-2} \frac{s}{t} \Phi_1 + \sum_2 \frac{s}{t} \Phi_2 &= 2 \sum_2 A \\
 -\sum_{1-3} \frac{s}{t} \Phi_1 + \sum_3 \frac{s}{t} \Phi_3 &= 2 \sum_3 A \\
 -\sum_{1-4} \frac{s}{t} \Phi_1 + \sum_4 \frac{s}{t} \Phi_4 &= 2 \sum_4 A
 \end{aligned}$$

The coefficients of the matrix can be calculated as follows:

$$\sum_1 \frac{s}{t} = \frac{2 \cdot 11700}{21} + \frac{2 \cdot 6265}{19} + \frac{2 \cdot 8040}{18} + \frac{2 \cdot 10223}{15} + \frac{2 \cdot 620}{24} + \frac{2 \cdot 7500}{12} = 5331.81$$

$$\sum_2 \frac{s}{t} = \frac{10223}{15} + \frac{5450}{21} + \frac{620}{24} + \frac{8654}{24} = 1327.48$$

$$\sum_3 \frac{s}{t} = 1327.48$$

$$\sum_4 \frac{s}{t} = \frac{2 \cdot 14420}{17} + \frac{2 \cdot 11700}{21} + \frac{2 \cdot 6265}{19} + \frac{2 \cdot 2425}{17} + \frac{2 \cdot 4390}{18} = 4243.34$$

$$\sum_{1-2} \frac{s}{t} = \frac{10223}{15} + \frac{620}{24} = 707.36$$

$$\sum_{1-3} \frac{s}{t} = 707.36$$

$$\sum_{1-4} \frac{s}{t} = \frac{2 \cdot 11700}{21} + \frac{2 \cdot 6265}{19} = 1773.76$$

The areas of the cells can be calculated as follows:

$$2 \sum_1 A = 2 \cdot 2 \cdot 260.72 = 1042.90 \text{ m}^2$$

$$2 \sum_2 A = 2 \cdot 26.19 = 52.38 \text{ m}^2$$

$$2 \sum_3 A = 52.38 \text{ m}^2$$

$$2 \sum_4 A = 2 \cdot 2 \cdot 35.44 = 141.76 \text{ m}^2$$

With these results the coefficient matrix will become:

$$\begin{array}{rclcl} 5331.81\Phi_1 & -707.36\Phi_2 & -707.36\Phi_3 & -1773.76\Phi_4 & = 1042.90 \\ -707.36\Phi_1 & +1327.48\Phi_2 & & & = 52.38 \\ -707.36\Phi_1 & & +1327.48\Phi_3 & & = 52.38 \\ -1773.76\Phi_1 & & & +4243.34\Phi_4 & = 141.76 \end{array}$$

The solution of this system gives:

$$\Phi_1 = 0.3018$$

$$\Phi_2 = 0.2003$$

$$\Phi_3 = 0.2003$$

$$\Phi_4 = 0.1596$$

## 2.3 Determination of the line-segment properties

### 2.3.1

The next step is the determination of  $w_k$  according to the formulae given in [1.3]. 's' starts at point 0 (Fig 5) with  $w_i=0$  and follows the path from point 0 to point 1, 2, 3, 4 up to point 5. It is to be noted, that the term

$$\Phi \left( \frac{\ell_i}{t_i} \right)$$

is for the line segments 1 to 3 (between points 0 and 3) calculated as

$$\Phi_4 \left( \frac{\ell_{1..3}}{t_{1..3}} \right)$$

where for the line segments 4 and 5 this term becomes

$$(\Phi_4 - \Phi_1) \left( \frac{\ell_{4..5}}{t_{4..5}} \right)$$

because line segments 4 and 5 are shared walls of cell 4 and cell 1. The rotation direction for the torsion functions together with the direction of integration (direction of path, which one follows for the calculation) determines the algebraic sign within this term.

For the line segment 6  $w_i$  has to be set to the value at point 3 and

$$\Phi\left(\frac{\ell_i}{t_i}\right) = \Phi_1\left(\frac{\ell_6}{t_6}\right).$$

's' follows now the path from point 6 to point 7, 8, 9 back to point 6. The shared wall between cell 2 and cell 1 has to be considered for the terms which include the torsion function  $\Phi$ . For the line segment 11 between point 8 and 10,  $w_i$  has to be set to the value at point 8.

The other properties of the line segments can be calculated by the formulas given in [1.3].

## 2.4 Determination of cross-section properties

### 2.4.1

After the summation of the line-segment properties, the cross section properties can be calculated as described in [1.4].

The sector coordinate has to be transformed with respect to the shear centre as described in [1.4]

The result of the calculations gives the sector co-ordinates, as indicated in Table 3.

Point $i$	$\omega_{O,i}$	$\Delta\omega_i$	$\omega_i$
0	0.00	0.00	0.00
1	-135.97	84.99	-50.98
2	-134.04	95.07	-38.97
3	-102.32	95.07	-7.25
4	-99.49	68.96	-30.53
5	-0.06	0.00	-0.06
6	-108.20	95.07	-13.13
7	-72.30	95.07	22.77
8	35.07	44.21	79.27
9	33.08	44.21	77.28
10	-2.75	0.00	-2.75

## 2.5 Notes

### 2.5.1

For single side bulk carrier, the hull cross section normally can be simplified in a section with four boxes (cell 1 cargo hold, cell 2 and 3 wing tanks and cell 4 hopper tanks and double bottom as shown in the calculation example) whereas the cross section of a double side bulk carrier can be simplified to a cross section with two closed cells only (cell 1 cargo hold, cell 2 double hull). For the plate thickness of the line elements with variable thicknesses an equivalent plate thickness can be used calculated by the following formulae:

$$t_{eq} = \frac{t_1\ell_1 + t_2\ell_2 + \dots + t_i\ell_i + \dots + t_k\ell_k}{\sum_{i=1}^k \ell_i}$$

Due to the simplifications, the value of the sector co-ordinate  $w$  can differ from 0 at the intersections between the cross section and centreline. The difference between the value of the sector co-ordinate  $w$  and the value of the torsional moment of inertia  $I_T$  for the simplified cross section is in normal cases less than 3% compared to the values of the original cross section.

# **Chapter 9**

## **Other Structures**

---

Section 1 Fore Part

Section 2 Aft Part

Section 3 Machinery Space

Section 4 Superstructures and Deckhouses

Section 5 Hatch Covers

Section 6 Arrangement of Hull and Superstructure Openings



## SECTION 1 FORE PART

### Symbols

For symbols not defined in this Section, refer to Ch 1, Sec 4.

$L_2$  = Rule length  $L$ , but to be taken not greater than 300 m

$T_B$  = Minimum ballast draught, in m, for normal ballast conditions

$k$  = Material factor, defined in Ch 3, Sec 1, [2.2]

$m$  = Coefficient taken equal to:

$m = 10$  for vertical stiffeners

$m = 12$  for other stiffeners

$\tau_a$  = Allowable shear stress, in N/mm<sup>2</sup>, taken equal to:

$$\tau_a = \frac{R_y}{\sqrt{3}}$$

$s$  = Spacing, in m, of ordinary stiffeners, measured at mid-span along the chord

$\ell$  = Span, in m, of ordinary stiffeners, measured along the chord between the supporting members, see Ch 3, Sec 6, [4.2]

$c_a$  = Aspect ratio of the plate panel, equal to:

$$c_a = 1.21 \sqrt{1 + 0.33 \left(\frac{s}{\ell}\right)^2} - 0.69 \frac{s}{\ell}$$

to be taken not greater than 1.0

$c_r$  = Coefficient of curvature of the panel, equal to:

$$c_r = 1 - 0.5 \frac{s}{r}$$

to be taken not less than 0.4

$r$  = Radius of curvature, in m.

## 1 General

### 1.1 Application

#### 1.1.1

The requirement of this Section apply to:

- the structures located forward of the collision bulkhead, i.e.:
  - the fore peak structures
  - the stem
- the reinforcements of the bow flare area, according to [4.1]
- the reinforcements of the flat bottom forward area, according to [5.1].

### 1.2 Net thicknesses

#### 1.2.1

As specified in Ch 3, Sec 2, all thicknesses referred to in this Section are net, i.e. they do not include any corrosion addition. The gross thicknesses are to be obtained as specified in Ch 3, Sec 2, [3].

## 2 Arrangement

### 2.1 Structural arrangement principles

#### 2.1.1 General

Scantlings of the shell envelope, upper deck and inner bottom, if any, are to be tapered towards the forward end. Special consideration is to be paid to the structural continuity of major longitudinal members in order to avoid abrupt changes in section.

Structures within the fore peak, such as platforms, decks, horizontal ring frames or side stringers are to be scarphed into the structure aft into the cargo hold.

Where inner hull structures terminate at the collision bulkhead, the structural continuity is to be ensured forward of the collision bulkhead by adequate structure with tapering brackets.

Longitudinal stiffeners of deck, bottom and side shell are to be extended as far forward as practicable.

All shell frames and tank boundary stiffeners are to be continuous, or are to be bracketed at their ends.

Where the brackets are provided to ensure the structural continuity from the forward end to  $0.15L$  behind fore perpendicular, flanged brackets have to be used.

#### 2.1.2 Structures in tanks

Where peaks are used as tanks, stringer plates are to be flanged or face bars are to be fitted at their inner edges. Stringers are to be effectively fitted to the collision bulkhead so that the forces can be properly transmitted.

### 2.2 Tripping brackets

#### 2.2.1

For peaks or other tanks forward of the collision bulkhead transversely framed, tripping brackets vertically spaced not more than 2.6 m are to be fitted, according to Fig 1, between primary supporting members, decks and/or platforms.

The as-built thickness of the tripping brackets is to be not less than the as-built thickness of the side frame webs to which they are connected.

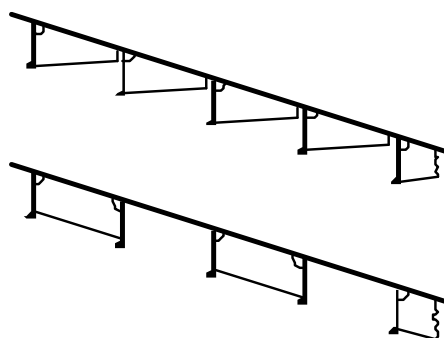

Fig. 1  
Tripping brackets

### 2.3 Floors and bottom girders

#### 2.3.1

Where no centreline bulkhead is provided, a centre bottom girder is to be fitted.

In general, the minimum depth of the floor at the centerline and center girders is to be not less than the required depth of the double bottom of the foremost cargo hold.

#### 2.3.2 Solid floors

In case of transverse framing, solid floors are to be fitted at every frame.

In case of the longitudinal framing, the spacing of solid floors is not to be greater than 3.5 m or four transverse frame spaces, whichever is the smaller.

#### 2.3.3 Bottom girders

In case of transverse framing, the spacing of bottom girders is not to exceed 2.5 m.



In case of longitudinal framing, the spacing of bottom girders is not to exceed 3.5 m.

### 3 Load model

#### 3.1 Load point

##### 3.1.1

Unless otherwise specified, lateral pressure is to be calculated at load points according to:

- Ch 6, Sec 1, [1.5], for plating
- Ch 6, Sec 2, [1.4], for stiffeners.

#### 3.2 Pressure in bow area

##### 3.2.1 Lateral pressure in intact conditions

The pressure in bow area, in  $\text{kN/m}^2$ , is to be taken equal to  $(p_S + p_W)$ .

where:

$p_S, p_W$  = Hydrostatic and hydrodynamic pressures according to Ch 4, Sec 5, or internal still water and inertial pressures according to Ch 4, Sec 6, [2], to be considered among load cases H, F, R and P.

##### 3.2.2 Lateral pressure in testing conditions

The lateral pressure  $p_T$  in testing conditions is taken equal to:

$p_T = p_{ST} - p_S$  for bottom shell plating and side shell plating  
 $p_T = p_{ST}$  otherwise

where:

$p_{ST}$  = Testing pressure defined in Ch 4, Sec 6, [4]  
 $p_S$  = Pressure taken equal to:

- if the testing is carried out afloat: hydrostatic pressure defined in Ch 4, Sec 5, [1] for the draught  $T_I$ , defined by the Designer, at which the testing is carried out. If  $T_I$  is not defined, the testing is considered as being not carried out afloat.
- if the testing is not carried out afloat:  $p_S = 0$

##### 3.2.3 Elements of the outer shell

The still water and wave lateral pressures are to be calculated considering separately:

- the still water and wave external sea pressures
- the still water and wave internal pressure considering the compartment adjacent to the outer shell as being loaded. If the compartment adjacent to the outer shell is intended to carry liquids, this still water and wave internal pressures are to be reduced from the corresponding still water and wave external sea pressures.

##### 3.2.4 Elements other than those of the outer shell

The still water and wave lateral pressures to be considered as acting on an element which separates two adjacent compartments are those obtained considering the two compartments individually loaded.

#### 3.3 Bow flare area pressure

##### 3.3.1

The bow pressure  $p_{FB}$ , in  $\text{kN/m}^2$ , is to be obtained according to Ch 4, Sec 5, [4.1].

#### 3.4 Bottom slamming pressure

##### 3.4.1

The bottom slamming pressure  $p_{SL}$ , in  $\text{kN/m}^2$ , in the flat bottom forward is to be obtained according to Ch 4, Sec 5, [4.2].

## 4 Scantlings

### 4.1 Bow flare reinforcement

#### 4.1.1

The bow flare area to be reinforced is that extending forward of  $0.9L$  from the aft end and above the normal ballast waterline according to the applicable requirements in [4.2] to [4.4].

### 4.2 Plating

#### 4.2.1

The net thickness of plating are to be not less than those obtained from the formulae in Table 1 and Table 2.

<b>Table 1 Net minimum thickness of plating</b>	
<i>Minimum net thickness, in mm</i>	
Bottom,	$5.5 + 0.03L$
Side	$0.85L^{1/2}$
Inner bottom	$5.5 + 0.03L$
Strength deck	$4.5 + 0.02L$
Platform and wash bulkhead	6.5

<b>Table 2 Net thickness of plating</b>	
<i>Net thickness, in mm</i>	
Intact conditions	$t = 15.8c_a c_r s \sqrt{\frac{P_S + P_W}{0.9R_Y}}$
Bow flare area	$t = 15.8c_a c_r s \sqrt{\frac{P_{FB}}{0.9R_Y}}$
Testing conditions	$t = 15.8c_a c_r s \sqrt{\frac{P_T}{1.05R_Y}}$

### 4.3 Ordinary stiffeners

#### 4.3.1 General

The requirements of this sub-article apply to ordinary stiffeners considered as clamped at both ends. For other boundary conditions, the yielding check is to be considered on a case by case basis.

#### 4.3.2

The net dimensions of ordinary stiffeners are to comply with the requirements in Ch 6, Sec 2, [2.3]

#### 4.3.3

The net thickness of the web of ordinary stiffeners, in mm, is to be not less than the greater of:

- $t = 3.0 + 0.015L_2$
- 40% of the net required thickness of the attached plating, to be determined according to [4.2] and [5.2].

The net dimensions of ordinary stiffeners are to comply with the requirement in Ch 6, Sec 2, [2.2.2] and [2.3].

#### 4.3.4

The net scantlings of single-span ordinary stiffeners are to be not less than those obtained from the formulae in

Table 3.

<b>Table 3 Net scantlings of single span ordinary stiffeners</b>		
<i>Stiffener type</i>	<i>Net section modulus <math>w</math>, in <math>cm^3</math></i>	<i>Net sectional shear area <math>A_{sh}</math>, in <math>cm^2</math></i>
Single span ordinary stiffeners subjected to lateral pressure	$w = \frac{(p_S + p_W)s\ell^2}{0.9mR_Y} 10^3$	$A_{sh} = \frac{5(p_S + p_W)s\ell}{\tau_a \sin \phi}$
Single span ordinary stiffeners located in bow flare area	$w = \frac{p_{FB}s\ell^2}{0.9mR_Y} 10^3$	$A_{sh} = \frac{5p_{FB}s\ell}{\tau_a \sin \phi}$
Single span ordinary stiffeners subjected to testing pressure	$w = \frac{p_Ts\ell^2}{1.05mR_Y} 10^3$	$A_{sh} = \frac{5p_Ts\ell}{1.05\tau_a \sin \phi}$
where: $\phi$ = Angle, in deg, between the stiffener web and the shell plate, measured at the middle of the stiffener span; the correction is to be applied when $\phi$ is less than 75.		

### 4.3.5

The maximum normal stress  $\sigma$  and shear stress  $\tau$  in a multi-span ordinary stiffener are to comply with the formulae in Table 4.

The maximum normal stress  $\sigma$  and shear stress  $\tau$  in a multi-span ordinary stiffener are to be determined by a direct calculation taking into account:

- the distribution of still water and wave pressure and forces, if any
- the number and position of intermediate supports (decks, girders, etc.)
- the condition of fixity at the ends of the stiffener and at intermediate supports
- the geometrical characteristics of the stiffener on the intermediate spans.

<b>Table 4 Checking criteria for multi-span ordinary stiffeners</b>		
<i>Condition</i>	<i>Intact</i>	<i>Testing</i>
Normal stress	$\sigma \leq 0.9R_Y$	$\sigma \leq 1.05R_Y$
Shear stress	$\tau \leq \tau_a$	$\tau \leq 1.05\tau_a$

## 4.4 Primary supporting members

### 4.4.1 Minimum thickness

The net thickness of the web of primary supporting members, in mm, is to be not less than that obtained from the following formula:

$$t = 0.7\sqrt{L_2}$$

### 4.4.2 Side transverses

The net section modulus  $w$ , in  $cm^3$ , and the net shear sectional area  $A_{sh}$ , in  $cm^2$ , of side transverses are to be not less than the values obtained from the following formulae:

$$w = \frac{(p_S + p_W)s\ell^2}{0.9mR_Y} 10^3$$

$$A_{sh} = \frac{5(p_S + p_W)s\ell}{\tau_a \sin \phi}$$

In addition, the net section modulus  $w$ , in  $cm^3$ , and the net shear sectional area  $A_{sh}$ , in  $cm^2$ , of side transverses located within the bow flare area are to be not less than the values obtained from the following formulae:

$$w = \frac{p_{FB} s \ell^2}{0.9 m R_Y} 10^3$$

$$A_{sh} = \frac{5 p_{FB} s \ell}{\tau_a \sin \phi}$$

#### 4.4.3 Side girders

The net section modulus  $w$ , in  $\text{cm}^3$ , and the net shear sectional area  $A_{sh}$ , in  $\text{cm}^2$ , of side girders are to be not less than the values obtained from the following formulae:

$$w = \frac{(p_S + p_W) s \ell^2}{0.9 m R_Y} 10^3$$

$$A_{sh} = \frac{5(p_S + p_W) s \ell}{\tau_a \sin \phi}$$

In addition, the net section modulus  $w$ , in  $\text{cm}^3$ , and the net shear sectional area  $A_{sh}$ , in  $\text{cm}^2$ , of side girders located within the bow flare area are to be not less than the values obtained from the following formulae:

$$w = \frac{p_{FB} s \ell^2}{0.9 m R_Y} 10^3$$

$$A_{sh} = \frac{5 p_{FB} s \ell}{\tau_a \sin \phi}$$

#### 4.4.4 Deck primary supporting members

Scantlings of deck primary supporting members are to be in accordance with Ch 6, Sec 4, considering the loads in [3.2] and [3.3].

## 5 Strengthening of flat bottom forward area

### 5.1 Application

#### 5.1.1

The flat bottom forward area to be reinforced is the flat part of the ship's bottom extending forward of  $0.2V\sqrt{L}$  from the fore perpendicular end, up to a height of  $0.05T_B$  or 0.3 m above base line, whichever is the smaller.

### 5.2 Bottom plating

#### 5.2.1

The net thickness, in mm, of the flat bottom forward area, is not to be less than:

$$t = 15.8 C_a C_r s \sqrt{\frac{C_s p_{SL}}{R_{eH}}}$$

where:

$C_s$  = Coefficient relating to load patch of impact pressure, taken equal to:

$C_s = 1.0$ , where no intermediate longitudinals is provided between ordinary stiffeners

$C_s = 1.3$ , where intermediate longitudinals are provided between ordinary stiffeners.

### 5.2.2

For ships with a rise of floor the strengthened plating must at least extend to the bilge curvature.

## 5.3 Ordinary stiffeners

### 5.3.1

The net section modulus, in cm<sup>3</sup>, of transverse or longitudinal ordinary stiffeners of the flat bottom forward area is not to be less than:

$$w = \frac{C_s p_{SL} S \ell^2}{16 R_{eH}} 10^3$$

where:

$C_s$  = Coefficient defined in [5.2.1].

### 5.3.2

The net shear area, in cm<sup>2</sup>, of transverse or longitudinal ordinary stiffeners of the flat bottom forward area is not to be less than:

$$A = \frac{5\sqrt{3} p_{SL} S (\ell - 0.5s)}{R_{eH} \sin \phi}$$

The area of the welded connection has to be at least twice this value.

## 5.4 Primary supporting members

### 5.4.1 Girders

The net thickness of girders in double bottom forward area, in mm, is not to be less than the greatest of either of the value  $t_1$  to  $t_3$  specified in the followings according to each location:

$$t_1 = \frac{c_A p_{SL} S \ell}{2(d_0 - d_1) \tau_a}$$

$$t_2 = 1.75 \sqrt[3]{\frac{H^2 a^2 \tau_a}{C_1}} t_1$$

$$t_3 = \frac{C_1'' a}{\sqrt{k}}$$

where:

$c_A$  = Coefficient taken equal to:

$$c_A = 3/A, \text{ with } 0.3 \leq c_A \leq 1.0$$

$A$  = Loaded area, in m<sup>2</sup>, between the supports of the structure considered, obtained from the following formula:

$$A = S \ell$$

$p_{SL}$  = As defined in [3.4]

$S$  = Spacing of centre or side girders under consideration, in m

$\ell$  = Span of centre or side girders between floors under consideration, in m

$d_0$  = Depth of the centre or side girder under consideration, in m

$d_1$  = Depth of the opening, if any, at the point under consideration, in m

$H$  = Value obtained from the following formulae:

a) Where the girder is provided with an unreinforced opening :

$$H = 1 + 0.5 \frac{\phi}{\alpha}$$

b) In other cases:

$$H = 1.0$$

- $\phi$  = Major diameter of the openings, in m  
 $\alpha$  = The greater of  $a$  or  $S_1$ , in m.  
 $a$  = Depth of girders at the point under consideration, in m, Where, however, if horizontal stiffeners are fitted on the girder,  $a$  is the distance from the horizontal stiffener under consideration to the bottom shell plating or inner bottom plating, or the distance between the horizontal stiffeners under consideration  
 $S_1$  = Spacing, in m, of vertical ordinary stiffeners or floors  
 $C_1'$  = Coefficient obtained from Table 5 depending on  $S_1/a$ . For intermediate values of  $S_1/a$ ,  $C_1'$  is to be determined by linear interpolation.  
 $C_1''$  = Coefficient obtained from Table 6 depending on  $S_1/a$ . For intermediate values of  $S_1/a$ ,  $C_1''$  is to be obtained by linear interpolation.

$\frac{S_1}{a}$	0.3 and under	0.4	0.5	0.6	0.7	0.8	0.9	1.0	1.2	1.4 and over
$C_1'$	64	38	25	19	15	12	10	9	8	7

$\frac{S_1}{a}$	0.3 and under	0.4	0.5	0.6	0.7	0.8	0.9	1.0	1.2	1.4	1.6 and over
$C_1''$ Centre girder	4.4	5.4	6.3	7.1	7.7	8.2	8.6	8.9	9.3	9.6	9.7
$C_1''$ Side girder	3.6	4.4	5.1	5.8	6.3	6.7	7.0	7.3	7.6	7.9	8.0

#### 5.4.2 Floors

The net thickness of floors in double bottom forward area, in mm, is not to be less than the greatest of either of the value  $t_1$  to  $t_3$  specified in the followings according to each location:

$$t_1 = \frac{c_A p_{SL} S \ell}{2(d_0 - d_1) \tau_a}$$

$$t_2 = 1.75 \cdot 3 \sqrt{\frac{H^2 a^2 \tau_a}{C_2'} t_1}$$

$$t_3 = \frac{8.5 S_2}{\sqrt{k}}$$

where :

$c_A$  = Coefficient taken equal to:

$$c_A = 3/A, \text{ with } 0.3 \leq c_A \leq 1.0$$

$A$  = Loaded area, in  $m^2$ , between the supports of the structure considered, obtained from the following formula:

$$A = S \ell$$

$p_{SL}$  = As defined in [3.4]

$S$  = Spacing of floors under consideration, in m

$\ell$  = Span of floors between centre girder and side girder or side girders under consideration, in m

$d_0$  = Depth of the solid floor at the point under consideration in m

$d_1$  = Depth of the opening, if any, at the point under consideration in m

$H$  = Value obtained from the following formulae:

a) Where openings with reinforcement or no opening are provided on solid floors:

1) Where slots without reinforcement are provided:

$$H = \sqrt{4.0 \frac{d_2}{S_1} - 1.0}, \text{ without being taken less than 1.0}$$

2) Where slots with reinforcement are provided:

$$H = 1.0$$

b) Where openings without reinforcement are provided on solid floors:

1) Where slots without reinforcement are provided:

$$H = \left(1 + 0.5 \frac{\phi}{d_0}\right) \sqrt{4.0 \frac{d_2}{S_1} - 1.0}$$

without being taken less than  $1 + 0.5 \frac{\phi}{d_0}$

2) Where slots with reinforcement are provided:

$$H = 1 + 0.5 \frac{\phi}{d_0}$$

$d_2$  = Depth of slots without reinforcement provided at the upper and lower parts of solid floors, in m, whichever is greater

$S_1$  = Spacing, in m, of vertical ordinary stiffeners or girders

$\phi$  = Major diameter of the openings, in m

$a$  = Depth of the solid floor at the point under consideration, in m, Where, however, if horizontal stiffeners are fitted on the floor,  $a$  is the distance from the horizontal stiffener under consideration to the bottom shell plating or the inner bottom plating or the distance between the horizontal stiffeners under consideration

$S_2$  = The smaller of  $S_1$  or  $a$ , in m

$C_2'$  = Coefficient given in Table 7 depending on  $S_1/d_0$ . For intermediate values of  $S_1/d_0$ ,  $C_2'$  is to be determined by linear interpolation.

$S_1/d_0$	0.3 and under	0.4	0.5	0.6	0.7	0.8	0.9	1.0	1.2	1.4 and over
$C_2'$	64	38	25	19	15	12	10	9	8	7

## 6 Stem

### 6.1 Bar stem

#### 6.1.1

The gross cross sectional area, in  $\text{cm}^2$ , of a bar stem below the load waterline is not to be less than:  $A_b = 1.25L$ .

#### 6.1.2

Starting from the load waterline, the cross sectional area of the bar stem may be reduced towards the upper end to  $0.75A_b$ .

### 6.2 Plate stem and bulbous bows

#### 6.2.1

The gross thickness, in mm, is not to be less than the values obtained from the following formula:

$$t = (0.6 + 0.4s_B)(0.08L + 6)\sqrt{k}$$

without being taken greater than  $22\sqrt{k}$

where:

$s_B$  = Spacing, in m, between horizontal stringers (partial or not), breasthooks, or equivalent horizontal stiffening members.

The gross plate thickness is to be not less than the net thickness, obtained according to [4.2], plus the corrosion

addition  $t_C$  as defined in Ch 3, Sec 3.

Scantlings of the ordinary stiffeners are to be determined according to [4.3].

### 6.2.2

Starting from 0.6 m above the load waterline up to  $T+C$ , the gross thickness may gradually be reduced to  $0.8t$ , where  $t$  is the gross thickness defined in [6.2.1].

### 6.2.3

Plate stems and bulbous bows must be stiffened by breasthooks and/or frames.

## 7 Forecastle

### 7.1 General

#### 7.1.1

An enclosed forecastle is to be fitted on the freeboard deck.

The aft bulkhead of the enclosed forecastle is to be fitted in way or aft of the forward bulkhead of the foremost hold, as shown in Fig 2.

However, if this requirement hinders hatch cover operation, the aft bulkhead of forecastle may be fitted forward of the forward bulkhead of the foremost cargo hold provided the forecastle length is not less than 7% of ship length for freeboard as specified in Ch 1, Sec 4, [3.2] abaft the fore side of stem.

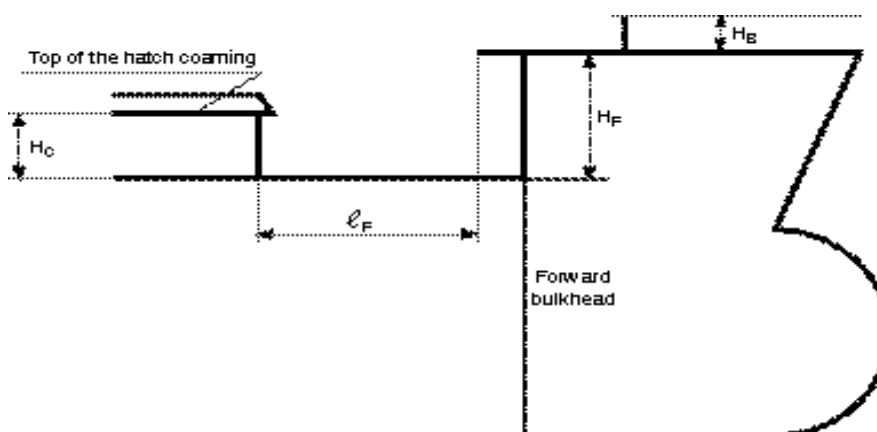

Fig. 2  
Forecastle

#### 7.1.2

The forecastle height  $H_F$  above the main deck is to be not less than the greater of the following values:

- the standard height of a superstructure as specified in Ch 1, Sec 4, [3.18]
- $H_C + 0.5$  m, where  $H_C$  is the height of the forward transverse hatch coaming of the foremost cargo hold, i.e. cargo hold No.1.

#### 7.1.3

All points of the aft edge of the forecastle deck are to be located at a distance less than or equal to  $l_F$ :

$$l_F = 5\sqrt{H_F - H_C}$$

from the hatch coaming plate in order to apply the reduced loading to the No.1 forward transverse hatch coaming and No.1 hatch cover in applying Ch 9, Sec 5, [6.2.2] and Ch 9, Sec 5, [7.3.8].

#### 7.1.4

A breakwater is not to be fitted on the forecastle deck with the purpose of protecting the hatch coaming or hatch covers. If fitted for other purposes, it is to be located such that its upper edge at centreline is not less than  $H_B / \tan 20^\circ$  forward of the aft edge of the forecastle deck, where  $H_B$  is the height of the breakwater above the forecastle (see Fig 2).



## SECTION 2 AFT PART

### Symbols

For symbols not defined in this Section, refer to Ch 1, Sec 4.

$L_1$  = Rule length  $L$ , but to be taken not greater than 200 m

$L_2$  = Rule length  $L$ , but to be taken not greater than 300 m

$k$  = Material factor, defined in Ch 3, Sec 1, [2.2]

$z_{TOP}$  =  $Z$  co-ordinate, in m, of the top of the tank

$m$  = Coefficient taken equal to:  
 $m = 10$  for vertical stiffeners  
 $m = 12$  for other stiffeners

$\tau_a$  = Allowable shear stress, in  $N/mm^2$ , taken equal to:

$$\tau_a = \frac{R_y}{\sqrt{3}}$$

$s$  = Spacing, in m, of ordinary stiffeners, measured at mid-span along the chord

$\ell$  = Span, in m, of ordinary stiffeners, measured along the chord between the supporting members, see Ch 3, Sec 6, [4.2]

$c_a$  = Aspect ratio of the plate panel, equal to:

$$c_a = 1.21 \sqrt{1 + 0.33 \left(\frac{s}{\ell}\right)^2} - 0.69 \frac{s}{\ell}$$

to be taken not greater than 1.0

$c_r$  = Coefficient of curvature of the panel, equal to:

$$c_r = 1 - 0.5 \frac{s}{r}$$

to be taken not less than 0.4

$r$  = Radius of curvature, in m.

## 1 General

### 1.1 Introduction

#### 1.1.1

The requirements of this Section apply for the scantlings of structures located aft of the aft peak bulkhead and for the reinforcements of the flat bottom aft area.

#### 1.1.2

Aft peak structures which form the boundary of spaces not intended to carry liquids, and which do not belong to the outer shell, are to be subjected to lateral pressure in flooding conditions. Their scantlings are to be determined according to the relevant criteria in Ch 6.

### 1.2 Connections of the aft part with structures located fore of the aft peak bulkhead

#### 1.2.1 Tapering

Adequate tapering is to be ensured between the scantlings in the aft part and those fore of the aft peak bulkhead. The tapering is to be such that the scantling requirements for both areas are fulfilled.

### 1.3 Net scantlings

#### 1.3.1

As specified in Ch 3, Sec 2, all thicknesses referred to in this Section are net, i.e. they do not include any corrosion addition. The gross thicknesses are to be obtained as specified in Ch 3, Sec 2, [3].

## 2 Load model

### 2.1 Load point

#### 2.1.1

Unless otherwise specified, lateral pressure is to be calculated at load points according to:

- Ch 6, Sec 1, [1.5], for plating
- Ch 6, Sec 2, [1.4], for stiffeners.

### 2.2 Lateral pressures

#### 2.2.1 Lateral pressure in intact conditions

The aft part lateral pressure in intact conditions, in  $\text{kN/m}^2$ , is to be taken equal to  $(p_S + p_W)$ .

where:

$p_S, p_W$ ) = Hydrostatic and hydrodynamic pressures according to Ch 4, Sec 5, or internal still water and inertial pressures according to Ch 4, Sec 6, [2], to be considered among load cases H, F, R and P.

#### 2.2.2 Lateral pressure in testing conditions

The lateral pressure  $p_T$  in testing conditions is taken equal to:

$$p_T = p_{ST} - p_S \quad \text{for bottom shell plating and side shell plating}$$
$$p_T = p_{ST} \quad \text{otherwise}$$

where:

$p_{ST}$  = Testing pressure defined in Ch 4, Sec 6, [4]

$p_S$  = Pressure taken equal to:

- if the testing is carried out afloat: hydrostatic pressure defined in Ch 4, Sec 5, [1] for the draught  $T_I$ , defined by the Designer, at which the testing is carried out. If  $T_I$  is not defined, the testing is considered as being not carried out afloat.
- if the testing is not carried out afloat:  $p_S = 0$ .

#### 2.2.3 Elements of the outer shell

The still water and wave lateral pressures are to be calculated considering separately:

- the still water and wave external sea pressures
- the still water and wave internal pressure considering the compartment adjacent to the outer shell as being loaded. If the compartment adjacent to the outer shell is intended to carry liquids, this still water and wave internal pressures are to be reduced from the corresponding still water and wave external sea pressures.

#### 2.2.4 Elements other than those of the outer shell

The still water and wave lateral pressures to be considered as acting on an element which separates two adjacent compartments are those obtained considering the two compartments individually loaded.

## 3 Aft peak

### 3.1 Arrangement

#### 3.1.1 General

The aft peak is, in general, to be transversely framed.

#### 3.1.2 Floors

Solid floors are to be fitted at every frame spacing.

The floor height is to be adequate in relation to the shape of the hull. Where a sterntube is fitted, the floor height is to extend at least above the sterntube. Where the hull lines do not allow such extension, plates of suitable height with upper and lower edges stiffened and securely fastened to the frames are to be fitted above the sterntube.

In way of and near the rudder post, propeller post and rudder horn, floors are to be extended up to the peak tank top and are to be increased in thickness; the increase will be considered by the Society on a case by case basis, depending on the arrangement proposed.

Floors are to be provided with stiffeners located at intervals not exceeding 800 mm.

### 3.1.3 Side frames

Side frames are to be extended up to a deck located above the full load waterline.

Side frames are to be supported by one of the following types of structure:

- non-tight platforms, to be fitted with openings having a total area not less than 10% of the area of the platforms
- side girders supported by side primary supporting members connected to deck transverses.

### 3.1.4 Platforms and side girders

Platforms and side girders within the peak are to be arranged in line with those located in the area immediately forward.

Where this arrangement is not possible due to the shape of the hull and access needs, structural continuity between the peak and the structures of the area immediately forward is to be ensured by adopting wide tapering brackets.

Where the aft peak is adjacent to a machinery space whose side is longitudinally framed, the side girders in the aft peak are to be fitted with tapering brackets.

### 3.1.5 Longitudinal bulkheads

A longitudinal non-tight bulkhead is to be fitted on the centreline of the ship, in general in the upper part of the peak, and stiffened at each frame spacing.

Where either the stern overhang is very large or the maximum breadth of the space divided by watertight and wash bulkheads is greater than 20 m, additional longitudinal wash bulkheads may be required.

## 4 Scantlings

### 4.1 Plating

#### 4.1.1

The net thickness of plating are to be not less than those obtained from the formulae in Table 1 and Table 2.

<b>Table 1 Net minimum thickness of plating</b>	
<i>Minimum net thickness, in mm</i>	
Bottom	$5.5 + 0.03L$
Side and transom	$0.85L^{1/2}$
Inner bottom	$5.5 + 0.03L$
Strength deck	$4.5 + 0.02L$
Platform and wash bulkhead	6.5

<b>Table 2 Net thickness of plating</b>	
<i>Net thickness, in mm</i>	
Intact conditions	$t = 15.8c_a c_r s \sqrt{\frac{p_s + p_w}{0.9R_y}}$
Testing conditions	$t = 15.8c_a c_r s \sqrt{\frac{p_T}{1.05R_y}}$

### 4.2 Ordinary stiffeners

#### 4.2.1 General

The requirements of this sub-article apply to ordinary stiffeners considered as clamped at both ends. For other boundary conditions, the yielding check is to be considered on a case by case basis.

#### 4.2.2

The net dimensions of ordinary stiffeners are to comply with the requirements in Ch 6, Sec 2, [2.3].

#### 4.2.3

The net thickness of the web of ordinary stiffeners, in mm, is to be not less than the greater of:

- $t = 3.0 + 0.015L_2$
- 40% of the net required thickness of the attached plating, to be determined according to [4.1].

The net dimensions of ordinary stiffeners are to comply with the requirement in Ch 6, Sec 2, [2.2.2] and [2.3].

#### 4.2.4

The net scantlings of single-span ordinary stiffeners are to be not less than those obtained from the formulae in Table 3.

<i>Stiffener type</i>	<i>Net section modulus <math>w</math>, in <math>\text{cm}^3</math></i>	<i>Net sectional shear area <math>A_{sh}</math>, in <math>\text{cm}^2</math></i>
Single span ordinary stiffeners subjected to lateral pressure	$w = \frac{(p_S + p_W)s\ell^2}{0.9mR_Y} 10^3$	$A_{sh} = \frac{5(p_S + p_W)s\ell}{\tau_a \sin \phi}$
Single span ordinary stiffeners subjected to testing pressure	$w = \frac{p_T s \ell^2}{1.05mR_Y} 10^3$	$A_{sh} = \frac{5p_T s \ell}{1.05\tau_a \sin \phi}$
where: $\phi$ = Angle, in deg, between the stiffener web and the shell plate, measured at the middle of the stiffener span; the correction is to be applied when $\phi$ is less than 75.		

#### 4.2.5

The maximum normal stress  $\sigma$  and shear stress  $\tau$  in a multi-span ordinary stiffener are to comply with the formulae in Table 4.

The maximum normal stress  $\sigma$  and shear stress  $\tau$  in a multi-span ordinary stiffener are to be determined by a direct calculation taking into account:

- the distribution of still water and wave pressure and forces, if any
- the number and position of intermediate supports (decks, girders, etc.)
- the condition of fixity at the ends of the stiffener and at intermediate supports
- the geometrical characteristics of the stiffener on the intermediate spans.

<i>Condition</i>	<i>Intact</i>	<i>Testing</i>
Normal stress	$\sigma \leq 0.9R_Y$	$\sigma \leq 1.05R_Y$
Shear stress	$\tau \leq \tau_a$	$\tau \leq 1.05\tau_a$

### 4.3 Primary supporting members

#### 4.3.1 Floors

The net thickness of floors is to be not less than that obtained, in mm, from the following formula:

$$t = 0.7\sqrt{L_2}$$

#### 4.3.2 Side transverses

The net section modulus  $w$ , in  $\text{cm}^3$ , and the net shear sectional area  $A_{sh}$ , in  $\text{cm}^2$ , of side transverses are to be not less than the values obtained from the following formulae:

$$w = \frac{(p_S + p_W)s\ell^2}{0.9mR_Y} 10^3$$

$$A_{sh} = \frac{5(p_S + p_W)s\ell}{\tau_a \sin \phi}$$

### 4.3.3 Side girders

The net section modulus  $w$ , in  $\text{cm}^3$ , and the net shear sectional area  $A_{sh}$ , in  $\text{cm}^2$ , of side girders are to be not less than the values obtained from the following formulae:

$$w = \frac{(p_S + p_W)s\ell^2}{0.9mR_Y} 10^3$$

$$A_{sh} = \frac{5(p_S + p_W)s\ell}{\tau_a \sin \phi}$$

### 4.3.4 Deck primary supporting members

Scantlings of deck primary supporting members are to be in accordance with Ch 6, Sec 4, considering the loads in [2.2].

## 5 Connection of hull structures with the rudder horn

### 5.1 Connection of aft peak structures with the rudder horn

#### 5.1.1 General

The requirement of this sub-article apply to the connection between peak structure and rudder horn where the stern-frame is of an open type and is fitted with the rudder horn.

#### 5.1.2 Rudder horn

Horn design is to be such as to enable sufficient access for welding and inspection.

The scantlings of the rudder horn, which are to comply with Ch 10, Sec 1, [9.2], may be gradually tapered inside the hull.

Connections by slot welds are not acceptable.

#### 5.1.3 Hull structures

The vertical extension of hull structure to support the rudder horn between the horn intersection with the shell and the peak tank top is in accordance with the requirements of Ch 10, Sec 1, [9.2.6] and [9.2.7].

The thickness of the structures adjacent to the rudder horn, such as shell plating, floors, platforms and side girders, the centreline bulkhead and any other structures, is to be adequately increased in relation to the horn scantlings.

### 5.2 Structural arrangement above the aft peak

#### 5.2.1 Side transverses

Where a rudder horn is fitted, side transverses, connected to deck beams, are to be arranged between the platform forming the peak tank top and the weather deck.

The side transverse spacing is to be not greater than:

- 2 frame spacings in way of the horn
- 4 frame spacings for and aft of the rudder horn
- 6 frame spacings in the area close to the aft peak bulkhead.

The side transverses are to be fitted with end brackets and located within the poop. Where there is no poop, the scantlings of side transverses below the weather deck are to be adequately increased with respect to those obtained from the formulae in [4.3.2].

#### 5.2.2 Side girders

Where the depth from the peak tank top to the weather deck is greater than 2.6 m and the side is transversely framed, one or more side girders are to be fitted, preferably in line with similar structures existing forward.

## **6 Sternframes**

### **6.1 General**

#### **6.1.1**

Sternframes may be made of cast or forged steel, with a hollow section, or fabricated from plate.

#### **6.1.2**

Cast steel and fabricated sternframes are to be strengthened by adequately spaced horizontal plates.

Abrupt changes of section are to be avoided in castings; all sections are to have adequate tapering radius.

### **6.2 Connections**

#### **6.2.1 Connection with hull structure**

Sternframes are to be effectively attached to the aft structure and the lower part of the sternframe is to be extended forward of the propeller post to a length not less than  $1500 + 6L$  mm, in order to provide an effective connection with the keel. However, the sternframe need not extend beyond the aft peak bulkhead.

The net thickness of shell plating connected with the sternframe is to be not less than that obtained, in mm, from the following formula:

$$t = 8.5 + 0.045L$$

#### **6.2.2 Connection with the keel**

The thickness of the lower part of the sternframes is to be gradually tapered to that of the solid bar keel or keel plate.

Where a keel plate is fitted, the lower part of the sternframe is to be so designed as to ensure an effective connection with the keel.

#### **6.2.3 Connection with transom floors**

Rudder posts and propeller posts are to be connected with transom floors having height not less than that of the double bottom and net thickness not less than that obtained, in mm, from the following formula:

$$t = 9 + 0.023L_f$$

#### **6.2.4 Connection with centre keelson**

Where the sternframe is made of cast steel, the lower part of the sternframe is to be fitted, as far as practicable, with a longitudinal web for connection with the centre keelson.

### **6.3 Propeller posts**

#### **6.3.1 Gross scantlings**

With reference to Ch 3, Sec 2, all scantlings and dimensions referred to in [6.3.2] to [6.3.4] are gross, i.e. they include the margins for corrosion.

#### **6.3.2 Gross scantlings of propeller posts**

The gross scantlings of propeller posts are to be not less than those obtained from the formulae in Table 5 for single screw ships and Table 6 for twin screw ships.

Scantlings and proportions of the propeller post which differ from those above may be considered acceptable provided that the section modulus of the propeller post section about its longitudinal axis is not less than that calculated with the propeller post scantlings in Table 5 or Table 6, as applicable.

#### **6.3.3 Section modulus below the propeller shaft bossing**

In the case of a propeller post without a sole piece, the section modulus of the propeller post may be gradually reduced below the propeller shaft bossing down to 85% of the value calculated with the scantlings in Table 5 or Table 6, as applicable.

In any case, the thicknesses of the propeller posts are to be not less than those obtained from the formulae in the tables.

### 6.3.4 Welding of fabricated propeller post with the propeller shaft bossing

Welding of a fabricated propeller post with the propeller shaft bossing is to be in accordance with Ch 11, Sec 2.

## 6.4 Propeller shaft bossing

### 6.4.1

In single screw ships, the thickness of the propeller shaft bossing, included in the propeller post, is to be not less than 60% of the dimension  $b$  required in [6.3.2] for bar propeller posts with a rectangular section.

Gross scantlings of propeller posts, in mm	Fabricated propeller post	Cast propeller post	Bar propeller post, cast or forged, having rectangular section
$a$	$50 L^{1/2}$	$33 L^{1/2}$	$10\sqrt{7.2L - 256}$
$b$	$35 L^{1/2}$	$23 L^{1/2}$	$10\sqrt{4.6L - 164}$
$t_1^{(1)}$	$2.5 L^{1/2}$	$3.2 L^{1/2}$ to be taken not less than 19 mm	-
$t_2^{(1)}$	-	$4.4 L^{1/2}$ to be taken not less than 19 mm	-
$t_D$	$1.3 L^{1/2}$	$2.0 L^{1/2}$	-
$R$	-	$50 L^{1/2}$	-

(1) Propeller post thicknesses  $t_1$ , and  $t_2$  are, in any case, to be not less than  $(0.05 L + 9.5)$  mm.

Gross scantlings of propeller posts, in mm	Fabricated propeller post	Cast propeller post	Bar propeller post, cast or forged, having rectangular section
$a$	$25 L^{1/2}$	$12.5 L^{1/2}$	$2.4L + 6$
$b$	$25 L^{1/2}$	$25 L^{1/2}$	$0.8L + 2$
$t_1^{(1)}$	$2.5 L^{1/2}$	$2.5 L^{1/2}$	-
$t_2^{(1)}$	$3.2 L^{1/2}$	$3.2 L^{1/2}$	-
$t_3$	-	$4.4 L^{1/2}$	-
$t_D$	$1.3 L^{1/2}$	$2.0 L^{1/2}$	-

(1) Propeller post thicknesses  $t_1$ ,  $t_2$  and  $t_3$  are, in any case, to be not less than  $(0.05L + 9.5)$  mm.

## 6.5 Sterntubes

### 6.5.1 Sterntubes

The sterntube thickness is considered by the Society on a case by case basis. In no case, however, may it be less than the thickness of the side plating adjacent to the stern-frame.

Where the materials adopted for the sterntube and the plating adjacent to the sternframe are different, the sterntube thickness is to be at least equivalent to that of the plating.

## SECTION 3 MACHINERY SPACE

### Symbols

For symbols not defined in this Section, refer to Ch 1, Sec 4.

$k$  = Material factor, defined in Ch 3, Sec 1, [2.2]

$P$  = Maximum continuous rating, in kW, of the engine

$n_r$  = Number of revolutions per minute of the engine shaft at power equal to  $P$

$L_E$  = Effective length, in m, of the engine foundation plate required for bolting the engine to the seating, as specified by the engine manufacturer.

### 1 General

#### 1.1 Application

##### 1.1.1

The requirements of this Section apply for the arrangement and scantling of machinery space structures as regards general strength. It is no substitute to machinery manufacturer's requirements that have to be dealt with at Shipyard diligence.

#### 1.2 Scantlings

##### 1.2.1 Net scantlings

As specified in Ch 3, Sec 2 all scantlings referred to in this Section are net, i.e. they do not include any margin for corrosion.

The gross scantlings are obtained as specified in Ch 3, Sec 2 [3.1].

##### 1.2.2 General

Unless otherwise specified in this Section, the scantlings of plating, ordinary stiffeners and primary supporting members in the machinery space are to be determined according to the relevant criteria in Ch 6.

In addition, the minimum thickness requirements specified in this Section apply.

##### 1.2.3 Primary supporting members

The Designer may propose arrangements and scantlings alternative to the requirements of this Section, on the basis of direct calculations which are to be submitted to the Society for examination on a case by case basis.

The Society may also require such direct calculations to be carried out whenever deemed necessary.

#### 1.3 Connections of the machinery space with structures located aft and forward

##### 1.3.1 Tapering

Adequate tapering is to be ensured between the scantlings in the machinery space and those aft and forward. The tapering is to be such that the scantling requirements for all areas are fulfilled.

##### 1.3.2 Transition zone between engine room and cargo area

In the transition zone between the engine room and the aftermost cargo hold due consideration is to be given to the proper tapering of major longitudinal members within the engine room such as flats, decks, horizontal rings or side stringers into the cargo hold, and for longitudinal bulkheads (inner skin, upper and lower wing tank) into the engine room.

Where such structure is in line with longitudinal members aft or forward of the cargo hold bulkhead, adequate tapering is to be achieved by fitting large tapering brackets inside the wing tanks or engine room.

##### 1.3.3 Deck discontinuities

Decks which are interrupted in the machinery space are to be tapered on the side by means of horizontal brackets.



## **2 Double bottom**

### **2.1 Arrangement**

#### **2.1.1 General**

Where the machinery space is immediately forward of the after peak, the double bottom is to be transversely framed. In all other cases it may be transversely or longitudinally framed.

#### **2.1.2 Double bottom height**

The double bottom height at the centreline, irrespective of the location of the machinery space, is to be not less than the value defined in Ch 3, Sec 6, [6.1]. This depth may need to be considerably increased in relation to the type and depth of main machinery seatings.

The above height is to be increased by the Shipyard where the machinery space is very large and where there is a considerable variation in draught between light ballast and full load conditions.

Where the double bottom height in the machinery space differs from that in adjacent spaces, structural continuity of longitudinal members is to be ensured by sloping the inner bottom over an adequate longitudinal extent. The knuckles in the sloped inner bottom are to be located in way of floors.

#### **2.1.3 Centre bottom girder**

In general, the centre bottom girder may not be provided with holes. In any case, in way of any openings for manholes on the centre girder, permitted only where absolutely necessary for double bottom access and maintenance, local strengthening is to be arranged.

#### **2.1.4 Side bottom girders**

In the machinery space the number of side bottom girders is to be adequately increased, with respect to the adjacent areas, to ensure adequate rigidity of the structure. The side bottom girders are to be a continuation of any bottom longitudinals in the areas adjacent to the machinery space and are generally to have a spacing not greater than 3 times that of longitudinals and in no case greater than 3 m.

#### **2.1.5 Side bottom girders in way of machinery seatings**

Additional side bottom girders are to be fitted in way of machinery seatings.

Side bottom girders arranged in way of main machinery seatings are to extend for the full length of the machinery space.

Bottom girders are to extend as far aft as practicable in relation to the shape of the bottom and are to be supported by floors and side primary supporting members at the ends.

Forward of the machinery space forward bulkhead, the bottom girders are to be tapered for at least three frame spaces and are to be effectively connected to the hull structure.

#### **2.1.6 Floors in longitudinally framed double bottom**

Where the double bottom is longitudinally framed, the floor spacing is to be not greater than:

- 1 frame spacing in way of the main engine and thrust bearing
- 2 frame spacings in other areas of the machinery space.

Additional floors are to be fitted in way of other important machinery.

#### **2.1.7 Floors in transversely framed double bottom**

Where the double bottom in the machinery space is transversely framed, floors are to be arranged at every frame.

Furthermore, additional floors are to be fitted in way of boiler foundations or other important machinery.

#### **2.1.8 Floors stiffeners**

In addition to the requirements in Ch 3, Sec 6, floors are to have web stiffeners sniped at the ends and spaced not more than approximately 1 m apart.

The section modulus of web stiffeners is to be not less than 1.2 times that required in Ch 6, Sec 2, 4.1.2.

#### **2.1.9 Manholes and wells**

The number and size of manholes in floors located in way of seatings and adjacent areas are to be kept to the

minimum necessary for double bottom access and maintenance.

The depth of manholes is generally to be not greater than 40% of the floor local depth, and in no case greater than 750 mm, and their width is to be equal to approximately 400 mm.

In general, manhole edges are to be stiffened with flanges; failing this, the floor plate is to be adequately stiffened with flat bars at manhole sides.

Manholes with perforated portable plates are to be fitted in the inner bottom in the vicinity of wells arranged close to the aft bulkhead of the engine room.

Drainage of the tunnel is to be arranged through a well located at the aft end of the tunnel.

## 2.2 Minimum thicknesses

### 2.2.1

The net thicknesses of inner bottom, floor and girder webs are to be not less than the values given in Table 1.

<i>Element</i>	<i>Minimum net thickness, in mm</i>
Inner bottom	$6.6 + 0.024L$ The Society may require the thickness of the inner bottom in way of the machinery seatings and on the main thrust blocks to be increased, on a case by case basis.
Margin plate	$0.9L^{1/2} + 1$
Centre girder	$1.55L^{1/3} + 3.5$
Floors and side girders	$1.7L^{1/3} + 1$
Girder bounding a duct keel	$0.8L^{1/2} + 2.5$ , to be taken not less than that required for the centre girder.

## 3 Side

### 3.1 Arrangement

#### 3.1.1 General

The type of side framing in machinery spaces is generally to be the same as that adopted in the adjacent areas.

#### 3.1.2 Extension of the hull longitudinal structure within the machinery space

In ships where the machinery space is located aft and where the side is longitudinally framed, the longitudinal structure is preferably to extend for the full length of the machinery space.

In any event, the longitudinal structure is to be maintained for at least 0.3 times the length of the machinery space, calculated from the forward bulkhead of the latter, and abrupt structural discontinuities between longitudinally and transversely framed structures are to be avoided.

#### 3.1.3 Side transverses

Side transverses are to be aligned with floors. One is preferably to be located in way of the forward end and another in way of the after end of the machinery casing.

For a longitudinally framed side, the side transverse spacing is to be not greater than 4 frame spacings.

For a transversely framed side, the side transverse spacing is to be not greater than 5 frame spaces. The web height is to be not less than twice that of adjacent frames and the section modulus is to be not less than four times that of adjacent frames.

Side transverse spacing greater than that above may be accepted provided that the scantlings of ordinary frames are increased, according to the Society's requirements to be defined on a case by case basis.

## **4 Platforms**

### **4.1 Arrangement**

#### **4.1.1 General**

The location and extension of platforms in machinery spaces are to be arranged so as to be a continuation of the structure of side longitudinals, as well as of platforms and side girders located in the adjacent hull areas.

#### **4.1.2 Platform transverses**

In general, platform transverses are to be arranged in way of side or longitudinal bulkhead transverses.

For longitudinally framed platforms, the spacing of platform transverses is to be not greater than 4 frame spacings.

### **4.2 Minimum thicknesses**

#### **4.2.1**

The net thickness of platforms is to be not less than 6.5 mm.

## **5 Pillaring**

### **5.1 Arrangement**

#### **5.1.1 General**

The pillaring arrangement in machinery spaces is to account both for the concentrated loads transmitted by machinery and superstructures and for the position of main machinery and auxiliary engines.

#### **5.1.2 Pillars**

Pillars are to be arranged in the following positions:

- in way of machinery casing corners and corners of large openings on platforms; alternatively, two pillars may be fitted on the centreline (one at each end of the opening)
- in way of the intersection of platform transverses and girders
- in way of transverse and longitudinal bulkheads of the superstructure.

In general, pillars are to be fitted with brackets at their ends.

#### **5.1.3 Pillar bulkheads**

In general, pillar bulkheads, fitted in 'tween decks below the upper deck, are to be located in way of load-bearing bulkheads in the superstructures.

Longitudinal pillar bulkheads are to be a continuation of main longitudinal hull structures in the adjacent spaces forward and aft of the machinery space.

Pillar bulkhead scantlings are to be not less than those required in [6.3] for machinery casing bulkheads.

## **6 Machinery casing**

### **6.1 Arrangement**

#### **6.1.1 Ordinary stiffener spacing**

Ordinary stiffeners are to be located:

- at each frame, in longitudinal bulkheads
- at a distance of about 750 mm, in transverse bulkheads.

The ordinary stiffener spacing in portions of casings that are particularly exposed to wave action is considered by the Society on a case by case basis.

## **6.2 Openings**

### **6.2.1 General**

All machinery space openings, which are to comply with the requirements in Sec 6, [6], are to be enclosed in a steel casing leading to the highest open deck. Casings are to be reinforced at the ends by deck beams and girders associated to pillars.

In the case of large openings, the arrangement of cross-ties as a continuation of deck beams may be required.

Skylights, where fitted with openings for light and air, are to have coamings of a height not less than:

- 900 mm, if in position 1
- 760 mm, if in position 2.

### **6.2.2 Access doors**

Access doors to casings are to comply with Sec 6, [6.2].

## **6.3 Scantlings**

### **6.3.1 Plating and ordinary stiffeners**

The net scantlings of plating and ordinary stiffeners are to be not less than those obtained according to the applicable requirements in Ch 9, Sec 4.

### **6.3.2 Minimum thicknesses**

The net thickness of bulkheads is to be not less than:

- 5.5 mm for bulkheads in way of cargo holds
- 4 mm for bulkheads in way of accommodation spaces.

## **7 Main machinery seating**

### **7.1 Arrangement**

#### **7.1.1 General**

The scantlings of main machinery seatings and thrust bearings are to be adequate in relation to the weight and power of engines and the static and dynamic forces transmitted by the propulsive installation.

#### **7.1.2 Seating supporting structure**

Transverse and longitudinal members supporting the seatings are to be located in line with floors and double or single bottom girders, respectively.

They are to be so arranged as to avoid discontinuity and ensure sufficient accessibility for welding of joints and for surveys and maintenance.

#### **7.1.3 Seatings included in the double bottom structure**

Where high-power internal combustion engines or turbines are fitted, seatings are to be integral with the double bottom structure. Girders supporting the bedplates in way of seatings are to be aligned with double bottom girders and are to be extended aft in order to form girders for thrust blocks.

The girders in way of seatings are to be continuous from the bedplates to the bottom shell.

#### **7.1.4 Seatings above the double bottom plating**

Where the seatings are situated above the double bottom plating, the girders in way of seatings are to be fitted with flanged brackets, generally located at each frame and extending towards both the centre of the ship and the sides.

The extension of the seatings above the double bottom plating is to be limited as far as practicable while ensuring adequate spaces for the fitting of bedplate bolts. Bolt holes are to be located such that they do not interfere with seating structures.

#### **7.1.5 Seatings in a single bottom structure**

For ships having a single bottom structure within the machinery space, seatings are to be located above the

floors and to be adequately connected to the latter and to the girders located below.

### 7.1.6 Number of girders in way of machinery seatings

At least two girders are to be fitted in way of main machinery seatings.

One girder may be fitted only where the following three formulae are complied with:

$$L < 150 \text{ m}$$

$$P < 7100 \text{ kW}$$

$$P < 2.3 n_r L_E$$

## 7.2 Minimum scantlings

### 7.2.1

The net scantlings of the structural elements in way of the internal combustion engine seatings are to be obtained from the formulae in Table 2. However, the net cross-sectional area of each bedplate of the seatings may be determined by the engine manufacturers, provided the information regarding permissible foundation stiffness considering the engine characteristics and engine room arrangement, etc..

<b>Table 2 Minimum scantlings of the structural elements in way of machinery seatings</b>	
<i>Scantling minimum value</i>	<i>Scantling minimum value</i>
Net cross-sectional area, in cm <sup>2</sup> , of each bedplate of the seatings	$40 + 70 \frac{P}{n_r L_E}$
Bedplate net thickness, in mm	Bedplates supported by two or more girders: $\sqrt{240 + 175 \frac{P}{n_r L_E}}$ Bedplates supported by one girder: $5 + \sqrt{240 + 175 \frac{P}{n_r L_E}}$
Total web net thickness, in mm, of girders fitted in way of machinery seatings	Bedplates supported by two or more girders: $\sqrt{320 + 215 \frac{P}{n_r L_E}}$ Bedplates supported by one girder: $\sqrt{95 + 65 \frac{P}{n_r L_E}}$
Web net thickness, in mm, of floors fitted in way of machinery seatings	$\sqrt{55 + 40 \frac{P}{n_r L_E}}$

## SECTION 4 SUPERSTRUCTURES AND DECKHOUSES

### Symbols

For symbols not defined in this Section, refer to Ch 1, Sec 4.

$L_2$  = Rule length  $L$ , but to be taken not greater than 300 m

$p_D$  = Lateral pressure for decks, in  $\text{kN/m}^2$ , as defined in [3.2.1]

$p_{SI}$  = Lateral pressure for sides of superstructures, in  $\text{kN/m}^2$ , as defined in [3.2.3]

$k$  = Material factor, defined in Ch 3, Sec 1, [2.2]

$s$  = Spacing, in m, of ordinary stiffeners, measured at mid-span along the chord

$\ell$  = Span, in m, of ordinary stiffeners, measured between the supporting members, see Ch 3, Sec 6, [4.2]

$c$  = Coefficient taken equal to:

$c = 0.75$  for beams, girders and transverses which are simply supported on one or both ends

$c = 0.55$  in other cases

$m_a$  = Coefficient taken equal to:

$$m_a = 0.204 \frac{s}{\ell} \left[ 4 - \left( \frac{s}{\ell} \right)^2 \right], \text{ with } \frac{s}{\ell} \leq 1$$

### 1 General

#### 1.1 Definitions

##### 1.1.1 Superstructure

See Ch 1, Sec 4, [3.12.1]

##### 1.1.2 Deckhouse

See Ch 1, Sec 4, [3.15.1]

##### 1.1.3 Long deckhouse

A long deckhouse is a deckhouse the length of which within  $0.4L$  amidships exceeds  $0.2L$ . The strength of a long deckhouse is to be specially considered.

##### 1.1.4 Short deckhouse

A short deckhouse is a deckhouse not covered by the definition given in [1.1.3].

##### 1.1.5 Non-effective superstructure

For the purpose of this section, all superstructures being located beyond  $0.4L$  amidships or having a length of less than  $0.15L$  are considered as non-effective superstructures.

##### 1.1.6 Insulated funnel

Scantlings of insulated funnels are to be determined as for deckhouses.

##### 1.1.7 Effective superstructure

Effective superstructure is a superstructure not covered by the definition given in 1.1.5.

### 1.2 Gross scantlings

#### 1.2.1

With reference to Ch 3, Sec 2, all scantlings and dimensions referred to in [4] and [5] are gross, i.e. they include the margins for corrosion.

## 2 Arrangement

### 2.1 Strengthening at the ends of superstructures

#### 2.1.1

In way of end bulkheads of superstructures located within  $0.4L$  amidships, the thickness of the strength deck in a breadth of  $0.1B$  from the shell, the thickness of the sheerstrake, and the thickness of the superstructure side plating are to be increased by the percentage of strengthening specified in Table 1. The strengthening is to be extended over a region from 4 frame spacings abaft the end bulkhead to 4 frame spacings forward of the end bulkhead.

<i>Type of superstructure</i>	<i>Strength deck and sheerstrake</i>	<i>Side plating of superstructure</i>
Effective	30%	20%
Non-effective	20%	10%

#### 2.1.2

Under strength decks in way of  $0.6L$  amidships, girders are to be fitted in alignment with longitudinal walls, which are to extend at least over three frame spacings beyond the end points of the longitudinal walls. The girders are to overlap with the longitudinal walls by at least two frame spacings.

### 2.2 Attachment of stiffening members

#### 2.2.1 Attachment of deck beams

Transverse deck beams are to be connected to the frames by brackets according to Ch 3, Sec 6.

Deck beams crossing longitudinal walls and girders may be attached to the stiffeners of longitudinal walls and the webs of girders respectively by welding without brackets.

#### 2.2.2 Attachment of deck girders and transverses

End attachments of girders at bulkheads are to be so dimensioned that the bending moments and shear forces can be transferred. Bulkhead stiffeners under girders are to be sufficiently dimensioned to support the girders.

Face plates are to be stiffened by tripping brackets according to Ch 3, Sec 6. At girders of symmetrical section, they are to be arranged alternately on both sides of the web.

#### 2.2.3 End attachment of superstructure frames

Superstructure frames are to be connected to the main frames below, or to the deck. The end attachment may be carried out in accordance with Fig 1.

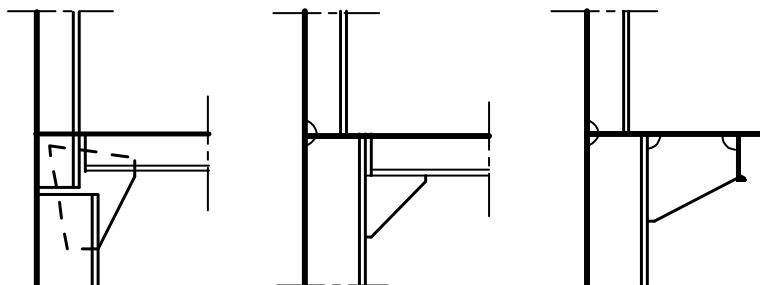

**Fig. 1**  
End attachment of superstructure frames

### 2.3 Transverse structure of superstructures and deckhouses

#### 2.3.1

The transverse structure of superstructures and deckhouses is to be sufficiently dimensioned by a suitable arrangement of end bulkheads, web frames, steel walls of cabins and casings, or by other measures.

## 2.4 Openings in enclosed superstructures

### 2.4.1

Ref. ILLC, as amended (Resolution MSC.143(77) Reg. 12(1))

*All access openings in bulkheads at ends of enclosed superstructures are to be fitted with weathertight doors permanently attached to the bulkhead, and framed, stiffened and fitted so that the whole structure is of equivalent strength to the un-pierced bulkhead. The doors are to be so arranged that they can be operated from both sides of the bulkhead.*

### 2.4.2

Ref. ILLC, as amended (Resolution MSC.143(77) Reg. 12(3))

*The height of the sills of access openings in bulkheads at ends of enclosed superstructures shall be at least 380 mm above the deck.*

### 2.4.3

Any opening in a superstructure deck or in a deckhouse deck directly above the freeboard deck (deckhouse surrounding companionways), is to be protected by efficient weathertight closures.

## 3 Load model

### 3.1 Load calculation point

#### 3.1.1

Unless otherwise specified, lateral pressure is to be calculated at load calculation points defined in:

- Ch 6, Sec 1, [1.5], for plating
- Ch 6, Sec 2, [1.4] for ordinary stiffeners and primary supporting members.

### 3.2 Loads

#### 3.2.1 Lateral pressure for decks

The lateral pressure for decks of superstructures and deckhouses, in kN/m<sup>2</sup>, is to be taken equal to:

- the external pressure  $p_D$  defined in Ch 4, Sec 5, [2.1] for exposed decks,
- 5 kN/m<sup>2</sup> for unexposed decks.

#### 3.2.2 Lateral pressure for exposed wheel house top

The lateral pressure  $p$  for exposed wheel house tops, in kN/m<sup>2</sup>, is to be obtained according to Ch 4, Sec 5, [3.2].

#### 3.2.3 Lateral pressure for sides of superstructures

The lateral pressure  $p_{SI}$  for sides of superstructures, in kN/m<sup>2</sup>, is to be obtained according to Ch 4, Sec 5, [3.3].

## 4 Scantlings

### 4.1 Side plating of non-effective superstructures

#### 4.1.1

The gross thickness, in mm, of the side plating of non-effective superstructures is not to be less than the greater of the following values:

$$t = 1.21s\sqrt{kp_{SI}} + 1.5$$

$$t = 0.8\sqrt{kL}$$



## 4.2 Deck plating of non-effective superstructures

### 4.2.1

The gross thickness, in mm, of deck plating of non-effective superstructures is not to be less than the greater of the following values:

$$t = 1.21s\sqrt{kp_D} + 1.5$$

$$t = (5.5 + 0.02L)\sqrt{k}$$

where  $L$  is not to be taken greater than 200 m.

### 4.2.2

Where additional superstructures are arranged on non-effective superstructures located on the freeboard deck, the gross thickness required by [4.2.1] may be reduced by 10%.

### 4.2.3

Where plated decks are protected by sheathing, the gross thickness of the deck plating according to [4.2.1] and [4.2.2] may be reduced by 1.5mm. However, such deck plating is not to be less than 5 mm.

Where a sheathing other than wood is used, attention is to be paid that the sheathing does not affect the steel. The sheathing is to be effectively fitted to the deck.

## 4.3 Deck beams and supporting deck structure

### 4.3.1 Transverse deck beams and deck longitudinal ordinary stiffeners

The section modulus  $w$ , in  $\text{cm}^3$ , and the shear area  $A_{sh}$ , in  $\text{cm}^2$ , of transverse deck beams and of deck longitudinal ordinary stiffeners are not to be less than the values obtained from the following formulae:

$$w = ckp_D s \ell^2$$

$$A_{sh} = 0.05(1 - 0.817m_a)kp_D s \ell$$

### 4.3.2 Deck girders and transverses

The section modulus  $w$ , in  $\text{cm}^3$ , and the shear area  $A_{sh}$ , in  $\text{cm}^2$ , of deck girders and transverses are not to be less than the values obtained from the following formulae:

$$w = ckp_D e \ell^2$$

$$A_{sh} = 0.05kp_D e \ell$$

where:

$e$  = Width of loaded area, in m, of the unsupported adjacent plate fields, measured from each mid of plate field to mid of opposite plate field.

The girder depth is not to be less than  $\ell/25$ . The web depth of girders scalloped for continuous deck beams is to be at least 1.5 times the depth of the deck beams.

Where a girder does not have the same section modulus throughout all girder fields, the greater scantlings are to be maintained above the supports and are to be reduced gradually to the smaller scantlings.

## 4.4 Superstructure frames

### 4.4.1 Section modulus and shear area

The section modulus  $w$ , in  $\text{cm}^3$ , and the shear area  $A_{sh}$ , in  $\text{cm}^2$ , of the superstructure frames are not to be less than the values obtained from the following formulae:

$$w = 0.55kp_{SI} s \ell^2$$

$$A_{sh} = 0.05(1 - 0.817m_a)kp_{SI} s \ell$$

#### 4.4.2

Where frames are supported by a longitudinally framed deck, the frames fitted between web frames are to be connected to the adjacent longitudinal ordinary stiffeners by brackets. The scantlings of the brackets are to be determined in accordance with Ch 3, Sec 6 on the basis of the section modulus of the frames.

#### 4.4.3

Where further superstructures or deckhouses are arranged on the superstructures, strengthening of the frames of the space below may be required.

### 4.5 Decks of short deckhouses

#### 4.5.1 Plating

The thickness, in mm, of weather deck of short deckhouses and is not to be less than:

$$t = 8s\sqrt{k} + 1.5$$

For weather decks of short deckhouses protected by sheathing and for decks within deckhouses, the gross thickness may be reduced by 1.5mm. However, such deck plating is not to be less than 5 mm.

#### 4.5.2 Deck beams

The scantlings of deck beams and supporting deck structure are to be determined according to [4.3].

## 5 End bulkheads of superstructure and deckhouse

### 5.1 Application

#### 5.1.1

The requirements in 5.2 and 5.3 apply to end bulkhead of superstructure and deckhouse forming the only protection for openings, are required by ILLC as amended, and for accommodation.

### 5.2 Loads

#### 5.2.1

The design load  $p_A$ , in kN/m, for determining the scantlings is to be obtained according to Ch 4, Sec 5, [3.4].

### 5.3 Scantlings

#### 5.3.1 Stiffeners

The section modulus  $w$ , in cm<sup>3</sup> of the stiffeners is not to be less than the value obtained from the following formula:

$$w = 0.35kp_A s \ell^2$$

This requirement assume the webs of lowest tier stiffeners to be efficiently welded to the decks. Scantlings for other types of end connections may be specially considered.

The section modulus of deckhouse side stiffeners needs not to be greater than that of side frames on the deck situated directly below; taking account of spacing  $s$  and span  $\ell$ .

#### 5.3.2 Plate thickness

The gross thickness of the plating, in mm, is not to be less than the greater of the values obtained from the following formulae:

$$t = 0.9s\sqrt{kp_A} + 1.5$$

$$t_{\min} = \left(5.0 + \frac{L_2}{100}\right)\sqrt{k}, \text{ for the lowest tier}$$

$$t_{\min} = \left(4.0 + \frac{L_2}{100}\right)\sqrt{k}, \text{ for the upper tiers, without being less than 5.0 mm.}$$

## SECTION 5 HATCH COVERS

### Symbols

For symbols not defined in this Section, refer to Ch 1, Sec 4.

$p_S$	= Still water pressure, in kN/m <sup>2</sup> , defined in [4.1]
$p_W$	= Wave pressure, in kN/m <sup>2</sup> , defined in [4.1]
$p_C$	= Pressure acting on the hatch coaming, in kN/m <sup>2</sup> , defined in [6.2]
$F_S, F_W$	= Coefficients taken equal to: $F_S = 0$ and $F_W = 0.9$ for ballast water loads on hatch covers of the ballast hold $F_S = 1.0$ and $F_W = 1.0$ in other cases
$s$	= Length, in m, of the shorter side of the elementary plate panel
$\ell$	= Length, in m, of the longer side of the elementary plate panel
$b_p$	= Effective width, in m, of the plating attached to the ordinary stiffener or primary supporting member, defined in [3]
$w$	= Net section modulus, in cm <sup>3</sup> , of the ordinary stiffener or primary supporting member, with an attached plating of width $b_p$
$A_{sh}$	= Net shear sectional area, in cm <sup>2</sup> , of the ordinary stiffener or primary supporting member
$m$	= Boundary coefficient for ordinary stiffeners and primary supporting members, taken equal to: $m = 8$ , in the case of ordinary stiffeners and primary supporting members simply supported at both ends or supported at one end and clamped at the other end $m = 12$ , in the case of ordinary stiffeners and primary supporting members clamped at both ends
$t_C$	= Total corrosion addition, in mm, defined in [1.4]
$\sigma_a, \tau_a$	= Allowable stresses, in N/mm <sup>2</sup> , defined in [1.5].

### 1 General

#### 1.1 Application

##### 1.1.1

The requirements in [1] to [8] apply to steel hatch covers in positions 1 and 2 on weather decks, defined in Ch 1, Sec 4, [3.20].

The requirements in [9] apply to steel hatch covers of small hatches fitted on the exposed fore deck over the forward  $0.25L$ .

#### 1.2 Materials

##### 1.2.1 Steel

The formulae for scantlings given in [5] are applicable to steel hatch covers.

Materials used for the construction of steel hatch covers are to comply with the applicable requirements of the Society.

##### 1.2.2 Other materials

The use of materials other than steel is considered by the Society on a case by case basis, by checking that criteria adopted for scantlings are such as to ensure strength and stiffness equivalent to those of steel hatch covers.

#### 1.3 Net scantlings

##### 1.3.1

All scantlings referred to in this Section, except otherwise specified, are net, i.e. they do not include any margin for corrosion.

When calculating the stresses  $\sigma$  and  $\tau$  in [5.3] and [5.4], the net scantlings are to be used.

The gross scantlings are obtained as specified in Ch 3, Sec 2.

The corrosion additions are given in [1.4].

## 1.4 Corrosion additions

### 1.4.1

The total corrosion addition for both sides to be considered for the plating and internal members of hatch covers is equal to the value specified in Table 1.

The corrosion addition for hatch coamings and coaming stays is defined according to Ch 3, Sec 3.

<b>Table 1 Corrosion addition <math>t_C</math> for hatch covers</b>	
<i>Corrosion addition <math>t_C</math>, in mm, for both sides</i>	
Plating and stiffeners of single skin hatch cover	2.0
Top and bottom plating of double skin hatch cover	2.0
Internal structures of double skin hatch cover	1.5

## 1.5 Allowable stresses

### 1.5.1

Ref. ILLC, as amended (Resolution MSC.143(77) Reg. 15(6) and 16(5))

The allowable stresses  $\sigma_a$  and  $\tau_a$ , in  $N/mm^2$ , are to be obtained from Table 2.

<b>Table 2 Allowable stresses, in <math>N/mm^2</math></b>			
<i>Members of</i>	<i>Subjected to</i>	$\sigma_a$ in $N/mm^2$	$\tau_a$ in $N/mm^2$
Weathertight hatch cover	External pressure, as defined in Ch 4, sec 5, [5.2.1]	0.80 $R_{eH}$	0.46 $R_{eH}$
Pontoon hatch cover		0.68 $R_{eH}$	0.39 $R_{eH}$
Weathertight hatch cover and pontoon hatch cover	Other loads, as defined in Ch 4, Sec 5, [5.1.1] and Ch 4, Sec 6, [2]	0.90 $R_{eH}$	0.51 $R_{eH}$

## **2 Arrangements**

### **2.1 Height of hatch coamings**

#### **2.1.1**

*Ref. ILLC, as amended (Resolution MSC.143(77) Reg. 14 (1, 1))*

The height above the deck of hatch coamings is to be not less than:

- 600 mm in position 1
- 450 mm in position 2.

#### **2.1.2**

*Ref. ILLC, as amended (Resolution MSC.143(77) Reg. 14 (1, 2))*

*The height of hatch coamings in positions 1 and 2 closed by steel covers provided with gaskets and securing devices may be reduced with respect to the above values or the coamings may be omitted entirely, on condition that the Administration is satisfied that the safety of the ship is not thereby impaired in any sea conditions.*

In such cases the scantlings of the covers, their gasketing, their securing arrangements and the drainage of recesses in the deck are considered by the Society on a case by case basis.

#### **2.1.3**

Regardless of the type of closing arrangement adopted, the coamings may have reduced height or be omitted in way of openings in closed superstructures.

### **2.2 Hatch covers**

#### **2.2.1**

Hatch covers on exposed decks are to be weathertight.

Hatch covers in closed superstructures need not be weathertight.

However, hatch covers fitted in way of ballast tanks, fuel oil tanks or other tanks are to be watertight.

#### **2.2.2**

The ordinary stiffeners and primary supporting members of the hatch covers are to be continuous over the breadth and length of the hatch covers, as far as practical. When this is impractical, sniped end connections are not to be used and appropriate arrangements are to be adopted to ensure sufficient load carrying capacity.

#### **2.2.3**

The spacing of primary supporting members parallel to the direction of ordinary stiffeners is to be not greater than 1/3 of the span of primary supporting members.

#### **2.2.4**

The breadth of the primary supporting member face plate is to be not less than 40% of their depth for laterally unsupported spans greater than 3 m. Tripping brackets attached to the face plate may be considered as a lateral support for primary supporting members.

The face plate outstand is not to exceed 15 times the gross face plate thickness.

#### **2.2.5**

Efficient retaining arrangements are to be provided to prevent translation of the hatch cover under the action of the longitudinal and transverse forces exerted by cargoes on the cover, if any. These retaining arrangements are to be located in way of the hatch coaming side brackets.

#### **2.2.6**

The width of each bearing surface for hatch covers is to be at least 65 mm.

### **2.3 Hatch coamings**

#### **2.3.1**

Coamings, stiffeners and brackets are to be capable of withstanding the local forces in way of the clamping devices and handling facilities necessary for securing and moving the hatch covers as well as those due to cargo

stowed on the latter.

### 2.3.2

Special attention is to be paid to the strength of the fore transverse coaming of the forward hatch and to the scantlings of the closing devices of the hatch cover on this coaming.

### 2.3.3

Longitudinal coamings are to be extended at least to the lower edge of deck beams.

- where they are not part of continuous deck girders, the lower edge of longitudinal coamings are to extend for at least two frame spaces beyond the end of the openings.
- where longitudinal coamings are part of deck girders, their scantlings are to be as required in Ch 6, Sec 4.

### 2.3.4

A web frame or a similar structure is to be provided below the deck in line with the transverse coaming. Transverse coamings are to extend below the deck and to be connected with the web frames.

## 2.4 Small hatchways

### 2.4.1

The height of small hatchway coamings is to be not less than 600 mm if located in position 1 and 450 mm if located in position 2.

Where the closing appliances are in the form of hinged steel covers secured weathertight by gaskets and swing bolts, the height of the coamings may be reduced or the coamings may be omitted altogether.

### 2.4.2

Small hatch covers are to have strength equivalent to that required for main hatchways and are to be of steel, weathertight and generally hinged.

Securing arrangements and stiffening of hatch cover edges are to be such that weathertightness can be maintained in any sea condition.

At least one securing device is to be fitted at each side. Circular hole hinges are considered equivalent to securing devices.

### 2.4.3

Hold accesses located on the weather deck are to be provided with weathertight metallic hatch covers, unless they are protected by a closed superstructure. The same applies to accesses located on the forecastle deck and leading directly to a dry cargo hold through a trunk.

### 2.4.4

Accesses to cofferdams and ballast tanks are to be manholes fitted with watertight covers fixed with bolts which are sufficiently closely spaced.

### 2.4.5

Hatchways of special design are considered by the Society on a case by case basis.

## 3 Width of attached plating

### 3.1 Ordinary stiffeners

#### 3.1.1

The width of the attached plating to be considered for the check of ordinary stiffeners is to be obtained, in m, from the following formulae:

- where the attached plating extends on both sides of the stiffener:

$$b_p = s$$

- where the attached plating extends on one side of the stiffener:

$$b_p = 0.5s$$

## 3.2 Primary supporting members

### 3.2.1

The effective width of the attached plating to be considered for the yielding and buckling checks of primary supporting members analysed through isolated beam or grillage model is to be obtained, in m, from the following formulae:

— where the plating extends on both sides of the primary supporting member:

$$b_p = b_{p,1} + b_{p,2}$$

— where the plating extends on one side of the primary supporting member:

$$b_p = b_{p,1}$$

where:

$$b_{p,1} = \min(0.165\ell_p, S_{p,1})$$

$$b_{p,2} = \min(0.165\ell_p, S_{p,2})$$

$\ell_p$  = Span, in m, of the considered primary supporting member  
 $S_{p,1}, S_{p,2}$  = Half distance, in m, between the considered primary supporting member and the adjacent ones,  $S_{p,1}$  for one side,  $S_{p,2}$  for the other side.

When a isolated beam or a grillage analysis is used, the areas of ordinary stiffeners are not to be included in the attached plating of the primary members.

## 4 Load model

### 4.1 Lateral pressures and forces

#### 4.1.1 General

The lateral pressures and forces to be considered as acting on hatch covers are indicated in [4.1.2] to [4.1.6]. When two or more panels are connected by hinges, each individual panel is to be considered separately.

In any case, the sea pressures defined in [4.1.2] are to be considered for hatch covers located on exposed decks. Additionally, when the hatch cover is intended to carry uniform cargoes, special cargoes or containers, the pressures and forces defined in [4.1.3] to [4.1.6] are to be considered independently from the sea pressures.

#### 4.1.2 Sea pressures

The still water and wave lateral pressures are to be considered and are to be taken equal to:

- still water pressure:  $p_S$
- wave pressure  $p_W$ , as defined in Ch 4, Sec 5, [5.2].

#### 4.1.3 Internal pressures due ballast water

If applicable, the static and dynamic lateral pressures are to be considered and are defined in Ch 4, Sec 6, [2].

#### 4.1.4 Pressures due to uniform cargoes

If applicable, the static and dynamic pressures are to be considered and are defined in Ch 4, Sec 5, [2.4.1]

#### 4.1.5 Pressures or forces due to special cargoes

In the case of carriage on the hatch covers of special cargoes (e.g. pipes, etc.) which may temporarily retain water during navigation, the lateral pressures or forces to be applied are considered by the Society on a case by case basis.

#### 4.1.6 Forces due to containers

In the case of carriage of containers on the hatch covers, the concentrated forces under the containers corners are to be determined in accordance with the applicable requirements of the Society.

## 4.2 Load point

### 4.2.1 Wave lateral pressure for hatch covers on exposed decks

The wave lateral pressure to be considered as acting on each hatch cover is to be calculated at a point located:

- longitudinally, at the hatch cover mid-length
- transversely, on the longitudinal plane of symmetry of the ship
- vertically, at the top of the hatch cover.

### 4.2.2 Lateral pressures other than the wave pressure

The lateral pressure is to be calculated:

- in way of the geometrical centre of gravity of the plate panel, for plating
- at mid-span, for ordinary stiffeners and primary supporting members.

## 5 Strength check

### 5.1 General

#### 5.1.1 Application

The strength check is applicable to rectangular hatch covers subjected to a uniform pressure, designed with primary supporting members arranged in one direction or as a grillage of longitudinal and transverse primary supporting members.

In the latter case, the stresses in the primary supporting members are to be determined by a grillage or a finite element analysis.

It is to be checked that stresses induced by concentrated loads are in accordance with the criteria in [5.4.4].

#### 5.1.2 Hatch covers supporting containers

The scantlings of hatch covers supporting containers are to comply with the applicable provisions of the Society.

#### 5.1.3 Hatch covers subjected to special cargoes

For hatch covers supporting special cargoes, ordinary stiffeners and primary supporting members are generally to be checked by direct calculations, taking into account the stiffener arrangements and their relative inertia. It is to be checked that stresses induced by special cargoes are in accordance with the criteria in [5.4.4].

#### 5.1.4 Covers of small hatchways

The gross thickness of covers is to be not less than 8 mm. This thickness is to be increased or an efficient stiffening fitted to the Society's satisfaction where the greatest horizontal dimension of the cover exceeds 0.6 m.

### 5.2 Plating

#### 5.2.1 Net thickness

The net thickness of steel hatch cover top plating, in mm, is to be not less than the value obtained from the following formula:

$$t = 15.8 F_p s \sqrt{\frac{F_S p_S + F_W p_W}{0.95 R_{eH}}}$$

where:

$F_p$  = Factor for combined membrane and bending response, equal to:

$F_p = 1.5$  in general

$F_p = 1.9 \sigma / \sigma_a$ , for  $\sigma \geq 0.8 \sigma_a$  for the attached plating of primary supporting members

$\sigma$  = Normal stress, in  $\text{N/mm}^2$ , in the attached plating of primary supporting members, calculated according to [5.4.3] or determined through a grillage analysis or a finite element analysis, as the case may be.

#### 5.2.2 Minimum net thickness

Ref. ILLC, as amended (Resolution MSC.143(77) Reg. 16 (5, c))



In addition to [5.2.1], the net thickness, in mm, of the plating forming the top of the hatch cover is to be not less than the greater of the following values:

$$t = 10s$$

$$t = 6$$

### 5.2.3 Critical buckling stress check

The compressive stress  $\sigma$  in the hatch cover plating, induced by the bending of primary supporting members, parallel to the direction of ordinary stiffeners is to comply with the following formula:

$$\sigma \leq \frac{0.88}{S} \sigma_{C1}$$

where:

$S$  = Safety factor defined in Ch 6, Sec 3

$\sigma_{C1}$  = Critical buckling stress, in N/mm<sup>2</sup>, taken equal to:

$$\sigma_{C1} = \sigma_{E1} \quad \text{for} \quad \sigma_{E1} \leq \frac{R_{eH}}{2}$$

$$\sigma_{C1} = R_{eH} \left( 1 - \frac{R_{eH}}{4\sigma_{E1}} \right) \quad \text{for} \quad \sigma_{E1} > \frac{R_{eH}}{2}$$

$$\sigma_{E1} = 3.6 E \left( \frac{t}{1000s} \right)^2$$

$t$  = Net thickness, in mm, of plate panel

The compressive stress  $\sigma$  in the hatch cover plating, induced by the bending of primary supporting members, perpendicular to the direction of ordinary stiffeners is to comply with the following formula:

$$\sigma \leq \frac{0.88}{S} \sigma_{C2}$$

where:

$S$  = Safety factor defined in Ch 6, Sec 3

$\sigma_{C2}$  = Critical buckling stress, in N/mm<sup>2</sup>, taken equal to:

$$\sigma_{C2} = \sigma_{E2} \quad \text{for} \quad \sigma_{E2} \leq \frac{R_{eH}}{2}$$

$$\sigma_{C2} = R_{eH} \left( 1 - \frac{R_{eH}}{4\sigma_{E2}} \right) \quad \text{for} \quad \sigma_{E2} > \frac{R_{eH}}{2}$$

$$\sigma_{E2} = 0.9 m E \left( \frac{t}{1000s_s} \right)^2$$

$m$  = Coefficient taken equal to:

$$m = c \left[ 1 + \left( \frac{s_s}{\ell_s} \right)^2 \right]^{\frac{1}{2}} \frac{2.1}{\psi + 1.1}$$

$t$  = Net thickness, in mm, of plate panel

$s_s$  = Length, in m, of the shorter side of the plate panel

$\ell_s$  = Length, in m, of the longer side of the plate panel

$\psi$  = Ratio between smallest and largest compressive stress

$c$  = Coefficient taken equal to:

- $c = 1.3$  when plating is stiffened by primary supporting members
- $c = 1.21$  when plating is stiffened by ordinary stiffeners of angle or T type
- $c = 1.1$  when plating is stiffened by ordinary stiffeners of bulb type
- $c = 1.05$  when plating is stiffened by flat bar.
- $c = 1.30$  when plating is stiffened by ordinary stiffeners of U type. The higher  $c$  value but not greater than 2.0 may be taken if it is verified by buckling strength check of panel using non-linear FEA and deemed appropriate by the Society.

An averaged value of  $c$  is to be used for plate panels having different edge stiffeners.

The bi-axial compression stress in the hatch cover plating, when calculated by means of finite element analysis, is to comply with the requirements in Ch 6, Sec 3.

### 5.3 Ordinary stiffeners

#### 5.3.1

For flat bar ordinary stiffeners, the ratio  $h_w/t_w$  is to comply with the following formula:

$$\frac{h_w}{t_w} \leq 15 \sqrt{\frac{235}{R_{eH}}}$$

#### 5.3.2 Minimum net thickness of web

The web net thickness of the ordinary stiffener, in mm, is to be not less than 4mm.

#### 5.3.3 Net section modulus and net shear sectional area

The net section modulus  $w$ , in  $\text{cm}^3$ , and the net shear sectional area  $A_{sh}$ , in  $\text{cm}^2$ , of an ordinary stiffener subject to lateral pressure are to be not less than the values obtained from the following formulae:

$$w = \frac{(F_S p_S + F_W p_W) s \ell_s^2}{m \sigma_a} 10^3$$

$$A_{sh} = \frac{5(F_S p_S + F_W p_W) s \ell_s}{\tau_a}$$

where:

$\ell_s$  = Ordinary stiffener span, in m, to be taken as the spacing, in m, of primary supporting members or the distance between a primary supporting member and the edge support, as applicable. When brackets are fitted at both ends of all ordinary stiffener spans, the ordinary stiffener span may be reduced by an amount equal to 2/3 of the minimum brackets arm length, but not greater than 10% of the gross span, for each bracket.

#### 5.3.4 Critical buckling stress check

The compressive stress  $\sigma$  in the face plate of ordinary stiffeners, induced by the bending of primary supporting members, parallel to the direction of ordinary stiffeners is to comply with the following formula:

$$\sigma \leq \frac{0.88 \sigma_{CS}}{S}$$

where:

$S$  = Safety factor defined in Ch 6, Sec 3

$\sigma_{CS}$  = Critical buckling stress, in  $\text{N/mm}^2$ , taken equal to:

$$\sigma_{CS} = \sigma_{ES} \quad \text{for} \quad \sigma_{ES} \leq \frac{R_{eH}}{2}$$

$$\sigma_{CS} = R_{eH} \left( 1 - \frac{R_{eH}}{4\sigma_{ES}} \right) \quad \text{for} \quad \sigma_{ES} > \frac{R_{eH}}{2}$$

$$\sigma_{ES} = \min(\sigma_{E3}, \sigma_{E4})$$

$$\sigma_{E3} = 0.001 \frac{EI_a}{A\ell^2}$$

$I_a$  = Moment of inertia, in  $\text{cm}^4$ , of the ordinary stiffener, including a face plate equal to spacing of ordinary stiffeners

$A$  = Cross-sectional area, in  $\text{cm}^2$ , of the ordinary stiffener, including a face plate equal to spacing of ordinary stiffeners

$\ell$  = Span, in m, of the ordinary stiffener

$$\sigma_{E4} = \frac{\pi^2 E I_w}{10^4 I_p \ell^2} \left( m^2 + \frac{K}{m^2} \right) + 0.385 E \frac{I_t}{I_p}$$

$$K = \frac{C \ell^4}{\pi^4 E I_w} 10^6$$

$m$  = Number of half waves, given in Table 3.

Table 3 Number of half waves				
	$0 < K < 4$	$4 < K < 36$	$36 < K < 144$	$(m-1)^2 m^2 < K \leq m^2 (m+1)^2$
$m$	1	2	3	$m$

$I_w$  = Sectorial moment of inertia, in  $\text{cm}^6$ , of the ordinary stiffener about its connection with the plating, taken equal to:

$$I_w = \frac{h_w^3 t_w^3}{36} 10^{-6}$$

for flat bar ordinary stiffeners

$$I_w = \frac{t_f b_f^3 h_w^2}{12} 10^{-6}$$

for "Tee" ordinary stiffeners

$$I_w = \frac{b_f^3 h_w^2}{12(b_f + h_w)^2} \left[ t_f (b_f^2 + 2b_f h_w + 4h_w^2) + 3t_w b_f h_w \right] 10^{-6}$$

for angles and bulb ordinary stiffeners

$I_p$  = Polar moment of inertia, in  $\text{cm}^4$ , of the ordinary stiffener about its connection with the plating, taken equal to:

$$I_t = \frac{h_w^3 t_w}{3} 10^{-4}$$

for flat bar ordinary stiffeners

$$I_p = \left( \frac{h_w^3 t_w}{3} + h_w^2 b_f t_f \right) 10^{-4}$$

for flanged ordinary stiffeners

$I_t$  = St Venant's moment of inertia, in  $\text{cm}^4$ , of the ordinary stiffener without face plate, taken equal to:

$$I_t = \frac{h_w^3 t_w}{3} 10^{-4}$$

for flat bar ordinary stiffeners

$$I_t = \frac{1}{3} \left[ h_w t_w^3 + b_f t_f^3 \left( 1 - 0.63 \frac{t_f}{b_f} \right) \right] 10^{-4}$$

for flanged ordinary stiffeners

$C$  = Spring stiffness exerted by the hatch cover top plating, taken equal to:

$$C = \frac{k_p E t_p^3}{3s \left( 1 + \frac{1.33 k_p h_w t_p^3}{1000 s t_w^3} \right)} 10^{-3}$$

$k_p = 1 - \eta_p$  to be taken not less than zero; for flanged ordinary stiffeners,  $k_p$  need not be taken less than 0.1

$$\eta_p = \frac{\sigma}{\sigma_{E1}}$$

$\sigma_{E1}$  = As defined in [5.2.3]

$t_p$  = Net thickness, in mm, of the hatch cover plate panel.

## 5.4 Primary supporting members

### 5.4.1 Application

The requirements in [5.4.3] to [5.4.5] apply to primary supporting members which may be analysed through isolated beam models.

Primary supporting members whose arrangement is of a grillage type and which cannot be analysed through isolated beam models are to be checked by direct calculations, using the checking criteria in [5.4.4].

### 5.4.2 Minimum net thickness of web

The web net thickness of primary supporting members, in mm, is to be not less than 6mm.

### 5.4.3 Normal and shear stress for isolated beam

In case that grillage analysis or finite element analysis are not carried out, according to the requirements in [5.1.1], the maximum normal stress  $\sigma$  and shear stress  $\tau$  in the primary supporting members are to be obtained, in N/mm<sup>2</sup>, from the following formulae:

$$\sigma = \frac{s(F_S p_S + F_W p_W) \ell_m^2}{mW} 10^3$$

$$\tau = \frac{5s(F_S p_S + F_W p_W) \ell_m}{A_{sh}}$$

where:

$\ell_m$  = Span of the primary supporting member.

### 5.4.4 Checking criteria

The normal stress  $\sigma$  and the shear stress  $\tau$ , calculated according to [5.4.3] or determined through a grillage analysis or finite element analysis, as the case may be, are to comply with the following formulae:

$$\sigma \leq \sigma_a$$

$$\tau \leq \tau_a$$

### 5.4.5 Deflection limit

Ref. ILLC, as amended (Resolution MSC.143(77) Reg. 15 (6) and 16 (5, b))

*The net moment of inertia of a primary supporting member, when loaded by sea pressure, is to be such that the deflection does not exceed  $\mu \ell_{\max}$ , where:*

$\mu$  = Coefficient taken equal to:  
 $\mu = 0.0056$  for weathertight hatch covers  
 $\mu = 0.0044$  for pontoon hatch covers  
 $l_{\max}$  = Greatest span, in m, of primary supporting members.

#### 5.4.6 Critical buckling stress check of the web panels of the primary supporting members.

The shear stress  $\tau$  in the web panels of the primary supporting members, calculated according to [5.4.3] or determined through a grillage analysis or a finite element analysis, as the case may be, is to comply with the following formula:

$$\tau \leq \frac{0.88\tau_C}{S}$$

where:

$S$  = Safety factor defined in Ch 6, Sec 3

$\tau_C$  = Critical shear buckling stress, in N/mm<sup>2</sup>, taken equal to:

$$\tau_C = \tau_E \quad \text{for } \tau_E \leq \frac{R_{eH}}{2\sqrt{3}}$$

$$\tau_C = \frac{R_{eH}}{\sqrt{3}} \left( 1 - \frac{R_{eH}}{4\sqrt{3}\tau_E} \right) \quad \text{for } \tau_E > \frac{R_{eH}}{2\sqrt{3}}$$

$$\tau_E = 0.9k_t E \left( \frac{t_{pr,n}}{1000d} \right)^2$$

$$k_t = 5.35 + 4.0 \left( \frac{a}{d} \right)^2$$

$t_{pr,n}$  = Net thickness, in mm, of web of primary supporting member  
 $a$  = Greater dimension, in m, of web panel of primary supporting member  
 $d$  = Smaller dimension, in m, of web panel of primary supporting member.

For primary supporting members parallel to the direction of ordinary stiffeners,  $\tau_C$  is to be calculated by considering the actual dimensions of the panels.

For primary supporting members perpendicular to the direction of ordinary stiffeners or for hatch covers built without ordinary stiffeners, a presumed square panel of dimension  $d$  is to be taken for the determination of the stress  $\tau_C$ , where  $d$  is the smaller dimension, in m, of web panel of the primary supporting member. In such a case, the average shear stress  $\tau$  between the values calculated at the ends of this panel is to be considered.

#### 5.4.7

For buckling stiffeners on webs of primary supporting members, the ratio  $h_w/t_w$  is to comply with the following formula:

$$\frac{h_w}{t_w} \leq 15 \sqrt{\frac{235}{R_{eH}}}$$

### 5.5 Ordinary stiffeners and primary supporting members of variable cross-section

#### 5.5.1

The net section modulus of ordinary stiffeners and primary supporting members with a variable cross-section is to be not less than the greater of the value obtained, in cm<sup>3</sup>, from the following formulae:

$$w = w_{CS}$$

$$w = \left( 1 + \frac{3.2\alpha - \psi - 0.8}{7\psi + 0.4} \right) w_{CS}$$

where:

$w_{CS}$  = Net section modulus, in  $\text{cm}^3$ , for a constant cross-section, complying with the checking criteria in [5.4.4]

$\alpha$  = Coefficient taken equal to:

$$\alpha = \frac{\ell_1}{\ell_0}$$

$\psi$  = Coefficient taken equal to:

$$\psi = \frac{w_1}{w_0}$$

$\ell_1$  = Length of the variable section part, in m (see Fig 1)

$\ell_0$  = Span measured, in m, between end supports (see Fig 1)

$w_1$  = Net section modulus at end, in  $\text{cm}^3$  (see Fig 1)

$w_0$  = Net section modulus at mid-span, in  $\text{cm}^3$  (see Fig 1).

Moreover, the net moment of inertia of ordinary stiffeners and primary supporting members with a variable cross-section is to be not less than the greater of the values obtained, in  $\text{cm}^4$ , from the following formulae:

$$I = I_{CS}$$

$$I = \left[ 1 + 8\alpha^3 \left( \frac{1 - \varphi}{0.2 + 3\sqrt{\varphi}} \right) \right] I_{CS}$$

where:

$I_{CS}$  = Net moment of inertia with a constant cross-section, in  $\text{cm}^4$ , complying with [5.4.5]

$\varphi$  = Coefficient taken equal to:

$$\varphi = \frac{I_1}{I_0}$$

$I_1$  = Net moment of inertia at end, in  $\text{cm}^4$  (see Fig 1)

$I_0$  = Net moment of inertia at mid-span, in  $\text{cm}^4$  (see Fig 1).

The use of these formulae is limited to the determination of the strength of ordinary stiffeners and primary supporting members in which abrupt changes in the cross-section do not occur along their length.

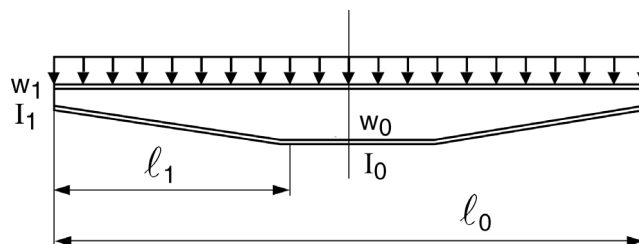

**Fig. 1**  
Variable cross-section stiffener

## 6 Hatch coamings

### 6.1 Stiffening

#### 6.1.1

The ordinary stiffeners of the hatch coamings are to be continuous over the breadth and length of the hatch coamings.

### 6.1.2

Coamings are to be stiffened on their upper edges with a stiffener suitably shaped to fit the hatch cover closing appliances.

Moreover, when covers are fitted with tarpaulins, an angle or a bulb section is to be fitted all around coamings of more than 3 m in length or 600 mm in height; this stiffener is to be fitted at approximately 250 mm below the upper edge. The width of the horizontal flange of the angle is not to be less than 180 mm.

### 6.1.3

Where hatch covers are fitted with tarpaulins, coamings are to be strengthened by brackets or stays with a spacing not greater than 3 m.

Where the height of the coaming exceeds 900 mm, additional strengthening may be required.

However, reductions may be granted for transverse coamings in protected areas.

### 6.1.4

When two hatches are close to each other, underdeck stiffeners are to be fitted to connect the longitudinal coamings with a view to maintaining the continuity of their strength.

Similar stiffening is to be provided over 2 frame spacings at ends of hatches exceeding 9 frame spacings in length.

In some cases, the Society may require the continuity of coamings to be maintained above the deck.

### 6.1.5

Where watertight metallic hatch covers are fitted, other arrangements of equivalent strength may be adopted.

## 6.2 Load model

### 6.2.1

The lateral pressure  $p_C$  to be considered as acting on the hatch coamings is defined in [6.2.2] and [6.2.3].

### 6.2.2

The wave lateral pressure  $p_C$ , in kN/m<sup>2</sup>, on the No 1 forward transverse hatch coaming is to be taken equal to:

$$p_C = 220, \text{ when a forecastle is fitted in accordance with Sec 1, [7.1]}$$

$$p_C = 290, \text{ in the other cases.}$$

### 6.2.3

The wave lateral pressure  $p_C$ , in kN/m<sup>2</sup>, on the hatch coamings other than the No 1 forward transverse hatch coaming is to be taken equal to:

$$p_C = 220$$

### 6.2.4

For cargo holds intended for the carriage of liquid cargoes, the liquid internal pressures applied on hatch coaming is also to be determined according to Ch 4, Sec 6.

## 6.3 Scantlings

### 6.3.1 Plating

The net thickness of the hatch coaming plate is to be not less than the greater value obtained, in mm, from the following formulae:

$$t = 15.98s \sqrt{\frac{p_C}{0.95R_{eH}}}$$

$$t = 9.5$$

### 6.3.2 Ordinary stiffeners

The net section modulus of the longitudinal or transverse ordinary stiffeners of hatch coamings is to be not less

than the value obtained, in  $\text{cm}^3$ , from the following formula:

$$w = 1.21 \frac{p_c s \ell^2 10^3}{m c_p R_{eH}}$$

where:

$m$  = Coefficient taken equal to:

$m = 16$  in general

$m = 12$  for the end span of stiffeners sniped at the coaming corners

$c_p$  = Ratio of the plastic section modulus to the elastic section modulus of the ordinary stiffeners with an attached plate breadth, in mm, equal to  $40t$ , where  $t$  is the plate net thickness.

$c_p = 1.16$  in the absence of more precise evaluation.

### 6.3.3 Coaming stays

The net section modulus  $w$ , in  $\text{cm}^3$ , and the net thickness  $t_w$ , in mm, of the coaming stays designed as beams with flange connected to the deck or sniped and fitted with a bracket (examples shown in Fig 2 and Fig 3) are to be not less than the values obtained from the following formulae at the connection with deck:

$$w = \frac{s_C p_C H_C^2 10^3}{1.9 R_{eH}}$$

$$t_w = \frac{s_C p_C H_C 10^3}{0.5 h R_{eH}}$$

where:

$H_C$  = Stay height, in m

$s_C$  = Stay spacing, in m

$h$  = Stay depth, in mm, at the connection with deck.

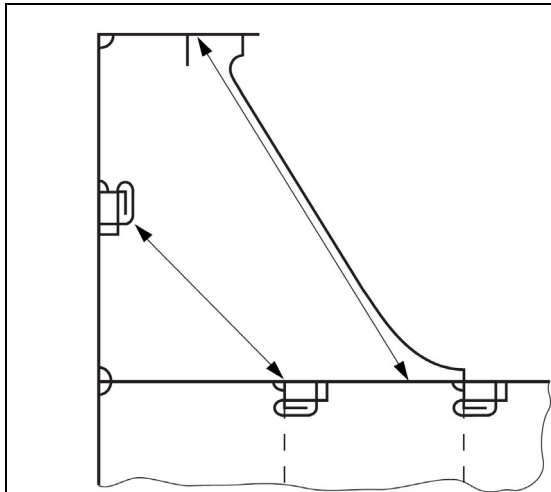

Fig. 2  
Coaming stay: example 1

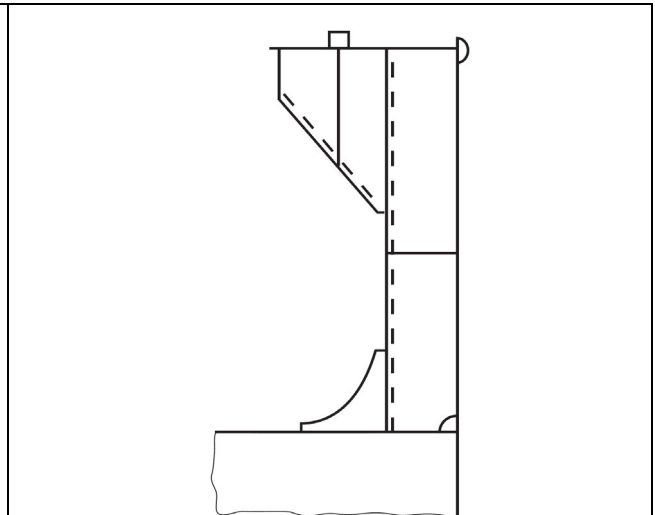

Fig. 3  
Coaming stay: example 2

For calculating the section modulus of coaming stays, their face plate area may be taken into account only when it is welded with full penetration welds to the deck plating and adequate underdeck structure is fitted to support the stresses transmitted by it.

For other designs of coaming stays, such as, for example, those shown in Fig 4 and Fig 5, the stress levels determined through a grillage analysis or finite element analysis, as the case may be, apply and are to be checked at the highest stressed locations. The stress levels are to comply with the following formulae:

$$\sigma \leq 0.95 R_{eH}$$

$$\tau \leq 0.5 R_{eH}$$



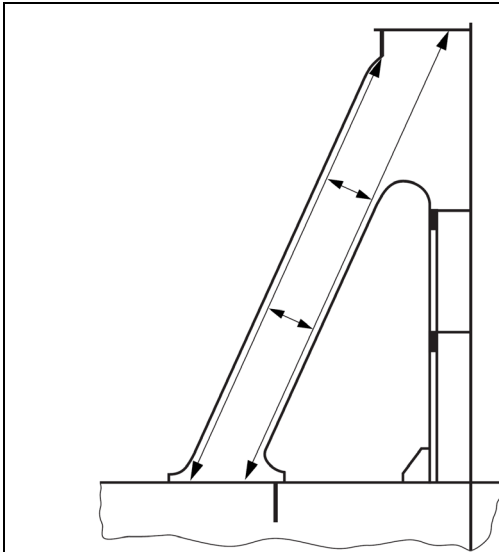

**Fig. 4**  
Coaming stay: example 3

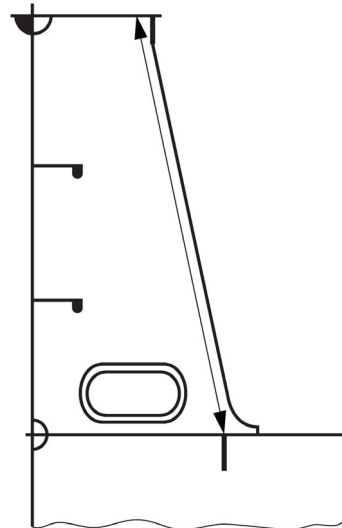

**Fig. 5**  
Coaming stay: example 4

### 6.3.4 Local details

The design of local details is to comply with the requirements in this section for the purpose of transferring the pressures on the hatch covers to the hatch coamings and, through them, to the deck structures below.

Hatch coamings and supporting structures are to be adequately stiffened to accommodate the loading from hatch covers, in longitudinal, transverse and vertical directions.

The normal stress  $\sigma$  and the shear stress  $\tau$ , in  $\text{N/mm}^2$ , induced in the underdeck structures by the loads transmitted by stays are to comply with the following formulae:

$$\sigma \leq 0.95R_{eH}$$

$$\tau \leq 0.5R_{eH}$$

Unless otherwise stated, weld connections and materials are to be dimensioned and selected in accordance with the Society's requirements.

Double continuous fillet welding is to be adopted for the connections of stay webs with deck plating and the weld throat thickness is to be not less than  $0.44t_w$ , where  $t_w$  is the gross thickness of the stay web.

Toes of stay webs are to be connected to the deck plating with deep penetration double bevel welds extending over a distance not less than 15% of the stay width.

### 6.3.5 Coamings of small hatchways

The gross thickness of coaming plate is to be not less than the lesser of the following values:

- the gross thickness for the deck inside line of openings calculated for that position, assuming as spacing of stiffeners the lesser of the values of the height of the coaming and the distance between its stiffeners, if any,  
or
- 10 mm.

Coamings are to be suitably strengthened where their height exceeds 0.8 m or their greatest horizontal dimension exceeds 1.2 m, unless their shape ensures an adequate rigidity.

## 7 Weathertightness, closing arrangement, securing devices and stoppers

### 7.1 Weathertightness

#### 7.1.1

Ref. ILLC, as amended (Resolution MSC.143(77) Reg. 16 (1))

Where the hatchway is exposed, the weathertightness is to be ensured by gaskets and clamping devices sufficient in number and quality.

Weathertightness may also be ensured means of tarpaulins.

### **7.1.2**

In general, a minimum of two securing devices or equivalent is to be provided on each side of the hatch cover.

## **7.2 Gaskets**

### **7.2.1**

The weight of hatch covers and any cargo stowed thereon, together with inertia forces generated by ship motions, are to be transmitted to the ship's structure through steel to steel contact.

This may be achieved by continuous steel to steel contact of the hatch cover skirt plate with the ship's structure or by means of defined bearing pads.

### **7.2.2**

The sealing is to be obtained by a continuous gasket of relatively soft elastic material compressed to achieve the necessary weathertightness. Similar sealing is to be arranged between cross-joint elements.

Where fitted, compression flat bars or angles are to be well rounded where in contact with the gasket and to be made of a corrosion-resistant material.

### **7.2.3**

The gasket and the securing arrangements are to maintain their efficiency when subjected to large relative movements between the hatch cover and the ship's structure or between hatch cover elements.

If necessary, suitable devices are to be fitted to limit such movements.

### **7.2.4**

The gasket material is to be of a quality suitable for all environmental conditions likely to be encountered by the ship, and is to be compatible with the cargoes transported.

The material and form of gasket selected are to be considered in conjunction with the type of hatch cover, the securing arrangement and the expected relative movement between the hatch cover and the ship's structure.

The gasket is to be effectively secured to the hatch cover.

### **7.2.5**

Coamings and steel parts of hatch covers in contact with gaskets are to have no sharp edges.

### **7.2.6**

Metallic contact is required for an earthing connection between the hatch cover and the hull structures. If necessary, this is to be achieved by means of a special connection for the purpose.

## **7.3 Closing arrangement, securing devices and stoppers**

### **7.3.1 General**

Panel hatch covers are to be secured by appropriate devices (bolts, wedges or similar) suitably spaced alongside the coamings and between cover elements.

The securing and stop arrangements are to be fitted using appropriate means which cannot be easily removed.

In addition to the requirements above, all hatch covers, and in particular those carrying deck cargo, are to be effectively secured against horizontal shifting due to the horizontal forces resulting from ship motions.

Towards the ends of the ship, vertical acceleration forces may exceed the gravity force. The resulting lifting forces are to be considered when dimensioning the securing devices according to [7.3.5] to [7.3.7]. Lifting forces from cargo secured on the hatch cover during rolling are also to be taken into account.

Hatch coamings and supporting structure are to be adequately stiffened to accommodate the loading from hatch covers.

Hatch covers provided with special sealing devices, insulated hatch covers, flush hatch covers and those having coamings of a reduced height (see [2.1]) are considered by the Society on a case by case basis.

In the case of hatch covers carrying containers, the scantlings of the closing devices are to take into account the

possible upward vertical forces transmitted by the containers.

### 7.3.2 Arrangements

The securing and stopping devices are to be arranged so as to ensure sufficient compression on gaskets between hatch covers and coamings and between adjacent hatch covers.

Arrangement and spacing are to be determined with due attention to the effectiveness for weathertightness, depending on the type and the size of the hatch cover, as well as on the stiffness of the hatch cover edges between the securing devices.

At cross-joints of multipanel covers, (male/female) vertical guides are to be fitted to prevent excessive relative vertical deflections between loaded/unloaded panels.

The location of stoppers is to be compatible with the relative movements between hatch covers and the ship's structure in order to prevent damage to them. The number of stoppers is to be as small as possible.

### 7.3.3 Spacing

The spacing of the securing arrangements is to be generally not greater than 6 m.

### 7.3.4 Construction

Securing arrangements with reduced scantlings may be accepted provided it can be demonstrated that the possibility of water reaching the deck is negligible.

Securing devices are to be of reliable construction and securely attached to the hatchway coamings, decks or hatch covers.

Individual securing devices on each hatch cover are to have approximately the same stiffness characteristics.

### 7.3.5 Area of securing devices

The net cross area of each securing device is to be not less than the value obtained, in cm<sup>2</sup>, from the following formula:

$$A = 1.4S_S \left( \frac{235}{R_{eH}} \right)^\alpha$$

where:

$S_S$  = Spacing, in m, of securing devices

$\alpha$  = Coefficient taken equal to:

$$\alpha = 0.75 \text{ for } R_{eH} > 235 \text{ N/mm}^2$$

$$\alpha = 1.0 \text{ for } R_{eH} \leq 235 \text{ N/mm}^2$$

In the above calculations,  $R_{eH}$  may not be taken greater than  $0.7R_m$ .

Between hatch cover and coaming and at cross-joints, a packing line pressure sufficient to obtain weathertightness is to be maintained by securing devices. For packing line pressures exceeding 5 N/mm, the net cross area  $A$  is to be increased in direct proportion. The packing line pressure is to be specified.

In the case of securing arrangements which are particularly stressed due to the unusual width of the hatchway, the net cross area  $A$  of the above securing arrangements is to be determined through direct calculations.

### 7.3.6 Inertia of edges elements

The hatch cover edge stiffness is to be sufficient to maintain adequate sealing pressure between securing devices.

The moment of inertia of edge elements is to be not less than the value obtained, in cm<sup>4</sup>, from the following formula:

$$I = 6p_L S_S^4$$

where:

$p_L$  = Packing line pressure, in N/mm, to be taken not less than 5

$S_S$  = Spacing, in m, of securing devices.

### 7.3.7 Diameter of rods or bolts

Rods or bolts are to have a gross diameter not less than 19 mm for hatchways exceeding 5 m<sup>2</sup> in area.

### 7.3.8 Stoppers

Hatch covers are to be effectively secured, by means of stoppers, against the transverse forces arising from a pressure of 175 kN/m<sup>2</sup>.

With the exclusion of No 1 hatch cover, hatch covers are to be effectively secured, by means of stoppers, against the longitudinal forces acting on the forward end arising from a pressure of 175 kN/m<sup>2</sup>.

No 1 hatch cover is to be effectively secured, by means of stoppers, against the longitudinal forces acting on the forward end arising from a pressure of 230 kN/m<sup>2</sup>. This pressure may be reduced to 175 kN/m<sup>2</sup> if a forecabin is fitted in accordance with Sec 1, [7.1].

The equivalent stress in stoppers, their supporting structures and calculated in the throat of the stopper welds is to be equal to or less than the allowable value, equal to  $0.8R_{eH}$ .

## 7.4 Tarpaulins

### 7.4.1

Ref. ILLC, as amended (Resolution MSC.143(77) Reg. 15 (11))

Where weathertightness of hatch covers is ensured by means of tarpaulins, at least two layers of tarpaulins are to be fitted.

Tarpaulins are to be free from jute and waterproof and are to have adequate characteristics of strength and resistance to atmospheric agents and high and low temperatures.

The mass per unit surface of tarpaulins made of vegetable fibres, before the waterproofing treatment, is to be not less than:

- 0.65 kg/m<sup>2</sup> for waterproofing by tarring
- 0.60 kg/m<sup>2</sup> for waterproofing by chemical dressing
- 0.55 kg/m<sup>2</sup> for waterproofing by dressing with black oil.

In addition to tarpaulins made of vegetable fibres, those of synthetic fabrics or plastic laminates may be accepted by the Society provided their qualities, as regards strength, waterproofing and resistance to high and low temperatures, are equivalent to those of tarpaulins made of vegetable fibres.

## 7.5 Cleats

### 7.5.1

Where rod cleats are fitted, resilient washers or cushions are to be incorporated.

### 7.5.2

Where hydraulic cleating is adopted, a positive means is to be provided to ensure that it remains mechanically locked in the closed position in the event of failure of the hydraulic system.

## 7.6 Wedges

### 7.6.1 Wedges

Ref. ILLC, as amended (Resolution MSC.143(77) Reg. 15 (10))

*Wedges are to be of tough wood, generally not more than 200 mm in length and 50 mm in width.*

*They are generally to be tapered not more than 1 in 6 and their thickness is to be not less than 13 mm.*

## 8 Drainage

### 8.1 Arrangement

#### 8.1.1

Drainage is to be arranged inside the line of gaskets by means of a gutter bar or vertical extension of the hatch side and end coaming.

### 8.1.2

Drain openings are to be arranged at the ends of drain channels and are to be provided with efficient means for preventing ingress of water from outside, such as non-return valves or equivalent.

### 8.1.3

Cross-joints of multi-panel hatch covers are to be arranged with drainage of water from the space above the gasket and a drainage channel below the gasket.

### 8.1.4

If a continuous outer steel contact is arranged between the cover and the ship's structure, drainage from the space between the steel contact and the gasket is also to be provided.

## 9 Small hatches fitted on the exposed fore deck

### 9.1 Application

#### 9.1.1

The requirements of this article apply to steel covers of small hatches fitted on the exposed fore deck over the forward 0.25L, where the height of the exposed deck in way of the hatch is less than 0.1L or 22 m above the summer load waterline, whichever is the lesser.

Small hatches are hatches designed for access to spaces below the deck and are capable to be closed weather-tight or watertight, as applicable. Their opening is generally equal to or less than 2.5 m<sup>2</sup>.

#### 9.1.2

Small hatches designed for use of emergency escape are to comply with the requirements of this article with exception of [9.4.1] a) and b), [9.4.3] and [9.5.1].

### 9.2 Strength

#### 9.2.1

For small rectangular steel hatch covers, the gross plate thickness, stiffener arrangement and scantlings are to be not less than those obtained, in mm, from Table 4 and Fig 6.

Ordinary stiffeners, where fitted, are to be aligned with the metal-to-metal contact points, required in [9.3.1] (see also Fig 6).

Primary stiffeners are to be continuous.

All stiffeners are to be welded to the inner edge stiffener (see Fig 7).

Nominal size (mm × mm)	Cover plate thickness (mm)	Primary stiffeners	Ordinary stiffeners
		Flat bar (mm × mm); number	
630 × 630	8	–	–
630 × 830	8	100 × 8 ; 1	–
830 × 630	8	100 × 8 ; 1	–
830 × 830	8	100 × 10 ; 1	–
1030 × 1030	8	120 × 12 ; 1	80 × 8 ; 2
1330 × 1330	8	150 × 12 ; 2	100 × 10 ; 2

#### 9.2.2

The upper edge of the hatchway coamings is to be suitably reinforced by a horizontal section, generally not more than 170 to 190 mm from the upper edge of the coamings.

#### 9.2.3

For small hatch covers of circular or similar shape, the cover plate thickness and reinforcement are to comply with [5.2].

#### **9.2.4**

For small hatch covers constructed of materials other than steel, the required scantlings are to provide equivalent strength.

### **9.3 Weathertightness**

#### **9.3.1**

The hatch cover is to be fitted with a gasket of elastic material. This is to be designed to allow a metal to metal contact at a designed compression and to prevent over compression of the gasket by green sea forces that may cause the securing devices to be loosened or dislodged. The metal-to-metal contacts are to be arranged close to each securing device in accordance with Fig 6 and a sufficient capacity to withstand the bearing force.

### **9.4 Primary securing devices**

#### **9.4.1**

Small hatches located on exposed fore deck are to be fitted with primary securing devices such their hatch covers can be secured in place and weather-tight by means of a mechanism employing any one of the following methods:

- a) butterfly nuts tightening onto forks (clamps)
- b) quick acting cleats
- c) central locking device.

Dogs (twist tightening handles) with wedges are not acceptable.

#### **9.4.2**

The primary securing method is to be designed and manufactured such that the designed compression pressure is achieved by one person without the need of any tools.

#### **9.4.3**

For a primary securing method using butterfly nuts, the forks (clamps) are to be of robust design. They are to be designed to minimize the risk of butterfly nuts being dislodged while in use; by means of curving the forks upward, a raised surface on the free end, or a similar method. The plate thickness of unstiffened steel forks is to be not less than 16 mm. An example arrangement is shown in Fig 7.

#### **9.4.4**

For small hatch covers located on the exposed deck forward of the fore-most cargo hatch, the hinges are to be fitted such that the predominant direction of green seas will cause the cover to close, which means that the hinges are normally to be located on the fore edge.

#### **9.4.5**

On small hatches located between the main hatches, for example between Nos. 1 and 2, the hinges are to be placed on the fore edge or outboard edge, whichever is practicable for protection from green water in beam sea and bow quartering conditions.

### **9.5 Secondary securing devices**

#### **9.5.1**

Small hatches on the fore deck are to be fitted with an independent secondary securing device e.g. by means of a sliding bolt, a hasp or a backing bar of slack fit, which is capable of keeping the hatch cover in place, even in the event that the primary securing device became loosened or dislodged. It is to be fitted on the side opposite to the hatch cover hinges.

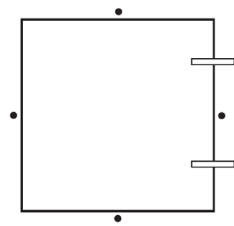

Nominal size 630 x 630

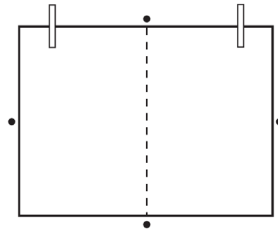

Nominal size 630 x 830

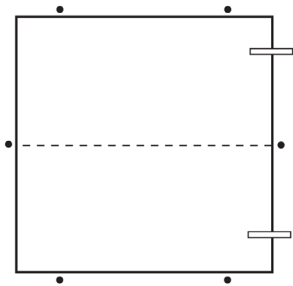

Nominal size 830 x 830

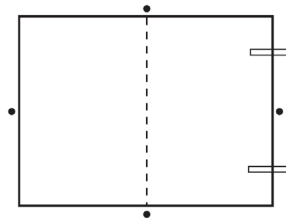

Nominal size 830 x 630

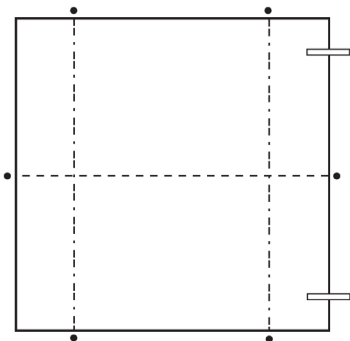

Nominal size 1030 x 1030

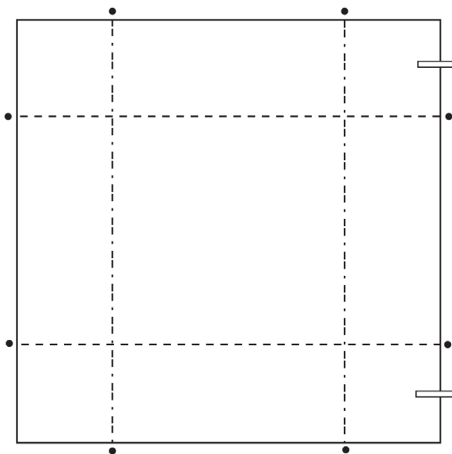

Nominal size 1330 x 1330

— Hinge

• Securing device / metal to metal contact

----- Primary supporting member

----- Ordinary stiffener

**Fig. 6**  
**Arrangement of stiffeners**

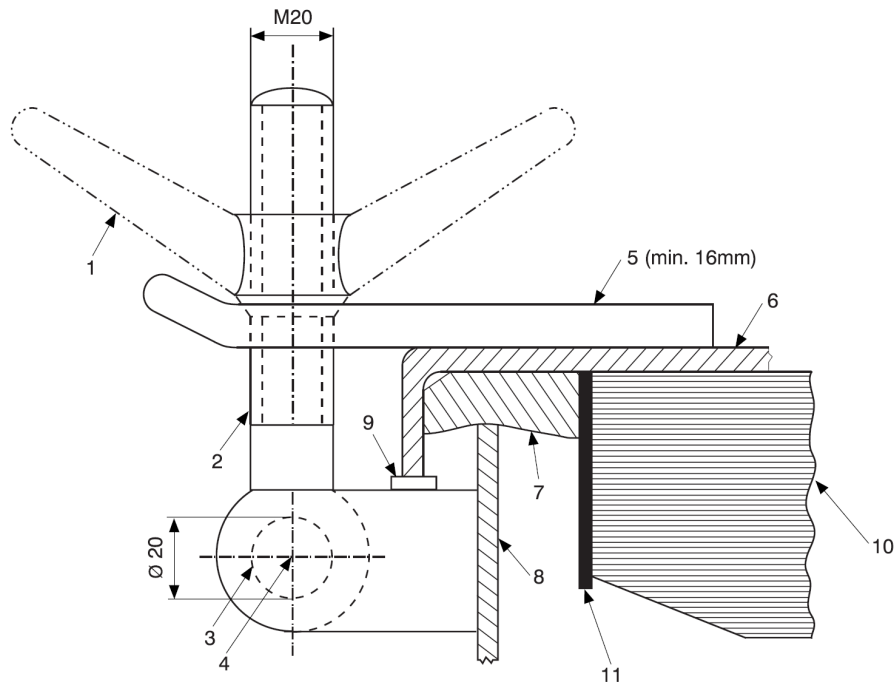

- 1) Butterfly nut
- 2) Bolt
- 3) Pin
- 4) Centre of pin
- 5) Fork (clamp) plate
- 6) Hatch cover
- 7) Gasket
- 8) Hatch coaming
- 9) Bearing pad welded on the bracket of a toggle bolt for metal to metal contact
- 10) Stiffener
- 11) Inner edge stiffener.

**Fig. 7**  
**Example of a primary securing method**



## SECTION 6 ARRANGEMENT OF HULL AND SUPERSTRUCTURE OPENINGS

### Symbols

For symbols not defined in this Section, refer to Ch 1, Sec 4.

$p$  = Lateral pressure for glasses, in kN/m<sup>2</sup>, defined in [3.3.2].

### 1 General

#### 1.1 Application

##### 1.1.1

The requirements of this Section apply to the arrangement of hull and superstructure openings excluding hatchways, for which the requirements in Ch 9, Sec 5 apply.

#### 1.2 Definitions

##### 1.2.1 Standard height of superstructure

The standard height of superstructure is that defined in Ch 1, Sec 4.

##### 1.2.2 Standard sheer

The standard sheer is that defined according to the International Load Line Convention, as amended.

##### 1.2.3 Exposed zones

Exposed zones are the boundaries of superstructures or deckhouses set in from the ship's side at a distance equal to or less than  $0.04B$ .

##### 1.2.4 Unexposed zones

Unexposed zones are the boundaries of deckhouses set in from the ship's side at a distance greater than  $0.04B$ .

### 2 External openings

#### 2.1 General

##### 2.1.1

Ref. SOLAS Reg.II-1/25-10 .1

*All external openings leading to compartments assumed intact in the damage analysis, which are below the final damage waterline, are required to be watertight.*

##### 2.1.2

Ref. SOLAS Reg.II-1/25-10 .2

*External openings required to be watertight in accordance with [2.1.1] are to be of sufficient strength and, except for cargo hatch covers, are to be fitted with indicators on the bridge.*

##### 2.1.3

No openings, be they permanent openings or temporary openings such as shell doors, windows or ports, are allowed on the side shell between the embarkation station of the marine evacuation system and the waterline in the lightest seagoing condition. Windows and side scuttles of the non-opening type are allowed if the Society's applicable criteria for fire integrity are complied with.

##### 2.1.4

Ref. SOLAS Reg.II-1/25-10 .5

*Other closing appliances which are kept permanently closed at sea to ensure the watertight integrity of external openings are to be provided with a notice affixed to each appliance to the effect that it is to be kept closed. Manholes fitted with closely bolted covers need not be so marked.*

## **2.2 Gangway, cargo and coaling ports**

### **2.2.1**

Ref. SOLAS Reg.II-1/17-1 & Reg.II-1/17 .10.1 & .10.2 and ILLC, as amended (Resolution MSC.143(77) Reg. 21(2))

Gangway, cargo and coaling ports fitted below the freeboard deck are to be of sufficient strength. They are to be effectively closed and secured watertight before the ship leaves port, and to be kept closed during navigation. Such ports are in no case to be so fitted as to have their lowest point below the deepest subdivision load line.

*Unless otherwise permitted by the Society, the lower edge of openings is not to be below a line drawn parallel to the freeboard deck at side, which is at its lowest point at least 230 mm above the upper edge of the uppermost load line.*

## **3 Side scuttles, windows and skylights**

### **3.1 General**

#### **3.1.1 Application**

The requirements in [3.1] to [3.4] apply to side scuttles and rectangular windows providing light and air, located in positions which are exposed to the action of sea and/or bad weather.

#### **3.1.2 Side scuttle definition**

Ref. ILLC, as amended (Resolution MSC.143(77) Reg. 23(2))

*Side scuttles are round or oval openings with an area not exceeding 0.16 m<sup>2</sup>. Round or oval openings having areas exceeding 0.16 m<sup>2</sup> are to be treated as windows.*

#### **3.1.3 Window definition**

Ref. ILLC, as amended (Resolution MSC.143(77) Reg. 23(3))

*Windows are rectangular openings generally, having a radius at each corner relative to the window size in accordance with recognised national or international standards, and round or oval openings with an area exceeding 0.16 m<sup>2</sup>.*

#### **3.1.4 Number of openings in the shell plating**

Ref. SOLAS Reg.II-1/17-1& Reg.II-1/17 .1

*The number of openings in the shell plating are to be reduced to the minimum compatible with the design and proper working of the ship.*

#### **3.1.5 Material and scantlings**

Ref. ILLC, as amended (Resolution MSC.143(77) Reg. 23(1))

*Side scuttles and windows together with their glasses, deadlights and storm covers, if fitted, are to be of approved design and substantial construction in accordance with, or equivalent to, recognised national or international standards.*

*Non-metallic frames are not acceptable.* The use of ordinary cast iron is prohibited for side scuttles below the freeboard deck.

#### **3.1.6 Means of closing and opening**

Ref. SOLAS Reg.II-1/17-1& Reg.II-1/17 .2

*The arrangement and efficiency of the means for closing any opening in the shell plating are to be consistent with its intended purpose and the position in which it is fitted is to be generally to the satisfaction of the Society.*

#### **3.1.7 Opening of side scuttles**

Ref. SOLAS Reg.II-1/17-1& Reg.II-1/17 .3.2

*All side scuttles, the sills of which are below the freeboard deck, are to be of such construction as to prevent effectively any person opening them without the consent of the Master of the ship.*

## **3.2 Opening arrangement**

### **3.2.1 General**

Ref. ILLC, as amended (Resolution MSC.143(77) Reg. 23(5))

*Side scuttles are not be fitted in such a position that their sills are below a line drawn parallel to the freeboard deck at side and having its lowest point 0.025B or 0.5 m, whichever is the greater distance, above the summer load waterline (or timber summer load waterline if assigned).*

### **3.2.2 Side scuttles below (1.4 + 0.025B) m above the water**

Ref. SOLAS Reg.II-1/17-1& Reg.II-1/17 .3.3.1 and .3.3.3

Where in 'tween decks the sills of any of the side scuttles are below a line drawn parallel to the freeboard deck at side and having its lowest point 1.4+0.025B m above the water when the ship departs from any port, all the side scuttles in that 'tween decks are to be closed watertight and locked before the ship leaves port, and they may not be opened before the ship arrives at the next port. In the application of this requirement, the appropriate allowance for fresh water may be made when applicable.

*For any ship that has one or more side scuttles so placed that the above requirements apply when it is floating at its deepest subdivision load line, the Society may indicate the limiting mean draught at which these side scuttles are to have their sills above the line drawn parallel to the freeboard deck at side, and having its lowest point 1.4+0.025B above the waterline corresponding to the limiting mean draught, and at which it is therefore permissible to depart from port without previously closing and locking them and to open them at sea under the responsibility of the Master during the voyage to the next port. In tropical zones as defined in the International Convention on Load Lines in force, this limiting draught may be increased by 0.3 m.*

### **3.2.3 Cargo spaces**

Ref. SOLAS Reg.II-1/17-1& Reg.II-1/17 .6.1 to .6.3

No side scuttles may be fitted in any spaces which are appropriated exclusively for the carriage of cargo or coal.

Side scuttles may, however, be fitted in spaces appropriated alternatively for the carriage of cargo or passengers, but they are to be of such construction as to prevent effectively any person opening them or their deadlights without the consent of the Master.

*If cargo is carried in such spaces, the side scuttles and their deadlights are to be closed watertight and locked before the cargo is shipped. The Society, at its discretion, may prescribe that the time of closing and locking is to be recorded in a log book.*

### **3.2.4 Non-opening type side scuttles**

Ref. ILLC, as amended (Resolution MSC.143(77) Reg. 23(6))

*Side scuttles are to be of the non-opening type where they become immersed by any intermediate stage of flooding or the final equilibrium waterline in any required damage case for ships subject to damage stability regulations.*

### **3.2.5 Manholes and flush scuttles**

Ref. ILLC, as amended (Resolution MSC.143(77) Reg. 18(1))

*Manholes and flush scuttles in positions 1 or 2, or within superstructures other than enclosed superstructures, are to be closed by substantial covers capable of being made watertight. Unless secured by closely spaced bolts, the covers are to be permanently attached.*

### **3.2.6 Automatic ventilating scuttles**

Ref. SOLAS Reg.II-1/17-1& Reg.II-1/17 .7

*Automatic ventilating side scuttles, fitted in the shell plating below the freeboard deck, are considered by the Society on a case by case basis.*

### **3.2.7 Window arrangement**

Ref. ILLC, as amended (Resolution MSC.143(77) Reg. 23(7))

*Windows are not to be fitted below the freeboard deck, in first tier end bulkheads or sides of enclosed*

*superstructures and in first tier deckhouses considered buoyant in the stability calculations or protecting openings leading below.*

### 3.2.8 Skylights

Ref. ILLC, as amended (Resolution MSC.143(77) Reg. 23(12))

*Fixed or opening skylights are to have glass thickness appropriate to their size and position as required for side scuttles and windows. Skylight glasses in any position are to be protected from mechanical damage and, where fitted in positions 1 or 2, to be provided with permanently attached robust deadlights or storm covers.*

## 3.3 Glasses

### 3.3.1 General

In general, toughened glasses with frames of special type are to be used in compliance with, or equivalent to, recognised national or international standards. The use of clear plate glasses is considered by the Society on a case by case basis.

### 3.3.2 Design loads

The design load is to be determined in accordance with the applicable requirements of Ch 9, Sec 4.

### 3.3.3 Materials

Toughened glasses are to be in accordance with ISO 1095 for side scuttles and ISO 3254 for windows.

### 3.3.4 Thickness of toughened glasses in side scuttles

The thickness of toughened glasses in side scuttles is to be not less than that obtained, in mm, from the following formula:

$$t = \frac{d}{358} \sqrt{p}$$

where:

$d$  = Side scuttle diameter, in mm.

### 3.3.5 Thickness of toughened glasses in rectangular windows

The thickness of toughened glasses in rectangular windows is to be not less than that obtained, in mm, from the following formula:

$$t = \frac{b}{200} \sqrt{\beta p}$$

where:

$\beta$  = Coefficient defined in Table 1.  $\beta$  is to be obtained by linear interpolation for intermediate values of  $a/b$

$a$  = Length, in mm, of the longer side of the window

$b$  = Length, in mm, of the shorter side of the window.

$a/b$	$\beta$
1.0	0.284
1.5	0.475
2.0	0.608
2.5	0.684
3.0	0.716
3.5	0.734
$\geq 4.0$	0.750

The Society may require both limitations on the size of rectangular windows and the use of glasses of increased thickness in way of front bulkheads which are particularly exposed to heavy sea.

### 3.4 Deadlight arrangement

#### 3.4.1 General

Ref. ILLC, as amended (Resolution MSC.143(77) Reg. 23(4))

Side scuttles to the following spaces are to be fitted with hinged inside deadlights:

- *spaces below freeboard deck*
- *spaces within the first tier of enclosed superstructures*
- *first tier deckhouses on the freeboard deck protecting openings leading below or considered buoyant in stability calculations.*

*Deadlights are to be capable of being closed and secured watertight if fitted below the freeboard deck and weathertight if fitted above.*

#### 3.4.2 Openings at the side shell in the second tier

Ref. ILLC, as amended (Resolution MSC.143(77) Reg. 23(8))

*Side scuttles and windows at the side shell in the second tier are to be provided with efficient, hinged inside deadlights capable of being closed and secured weathertight, if the superstructure protects direct access to an opening leading below or is considered buoyant in the stability calculations.*

#### 3.4.3 Openings set inboard in the second tier

Ref. ILLC, as amended (Resolution MSC.143(77) Reg. 23(9) and .23(10))

*Side scuttles and windows in side bulkheads set inboard from the side shell in the second tier which protect direct access below to spaces listed in [3.4.1], are to be provided with either hinged inside deadlights or, where they are accessible, permanently attached external storm covers of approved design and substantial construction capable of being closed and secured weathertight.*

Cabin bulkheads and doors in the second tier and above separating side scuttles and windows from a direct access leading below or the second tier considered buoyant in the stability calculations may be accepted in place of deadlights or storm covers fitted to the side scuttles and windows.

**Note:**

Deadlights in accordance with recognised standards are fitted to the inside of windows and side scuttles, while storm covers of comparable specifications to deadlights are fitted to the outside of windows, where accessible, and may be hinged or portable.

---e-n-d---of---N-o-t-e---

#### 3.4.4 Deckhouses on superstructures of less than standard height

Ref. ILLC, as amended (Resolution MSC.143(77) Reg. 23(11))

*Deckhouses situated on a raised quarter deck or on the deck of a superstructure of less than standard height may be regarded as being in the second tier as far as the requirements for deadlights are concerned, provided the height of the raised quarterdeck or superstructure is equal to or greater than the standard quarter deck height.*

#### 3.4.5 Openings protected by a deckhouse

Where an opening in a superstructure deck or in the top of a deckhouse on the freeboard deck which gives access to a space below the freeboard deck or to a space within an enclosed superstructure is protected by a deckhouse, then it is considered that only those side scuttles fitted in spaces which give direct access to an open stairway need to be fitted with deadlights.

## 4 Discharges

### 4.1 Arrangement of discharges

#### 4.1.1 Inlets and discharges

Ref. SOLAS Reg.II-1/17-1 & Reg.II-1/17 .9.1

*All inlets and discharges in the shell plating are to be fitted with efficient and accessible arrangements for preventing the accidental admission of water into the ship.*

#### **4.1.2 Inboard opening of ash-shoot, rubbish-shoot, etc.**

Ref. SOLAS Reg.II-1/17-1 & Reg.II-1/17 .11.1 and .11.2

The inboard opening of each ash-shoot, rubbish-shoot, etc. is to be fitted with an efficient cover.

*If the inboard opening is situated below the freeboard deck, the cover is to be watertight, and in addition an automatic non-return valve is to be fitted in the shoot in an easily accessible position above the deepest subdivision load line. When the shoot is not in use, both the cover and the valve are to be kept closed and secured.*

### **4.2 Arrangement of garbage chutes**

#### **4.2.1 Inboard end above the waterline**

Ref. ILLC, as amended (Resolution MSC.143(77) Reg. 22-1(1, b))

*The inboard end is to be located above the waterline formed by an 8.5° heel, to port or starboard, at a draft corresponding to the assigned summer freeboard, but not less than 1000 mm above the summer load waterline.*

*Where the inboard end of the garbage chute exceeds 0.01L above the summer load waterline, valve control from the freeboard deck is not required, provided the inboard gate valve is always accessible under service conditions.*

#### **4.2.2 Inboard end below the waterline**

Ref. ILLC, as amended (Resolution MSC.143(77) Reg. 22-1(4))

Where the inboard end of a garbage chute is below the waterline corresponding to the deepest draught after damage in a ship of more than 100 m in length, then:

- *the inboard end hinged cover/valve is to be watertight*
- *the valve is to be a screw-down non-return valve fitted in an easily accessible position above the deepest subdivision load line*
- *the screw-down non-return valve is to be controlled from a position above the freeboard deck and provided with open/shut indicators. The valve control is to be clearly marked: «Keep closed when not in use».*

#### **4.2.3 Gate valves**

Ref. ILLC, as amended (Resolution MSC.143(77) Reg. 22-1(1, a))

*For garbage chutes, two gate valves controlled from the working deck of the chute may be accepted instead of a non-return valve with a positive means of closing it from a position above the freeboard deck. In addition, the lower gate valve is to be controlled from a position above the freeboard deck. An interlock system between the two valves is to be arranged.*

The distance between the two gate valves is to be adequate to allow the smooth operation of the interlock system.

#### **4.2.4 Hinged cover and discharge flap**

Ref. ILLC, as amended (Resolution MSC.143(77) Reg. 22-1(1, c))

The upper and lower gate valves, as required in [4.2.3], may be replaced by a hinged weathertight cover at the inboard end of the chute together with a discharge flap.

*The cover and discharge flap are to be arranged with an interlock so that the flap cannot be operated until the hopper cover is closed.*

#### **4.2.5 Marking of valve and hinged cover**

Ref. ILLC, as amended (Resolution MSC.143(77) Reg. 22-1(3))

*The controls for the gate valves and/or hinged covers are to be clearly marked: «Keep closed when not in use».*

### **4.3 Scantlings of garbage chutes**

#### **4.3.1 Material**

The chute is to be constructed of steel. Other equivalent materials are considered by the Society on a case by case basis.

#### **4.3.2 Wall thickness**

The wall thickness of the chute up to and including the cover is to be not less than that obtained, in mm, from

Table 2.

<i>External diameter d, in mm</i>	<i>Thickness, in mm</i>
$d \leq 80$	7.0
$80 < d < 180$	$7.0 + 0.03(d - 80)$
$180 \leq d \leq 220$	$10.0 + 0.063(d - 180)$
$d > 220$	12.5

## 5 Freeing ports

### 5.1 General provisions

#### 5.1.1 General

Ref. ILLC, as amended (Resolution MSC.143(77) Reg. 24 (1, a) and Reg.3 (15))

Where bulwarks on the weather portions of freeboard or superstructure decks form wells, ample provision is to be made for rapidly freeing the decks of water and for draining them.

*A well is any area on the deck exposed to the weather, where water may be entrapped. Wells are considered to be deck areas bounded on four sides by deck structures; however, depending on their configuration, deck areas bounded on three or even two sides by deck structures may be deemed wells.*

#### 5.1.2 Freeing port areas

Ref. ILLC, as amended (Resolution MSC.143(77) Reg. 24)

*The minimum required freeing port areas in bulwarks on the freeboard deck are specified in Table 3.*

<i>Ship types or ship particulars</i>	<i>Area A of freeing ports, in m<sup>2</sup></i>	<i>Applicable requirement</i>
Type B-100	$0.33\ell_B h_B$	[5.5.2]
Type B-60	$0.25\ell_B h_B$	[5.5.1]
Ships fitted with a trunk included in freeboard calculation and/ or breadth $\geq 0.6B$	$0.33\ell_B h_B$	[5.3.1]
Ships fitted with a trunk not included in freeboard calculation and/or continuous or substantially continuous hatch coamings	$A_2$	[5.3.1]
Ships fitted with non-continuous trunk and/ or hatch coamings	$A_3$	[5.3.2]
Ships fitted with open superstructure	$A_S$ for superstructures	[5.4.2]
	$A_W$ for wells	[5.4.3]
Other ships	$A_I$	[5.2.1]
where:		
$\ell_B$ = Length, in m, of bulwark in a well at one side of the ship		
$h_B$ = Mean height, in m, of bulwark in a well of length $\ell_B$ .		

#### 5.1.3 Freeing port arrangement

Ref. ILLC, as amended (Resolution MSC.143(77) Reg. 24 (5))

Where a sheer is provided, two thirds of the freeing port area required is to be provided in the half of the well nearer the lowest point of the sheer curve.

One third of the freeing port area required is to be evenly spread along the remaining length of the well. With zero or little sheer on the exposed freeboard deck or an exposed superstructure deck the freeing port area is to be evenly spread along the length of the well.

However, bulwarks may not have substantial openings or accesses near the breaks of superstructures, unless they are effectively detached from the superstructure sides.

#### 5.1.4 Freeing port positioning

Ref. ILLC, as amended (Resolution MSC.143(77) Reg. 24 (5) and 24 (6))

The lower edge of freeing ports is to be as near the deck as practicable.

*All the openings in the bulwark are to be protected by rails or bars spaced approximately 230 mm apart.*

### 5.1.5 Freeing port closures

Ref. ILLC, as amended (Resolution MSC.143(77) Reg. 24 (6))

*If shutters or closures are fitted to freeing ports, ample clearance is to be provided to prevent jamming. Hinges are to have pins or bearings of non-corrodible material. If shutters are fitted with securing appliances, these appliances are to be of approved construction.*

## 5.2 Freeing port area in a well not adjacent to a trunk or hatchways

### 5.2.1 Freeing port area

Ref. ILLC, as amended (Resolution MSC.143(77) Reg. 24 (1, b and c))

*Where the sheer in way of the well is standard or greater than the standard, the freeing port area on each side of the ship for each well is to be not less than that obtained, in m<sup>2</sup>, in Table 4.*

*In ships with no sheer, the above area is to be increased by 50%. Where the sheer is less than the standard, the percentage of increase is to be obtained by linear interpolation.*

Table 4 Freeing port area in a well not adjacent to a trunk or hatchways		
Location	Area $A_1$ of freeing ports, in m <sup>2</sup>	
	$\ell_B \leq 20$	$\ell_B > 20$
Freeboard deck and raised quarterdecks	$0.7 + 0.035\ell_B + A_C$	$0.07\ell_B + A_C$
Superstructure decks	$0.35 + 0.0175\ell_B + 0.5A_C$	$0.035\ell_B + 0.5A_C$
where:		
$\ell_B$ = Length, in m, of bulwark in the well, but need in no case to be taken as greater than $0.7L_{LL}$		
$A_C$ = Area, in m <sup>2</sup> , to be taken, with its sign, equal to:		
$h_B$ = Mean height, in m, of the bulwark in a well of length $\ell_B$ .		

### 5.2.2 Minimum freeing port area for a deckhouse having breadth not less than 0.8B

Ref. ILLC, as amended (Resolution MSC.143(77) Reg. 24 (1, d))

*Where a flush deck ship is fitted amidships with a deckhouse having breadth not less than 0.8 B and the width of the passageways along the side of the ship less than 1.5 m, the freeing port area is to be calculated for two separate wells, before and abaft the deckhouse. For each of these wells, the freeing port area is to be obtained from Table 4, where  $\ell_B$  is to be taken equal to the actual length of the well considered.*

### 5.2.3 Minimum freeing port area for screen bulkhead

Ref. ILLC, as amended (Resolution MSC.143(77) Reg. 24 (1, e))

*Where a screen bulkhead is fitted across the full breadth of the ship at the fore end of a midship deckhouse, the weather deck is to be considered as divided into two wells, irrespective of the width of the deckhouse, and the freeing port area is to be obtained in accordance with [5.1.2].*

## 5.3 Freeing port area in a well contiguous to a trunk or hatchways

### 5.3.1 Freeing area for continuous trunk or continuous hatchway coaming

Ref. ILLC, as amended (Resolution MSC.143(77) Reg. 24 (2))

*Where the ship is fitted with a continuous trunk not included in the calculation of freeboard or where continuous or substantially continuous hatchway side coamings are fitted between detached superstructures, the freeing port area is to be not less than that obtained, in m<sup>2</sup>, from Table 5.*

Table 5 Freeing port area in a well contiguous to a continuous trunk or hatchway	
Breadth $B_H$ , in m, of hatchway or trunk	Area $A_2$ of freeing ports, in m <sup>2</sup>



$B_H \leq 0.4B$	$0.2\ell_B h_B$
$0.4B < B_H < 0.75B$	$\left[0.2 - 0.28\left(\frac{B_H}{B} - 0.4\right)\right]\ell_B h_B$
$B_H \geq 0.75B$	$0.1\ell_B h_B$
where: $\ell_B$ = Length, in m, of bulwark in a well at one side of the ship $h_B$ = Mean height, in m, of bulwark in a well of length $\ell_B$ .	

Where the ship is fitted with a continuous trunk having breadth not less than  $0.6B$ , included in the calculation of freeboard, and where open rails on the weather parts of the freeboard deck in way of the trunk for at least half the length of these exposed parts are not fitted, the freeing port area in the well contiguous to the trunk is to be not less than 33% of the total area of the bulwarks.

### 5.3.2 Freeing area for non-continuous trunk or hatchway coaming

Ref. ILLC, as amended (Resolution MSC.143(77) Reg. 24 (3))

Where the free flow of water across the deck of the ship is impeded due to the presence of a non-continuous trunk, hatchway coaming or deckhouse in the whole length of the well considered, the freeing port area in the bulwark of this well is to be not less than that obtained, in  $m^2$ , from Table 6.

Table 6 Freeing port area in a well contiguous to a non-continuous trunk or hatchway	
Free flow area $f_P$ , in $m^2$	Freeing port area $A_3$ , in $m^2$
$f_P \leq A_1$	$A_2$
$A_1 < f_P < A_2$	$A_1 + A_2 - f_P$
$f_P \geq A_2$	$A_1$
where: $f_P$ = Free flow area on deck, equal to the net area of gaps between hatchways, and between hatchways and superstructures and deckhouses up to the actual height of the bulwark $A_1$ = Area of freeing ports, in $m^2$ , to be obtained from Table 4 $A_2$ = Area of freeing ports, in $m^2$ , to be obtained from Table 5.	

## 5.4 Freeing port area in an open space within superstructures

### 5.4.1 General

Ref. ILLC, as amended (Resolution MSC.143(77) Reg. 24 (4))

In ships having superstructures on the freeboard or superstructure decks, which are open at either or both ends to wells formed by bulwarks on the open decks, adequate provision for freeing the open spaces within the superstructures is to be provided.

### 5.4.2 Freeing port area for open superstructures

Ref. ILLC, as amended (Resolution MSC.143(77) Reg. 24 (4))

The freeing port area on each side of the ship for the open superstructure is to be not less than that obtained, in  $m^2$ , from the following formula:

$$A_S = A_1 C_{SH} \left[ 1 - \left( \frac{\ell_W}{\ell_T} \right)^2 \right] \left( \frac{b_0 h_s}{2\ell_T h_W} \right)$$

where:

$\ell_T$  = Total well length, in m, to be taken equal to:

$$\ell_T = \ell_W + \ell_S$$

$\ell_W$  = Length, in m, of the open deck enclosed by bulwarks

$\ell_S$  = Length, in m, of the common space within the open superstructures

$A_1$  = Freeing port area, in  $m^2$ , required for an open well of length  $\ell_T$ , in accordance with Table 4, where  $A_C$  is to be taken equal to zero

$C_{SH}$  = Coefficient which accounts for the absence of sheer, if applicable, to be taken equal to:

$C_{SH} = 1.0$  in the case of standard sheer or sheer greater than standard sheer

$C_{SH} = 1.5$  in the case of no sheer

$b_0$  = Breadth, in m, of the openings in the end bulkhead of enclosed superstructures

$h_S$  = Standard superstructure height, in m, defined in [1.2.1]

$h_W$  = Distance, in m, of the well deck above the freeboard deck.

### 5.4.3 Freeing port area for open well

Ref. ILLC, as amended (Resolution MSC.143(77) Reg. 24 (4))

The freeing port area on each side of the ship for the open well is to be not less than that obtained, in  $m^2$ , from the following formula:

$$A_W = A_1 c_{SH} \left( \frac{h_S}{2h_W} \right)$$

$A_1$  = Freeing port area, in  $m^2$ , required for an open well of length  $\ell_W$ , in accordance with Table 4

$c_{SH}$ ,  $h_S$ ,  $h_W$ ,  $\ell_W$ : Defined in [5.4.2].

The resulting freeing port areas for the open superstructure  $A_S$  and for the open well  $A_W$  are to be provided along each side of the open space covered by the open superstructure and each side of the open well, respectively.

## 5.5 Freeing port area in bulwarks of the freeboard deck for ships of types B-100 and B-60

### 5.5.1 Freeing arrangement for type B-60

For type B-60 ships, the freeing port area in the lower part of the bulwarks of the freeboard deck is to be not less than 25% of the total area of the bulwarks in the well considered.

The upper edge of the sheer strake is to be kept as low as possible.

### 5.5.2 Freeing arrangement for type B-100 ships with trunks

For type B-100 ships, open rails are to be fitted on the weather parts of the freeboard deck in way of the trunk for at least half the length of these exposed parts.

Alternatively, if a continuous bulwark is fitted, the freeing port area in the lower part of the bulwarks of the freeboard deck is to be not less than 33% of the total area of the bulwarks in the well considered.

## 6 Machinery space openings

### 6.1 Engine room skylights

#### 6.1.1

Engine room skylights in positions 1 or 2 are to be properly framed, securely attached to the deck and efficiently enclosed by steel casings of suitable strength. Where the casings are not protected by other structures, their strength will be considered by the Society on a case by case basis.

### 6.2 Closing devices

#### 6.2.1 Machinery casings

Ref. ILLC, as amended (Resolution MSC.143(77) Reg. 17 (1) and 12 (1))

Openings in machinery space casings in positions 1 or 2 are to be fitted with doors of steel or other equivalent materials, permanently and strongly attached to the bulkhead, and framed, stiffened and fitted so that the whole structure is of equivalent strength to the unpierced bulkhead and weathertight when closed. The doors are to be capable of being operated from both sides and generally to open outwards to give additional protection against wave impact.

Other openings in such casings are to be fitted with equivalent covers, permanently attached in their proper position.

#### 6.2.2 Height of the sill of the door

Ref. ILLC, as amended (Resolution MSC.143(77) Reg. 17 (1 and 2))

The height of the sill of the door is to be not less than:

- 600 mm above the deck if in position 1
- 380 mm above the deck if in position 2
- 230 mm in all other cases.

### **6.2.3 Double doors**

Ref. ILLC, as amended (Resolution MSC.143(77) Reg. 17 (1 and 2))

*Where casings are not protected by other structures, double doors (i.e. inner and outer doors) are required for ships assigned freeboard less than that based on Table B of the International Load Line Convention, as amended. An inner sill of 230 mm in conjunction with the outer sill of 600 mm is to be provided.*

### **6.2.4 Fiddly openings**

Ref. ILLC, as amended (Resolution MSC.143(77) Reg. 17 (5))

*Fiddly openings are to be fitted with strong covers of steel or other equivalent material permanently attached in their proper positions and capable of being secured weathertight.*

## **6.3 Coamings**

### **6.3.1**

Ref. ILLC, as amended (Resolution MSC.143(77) Reg. 17 (3))

Coamings of any fiddly, funnel or machinery space ventilator in an exposed position on the freeboard deck or superstructure deck are to be as high above the deck as is reasonable and practicable.

*In general, ventilators necessary to continuously supply the machinery space and, on demand, the emergency generator room are to have coamings whose height is in compliance with [8.1.3], but need not be fitted with weathertight closing appliances.*

### **6.3.2**

Ref. ILLC, as amended (Resolution MSC.143(77) Reg. 17 (4))

*Where, due to the ship's size and arrangement, this is not practicable, lesser heights for machinery space and emergency generator room ventilator coamings, fitted with weathertight closing appliances in accordance with [8.1.2], may be permitted by the Society in combination with other suitable arrangements to ensure an uninterrupted, adequate supply of ventilation to these spaces.*

## **7 Companionway**

### **7.1 General**

#### **7.1.1 Openings in freeboard deck**

Ref. ILLC, as amended (Resolution MSC.143(77) Reg. 18 (2))

*Openings in freeboard deck other than hatchways, machinery space openings, manholes and flush scuttles are to be protected by an enclosed superstructure or by a deckhouse or companionway of equivalent strength and weathertightness.*

#### **7.1.2 Openings in superstructures**

Ref. ILLC, as amended (Resolution MSC.143(77) Reg. 18 (2))

*Openings in an exposed superstructure deck or in the top of a deckhouse on the freeboard deck which give access to a space below the freeboard deck or a space within an enclosed superstructure are to be protected by an efficient deckhouse or companionway.*

#### **7.1.3 Openings in superstructures having height less than standard height**

Ref. ILLC, as amended (Resolution MSC.143(77) Reg. 18 (3))

*Openings in the top of a deckhouse on a raised quarterdeck or superstructure of less than standard height, having a height equal to or greater than the standard quarterdeck height are to be provided with an acceptable means of closing but need not be protected by an efficient deckhouse or companionway provided the height of the deckhouse is at least the height of the superstructure. Openings in the top of the deckhouse on a deckhouse of less than a standard superstructure height may be treated in a similar manner.*

## 7.2 Scantlings

### 7.2.1

Companionways on exposed decks protecting openings leading into enclosed spaces are to be of steel and strongly attached to the deck and are to have adequate scantlings.

## 7.3 Closing devices

### 7.3.1 Doors

Ref. ILLC, as amended (Resolution MSC.143(77) Reg. 18 (2))

*Doorways in deckhouses or companionways leading to or giving access to spaces below the freeboard deck or to enclosed superstructures are to be fitted with weathertight doors. The doors are to be made of steel, to be capable of being operated from both sides and generally to open outwards to give additional protection against wave impact.*

Alternatively, if stairways within a deckhouse are enclosed within properly constructed companionways fitted with weathertight doors, the external door need not be weathertight.

Where the closing appliances of access openings in superstructures and deckhouses are not weathertight, interior deck openings are to be considered exposed, i.e. situated in the open deck.

### 7.3.2 Height of sills

Ref. ILLC, as amended (Resolution MSC.143(77) Reg. 18 (4 to 6))

The height above the deck of sills to the doorways in companionways is to be not less than:

- 600 mm in position 1
- 380 mm in position 2.

Where access is provided from the deck above as an alternative to access from the freeboard deck, the height of the sills into the bridge or poop is to be 380 mm. This also applies to deckhouses on the freeboard deck.

*Where access is not provided from above, the height of the sills to doorways in deckhouses on the freeboard deck is to be 600 mm.*

## 8 Ventilators

### 8.1 Closing appliances

#### 8.1.1 General

Ref. ILLC, as amended (Resolution MSC.143(77) Reg. 19 (4))

*Ventilator openings are to be provided with efficient weathertight closing appliances of steel or other equivalent material.*

#### 8.1.2 Closing appliance exemption

Ref. ILLC, as amended (Resolution MSC.143(77) Reg. 19 (3))

Ventilators need not be fitted with closing appliances, unless specifically required by the Society, if the coamings extend for more than:

- 4.5 m above the deck in position 1
- 2.3 m above the deck in position 2.

#### 8.1.3 Closing appliances for ships of not more than 100 m in length

Ref. ILLC, as amended (Resolution MSC.143(77) Reg. 19 (4))

*In ships of not more than 100 m in length, the closing appliances are to be permanently attached to the ventilator coamings.*

#### 8.1.4 Closing appliances for ships of more than 100 m in length

Ref. ILLC, as amended (Resolution MSC.143(77) Reg. 19 (4))

*Where, in ships of more than 100 m in length, the closing appliances are not permanently attached, they are to*

*be conveniently stowed near the ventilators to which they are to be fitted.*

### 8.1.5 Ventilation of machinery spaces and emergency generator room

In order to satisfactorily ensure, in all weather conditions:

- the continuous ventilation of machinery spaces,
- and, when necessary, the immediate ventilation of the emergency generator room,

the ventilators serving such spaces are to comply with [8.1.2], i.e. their openings are to be so located that they do not require closing appliances.

### 8.1.6 Reduced height of ventilator coamings for machinery spaces and emergency generator room

Where, due to the ship's size and arrangement, the requirements in [8.1.5] are not practicable, lesser heights may be accepted for machinery space and emergency generator room ventilator coamings fitted with weathertight closing appliances in accordance with [8.1.1], [8.1.3] and [8.1.4] in combination with other suitable arrangements, such as separators fitted with drains, to ensure an uninterrupted, adequate supply of ventilation to these spaces.

### 8.1.7 Closing arrangements of ventilators led overboard or through enclosed superstructures

Closing arrangements of ventilators led overboard to the ship side or through enclosed superstructures are considered by the Society on a case by case basis. If such ventilators are led overboard more than 4.5 m above the freeboard deck, closing appliances may be omitted provided that satisfactory baffles and drainage arrangements are fitted.

## 8.2 Coamings

### 8.2.1 General

Ref. ILLC, as amended (Resolution MSC.143(77) Reg. 19 (1 and 2))

Ventilators in positions 1 or 2 to spaces below freeboard decks or decks of enclosed superstructures are to have coamings of steel or other equivalent material, substantially constructed and efficiently connected to the deck.

*Ventilators passing through superstructures other than enclosed superstructures are to have substantially constructed coamings of steel or other equivalent material at the freeboard deck.*

### 8.2.2 Scantlings

The scantlings of ventilator coamings exposed to the weather are to be not less than those obtained from Table 7.

In exposed locations or for the purpose of compliance with buoyancy calculations, the height of coamings may be required to be increased to the satisfaction of the Society.

<i>Feature</i>	<i>Scantlings</i>
Height of the coaming, in mm, above the deck	$h = 900$ in position 1 $h = 760$ in position 2
Thickness of the coaming, in mm <sup>(1)</sup>	$t = 5.5 + 0.01 d_V$ with $7.5 \leq t \leq 10$
Support	If $h > 900$ mm, the coaming is to be suitably stiffened or supported by stays.
where:	
$d_V$ = External diameter of the ventilator, in mm.	
<sup>(1)</sup> Where the height of the ventilator exceeds the height $h$ , the thickness of the coaming may be gradually reduced, above that height, to a minimum of 6.5 mm.	

## 9 Tank cleaning openings

### 9.1 General

#### 9.1.1

Ullage plugs, sighting ports and tank cleaning openings may not be arranged in enclosed spaces.



# **Chapter 10**

## **Hull Outfitting**

---

Section 1 Rudder and Manoeuvring Arrangement

Section 2 Bulwarks and Guard Rails

Section 3 Equipment





## SECTION 1 RUDDER AND MANOEUVRING ARRANGEMENT

### Symbols

For symbols not defined in this Section, refer to Ch 1, Sec 4.

$C_R$  = Rudder force, in N

$Q_R$  = Rudder torque, in N.m

$A$  = Total movable area of the rudder, in m<sup>2</sup>, measured at the mid-plane of the rudder

For nozzle rudders,  $A$  is not to be taken less than 1.35 times the projected area of the nozzle.

$A_t$  = Area equal to  $A$  + area of a rudder horn, if any, in m<sup>2</sup>

$A_f$  = Portion of rudder area located ahead of the rudder stock axis, in m<sup>2</sup>

$b$  = Mean height of rudder area, in m

$c$  = Mean breadth of rudder area, in m, see Fig 1

$\Lambda$  = Aspect ratio of rudder area  $A_t$ , taken equal to:

$$\Lambda = \frac{b^2}{A_t}$$

$V_0$  = Maximum ahead speed, in knots, as defined in Ch 1, Sec 4. If this speed is less than 10,  $V_0$  is to be replaced by:

$$V_{\min} = \frac{(V_0 + 20)}{3}$$

$V_a$  = Maximum astern speed, in knots, to be taken not less than  $0.5V_0$ . For greater astern speeds special evaluation of rudder force and torque as a function of the rudder angle may be required. If no limitations for the rudder angle at astern condition is stipulated, the factor  $K_2$  is not to be taken less than given in Table 1 for astern condition.

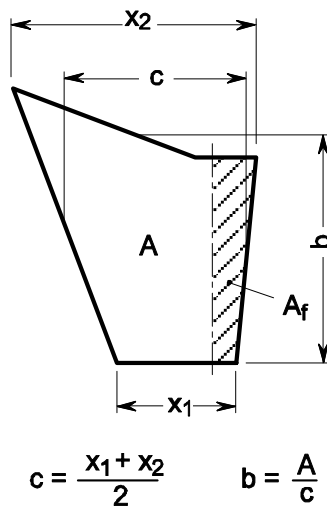

**Fig. 1**  
**Dimensions of rudder**

## 1 General

### 1.1 Manoeuvring arrangement

#### 1.1.1

The manoeuvring arrangement includes all parts from the rudder and steering gear to the steering position necessary for steering the ship.

#### 1.1.2

Rudder stock, rudder coupling, rudder bearings and the rudder body are dealt with in this Section. The steering

gear is to comply with the appropriate Rules of the Society.

### 1.1.3

The steering gear compartment shall be readily accessible and, as far as practicable, separated from the machinery space.

**Note:**

Concerning the use of non-magnetisable material in the wheel house in way of a magnetic compass, the requirements of the national Administration concerned are to be observed.

---e-n-d---of---N-o-t-e---

## 1.2 Structural details

### 1.2.1

Effective means are to be provided for supporting the weight of the rudder body without excessive bearing pressure, e.g. by a rudder carrier attached to the upper part of the rudder stock. The hull structure in way of the rudder carrier is to be suitably strengthened.

### 1.2.2

Suitable arrangements are to be provided to prevent the rudder from lifting.

### 1.2.3

Connections of rudder blade structure with solid parts in forged or cast steel, which are used as rudder stock housing, are to be suitably designed to avoid any excessive stress concentration at these areas.

### 1.2.4

The rudder stock is to be carried through the hull either enclosed in a watertight trunk, or glands are to be fitted above the deepest load waterline, to prevent water from entering the steering gear compartment and the lubricant from being washed away from the rudder carrier. If the top of the rudder trunk is below the deepest waterline two separate stuffing boxes are to be provided.

## 1.3 (void)

## 1.4 Materials

### 1.4.1

For materials for rudder stock, pintles, coupling bolts etc. refer to the Society's Rules for Materials.

### 1.4.2

In general, materials having  $R_{eH}$  of less than 200 N/mm<sup>2</sup> and  $R_m$  of less than 400 N/mm<sup>2</sup> or more than 900 N/mm<sup>2</sup> are not to be used for rudder stocks, pintles, keys and bolts. The requirements of this Section are based on a with  $R_{eH}$  of 235 N/mm<sup>2</sup>. If material is used having a  $R_{eH}$  differing from 235 N/mm<sup>2</sup>, the material factor  $k_r$  is to be determined as follows:

$$k_r = \left( \frac{235}{R_{eH}} \right)^{0.75} \quad \text{for } R_{eH} > 235$$

$$k_r = \frac{235}{R_{eH}} \quad \text{for } R_{eH} \leq 235$$

where:

$R_{eH}$  = Minimum yield stress of material used, in N/mm<sup>2</sup>.  $R_{eH}$  is not to be taken greater than 0.7 $R_m$  or 450 N/mm<sup>2</sup>, whichever is less.

### 1.4.3

Before significant reductions in rudder stock diameter due to the application of steels with  $R_{eH}$  exceeding 235 N/mm<sup>2</sup> are accepted, the Society may require the evaluation of the elastic rudder stock deflections. Large deflections should be avoided in order to avoid excessive edge pressures in way of bearings.

### 1.4.4

The permissible stresses given in [5.1] are applicable for normal strength steel. When higher strength steels are used, higher values may be used for the permissible stresses, on a case by case basis.

## 2 Rudder force and torque

### 2.1 Rudder force and torque for normal rudders

#### 2.1.1

The rudder force is to be determined, in N, according to the following formula:

$$C_R = 132 AV^2 \kappa_1 \kappa_2 \kappa_3 \kappa_t$$

where:

$V = V_0$  for ahead condition  
 $V_a$  for astern condition

$\kappa_1 =$  Coefficient, depending on the aspect ratio  $\Lambda$ , taken equal to:  $\kappa_1 = (\Lambda + 2)/3$ , where  $\Lambda$  need not be taken greater than 2

$\kappa_2 =$  Coefficient, depending on the type of the rudder and the rudder profile according to Table 1

Profile / type of rudder	$\kappa_2$	
	Ahead	Astern
NACA-00 series Göttingen profiles	1.10	0.80
Flat side profiles	1.10	0.90
Mixed profiles (e. g. HSV A)	1.21	0.90
Hollow profiles	1.35	0.90
High lift rudders	1.70	to be specially considered; if not known: 1.30
Fish tail	1.40	0.80
Single plate	1.00	1.00

$\kappa_3 =$  Coefficient, depending on the location of the rudder, taken equal to:

$\kappa_3 = 0.80$  for rudders outside the propeller jet

$\kappa_3 = 1.00$  elsewhere, including also rudders within the propeller jet

$\kappa_3 = 1.15$  for rudders aft of the propeller nozzle

$\kappa_t =$  Coefficient equal to 1.0 for rudders behind propeller. Where a thrust coefficient  $C_{Th} > 1.0$ , the Society may consider a coefficient  $K1$  different from 1.0, on a case by case basis.

#### 2.1.2

The rudder torque, in Nm, is to be determined by the following formula:

$$Q_R = C_R r$$

where:

$r =$  Lever of the force  $C_R$ , in m, taken equal to:

$r = c(\alpha - k_{bc})$ , without being less than  $0.1c$  for ahead condition

$\alpha =$  Coefficient taken equal to:

$\alpha = 0.33$  for ahead condition

$\alpha = 0.66$  for astern condition (general)

$\alpha = 0.75$  for astern condition (hollow profiles)

For parts of a rudder behind a fixed structure such as a rudder horn:

$\alpha = 0.25$  for ahead condition

$\alpha = 0.55$  for astern condition

For high lift rudders  $\alpha$  is to be specially considered. If not known,  $\alpha = 0.40$  may be used for the ahead condition

$k_{bc}$  = Balance factor as follows:

$$k_{bc} = \frac{A_f}{A}$$

$k_{bc} = 0.08$  for unbalanced rudders

### 2.1.3

Effects of the provided type of rudder/profile on choice and operation of the steering gear are to be observed.

## 2.2 Rudder force and torque for rudder blades with cut-outs (semi-spade rudders)

### 2.2.1

The total rudder force  $C_R$  is to be calculated according to [2.1.1]. The pressure distribution over the rudder area, upon which the determination of rudder torque and rudder blade strength are to be based, is to be obtained as follows:

- the rudder area may be divided into two rectangular or trapezoidal parts with areas  $A_1$  and  $A_2$ , see Fig 2.
- the resulting force, in N, of each part may be taken as:

$$C_{R1} = C_R \frac{A_1}{A}$$

$$C_{R2} = C_R \frac{A_2}{A}$$

### 2.2.2

The resulting torque, in N.m, of each part is to be taken as:

$$Q_{R1} = C_{R1} r_1$$

$$Q_{R2} = C_{R2} r_2$$

where:

$$r_1 = c_1(\alpha - k_{b1}), \text{ in m}$$

$$r_2 = c_2(\alpha - k_{b2}), \text{ in m}$$

$$k_{b1} = \frac{A_{1f}}{A_1}$$

$$k_{b2} = \frac{A_{2f}}{A_2}$$

$A_{1f}, A_{2f}$  = As defined in Fig 2

$$c_1 = \frac{A_1}{b_1}$$

$$c_2 = \frac{A_2}{b_2}$$

$b_1, b_2$  = Mean heights of the partial rudder areas  $A_1$  and  $A_2$  (see Fig 2).

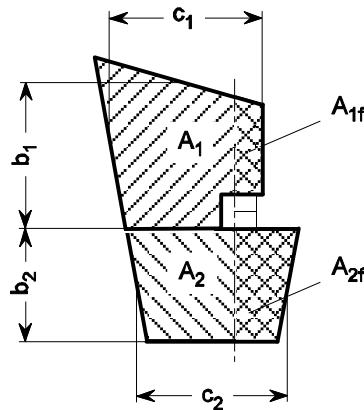

**Fig. 2**  
Areas  $A_1$  and  $A_2$

### 2.2.3

The total rudder torque, in N.m, is to be determined according to the following formulae:

$$Q_R = Q_{R1} + Q_{R2}, \text{ without being less than } Q_{R\min} = C_R r_{1,2\min}$$

where:

$$r_{1,2\min} = \frac{0.1}{A} (c_1 A_1 + c_2 A_2), \text{ in m.}$$

## 3 Scantlings of the rudder stock

### 3.1 Rudder stock diameter

#### 3.1.1

The diameter of the rudder stock, in mm, for transmitting the rudder torque is not to be less than:

$$D_t = 4.2 \sqrt[3]{Q_R k_r}$$

where:

$Q_R$  = As defined in [2.1.2], [2.2.2] and [2.2.3]

The related torsional stress, in  $\text{N/mm}^2$ , is:

$$\tau_t = \frac{68}{k_r}$$

where:

$k_r$  = As defined in [1.4.2] and [1.4.3].

#### 3.1.2

The diameter of the rudder stock determined according to [3.1.1] is decisive for the steering gear, the stopper and the locking device.

#### 3.1.3

In case of mechanical steering gear the diameter of the rudder stock in its upper part which is only intended for transmission of the torsional moment from the auxiliary steering gear may be  $0.9D_t$ . The length of the edge of the quadrangle for the auxiliary tiller must not be less than  $0.77D_t$  and the height not less than  $0.8D_t$ .

#### 3.1.4

The rudder stock is to be secured against axial sliding. The degree of the permissible axial clearance depends

on the construction of the steering engine and on the bearing.

## 3.2 Strengthening of rudder stock

### 3.2.1

If the rudder is so arranged that additional bending stresses occur in the rudder stock, the stock diameter has to be suitably increased. The increased diameter is, where applicable, decisive for the scantlings of the coupling.

For the increased rudder stock diameter the equivalent stress of bending and torsion, in  $\text{N/mm}^2$ , is not to exceed the following value:

$$\sigma_v = \sqrt{\sigma_b^2 + 3\tau^2} \leq \frac{118}{k_r}$$

where:

$\sigma_b$  = Bending stress, in  $\text{N/mm}^2$ , equal to:

$$\sigma_b = \frac{10.2 M_b}{D_1^3}$$

$M_b$  = Bending moment at the neck bearing, in  $\text{N.m}$

$\tau$  = Torsional stress, in  $\text{N/mm}^2$ , equal to:

$$\tau = \frac{5.1 Q_R}{D_1^3}$$

$D_1$  = Increased rudder stock diameter, in cm, equal to:

$$D_1 = 0.1 D_t \sqrt[6]{1 + \frac{4}{3} \left( \frac{M_b}{Q_R} \right)^2}$$

$Q_R$  = As defined in [2.1.2], [2.2.2] and [2.2.3]

$D_t$  = As defined in [3.1.1].

**Note:**

Where a double-piston steering gear is fitted, additional bending moments may be transmitted from the steering gear into the rudder stock. These additional bending moments are to be taken into account for determining the rudder stock diameter.

---e-n-d---of---N-o-t-e---

## 3.3 Analysis

### 3.3.1 General

The bending moments, shear forces and support forces for the system rudder - rudder stock are to be obtained from [3.3.2] and [3.3.3], for rudder types as shown in Fig 3 to Fig 7.

### 3.3.2 Data for the analysis

$\ell_{10}, \dots, \ell_{50}$  = Lengths, in m, of the individual girders of the system

$I_{10}, \dots, I_{50}$  = Moments of inertia of these girders, in  $\text{cm}^4$

For rudders supported by a sole piece the length  $\ell_{20}$  is the distance between lower edge of rudder body and centre of sole piece, and  $I_{20}$  is the moment of inertia of the pintle in the sole piece.

Load on rudder body, in  $\text{kN/m}$ , (general):

$$p_R = \frac{C_R}{\ell_{10} \cdot 10^3}$$

Load on semi-spade rudders, in kN/m:

$$p_{R10} = \frac{C_{R2}}{\ell_{10} \cdot 10^3}$$

$$p_{R20} = \frac{C_{R1}}{\ell_{20} \cdot 10^3}$$

$C_R, C_{R1}, C_{R2}$  = As defined in [2.1] and [2.2]

$Z$  = Spring constant, in kN/m, of support in the sole piece or rudder horn respectively: for the support in the sole piece (see Fig 3):

$$Z = \frac{6.18 I_{50}}{\ell_{50}^3}$$

for the support in the rudder horn (see Fig 4):

$$Z = \frac{1}{f_b + f_t}$$

$f_b$  = Unit displacement of rudder horn, in m/kN, due to a unit force of 1 kN acting in the centre of support

$$f_b = \frac{1.3 d^3 10^8}{3 E I_n}$$

$$f_b = 0.21 \frac{d^3}{I_n} \quad (\text{guidance value for steel})$$

$I_n$  = Moment of inertia of rudder horn, in cm<sup>4</sup>, around the  $x$ -axis at  $d/2$  (see Fig 4)

$f_t$  = Unit displacement due to a torsional moment of the amount 1, in m/kN

$$f_t = \frac{d e^2}{G J_t}$$

$$f_t = \frac{d e^2 \sum u_i / t_i}{3.14 \cdot 10^8 F_T^2} \quad \text{for steel}$$

$G$  = Modulus of rigidity, kN/m<sup>2</sup>:

$$G = 7.92 \cdot 10^7 \text{ for steel}$$

$J_t$  = Torsional moment of inertia, in m<sup>4</sup>

$F_T$  = Mean sectional area of rudder horn, in m<sup>2</sup>

$u_i$  = Breadth, in mm, of the individual plates forming the mean horn sectional area

$t_i$  = Plate thickness of individual plate having breadth  $u_i$ , in mm

$e, d$  = Distances, in m, according to Fig 4

$K_{11}, K_{22}, K_{12}$  = Rudder horn compliance constants calculated for rudder horn with 2-conjugate elastic supports (Fig 5). The 2-conjugate elastic supports are defined in terms of horizontal displacements,  $y_i$ , by the following equations:

at the lower rudder horn bearing:

$$y_1 = -K_{12} B_2 - K_{22} B_1$$

at the upper rudder horn bearing:

$$y_2 = -K_{11} B_2 - K_{12} B_1$$

where

$y_1, y_2$  = Horizontal displacements, in m, at the lower and upper rudder horn bearings, respectively

$B_1, B_2$  = Horizontal support forces, in kN, at the lower and upper rudder horn bearings, respectively

$K_{11}, K_{22}, K_{12}$  = Obtained, in m/kN, from the following formulae:

$$K_{11} = 1.3 \frac{\lambda^3}{3EJ_{1h}} + \frac{e^2 \lambda}{GJ_{th}}$$

$$K_{12} = 1.3 \left[ \frac{\lambda^3}{3EJ_{1h}} + \frac{\lambda^2(d-\lambda)}{2EJ_{1h}} \right] + \frac{e^2 \lambda}{GJ_{th}}$$

$$K_{22} = 1.3 \left[ \frac{\lambda^3}{3EJ_{1h}} + \frac{\lambda^2(d-\lambda)}{EJ_{1h}} + \frac{\lambda(d-\lambda)^2}{EJ_{1h}} + \frac{(d-\lambda)^3}{3EJ_{2h}} \right] + \frac{e^2 d}{GJ_{th}}$$

- $d$  = Height of the rudder horn, in m, defined in Fig 5. This value is measured downwards from the upper rudder horn end, at the point of curvature transition, till the mid-line of the lower rudder horn pintle
- $\lambda$  = Length, in m, as defined in Fig 5. This length is measured downwards from the upper rudder horn end, at the point of curvature transition, till the mid-line of the upper rudder horn bearing. For  $\lambda = 0$ , the above formulae converge to those of spring constant  $Z$  for a rudder horn with 1-elastic support, and assuming a hollow cross section for this part
- $e$  = Rudder-horn torsion lever, in m, as defined in Fig 5 (value taken at  $z = d/2$ )
- $J_{1h}$  = Moment of inertia of rudder horn about the  $x$  axis, in  $m^4$ , for the region above the upper rudder horn bearing. Note that  $J_{1h}$  is an average value over the length  $\lambda$  (see Fig 5)
- $J_{2h}$  = Moment of inertia of rudder horn about the  $x$  axis, in  $m^4$ , for the region between the upper and lower rudder horn bearings. Note that  $J_{2h}$  is an average value over the length  $d - \lambda$  (see Fig 5)
- $J_{th}$  = Torsional stiffness factor of the rudder horn, in  $m^4$   
For any thin wall closed section

$$J_{th} = \frac{4F_T^2}{\sum_i \frac{u_i}{t_i}}$$

- $F_T$  = Mean of areas enclosed by outer and inner boundaries of the thin walled section of rudder horn, in  $m^2$
- $u_i$  = Length, in mm, of the individual plates forming the mean horn sectional area
- $t_i$  = Thickness, in mm, of the individual plates mentioned above.

Note that the  $J_{th}$  value is taken as an average value, valid over the rudder horn height.

### 3.3.3 Moments and forces to be evaluated

- a) The bending moment  $M_R$  and the shear force  $Q_1$  in the rudder body, the bending moment  $M_b$  in the neck bearing and the support forces  $B_1, B_2, B_3$  are to be evaluated.

The so evaluated moments and forces are to be used for the stress analyses required by [3.2], [5], [9.1] and [9.2]

- b) For spade rudders (see Fig 6) the moments, in N.m, and forces, in N, may be determined by the following formulae:

$$M_b = C_R \left( \ell_{20} + \frac{\ell_{10}(2x_1 + x_2)}{3(x_1 + x_2)} \right)$$

$$B_3 = \frac{M_b}{\ell_{30}}$$

$$B_2 = C_R + B_3$$

- c) For spade rudders with rudders trunks (see Fig 7) the moments, in N.m, and forces, in N, may be determined by the following formulae:

$M_R$  is the greatest of the following values:

$$M_R = C_{R2} (\ell_{10} - CG_{2Z})$$

$$M_R = C_{R1} (CG_{1Z} - \ell_{10})$$

where:



- $C_{R1}$  = Rudder force over the rudder blade area  $A_1$
- $C_{R2}$  = Rudder force over the rudder blade area  $A_2$
- $CG_{1Z}$  = Vertical position of the centre of gravity of the rudder blade area  $A_1$
- $CG_{2Z}$  = Vertical position of the centre of gravity of the rudder blade area  $A_2$

$$M_B = C_{R2} (\ell_{10} - CG_{2Z})$$

$$B_3 = (M_B + M_{CR1}) / (\ell_{20} + \ell_{30})$$

$$B_2 = C_R + B_3$$

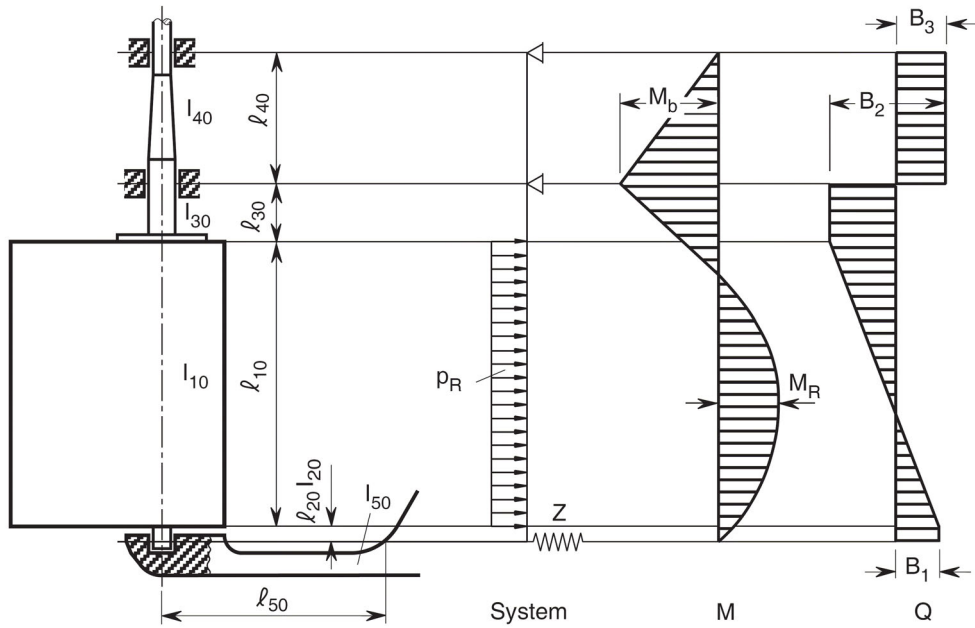

**Fig. 3**  
Rudder supported by sole piece

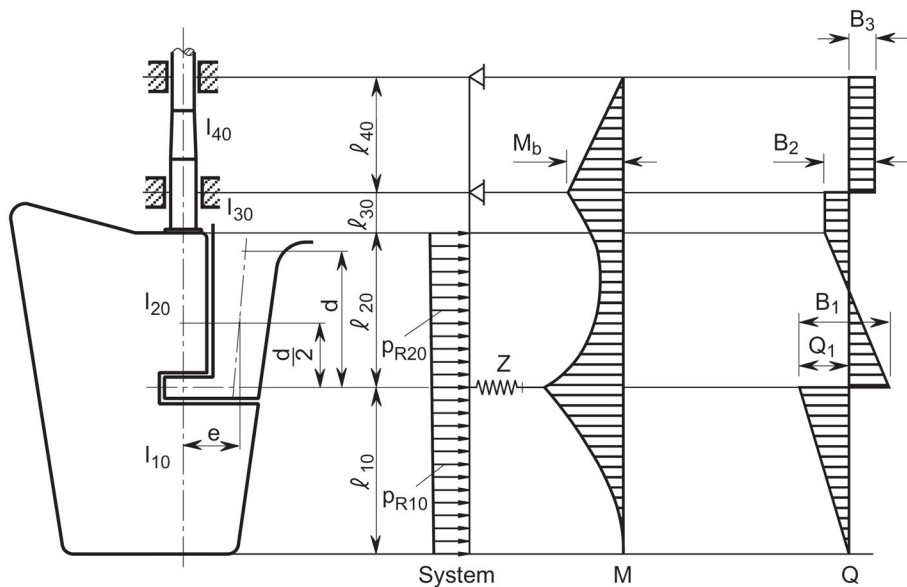

**Fig. 4**  
Semi-spade rudder (with 1-elastic support)

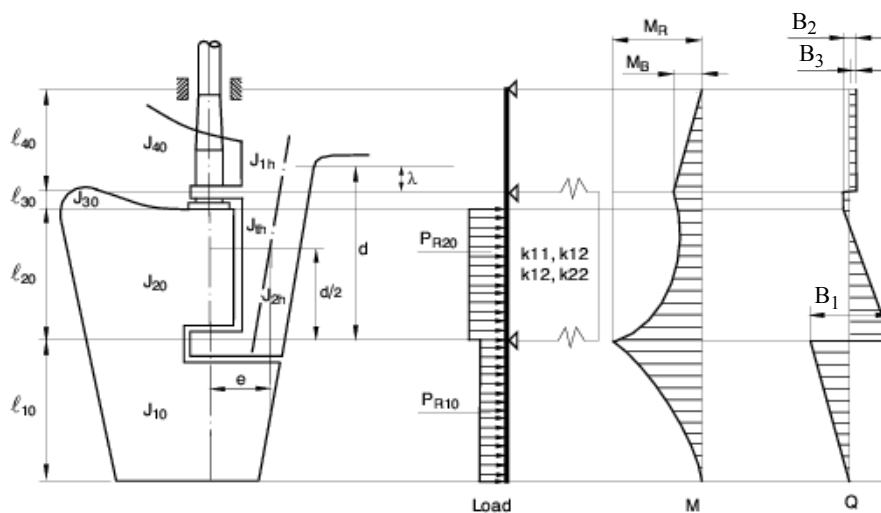

**Fig. 5**  
 Semi-spade rudder (with 2-conjugate elastic supports)

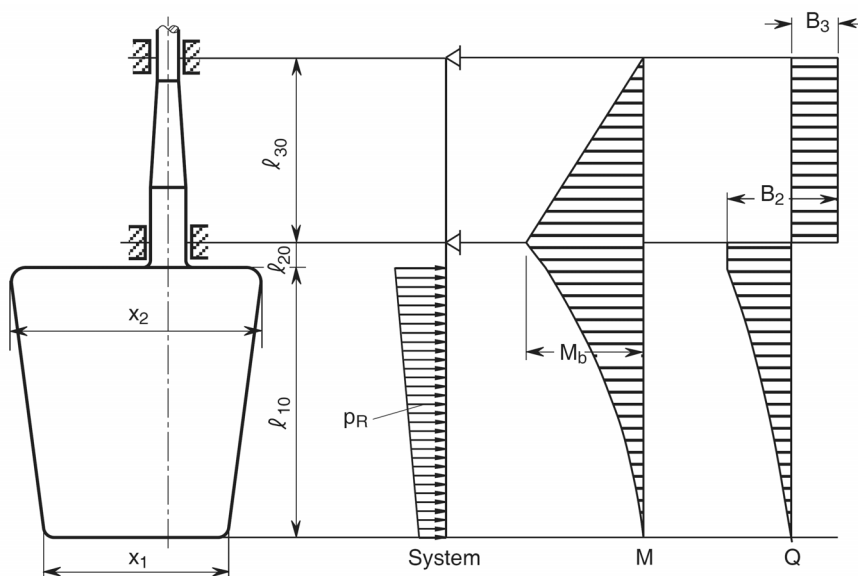

**Fig. 6**  
 Spade rudder

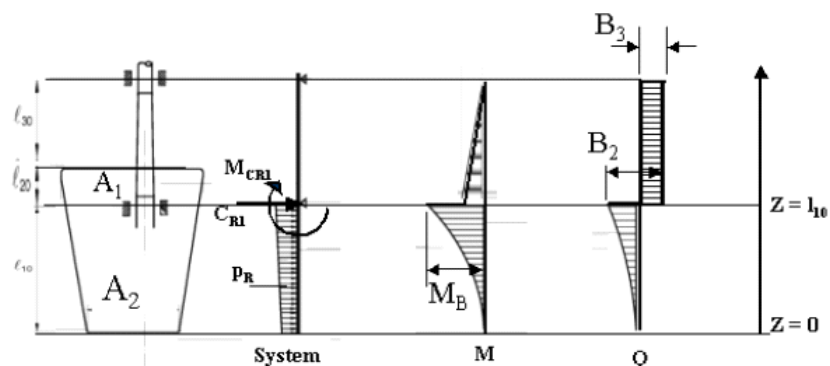

**Fig. 7**  
 Spade rudders with rudder trunks

### 3.4 Rudder trunk

#### 3.4.1

Where the rudder stock is arranged in a trunk in such a way that the trunk is stressed by forces due to rudder action, the scantlings of the trunk are to be as such that the equivalent stress due to bending and shear does not exceed  $0.35 R_{eH}$  of the material used.

#### 3.4.2

In case where the rudder stock is fitted with a rudder trunk welded in such a way the rudder trunk is loaded by the pressure induced on the rudder blade, as given in [2.1.1], the bending stress in the rudder trunk, in  $\text{N/mm}^2$ , is to be in compliance with the following formula:

$$\sigma \leq 80 / k$$

where the material factor  $k$  for the rudder trunk is not to be taken less than 0.7.

For the calculation of the bending stress, the span to be considered is the distance between the mid-height of the lower rudder stock bearing and the point where the trunk is clamped into the shell or the bottom of the skeg.

#### 3.4.3

The steel used for the rudder trunk is to be of weldable quality, with a carbon content not exceeding 0.23% on ladle analysis and a carbon equivalent CEQ not exceeding 0.41.

#### 3.4.4

The weld at the connection between the rudder trunk and the shell or the bottom of the skeg is to be full penetration.

The fillet shoulder radius  $r$ , in mm, is to be as large as practicable and to comply with the following formulae:

$$\begin{aligned} r &= 60 && \text{when } \sigma \geq 40 / k \text{ N/mm}^2 \\ r &= 0.1D_1 && \text{when } \sigma < 40 / k \text{ N/mm}^2 \end{aligned}$$

where  $D_1$  is defined in [3.2.1].

The radius may be obtained by grinding. If disk grinding is carried out, score marks are to be avoided in the direction of the weld.

The radius is to be checked with a template for accuracy. Four profiles at least are to be checked. A report is to be submitted to the Surveyor.

#### 3.4.5

Before welding is started, a detailed welding procedure specification is to be submitted to the Society covering the weld preparation, welding positions, welding parameters, welding consumables, preheating, post weld heat treatment and inspection procedures. This welding procedure is to be supported by approval tests in accordance with the applicable requirements of materials and welding sections of the rules.

The manufacturer is to maintain records of welding, subsequent heat treatment and inspections traceable to the welds. These records are to be submitted to the Surveyor.

#### 3.4.6

Non destructive tests are to be conducted at least 24 hours after completion of the welding. The welds are to be 100% magnetic particle tested and 100% ultrasonic tested. The welds are to be free from cracks, lack of fusion and incomplete penetration. The non destructive tests reports are to be handed over to the Surveyor.

#### 3.4.7

Rudder trunks in materials other than steel are to be specially considered by the Society.

#### 3.4.8

The thickness of the shell or of the bottom plate is to be compatible with the trunk thickness.

## 4 Rudder couplings

### 4.1 General

#### 4.1.1

The couplings are to be designed in such a way as to enable them to transmit the full torque of the rudder stock.

#### 4.1.2

The distance of the bolt axis from the edges of the flange is not to be less than 1.2 times the diameter of the bolt. In horizontal couplings, at least 2 bolts are to be arranged forward of the stock axis.

#### 4.1.3

The coupling bolts are to be fitted bolts. The bolts and nuts are to be effectively secured against loosening.

#### 4.1.4

For spade rudders, horizontal couplings according to [4.2] are permitted only where the required thickness of the coupling flanges  $t_f$  is less than 50 mm, otherwise cone coupling according to [4.4] or [4.5], as applicable, is to be applied. For spade rudders of the high lift type, only cone coupling according to [4.4] or [4.5], as applicable, is permitted.

### 4.2 Horizontal couplings

#### 4.2.1

The diameter of coupling bolts, in mm, is not to be less than:

$$d_b = 0.62 \sqrt{\frac{D^3 k_b}{k_r n e}}$$

where:

$D$  = Rudder stock diameter according to [6], in mm

$n$  = Total number of bolts, which is not to be less than 6

$e$  = Mean distance of the bolt axes from the centre of bolt system, in mm

$k_r$  = Material factor for the rudder stock as defined in [1.4.2]

$k_b$  = Material factor for the bolts, obtained according to [1.4.2].

#### 4.2.2

The thickness of the coupling flanges, in mm, is not to be less than determined by the following formulae:

$$t_f = 0.62 \sqrt{\frac{D^3 k_f}{k_r n e}}, \text{ without being less than } 0.9d_b.$$

where:

$k_f$  = Material factor for the coupling flanges, obtained according to [1.4.2]

The thickness of the coupling flanges clear of the bolt holes is not to be less than  $0.65t_f$ .

The width of material outside the bolt holes is not to be less than  $0.67d_b$ .

#### 4.2.3

The coupling flanges are to be equipped with a fitted key according to DIN 6885 or equivalent standard for relieving the bolts.

The fitted key may be dispensed with if the diameter of the bolts is increased by 10%.

#### 4.2.4

Horizontal coupling flanges are to be either forged together with the rudder stock or welded to the rudder stock, according to [10.1.3].

#### 4.2.5

For the connection of the coupling flanges with the rudder body, see also [10].

### 4.3 Vertical couplings

#### 4.3.1

The diameter of the coupling bolts, in mm, is not to be less than:

$$d_b = \frac{0.81D}{\sqrt{n}} \sqrt{k_b}$$

where:

$D$ ,  $k_b$ ,  $k_r$ ,  $n$  are defined in [4.2.1], where  $n$  is not to be less than 8.

#### 4.3.2

The first moment of area of the bolts, in  $\text{cm}^3$ , about the centre of the coupling is not to be less than:  $S = 0.00043D^3$ .

#### 4.3.3

The thickness of the coupling flanges, in mm, is not to be less than

$$t_f = d_b$$

The width of material outside the bolt holes is not to be less than  $0.67d_b$ .

### 4.4 Cone couplings with key

#### 4.4.1

Cone couplings should have a taper  $c$  on diameter of 1:8 to 1:12, where  $c = (d_0 - d_u)/\ell$  (see Fig 8).

The cone shapes are to fit very exact. The nut is to be carefully secured, e.g. by a securing plate as shown in Fig 8.

#### 4.4.2

The coupling length  $\ell$  is to be, in general, not less than  $1.5 d_0$ .

#### 4.4.3

For couplings between stock and rudder a key is to be provided, the shear area of which, in  $\text{cm}^2$ , is not to be less than:

$$a_s = \frac{17.55Q_F}{d_k R_{eH1}}$$

where:

- $Q_F$  = Design yield moment of rudder stock, in Nm according to [6]
- $d_k$  = Diameter of the conical part of the rudder stock, in mm, at the key
- $R_{eH1}$  = Minimum yield stress of the key material, in  $\text{N/mm}^2$

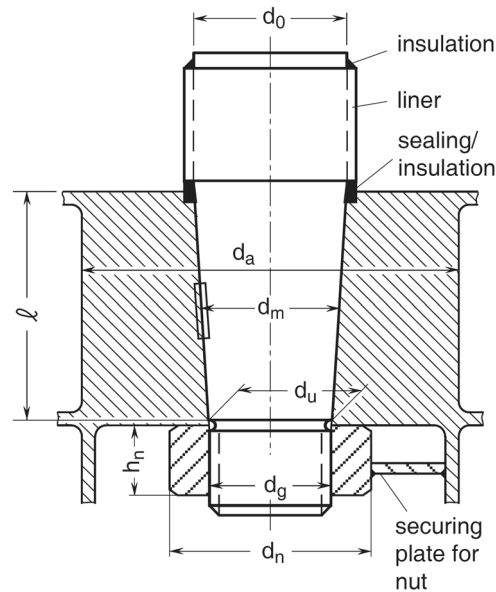

**Fig. 8**  
**Cone coupling with key**

#### 4.4.4

The effective surface area, in cm<sup>2</sup>, of the key (without rounded edges) between key and rudder stock or cone coupling is not to be less than:

$$a_k = \frac{5Q_F}{d_k R_{eH2}}$$

where:

$R_{eH2}$  = Minimum yield stress of the key, stock or coupling material, in N/mm<sup>2</sup>, whichever is less.

#### 4.4.5

The dimensions of the slugging nut are to be as follows (see Fig 8):

- height:  $h_n = 0.6d_g$
- outer diameter, the greater value of:  $d_n = 1.2 d_u$  or  $d_n = 1.5 d_g$
- external thread diameter:  $d_g = 0.65 d_0$

#### 4.4.6

It is to be proved that 50% of the design yield moment will be solely transmitted by friction in the cone couplings. This can be done by calculating the required push-up pressure and push-up length according to [4.5.3] for a torsional moment  $Q'_F = 0.5Q_F$ .

### 4.5 Cone couplings with special arrangements for mounting and dismounting the couplings

#### 4.5.1

Where the stock diameter exceeds 200 mm, the press fit is recommended to be effected by a hydraulic pressure connection. In such cases the cone is to be more slender,  $c \approx 1:12$  to  $\approx 1:20$ .

#### 4.5.2

In case of hydraulic pressure connections the nut is to be effectively secured against the rudder stock or the pintle. A securing plate for securing the nut against the rudder body is not to be provided (see Fig 9).

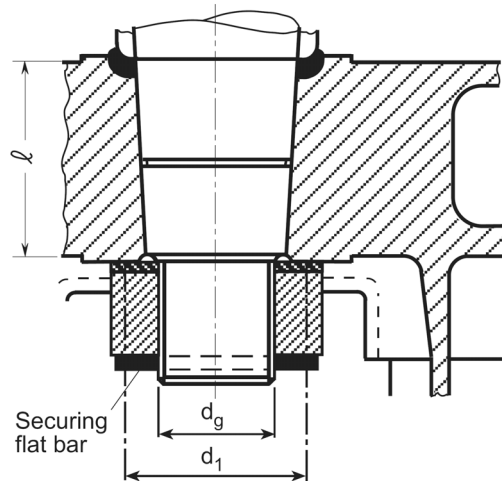

**Fig. 9**  
**Cone coupling without key**

**Note:**

A securing flat bar will be regarded as an effective securing device of the nut, if its shear area, in mm<sup>2</sup>, is not less than:

$$A_s = \frac{P_s \cdot \sqrt{3}}{R_{eH}}$$

where:

$P_s$  = Shear force, in N, as follows:

$$P_s = \frac{P_e}{2} \mu_1 \left( \frac{d_1}{d_g} - 0.6 \right)$$

$P_e$  = Push-up force according to [4.5.3], in N

$\mu_1$  = Frictional coefficient between nut and rudder body, normally  $\mu_1 = 0.3$

$d_1$  = Mean diameter of the frictional area between nut and rudder body

$d_g$  = Thread diameter of the nut

$R_{eH}$  = Minimum yield stress, in N/mm, of the securing flat bar material.

---e-n-d---of---N-o-t-e---

### 4.5.3 Push-up pressure and push-up length

For the safe transmission of the torsional moment by the coupling between rudder stock and rudder body the push-up length and the push-up pressure are to be determined according to [4.5.4] and [4.5.5].

### 4.5.4 Push-up pressure

The push-up pressure is not to be less than the greater of the two following values:

$$p_{req1} = \frac{2Q_F}{d_m^2 \ell \pi \mu_0} 10^3$$

$$p_{req2} = \frac{6 \cdot M_b}{\ell^2 d_m} 10^3$$

where:

$Q_F$  = Design yield moment of rudder stock according to [6], in N.m

$d_m$  = Mean cone diameter, in mm

$\ell$  = Cone length, in mm

$\mu_0$  = Frictional coefficient, equal to about 0.15

$M_b$  = Bending moment in the cone coupling (e.g. in case of spade rudders), in N.m

It has to be proved that the push-up pressure does not exceed the permissible surface pressure in the cone. The

permissible surface pressure is to be determined by the following formula:

$$p_{perm} = \frac{0.8R_{eH}(1-\alpha^2)}{\sqrt{3+\alpha^4}}$$

where:

$R_{eH}$  = Minimum yield stress, in N/mm<sup>2</sup>, of the material of the gudgeon

$$\alpha = \frac{d_m}{d_a}$$

$d_m$  = Diameter, in mm, as defined in Fig 8

$d_a$  = Outer diameter of the gudgeon (see Fig 8), in mm, to be not less than  $1.5d_m$ .

#### 4.5.5 Push-up length

The push-up length, in mm, is not to be less than:

$$\Delta\ell_1 = \frac{P_{req}d_m}{E\left(\frac{1-\alpha^2}{2}\right)c} + \frac{0.8R_{tm}}{c}$$

where:

$R_{tm}$  = Mean roughness, in mm, taken equal to about 0.01

$c$  = Taper on diameter according to [4.5.1]

The push-up length, in mm, is, however, not to be taken greater than:

$$\Delta\ell_2 = \frac{1.6R_{eH}d_m}{Ec\sqrt{3+\alpha^4}} + \frac{0.8R_{tm}}{c}$$

#### Note:

In case of hydraulic pressure connections the required push-up force  $P_e$  for the cone, in N, may be determined by the following formula:

$$P_e = p_{req} d_m \pi \ell \left( \frac{c}{2} + 0.02 \right)$$

The value 0.02 is a reference for the friction coefficient using oil pressure. It varies and depends on the mechanical treatment and roughness of the details to be fixed.

Where due to the fitting procedure a partial push-up effect caused by the rudder weight is given, this may be taken into account when fixing the required push-up length, subject to approval by the Society.

---e-n-d---of---N-o-t-e---

#### 4.5.6 Push-up pressure for pintle bearings

The required push-up pressure for pintle bearings, in N/mm<sup>2</sup>, is to be determined by the following formula:

$$p_{req} = 0.4 \frac{B_1 d_0}{d_m^2 \ell}$$

where:

$B_1$  = Supporting force in the pintle bearing, in N (see Fig 4)

$d_{m,\ell}$  = As defined in [4.5.3]

$d_0$  = Pintle diameter, in mm, according to Fig 8.

## 5 Rudder body, rudder bearings

### 5.1 Strength of rudder body

#### 5.1.1

The rudder body is to be stiffened by horizontal and vertical webs in such a manner that the rudder body will be effective as a beam. The rudder should be additionally stiffened at the aft edge.



### 5.1.2

The strength of the rudder body is to be proved by direct calculation according to [3.3]

### 5.1.3

For rudder bodies without cut-outs the permissible stress are limited to:

— bending stress, in N/mm<sup>2</sup>, due to  $M_R$  defined in [3.3.3]:

$$\sigma_b = 110$$

— shear stress, in N/mm<sup>2</sup>, due to  $Q_1$  defined in [3.3.3]:

$$\tau_t = 50$$

— equivalent stress, in N/mm<sup>2</sup>, due to bending and shear:

$$\sigma_v = \sqrt{\sigma_b^2 + 3\tau^2} = 120$$

In case of openings in the rudder plating for access to cone coupling or pintle nut the permissible stresses according to [5.1.4] apply. Smaller permissible stress values may be required if the corner radii are less than  $0.15h_o$ , where  $h_o$  is the height of opening.

### 5.1.4

In rudder bodies with cut-outs (semi-spade rudders) the following stress values are not to be exceeded:

— bending stress, N/mm<sup>2</sup>, due to  $M_R$ :  $\sigma_b = 90$

— shear stress, N/mm<sup>2</sup>, due to  $Q_1$ :  $\tau = 50$

— torsional stress, N/mm<sup>2</sup>, due to  $M_t$ :  $\tau_t = 50$

— equivalent stress, in N/mm<sup>2</sup>, due to bending and shear and equivalent stress due to bending and torsion:

$$\sigma_{v1} = \sqrt{\sigma_b^2 + 3\tau^2} = 120$$

$$\sigma_{v2} = \sqrt{\sigma_b^2 + 3\tau_t^2} = 100$$

where:

$$M_R = C_{R2}f_1 + B_1 \frac{f_2}{2}, \text{ in N.m}$$

$$Q_1 = C_{R2}, \text{ in N}$$

$f_1, f_2$  = As defined in Fig 10

$\tau_t$  = Torsional stress, in N/mm<sup>2</sup>, taken equal to:

$$\tau_t = \frac{M_t}{2 \ell h t}$$

$$M_t = C_{R2} e, \text{ in N.m}$$

$C_{R2}$  = Partial rudder force, in N, of the partial rudder area  $A_2$  below the cross section under consideration

$e$  = Lever for torsional moment, in m (horizontal distance between the centre of pressure of area  $A_2$  and the centre line a-a of the effective cross sectional area under consideration, see Fig 10. The centre of pressure is to be assumed at  $0.33c_2$  aft of the forward edge of area  $A_2$ , where  $c_2$  is the mean breadth of area  $A_2$ ).

$h, \ell, t$  = Dimensions, in cm, as defined in Fig 10.

The distance  $\ell$  between the vertical webs should not exceed  $1.2h$ .

The radii in the rudder plating are not to be less than 4 to 5 times the plate thickness, but in no case less than 50 mm.

**Note:**

It is recommended to keep the natural frequency of the fully immersed rudder and of local structural components at least 10 % above the exciting frequency of the propeller (number of revolutions  $\times$  number of blades) or if relevant above higher order.

---e-n-d---of---N-o-t-e---

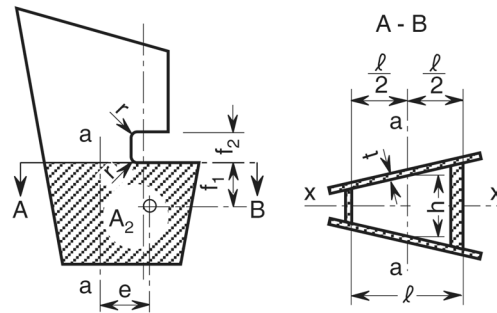

**Fig. 10**  
**Geometry of rudder**

## 5.2 Rudder plating

### 5.2.1

The thickness of the rudder plating, in mm, is to be determined according to the following formula:

$$t_p = 1.74a\beta\sqrt{p_R k} + 2.5$$

where:

$$p_R = 10T + \frac{C_R}{10^3 A}, \text{ in kN/m}^2$$

$a$  = Smaller unsupported width of a plate panel, in m.

$$\beta = \sqrt{1.1 - 0.5\left(\frac{a}{b}\right)^2} \quad \text{max, 1.00, if } \frac{b}{a} \geq 2.5$$

$b$  = greatest unsupported width of a plate panel, in m.

However, the thickness is to be not less than the thickness of the shell plating at aft part according to Ch 9, Sec 2.

Regarding dimensions and welding, [10.1.1] is to be comply with.

### 5.2.2

For connecting the side plating of the rudder to the webs tenon welding is not to be used. Where application of fillet welding is not practicable, the side plating is to be connected by means of slot welding to flat bars which are welded to the webs.

### 5.2.3

The thickness of the webs, in mm, is not to be less than 70 % of the thickness of the rudder plating according to [5.2.1], but not less than:

$$t_{\min} = 8\sqrt{k}$$

Webs exposed to seawater are to be dimensioned according to [5.2.1].

## 5.3 Connections of rudder blade structure with solid parts in forged or cast steel

### 5.3.1 General

Solid parts in forged or cast steel which ensure the housing of the rudder stock or of the pintle are in general to be connected to the rudder structure by means of two horizontal web plates and two vertical web plates.

### 5.3.2 Minimum section modulus of the connection with the rudder stock housing

The section modulus of the cross-section of the structure of the rudder blade which is connected with the solid part where the rudder stock is housed, which is made by vertical web plates and rudder plating, is to be not less than that obtained, in  $\text{cm}^3$ , from the following formula:

$$w_S = c_S d_1^3 \left( \frac{H_E - H_X}{H_E} \right)^2 \frac{k}{k_1} 10^{-4}$$

where:

$c_S$  = Coefficient, to be taken equal to:

$c_S = 1.0$  if there is no opening in the rudder plating or if such openings are closed by a full penetration welded plate

$c_S = 1.5$  if there is an opening in the considered cross-section of the rudder

$D_1$  = Rudder stock diameter, in mm, defined in [3.2.1]

$H_E$  = Vertical distance, in m, between the lower edge of the rudder blade and the upper edge of the solid part

$H_X$  = Vertical distance, in m, between the considered cross-section and the upper edge of the solid part

$k, k_1$  = Material factors, defined for the rudder blade plating and the rudder stock, respectively.

### 5.3.3 Calculation of the actual section modulus of the connection with the rudder stock housing

The actual section modulus of the cross-section of the structure of the rudder blade which is connected with the solid part where the rudder stock is housed is to be calculated with respect to the symmetrical axis of the rudder.

The breadth of the rudder plating to be considered for the calculation of this actual section modulus is to be not greater than that obtained, in m, from the following formula:

$$b = s_V + 2 \frac{H_X}{m}$$

where:

$s_V$  = Spacing, in m, between the two vertical webs (see Fig 11)

$H_X$  = Distance defined in [5.3.2]

$m$  = Coefficient to be taken, in general, equal to 3.

Where openings for access to the rudder stock nut are not closed by a full penetration welded plate, they are to be deducted (see Fig 11).

### 5.3.4 Thickness of horizontal web plates

In the vicinity of the solid parts, the thickness of the horizontal web plates, as well as that of the rudder blade plating between these webs, is to be not less than the greater of the values obtained, in mm, from the following formulae:

$$t_H = 1.2 t_P$$

$$t_H = 0.045 \frac{d_S^2}{s_H}$$

where:

$t_P$  = Defined in [5.2.1]

$d_S$  = Diameter, in mm, to be taken equal to:

$d_S = D_1$  for the solid part connected to the rudder stock

$d_S = d_a$  for the solid part connected to the pintle

$D_1$  = Rudder stock diameter, in mm, defined in [3.2.1]

$d_a$  = Pintle diameter, in mm, defined in [5.5.1]

$s_H$  = Spacing, in mm, between the two horizontal web plates.

Different thickness may be accepted when justified on the basis of direct calculations submitted to the Society for approval.

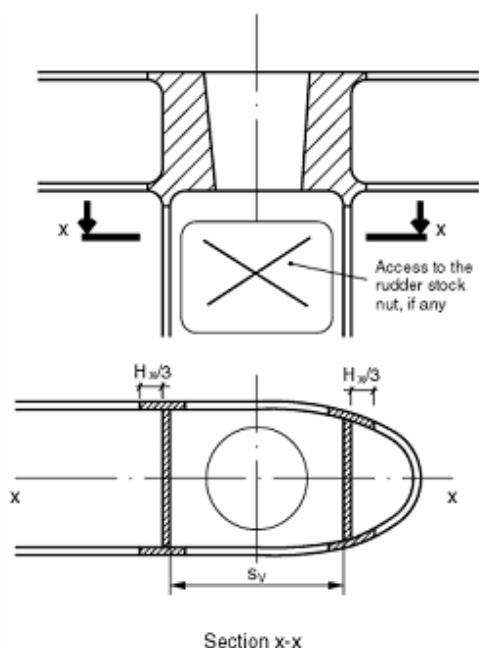

**Fig. 11**  
**Cross-section of the connection between rudder blade structure and rudder stock housing**

### 5.3.5 Thickness of side plating and vertical web plates welded to the solid part

The thickness of the vertical web plates welded to the solid part where the rudder stock is housed as well as the thickness of the rudder side plating under this solid part is to be not less than the values obtained, in mm, from Table 2.

Type of rudder	Thickness of vertical web plates, in mm		Thickness of rudder plating, in mm	
	Rudder blade without opening	At opening boundary	Rudder blade without opening	Area with opening
Rudder supported by sole piece (Fig 3)	$1.2t_P$	$1.6t_P$	$1.2t_P$	$1.4t_P$
Semi-spade and spade rudders (Fig 4 to Fig 7)	$1.4t_P$	$2.0t_P$	$1.3t_P$	$1.6t_P$

$t_P$  : Defined in [5.2.1]

### 5.3.6 Solid part protrusions

The solid parts are to be provided with protrusions. Vertical and horizontal web plates of the rudder are to be butt welded to these protrusions.

These protrusions are not required when the web plate thickness is less than:

- 10 mm for web plates welded to the solid part on which the lower pintle of a semi-spade rudder is housed and for vertical web plates welded to the solid part of the rudder stock coupling of spade rudders
- 20 mm for the other web plates.

### 5.3.7

If the torque is transmitted by a prolonged shaft extended into the rudder, the latter must have the diameter  $D_t$  or  $D_1$ , whichever is greater, at the upper 10 % of the intersection length. Downwards it may be tapered to  $0.6D_b$  in spade rudders to 0.4 times the strengthened diameter, if sufficient support is provided for.

## 5.4 Rudder bearings

### 5.4.1

In way of bearings liners and bushes are to be fitted.

Their minimum thickness is equal to:

- $t_{min} = 8$  mm for metallic materials and synthetic material
- $t_{min} = 22$  mm for lignum material

Where in case of small ships bushes are not fitted, the rudder stock is to be suitably increased in diameter in way of bearings enabling the stock to be re-machined later.

#### 5.4.2

An adequate lubrication is to be provided.

#### 5.4.3

The bearing forces result from the direct calculation mentioned in [3.3]. As a first approximation the bearing force may be determined without taking account of the elastic supports. This can be done as follows:

- normal rudder with two supports:  
The rudder force  $C_R$  is to be distributed to the supports according to their vertical distances from the centre of gravity of the rudder area.
- semi-spade rudders:  
support force in the rudder horn, in N:

$$B_1 = C_R \frac{b}{c}$$

support force in the neck bearing, in N:

$$B_2 = C_R - B_1$$

For  $b$  and  $c$  see Fig 14.

#### 5.4.4

The projected bearing surface  $A_b$  (“bearing height” × “external diameter of liner”), in mm<sup>2</sup>, is not to be less than

$$A_b = \frac{B}{q}$$

where:

- $B$  = Support force, in N
- $q$  = Permissible surface pressure according to Table 3.

#### 5.4.5

Stainless and wear resistant steels, bronze and hot-pressed bronze-graphit materials have a considerable difference in potential to non-alloyed steel. Respective preventive measures are required.

#### 5.4.6

The bearing height is to be equal to the bearing diameter, however, is not to exceed 1.2 times the bearing diameter. Where the bearing depth is less than the bearing diameter, higher specific surface pressures may be allowed.

<b>Table 3 Surface pressure q of bearing materials</b>	
<i>Bearing material</i>	<i>q, in N/mm<sup>2</sup></i>
Lignum vitae	2.5
White metal, oil lubricated	4.5
Synthetic material <sup>(1)</sup>	5.5
Steel <sup>(2)</sup> , bronze and hot-pressed bronze-graphite materials	7.0
<sup>(1)</sup> Synthetic materials to be of approved type. Surface pressures exceeding 5.5 N/mm <sup>2</sup> may be accepted in accordance with bearing manufacturer's specification and tests, but in no case more than 10 N/mm <sup>2</sup> .	
<sup>(2)</sup> Stainless and wear resistant steel in an approved combination with stock liner. Higher surface pressures than 7 N/mm <sup>2</sup> may be accepted if verified by tests.	

The wall thickness of pintle bearings in sole piece and rudder horn is to be approximately equal to one fourth of the pintle diameter.

## 5.5 Pintles

### 5.5.1

Pintles are to have scantlings complying with the conditions given in [4.4] and [4.6]. The pintle diameter, in mm, is not to be less than:

$$d_a = 0.35\sqrt{B_1 k_r}$$

where:

$B_1$  = Support force, in N

$k_r$  = Material factor defined in [1.4.2].

### 5.5.2

The thickness of any liner or bush, in mm, is neither to be less than:

$$t = 0.01\sqrt{B_1}$$

nor than the minimum thickness defined in [5.4.1].

### 5.5.3

Where pintles are of conical shape, the taper on diameter is to comply with the following:

- 1:8 to 1:12, if keyed by slugging nut
- 1:12 to 1:20, if mounted with oil injection and hydraulic nut

### 5.5.4

The pintles are to be arranged in such a manner as to prevent unintentional loosening and falling out.

For nuts and threads the requirements of [4.4.5] and [4.5.2] apply accordingly.

## 5.6 Criteria for bearing clearances

### 5.6.1

For metallic bearing material the bearing clearance, in mm, is to be not less:

$$\frac{d_b}{1000} + 1.0$$

where:

$d_b$  = Inner diameter of bush, in mm.

### 5.6.2

If non-metallic bearing material is applied, the bearing clearance is to be specially determined considering the material's swelling and thermal expansion properties.

### 5.6.3

The clearance is not to be taken less than 1.5 mm on diameter. In case of self lubricating bushes going down below this value can be agreed to on the basis of the manufacturer's specification.

## 6 Design yield moment of rudder stock

### 6.1 General

#### 6.1.1

The design yield moment of the rudder stock is to be determined by the following formula:

$$Q_F = 0.02664 \frac{D_t^3}{k_r}$$

$D_t$  = Stock diameter, in mm, according to [3.1].

Where the actual diameter  $D_{ta}$  is greater than the calculated diameter  $D_t$ , the diameter  $D_{ta}$  is to be used. However,  $D_{ta}$  applied to the above formula need not be taken greater than 1.145  $D_t$ .

## 7 Stopper, locking device

### 7.1 Stopper

#### 7.1.1

The motions of quadrants or tillers are to be limited on either side by stoppers. The stoppers and their foundations connected to the ship's hull are to be of strong construction so that the yield point of the applied materials is not exceeded at the design yield moment of the rudder stock.

### 7.2 Locking device

#### 7.2.1

Each steering gear is to be provided with a locking device in order to keep the rudder fixed at any position. This device as well as the foundation in the ship's hull are to be of strong construction so that the yield point of the applied materials is not exceeded at the design yield moment of the rudder stock as specified in [6]. Where the ship's speed exceeds 12 knots, the design yield moment need only be calculated for a stock diameter based on a speed  $V_0 = 12$  knots.

### 7.3

#### 7.3.1

Regarding stopper and locking device see also the applicable requirements of the Society's Rules for Machinery Installations.

## 8 Propeller nozzles

### 8.1 General

#### 8.1.1

The following requirements are applicable to propeller nozzles having an inner diameter of up to 5 m. Nozzles with larger diameters will be specially considered.

#### 8.1.2

Special attention is to be given to the support of fixed nozzles at the hull structure.

### 8.2 Design pressure

#### 8.2.1

The design pressure for propeller nozzles, in  $\text{kN/m}^2$ , is to be determined by the following formula:

$$P_d = c P_{d0}$$

$$p_{d0} = \varepsilon \frac{N}{A_p}$$

where:

$N$  = Maximum shaft power, in kW

$A_p$  = Propeller disc area, in  $m^2$ , taken equal to:

$$A_p = D^2 \frac{\pi}{4}$$

$D$  = Propeller diameter, in m

$\varepsilon$  = Factor obtained from the following formula:

$$\varepsilon = 0.21 - 2 \cdot 10^{-4} \frac{N}{A_p}$$

without being taken less than 0.1

$c$  = Coefficient taken equal to (see Fig 12):

$c = 1.0$  in zone 2 (propeller zone)

$c = 0.5$  in zones 1 and 3

$c = 0.35$  in zone 4.

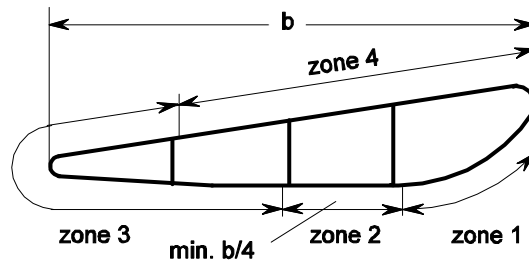

Fig. 12  
Zones of propeller nozzle

## 8.3 Plate thickness

### 8.3.1

The thickness of the nozzle shell plating, in mm, is not to be less than:

$$t = t_0 + t_k, \text{ without being taken less than } 7.5$$

where:

$t_0$  = Thickness, in mm, obtained from the following formula:

$$t_0 = 5a\sqrt{p_d}$$

$a$  = Spacing of ring stiffeners, in m

$t_k$  = Corrosion allowance, in mm, taken equal to:

$$t_k = 1.5 \quad \text{if } t_0 \leq 10$$

$$t_k = \min \left[ 0.1 \left( \frac{t_0}{\sqrt{k}} + 0.5 \right), 3.0 \right] \quad \text{if } t_0 > 10$$

### 8.3.2

The web thickness of the internal stiffening rings is not to be less than the nozzle plating for zone 3, however, in no case be less than 7.5 mm.



## 8.4 Section modulus

### 8.4.1

The section modulus of the cross section shown in Fig 12 around its neutral axis, in  $\text{cm}^3$ , is not to be less than:

$$w = n d^2 b V_0^2$$

where:

$d$  = Inner diameter of nozzle, in m

$b$  = Length of nozzle, in m

$n$  = Coefficient taken equal to:

$n = 1.0$  , for rudder nozzles

$n = 0.7$  , for fixed nozzles.

## 8.5 Welding

### 8.5.1

The inner and outer nozzle shell plating is to be welded to the internal stiffening rings as far as practicable by double continuous welds. Plug welding is only permissible for the outer nozzle plating.

## 9 Rudder horn and sole piece scantlings

### 9.1 Sole piece

#### 9.1.1

The section modulus of the sole piece related to the  $z$ -axis, in  $\text{cm}^3$ , is not to be less than:

$$W_z = \frac{B_1 x k}{80}$$

where:

$B_1$  = As defined in [3.3]. For rudders with two supports the support force is approximately  $B_1 = C_R/2$ , when the elasticity of the sole piece is ignored.

$x$  = Distance, in m, of the respective cross section from the rudder axis, with:

$$x_{\min} = 0.5\ell_{50}$$

$$x_{\max} = \ell_{50}$$

$\ell_{50}$  = As defined in Fig 13 and [3.3.2].

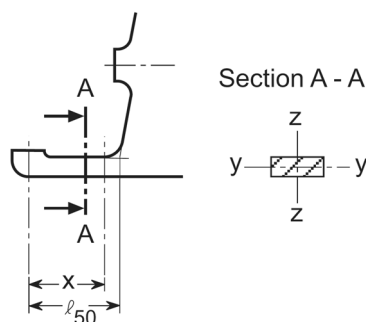

**Fig. 13**  
Sole piece

#### 9.1.2

The section modulus related to the  $y$ -axis is not to be less than:

— where no rudder post or rudder axle is fitted

$$W_y = \frac{W_z}{2}$$

— where a rudder post or rudder axle is fitted

$$W_y = \frac{W_z}{3}$$

### 9.1.3

The sectional area, in mm<sup>2</sup>, at the location  $x = \ell_{50}$  is not to be less than:

$$A_s = \frac{B_1}{48} k$$

### 9.1.4

The equivalent stress taking into account bending and shear stresses, in N/mm<sup>2</sup>, at any location within the length  $\ell_{50}$  is not to exceed:

$$\sigma_v = \sqrt{\sigma_b^2 + 3\tau^2} = \frac{115}{k}$$

where:

$$\sigma_b = \frac{B_1 x}{W_z}$$
$$\tau = \frac{B_1}{A_s}$$

## 9.2 Rudder horn of semi spade rudders (case of 1-elastic support)

### 9.2.1

The distribution of the bending moment, in N.m, shear force, in N, and torsional moment, in N.m, is to be determined according to the following formulae:

— bending moment:

$$M_b = B_1 z$$
$$M_{b \max} = B_1 d$$

— shear force:

$$Q = B_1$$

— torsional moment:

$$M_T = B_1 e_{(z)}$$

For determining preliminary scantlings the flexibility of the rudder horn may be ignored and the supporting force  $B_1$ , in N, be calculated according to the following formula:

$$B_1 = C_R \frac{b}{c}$$

where  $b$ ,  $c$ ,  $d$ ,  $e_{(z)}$  and  $z$  are defined in Fig 14 and Fig 15.

$b$  results from the position of the centre of gravity of the rudder area.

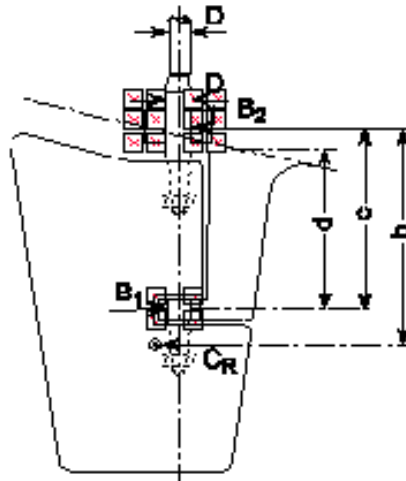

**Fig. 14**  
**Dimensions of rudder horn**

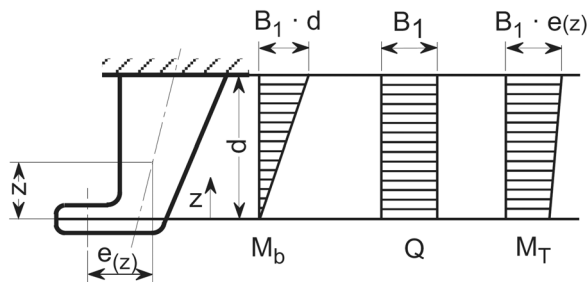

**Fig. 15**  
**Rudder horn loads**

### 9.2.2

The section modulus of the rudder horn in transverse direction related to the horizontal  $x$ -axis is at any location  $z$ , in  $\text{cm}^3$ , not to be less than:

$$W_x = \frac{M_b k}{67}$$

### 9.2.3

At no cross section of the rudder horn the shear stress, in  $\text{N/mm}^2$ , due to the shear force  $Q$  is to exceed the value:

$$\tau = \frac{48}{k}$$

The shear stress, in  $\text{N/mm}^2$ , is to be determined by the following formula:

$$\tau = \frac{B_1}{A_h}$$

where:

$A_h$  = Effective shear area of the rudder horn, in  $\text{mm}^2$ , in  $y$ -direction

### 9.2.4

The equivalent stress, in  $\text{N/mm}^2$ , at any location  $z$  of the rudder horn is not to exceed the following value:

$$\sigma_v = \sqrt{\sigma_b^2 + 3(\tau^2 + \tau_T^2)} = \frac{120}{k}$$

where:

$$\sigma_b = \frac{M_b}{W_x}$$

$$\tau_T = \frac{M_T}{2A_T t_h} 10^3$$

$A_T$  = Sectional area, in mm<sup>2</sup>, enclosed by the rudder horn at the location considered

$t_h$  = Thickness of the rudder horn plating, in mm.

### 9.2.5

When determining the thickness of the rudder horn plating the provisions of [5.2] to [5.4] are to be complied with. The thickness, in mm, is, however, not to be less than .

$$2.4\sqrt{LK}$$

### 9.2.6

The rudder horn plating is to be effectively connected to the aft ship structure, e.g. by connecting the plating to longitudinal girders, in order to achieve a proper transmission of forces, see Fig 16.

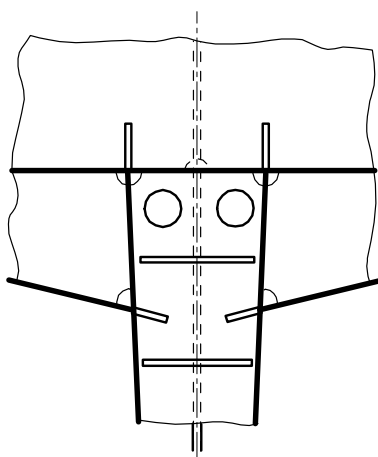

**Fig. 16**  
**Connection of rudder horn to aft ship structure**

### 9.2.7

Transverse webs of the rudder horn are to be led into the hull up to the next deck in a sufficient number and must be of adequate thickness.

### 9.2.8

Strengthened plate floors are to be fitted in line with the transverse webs in order to achieve a sufficient connection with the hull. The thickness of these plate floors is to be increased by 50% above the bottom thickness determined according to Ch 6, Sec 1 or Ch 9, Sec 2.

### 9.2.9

The centre line bulkhead (wash-bulkhead) in the after peak is to be connected to the rudder horn.

### 9.2.10

Where the transition between rudder horn and shell is curved, about 50% of the required total section modulus of the rudder horn is to be formed by the webs in a section A - A located in the centre of the transition zone, i.e.  $0.7r$  above the beginning of the transition zone (See Fig. 17).

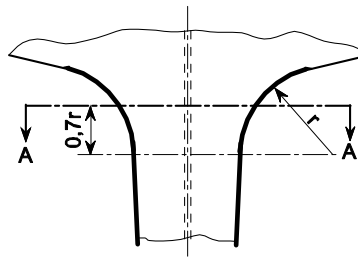

Fig. 17  
Transition between rudder horn and shell

### 9.3 Rudder horn of semi spade rudders (case of 2-conjugate elastic supports)

#### 9.3.1 Bending moment

The bending moment acting on the generic section of the rudder horn is to be obtained, in N.m, from the following formulae:

— between the lower and upper supports provided by the rudder horn:

$$M_H = F_{A1} z$$

— above the rudder horn upper-support:

$$M_H = F_{A1} z + F_{A2} (z - d_{lu})$$

where:

$F_{A1}$  = Support force at the rudder horn lower-support, in N, to be obtained according to Fig 5, and taken equal to  $B_1$

$F_{A2}$  = Support force at the rudder horn upper-support, in N, to be obtained according to Fig 5, and taken equal to  $B_2$

$z$  = Distance, in m, defined in Fig 19, to be taken less than the distance  $d$ , in m, defined in the same figure

$d_{lu}$  = Distance, in m, between the rudder-horn lower and upper bearings (according to Fig 18,  $d_{lu} = d - \lambda$ ).

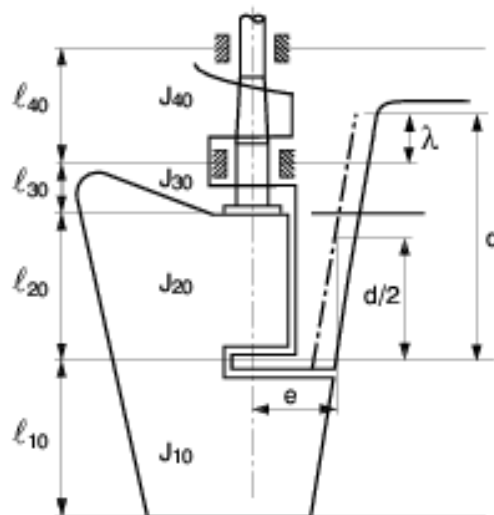

Fig. 18  
Geometrical parameters for the calculation of the bending moment in rudder horn

#### 9.3.2 Shear force

The shear force  $Q_H$  acting on the generic section of the rudder horn is to be obtained, in N, from the following formulae:

— between the lower and upper rudder horn bearings:

$$Q_H = F_{A1}$$

— above the rudder horn upper-bearing:

$$Q_H = F_{A1} + F_{A2}$$

where:

$F_{A1}, F_{A2}$  = Support forces, in N.

### 9.3.3 Torque

The torque acting on the generic section of the rudder horn is to be obtained, in N.m, from the following formulae:

— between the lower and upper rudder horn bearings:

$$M_T = F_{A1} e_{(z)}$$

— above the rudder horn upper-bearing:

$$M_T = F_{A1} e_{(z)} + F_{A2} e_{(z)}$$

where:

$F_{A1}, F_{A2}$  = Support forces, in N

$e_{(z)}$  = Torsion lever, in m, defined in Fig 19.

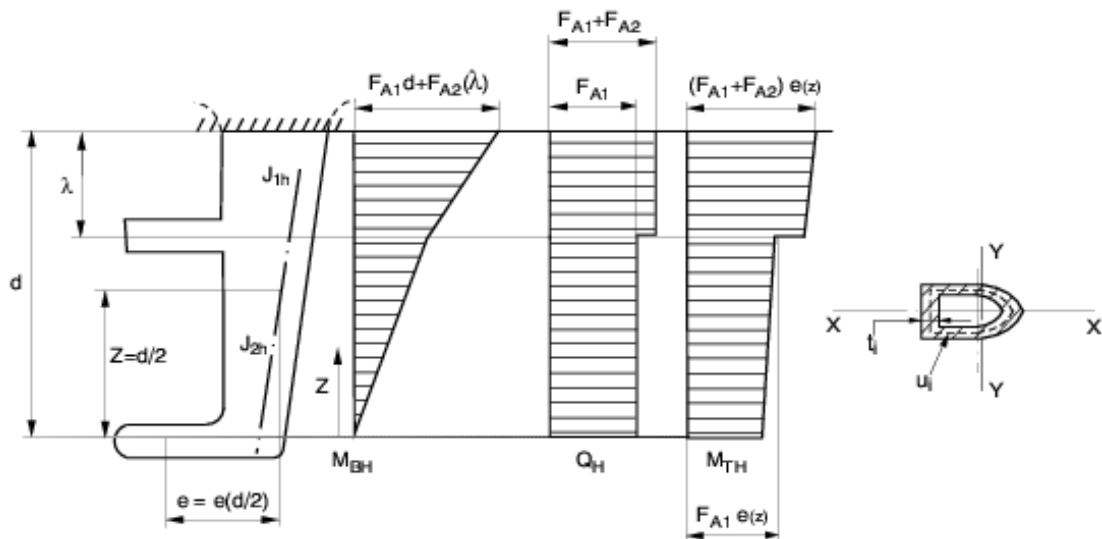

**Fig. 19**  
**Geometry of rudder horn**

### 9.3.4 Shear stress calculation

a) For a generic section of the rudder horn, located between its lower and upper bearings, the following stresses are to be calculated:

$\tau_S$  = Shear stress, in N/mm<sup>2</sup>, to be obtained from the following formula:

$$\tau_S = \frac{F_{A1}}{A_H}$$

$\tau_T$  = Torsional stress, in N/mm<sup>2</sup>, to be obtained for hollow rudder horn from the following formula:

$$\tau_T = \frac{M_T 10^3}{2F_T t_H}$$

For solid rudder horn,  $\tau_T$  is to be considered by the Society on a case by case basis

a) For a generic section of the rudder horn, located in the region above its upper bearing, the following stresses are to be calculated:

$\tau_S$  = Shear stress, in N/mm<sup>2</sup>, to be obtained from the following formula:

$$\tau_S = \frac{F_{A1} + F_{A2}}{A_H}$$

$\tau_T$  = Torsional stress, in N/mm<sup>2</sup>, to be obtained for hollow rudder horn from the following formula:

$$\tau_T = \frac{M_T 10^3}{2F_T t_H}$$

For solid rudder horn,  $\tau_T$  is to be considered by the Society on a case by case basis where:

- $F_{A1}, F_{A2}$  = Support forces, in N  
 $A_H$  = Effective shear sectional area of the rudder horn, in mm<sup>2</sup>, in  $y$ -direction  
 $M_T$  = Torque, in N.m  
 $F_T$  = Mean of areas enclosed by outer and inner boundaries of the thin walled section of rudder horn, in m<sup>2</sup>  
 $t_H$  = Plate thickness of rudder horn, in mm. For a given cross section of the rudder horn, the maximum value of  $\tau_T$  is obtained at the minimum value of  $t_H$ .

### 9.3.5 Bending stress calculation

For the generic section of the rudder horn within the length  $d$ , defined in Fig 14, the following stresses are to be calculated:

$\sigma_B$  = Bending stress, in N/mm<sup>2</sup>, to be obtained from the following formula:

$$\sigma_B = \frac{M_H}{W_X}$$

- $M_H$  = Bending moment at the section considered, in N.m  
 $W_X$  = Section modulus, in cm<sup>3</sup>, around the  $X$ -axis (see Fig 19).

### 9.3.6 General remarks

Requirements [9.2.5] to [9.2.10] also apply to rudder horn with 2-conjugate elastic supports.

## 10 Rudder coupling flanges

### 10.1

#### 10.1.1

Unless forged or cast steel flanges with integrally forged or cast welding flanges are used, horizontal rudder coupling flanges are to be joined to the rudder body by plates of graduated thickness and full penetration single or double-bevel welds as prescribed in Ch 11, Sec 1 (see Fig 20).

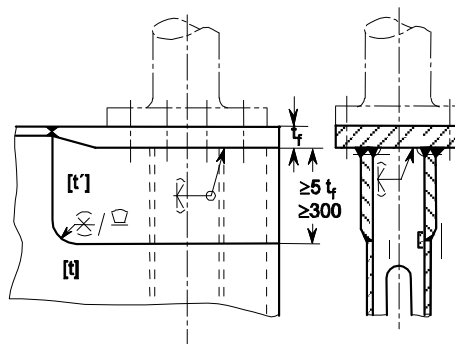

- $t$  = thickness of rudder plating, in mm  
 $t_f$  = actual flange thickness in [mm]  
 $t' = \frac{t_f}{3} + 5$  [mm] where  $t_f < 50$ mm  
 $t' = 3\sqrt{t_f}$  [mm] where  $t_f \geq 50$ mm

Fig. 20  
Horizontal rudder coupling flanges

### 10.1.2

Allowance is to be made for the reduced strength of the coupling flange in the thickness direction. In case of doubt, proof by calculation of the adequacy of the welded connection shall be produced.

### 10.1.3

The welded joint between the rudder stock (with thickened collar, see Ch 11, Sec 2) and the flange is to be made in accordance with Fig 21.

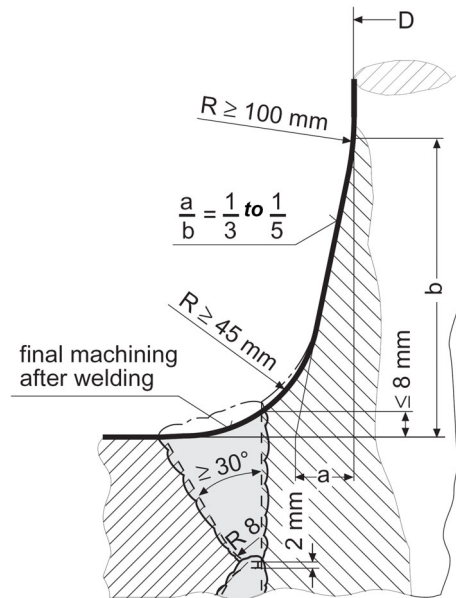

Fig. 21  
Welded joint between rudder stock and coupling flange

## 11 Azimuth propulsion system

### 11.1 General

#### 11.1.1 Arrangement

The azimuth propulsion system is constituted by the following sub-systems (see Fig 22):

- the steering unit
- the bearing
- the hull supports
- the rudder part of the system
- the pod, which contains the electric motor in the case of a podded propulsion system.

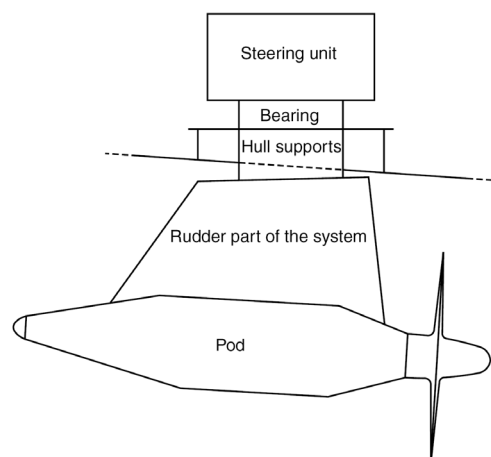

Fig. 22  
Azimuth propulsion system



### **11.1.2 Application**

The requirements of this Article apply to the scantlings of the hull supports, the rudder part and the pod. The steering unit and the bearing are to comply with the relevant requirements of the Society's Rules.

### **11.1.3 Operating conditions**

The maximum angle at which the azimuth propulsion system can be oriented on each side when the ship navigates at its maximum speed is to be specified by the Designer. Such maximum angle is generally to be less than 35° on each side.

In general, orientations greater than this maximum angle may be considered by the Society for azimuth propulsion systems during manoeuvres, provided that the orientation values together with the relevant speed values are submitted to the Society for approval.

## **11.2 Arrangement**

### **11.2.1 Plans to be submitted**

In addition to the plans showing the structural arrangement of the pod and the rudder part of the system, the plans showing the arrangement of the azimuth propulsion system supports are to be submitted to the Society for approval. The scantlings of the supports and the maximum loads which act on the supports are to be specified in these drawings.

### **11.2.2 Locking device**

The azimuth propulsion system is to be mechanically lockable in a fixed position, in order to avoid rotations of the system and propulsion in undesirable directions in the event of damage.

## **11.3 Design loads**

### **11.3.1**

The lateral pressure to be considered for scantling of plating and ordinary stiffeners of the azimuth propulsion system is to be determined for an orientation of the system equal to the maximum angle at which the azimuth propulsion system can be oriented on each side when the ship navigates at its maximum speed.

- The total force which acts on the azimuth propulsion system is to be obtained by integrating the lateral pressure on the external surface of the system.
- The calculations of lateral pressure and total force are to be submitted to the Society for information.

## **11.4 Plating**

### **11.4.1 Plating of the rudder part of the azimuth propulsion system**

The thickness of plating of the rudder part of the azimuth propulsion system is to be not less than that obtained, in mm, from the formulae in [5.2.1], in which the term  $C_R/A$  is to be replaced by the lateral pressure calculated according to [11.3].

### **11.4.2 Plating of the pod**

The thickness of plating of the pod is to be not less than that obtained, in mm, from the formulae in Ch 6, Sec 1 or Ch 9, Sec 2, where the lateral pressure is to be calculated according to [11.3].

### **11.4.3 Webs**

The thickness of webs of the rudder part of the azimuth propulsion system is to be determined according to [5.2.3], where the lateral pressure is to be calculated according to [11.3].

## **11.5 Ordinary stiffeners**

### **11.5.1 Ordinary stiffeners of the pod**

The scantlings of ordinary stiffeners of the pod are to be not less than those obtained from the formulae in Ch 6, Sec 2 or Ch 9, Sec 2, where the lateral pressure is to be calculated according to [11.3].

## **11.6 Primary supporting members**

### **11.6.1 Analysis criteria**

The scantlings of primary supporting members of the azimuth propulsion system are to be obtained by the

Designer through direct calculations, to be carried out according to the following requirements:

- the structural model is to include the pod, the rudder part of the azimuth propulsion system, the bearing and the hull supports
- the boundary conditions are to represent the connections of the azimuth propulsion system to the hull structures
- the loads to be applied are those defined in [11.6.2].
- The direct calculation analyses (structural model, load and stress calculation, strength checks) carried out by the Designer are to be submitted to the Society for information.

### 11.6.2 Loads

The following loads are to be considered by the Designer in the direct calculation of the primary supporting members of the azimuth propulsion system:

- gravity loads
- buoyancy
- maximum loads calculated for an orientation of the system equal to the maximum angle at which the azimuth propulsion system can be oriented on each side when the ship navigates at its maximum speed
- maximum loads calculated for the possible orientations of the system greater than the maximum angle at the relevant speed (see [11.1.3])
- maximum loads calculated for the crash stop of the ship obtained through inversion of the propeller rotation
- maximum loads calculated for the crash stop of the ship obtained through a 180°/rotation of the pod.

### 11.6.3 Strength check

It is to be checked that the Von Mises equivalent stress  $\sigma_E$  in primary supporting members, calculated, in N/mm<sup>2</sup>, for the load cases defined in [11.6.2], is in compliance with the following formula:

$$\sigma_E \leq \sigma_{ALL}$$

where:

$\sigma_{ALL}$  = Allowable stress, in N/mm<sup>2</sup>, to be taken equal to the lesser of the following values:

$$\sigma_{ALL} = 0.275R_m$$

$$\sigma_{ALL} = 0.55R_{eH}$$

## 11.7 Hull supports of the azimuth propulsion system

### 11.7.1 Analysis criteria

The scantlings of hull supports of the azimuth propulsion system are to be obtained by the Designer through direct calculations, to be carried out in accordance with the requirements in [11.6.1].

### 11.7.2 Loads

The loads to be considered in the direct calculation of the hull supports of the azimuth propulsion system are those specified in [11.6.2].

### 11.7.3 Strength check

It is to be checked that the Von Mises equivalent stress  $\sigma_E$  in hull supports, in N/mm<sup>2</sup>, calculated for the load cases defined in [11.6.2], is in compliance with the following formula:

$$\sigma_E \leq \sigma_{ALL}$$

where:

$\sigma_{ALL}$  = Allowable stress, in N/mm<sup>2</sup>, equal to  $65 / k_r$

$k_r$  = Material factor, defined in [1.4.2]

Values of  $\sigma_E$  greater than  $\sigma_{ALL}$  may be accepted by the Society on a case by case basis, depending on the localisation of  $\sigma_E$  and on the type of direct calculation analysis.

## **SECTION 2 BULWARKS AND GUARD RAILS**

### **1 General**

#### **1.1 Introduction**

##### **1.1.1**

The requirements of this Section apply to the arrangement of bulwarks and guard rails provided at boundaries of the freeboard deck, superstructure decks and tops of the first tier of deckhouses located on the freeboard deck.

#### **1.2 General**

##### **1.2.1**

Efficient bulwarks or guard rails are to be fitted at the boundaries of all exposed parts of the freeboard deck and superstructure decks directly attached to the freeboard deck, as well as the first tier of deckhouses fitted on the freeboard deck and the superstructure ends.

##### **1.2.2**

The height of the bulwarks or guard rails is to be at least 1 m from the deck. However, where their height would interfere with the normal operation of the ship, a lesser height may be accepted, if adequate protection is provided and subject to any applicable statutory requirement.

##### **1.2.3**

Where superstructures are connected by trunks, open rails are to be fitted for the whole length of the exposed parts of the freeboard deck.

##### **1.2.4**

In type B-100 ships, open rails on the weather parts of the freeboard deck for at least half the length of the exposed parts are to be fitted.

Alternatively, freeing ports complying with Ch 9, Sec 6, [5.5.2] are to be fitted.

##### **1.2.5**

In ships with bulwarks and trunks of breadth not less than  $0.6B$ , which are included in the calculation of freeboard, open rails on the weather parts of the freeboard deck in way of the trunk for at least half the length of the exposed parts are to be fitted.

Alternatively, freeing ports complying with Ch 9, Sec 6, [5.3.1] are to be fitted.

##### **1.2.6**

In ships having superstructures which are open at either or both ends, adequate provision for freeing the space within such superstructures is to be provided.

##### **1.2.7**

The freeing port area in the lower part of the bulwarks is to be in compliance with the applicable requirements of Ch 9, Sec 6, [5].

### **2 Bulwarks**

#### **2.1 General**

##### **2.1.1**

As a rule, plate bulwarks are to be stiffened at the upper edge by a suitable bar and supported either by stays or plate brackets spaced not more than 2.0 m apart.

The free edge of the stay or the plate bracket is to be stiffened.

Stay and brackets of bulwarks are to be aligned with the beams located below or are to be connected to them by means of local transverse stiffeners.

As an alternative, the lower end of the stay and bracket may be supported by a longitudinal stiffener.

### 2.1.2

In type B-60 and B-100 ships, the spacing forward of  $0.07L$  from the fore end of brackets and stays is to be not greater than 1.2 m.

### 2.1.3

Where bulwarks are cut completely, the scantlings of stays or brackets are to be increased with respect to those given in [2.2].

### 2.1.4

As a rule, bulwarks are not to be connected either to the upper edge of the sheerstrake plate or to the stringer plate.

Failing this, the detail of the connection will be examined by the Society.

## 2.2 Scantlings

### 2.2.1

The gross thickness of bulwarks on the freeboard deck not exceeding 1 m in height is to be not less than 6.5 mm.

Where the height of the bulwark is equal to or greater than 1.8 m, its thickness is to be equal to that calculated for the side of a superstructure situated in the same location as the bulwark.

For bulwarks between 1 m and 1.8 m in height, their thickness is to be calculated by linear interpolation.

### 2.2.2

Bulwark plating and stays are to be adequately strengthened in way of eye plates used for shrouds or other tackles in use for cargo gear operation, as well as in way of hawser holes or fairleads provided for mooring or towing.

### 2.2.3

At the ends of partial superstructures and for the distance over which their side plating is tapered into the bulwark, the latter is to have the same thickness as the side plating. Where openings are cut in the bulwark at these positions, adequate compensation is to be provided either by increasing the thickness of the plating or by other suitable means.

### 2.2.4

The gross section modulus of stays in way of the lower part of the bulwark is to be not less than the value obtained, in  $\text{cm}^3$ , from the following formula:

$$w = 77sh_B^2$$

where:

$s$  = Spacing of stays, in m

$h_B$  = Height of bulwark, in m, measured from the top of the deck plating to the upper edge.

The actual section of the connection between stays and deck structures is to be taken into account when calculating the above section modulus.

To this end, the bulb or face plate of the stay may be taken into account only where welded to the deck; in this case the beam located below is to be connected by double continuous welding.

For stays with strengthening members not connected to the deck, the calculation of the required section modulus is considered by the Society on a case by case basis.

At the ends of the ship, where the bulwark is connected to the sheerstrake, an attached plating having a width not exceeding 600 mm may also be included in the calculation of the actual gross section modulus of stays.

### 2.2.5

Openings in bulwarks are to be arranged so that the protection of the crew is to be at least equivalent to that provided by the horizontal courses in [3.1.2].

For this purpose, vertical rails or bars spaced approximately 230 mm apart may be accepted in lieu of rails or bars arranged horizontally.

### **2.2.6**

In the case of ships intended for the carriage of timber deck cargoes, the specific provisions of the freeboard regulations are to be complied with.

## **3 Guard rails**

### **3.1 General**

#### **3.1.1**

Where guard rails are provided, the upper edge of sheerstrake is to be kept as low as possible.

#### **3.1.2**

The opening below the lowest course is to be not more than 230 mm. The other courses are to be not more than 380 mm apart.

#### **3.1.3**

In the case of ships with rounded gunwales or sheerstrake, the stanchions are to be placed on the flat part of the deck.

#### **3.1.4**

Fixed, removable or hinged stanchions are to be fitted about 1.5 m apart. At least every third stanchion is to be supported by a bracket or stay.

Removable or hinged stanchions are to be capable of being locked in the upright position.

#### **3.1.5**

Wire ropes may only be accepted in lieu of guard rails in special circumstances and then only in limited lengths. Wires are to be made taut by means of turnbuckles.

#### **3.1.6**

Chains may only be accepted in short lengths in lieu of guard rails if they are fitted between two fixed stanchions and/or bulwarks.

## SECTION 3 EQUIPMENT

### Symbols

For symbols not defined in this Section, refer to Ch 1, Sec 4.

$EN$  = Equipment number defined in [2.1]

## 1 General

### 1.1 General

#### 1.1.1

The requirements in this Section apply to temporary mooring of a ship within or near harbour, or in a sheltered area, when the ship is awaiting a berth, the tide, etc..

Therefore, the equipment complying with the requirements in this Section is not intended for holding a ship off fully exposed coasts in rough weather or for stopping a ship which is moving or drifting.

#### 1.1.2

The equipment complying with the requirements in this Section is intended for holding a ship in good holding ground, where the conditions are such as to avoid dragging of the anchor. In poor holding ground the holding power of the anchors is to be significantly reduced.

#### 1.1.3

The equipment number  $EN$  formula for anchoring equipment required here under is based on an assumed current speed of 2.5 m/s, wind speed of 25 m/s and a scope of chain cable between 6 and 10, the scope being the ratio between length of chain paid out and water depth.

#### 1.1.4

It is assumed that under normal circumstances a ship will use one anchor only.

## 2 Equipment number

### 2.1 Equipment number

#### 2.1.1 General

All ships are to be provided with equipment in anchors and chain cables (or ropes according to [3.3.5]), to be obtained from Table 1, based on their equipment number  $EN$ .

In general, stockless anchors are to be adopted.

For ships with  $EN$  greater than 16000, the determination of the equipment will be considered by the Society on a case by case basis.

Table 1 Equipment							
Equipment number $EN$ $A < EN \leq B$		Stockless anchors		Stud link chain cables for anchors			
		$N^{(1)}$	Mass per anchor, in kg	Total length, in m	Diameter, in mm		
Grade 1	Grade 2				Grade 3		
$A$	$B$						
50	70	2	180	220.0	14.0	12.5	
70	90	2	240	220.0	16.0	14.0	
90	110	2	300	247.5	17.5	16.0	
110	130	2	360	247.5	19.0	17.5	
130	150	2	420	275.0	20.5	17.5	
150	175	2	480	275.0	22.0	19.0	

<b>Table 1 Equipment (Continued)</b>							
<i>Equipment number</i> <i>EN</i> <i>A &lt; EN ≤ B</i>		<i>Stockless anchors</i>		<i>Stud link chain cables for anchors</i>			
		<i>N<sup>(1)</sup></i>	<i>Mass per anchor, in kg</i>	<i>Total length, in m</i>	<i>Diameter, in mm</i>		
<i>A</i>	<i>B</i>				<i>Grade 1</i>	<i>Grade 2</i>	<i>Grade 3</i>
175	205	2	570	302.5	24.0	20.5	
205	240	3	660	302.5	26.0	22.0	20.5
240	280	3	780	330.0	28.0	24.0	22.0
280	320	3	900	357.5	30.0	26.0	24.0
320	360	3	1020	357.5	32.0	28.0	24.0
360	400	3	1140	385.0	34.0	30.0	26.0
400	450	3	1290	385.0	36.0	32.0	28.0
450	500	3	1440	412.5	38.0	34.0	30.0
500	550	3	1590	412.5	40.0	34.0	30.0
550	600	3	1740	440.0	42.0	36.0	32.0
600	660	3	1920	440.0	44.0	38.0	34.0
660	720	3	2100	440.0	46.0	40.0	36.0
720	780	3	2280	467.5	48.0	42.0	36.0
780	840	3	2460	467.5	50.0	44.0	38.0
840	910	3	2640	467.5	52.0	46.0	40.0
910	980	3	2850	495.0	54.0	48.0	42.0
980	1060	3	3060	495.0	56.0	50.0	44.0
1060	1140	3	3300	495.0	58.0	50.0	46.0
1140	1220	3	3540	522.5	60.0	52.0	46.0
1220	1300	3	3780	522.5	62.0	54.0	48.0
1300	1390	3	4050	522.5	64.0	56.0	50.0
1390	1480	3	4320	550.0	66.0	58.0	50.0
1480	1570	3	4590	550.0	68.0	60.0	52.0
1570	1670	3	4890	550.0	70.0	62.0	54.0
1670	1790	3	5250	577.5	73.0	64.0	56.0
1790	1930	3	5610	577.5	76.0	66.0	58.0
1930	2080	3	6000	577.5	78.0	68.0	60.0
2080	2230	3	6450	605.0	81.0	70.0	62.0
2230	2380	3	6900	605.0	84.0	73.0	64.0
2380	2530	3	7350	605.0	87.0	76.0	66.0
2530	2700	3	7800	632.5	90.0	78.0	68.0
2700	2870	3	8300	632.5	92.0	81.0	70.0
2870	3040	3	8700	632.5	95.0	84.0	73.0
3040	3210	3	9300	660.0	97.0	84.0	76.0
3210	3400	3	9900	660.0	100.0	87.0	78.0
3400	3600	3	10500	660.0	102.0	90.0	78.0
3600	3800	3	11100	687.5	105.0	92.0	81.0
3800	4000	3	11700	687.5	107.0	95.0	84.0
4000	4200	3	12300	687.5	111.0	97.0	87.0
4200	4400	3	12900	715.0	114.0	100.0	87.0
4400	4600	3	13500	715.0	117.0	102.0	90.0
4600	4800	3	14100	715.0	120.0	105.0	92.0
4800	5000	3	14700	742.5	122.0	107.0	95.0
5000	5200	3	15400	742.5	124.0	111.0	97.0
5200	5500	3	16100	742.5	127.0	111.0	97.0
5500	5800	3	16900	742.5	130.0	114.0	100.0
5800	6100	3	17800	742.5	132.0	117.0	102.0
6100	6500	3	18800	742.5		120.0	107.0
6500	6900	3	20000	770.0		124.0	111.0
6900	7400	3	21500	770.0		127.0	114.0
7400	7900	3	23000	770.0		132.0	117.0

Equipment number <i>EN</i> $A < EN \leq B$		Stockless anchors		Stud link chain cables for anchors			
		<i>N</i> <sup>(1)</sup>	Mass per anchor, in kg	Total length, in m	Diameter, in mm		
<i>A</i>	<i>B</i>				Grade 1	Grade 2	Grade 3
7900	8400	3	24500	770.0		137.0	122.0
8400	8900	3	26000	770.0		142.0	127.0
8900	9400	3	27500	770.0		147.0	132.0
9400	10000	3	29000	770.0		152.0	132.0
10000	10700	3	31000	770.0			137.0
10700	11500	3	33000	770.0			142.0
11500	12400	3	35500	770.0			147.0
12400	13400	3	38500	770.0			152.0
13400	14600	3	42000	770.0			157.0
14600	16000	3	46000	770.0			162.0

<sup>(1)</sup> See [3.2.4].

### 2.1.2 Equipment number

The equipment number *EN* is to be obtained from the following formula:

$$EN = \Delta^{2/3} + 2 h B + 0.1 A$$

where:

$\Delta$  = Moulded displacement of the ship, in t, to the summer load waterline

*h* = Effective height, in m, from the summer load waterline to the top of the uppermost house, to be obtained in accordance with the following formula:

$$h = a + \sum h_n$$

When calculating *h*, sheer and trim are to be disregarded

*a* = Freeboard amidships from the summer load waterline to the upper deck, in m

*h<sub>n</sub>* = Height, in m, at the centreline of tier “*n*” of superstructures or deckhouses having a breadth greater than *B*/4. Where a house having a breadth greater than *B*/4 is above a house with a breadth of *B*/4 or less, the upper house is to be included and the lower ignored

*A* = Area, in m<sup>2</sup>, in profile view, of the parts of the hull, superstructures and houses above the summer load waterline which are within the length *L* and also have a breadth greater than *B*/4

Fixed screens or bulwarks 1.5 m or more in height are to be regarded as parts of houses when determining *h* and *A*. In particular, the hatched area shown in Fig 1 is to be included.

The height of hatch coamings and that of any deck cargo, such as containers, may be disregarded when determining *h* and *A*.

## 3 Equipment

### 3.1 General

#### 3.1.1

All anchoring equipment, towing bits, mooring bollards, fairlead cleats and eyebolts are to be so constructed and attached to the hull that, in use up to design loads, the integrity of the ship will not be impaired.

#### 3.1.2

The anchoring arrangement is to be such as to prevent the cable from being damaged and fouled. Adequate arrangement is to be provided to secure the anchor under all operational conditions.

### 3.2 Anchors

#### 3.2.1 General

The scantlings of anchors are to be in compliance with the following requirements.



Anchors are to be constructed and tested in compliance with approved plans.

### 3.2.2 Ordinary anchors

The required mass for each anchor is to be obtained from Tab 1.

The individual mass of a main anchor may differ by  $\pm 7\%$  from the mass required for each anchor, provided that the total mass of anchors is not less than the total mass required in Table 1.

The mass of the head of an ordinary stockless anchor, including pins and accessories, is to be not less than 60% of the total mass of the anchor.

Where a stock anchor is provided, the mass of the anchor, excluding the stock, is to be not less than 80% of the mass required in Table 1 for a stockless anchor. The mass of the stock is to be not less than 25% of the mass of the anchor without the stock but including the connecting shackle.

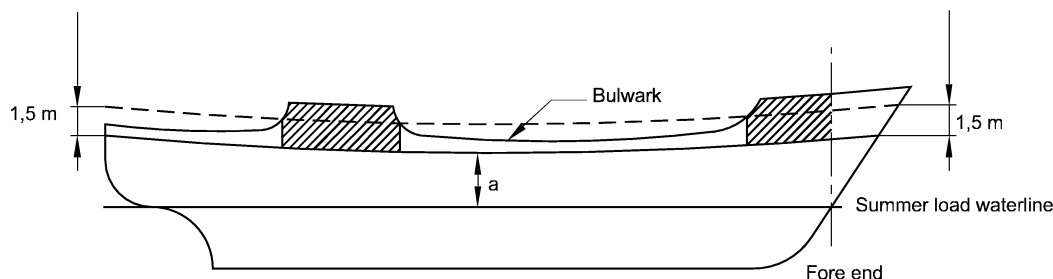

**Fig. 1**  
Effective area of bulwarks or fixed screen to be included in the equipment number

### 3.2.3 High and very high holding power anchors

High holding power (HHP) and very high holding power (VHHP) anchors, i.e. anchors for which a holding power higher than that of ordinary anchors has been proved according to the applicable requirements of the Society's Rules for Materials, do not require prior adjustment or special placement on the sea bottom.

Where HHP or VHHP anchors are used as bower anchors, the mass of each anchor is to be not less than 75% or 50%, respectively, of that required for ordinary stockless anchors in Table 1.

The mass of VHHP anchors is to be, in general, less than or equal to 1 500 kg.

### 3.2.4 Third anchor

Where three anchors are provided, two are to be connected to their own chain cables and positioned on board always ready for use.

The third anchor is intended as a spare and is not required for the purpose of classification.

### 3.2.5 Test for high holding power anchors approval

For approval and/or acceptance as a HHP anchor, comparative tests are to be performed on various types of sea bottom.

Such tests are to show that the holding power of the HHP anchor is at least twice the holding power of an ordinary stockless anchor of the same mass.

For approval and/or acceptance as a HHP anchor of a whole range of mass, such tests are to be carried out on anchors whose sizes are, as far as possible, representative of the full range of masses proposed. In this case, at least two anchors of different sizes are to be tested. The mass of the maximum size to be approved is to be not greater than 10 times the maximum size tested. The mass of the smallest is to be not less than 0.1 times the minimum size tested.

### 3.2.6 Test for very high holding power anchors approval

For approval and/or acceptance as a VHHP anchor, comparative tests are to be performed at least on three types of sea bottom: soft mud or silt, sand or gravel and hard clay or similar compounded material. Such tests are to show that the holding power of the VHHP anchor is to be at least four times the holding power of an ordinary stockless anchor of the same mass or at least twice the holding power of a previously approved HHP anchor of the same mass. The holding power test load is to be less than or equal to the proof load of the anchor, specified in the applicable requirements of the Society's Rules for Materials.

For approval and/or acceptance as a VHHP anchor of a whole range of mass, such tests are to be carried out on

anchors whose sizes are, as far as possible, representative of the full range of masses proposed. In this case, at least three anchors of different sizes are to be tested, relevant to the bottom, middle and top of the mass range.

### **3.2.7 Specification for test on high holding power and very high holding power anchors**

Tests are generally to be carried out from a tug. Shore based tests may be accepted by the Society on a case by case basis.

Alternatively, sea trials by comparison with a previous approved anchor of the same type (HHP or VHHP) of the one to be tested may be accepted by the Society on a case by case basis.

For each series of sizes, the two anchors selected for testing (ordinary stockless and HHP anchors for testing HHP anchors, ordinary stockless and VHHP anchors or, when ordinary stockless anchors are not available, HHP and VHHP anchors for testing VHHP anchors) are to have the same mass.

The length of chain cable connected to each anchor, having a diameter appropriate to its mass, is to be such that the pull on the shank remains practically horizontal. For this purpose a value of the ratio between the length of the chain cable paid out and the water depth equal to 10 is considered normal. A lower value of this ratio may be accepted by the Society on a case by case basis.

Three tests are to be carried out for each anchor and type of sea bottom.

The pull is to be measured by dynamometer; measurements based on the RPM/bollard pull curve of tug may, however, be accepted instead of dynamometer readings.

Note is to be taken where possible of the stability of the anchor and its ease of breaking out.

## **3.3 Chain cables for anchors**

### **3.3.1 Material**

The chain cables are classified as grade 1, 2 or 3 depending on the type of steel used and its manufacture.

The characteristics of the steel used and the method of manufacture of chain cables are to be approved by the Society for each manufacturer. The material from which chain cables are manufactured and the completed chain cables themselves are to be tested in accordance with the applicable requirements of the Society's Rules for Materials.

Chain cables made of grade 1 may not be used with high holding power and very high holding power anchors.

### **3.3.2 Scantlings of stud link chain cables**

The mass and geometry of stud link chain cables, including the links, are to be in compliance with the requirements in the applicable requirements of the Society's Rules for Materials.

The diameter of stud link chain cables is to be not less than the value in Table 1.

### **3.3.3 Studless link chain cables**

For ships with *EN* less than 90, studless short link chain cables may be accepted by the Society as an alternative to stud link chain cables, provided that the equivalence in strength is based on proof load, defined in the applicable requirements of the Society's Rules for Materials and that the steel grade of the studless chain is equivalent to the steel grade of the stud chains it replaces, as defined in [3.3.1].

### **3.3.4 Chain cable arrangement**

Chain cables are to be made by lengths of 27.5 m each, joined together by Dee or lugless shackles.

The total length of chain cable, required in Table 1, is to be divided in approximately equal parts between the two anchors ready for use.

Where different arrangements are provided, they are considered by the Society on a case by case basis.

Where the ship may anchor in areas with current speed greater than 2.5 m/s, the Society may require a length of heavier chain cable to be fitted between the anchor and the rest of the chain in order to enhance anchor bedding.

### **3.3.5 Wire ropes**

As an alternative to the stud link or short link chain cables mentioned, wire ropes may be used in the following cases:

- wire ropes for both the anchors, for ship length less than 30 m
- wire rope for one of the two anchors, for ship length between 30 m and 40 m.

The wire ropes above are to have a total length equal to 1.5 times the corresponding required length of stud link chain cables, obtained from Table 1, and a minimum breaking load equal to that given for the corresponding stud link chain cable (see [3.3.2]).

A short length of chain cable is to be fitted between the wire rope and the anchor, having a length equal to 12.5 m or the distance from the anchor in the stowed position to the winch, whichever is the lesser.

### 3.4 Attachment pieces

#### 3.4.1 General

Where the lengths of chain cable are joined to each other by means of shackles of the ordinary Dee type, the anchor may be attached directly to the end link of the first length of chain cable by a Dee type end shackle.

A detachable open link in two parts riveted together may be used in lieu of the ordinary Dee type end shackle; in such case the open end link with increased diameter, defined in [3.4.2], is to be omitted.

Where the various lengths of chain cable are joined by means of lugless shackles and therefore no special end and increased diameter links are provided, the anchor may be attached to the first length of chain cable by a special pear-shaped lugless end shackle or by fitting an attachment piece.

#### 3.4.2 Scantlings

The diameters of the attachment pieces, in mm, are to be not less than the values indicated in Table 2.

Attachment pieces may incorporate the following items between the increased diameter stud link and the open end link:

- swivel, having a diameter equal to  $1.2d$
- increased stud link, having a diameter equal to  $1.1d$

Where different compositions are provided, they will be considered by the Society on a case by case basis.

<i>Attachment piece</i>	<i>Diameter, in mm</i>
End shackle	$1.4d$
Open end link	$1.2d$
Increased stud link	$1.1d$
Common stud link	$d$
Lugless shackle	$d$
where:	
$d$ = Diameter, in mm, of the common link.	

#### 3.4.3 Material

Attachment pieces, joining shackles and end shackles are to be of such material and design as to provide strength equivalent to that of the attached chain cable, and are to be tested in accordance with the applicable requirements of the applicable requirements of the Society's Rules for Materials.

#### 3.4.4 Spare attachment pieces

A spare pear-shaped lugless end shackle or a spare attachment piece is to be provided for use when the spare anchor is fitted in place.

### 3.5 Towlines and mooring lines

#### 3.5.1 General

The towlines having the characteristics defined in Table 3 are intended as those belonging to the ship to be towed by a tug or another ship.

#### 3.5.2 Materials

Towlines and mooring lines may be of wire, natural or synthetic fibre or a mixture of wire and fibre.

The breaking loads defined in Table 3 refer to steel wires or natural fibre ropes.

Steel wires and fibre ropes are to be tested in accordance with the applicable requirements in the applicable requirements of the Society's Rules for Materials.

### 3.5.3 Steel wires

Steel wires are to be made of flexible galvanised steel and are to be of types defined in Table 4.

Where the wire is wound on the winch drum, steel wires to be used with mooring winches may be constructed with an independent metal core instead of a fibre core. In general such wires are to have not less than 186 threads in addition to the metallic core.

Equipment number <i>EN</i> $A < EN \leq B$		Towline <sup>(1)</sup>		Mooring lines		
<i>A</i>	<i>B</i>	Minimum length, in m	Breaking load, in kN	<i>N</i> <sup>(2)</sup>	Length of each line, in m	Breaking load, in kN
50	70	180	98.1	3	80	34
70	90	180	98.1	3	100	37
90	110	180	98.1	3	110	39
110	130	180	98.1	3	110	44
130	150	180	98.1	3	120	49
150	175	180	98.1	3	120	54
175	205	180	112	3	120	59
205	240	180	129	4	120	64
240	280	180	150	4	120	69
280	320	180	174	4	140	74
320	360	180	207	4	140	78
360	400	180	224	4	140	88
400	450	180	250	4	140	98
450	500	180	277	4	140	108
500	550	190	306	4	160	123
550	600	190	338	4	160	132
600	660	190	371	4	160	147
660	720	190	406	4	160	157
720	780	190	441	4	170	172
780	840	190	480	4	170	186
840	910	190	518	4	170	201
910	980	190	550	4	170	216
980	1060	200	603	4	180	230
1060	1140	200	647	4	180	250
1140	1220	200	692	4	180	270
1220	1300	200	739	4	180	284
1300	1390	200	786	4	180	309
1390	1480	200	836	4	180	324
1480	1570	220	889	5	190	324
1570	1670	220	942	5	190	333
1670	1790	220	1024	5	190	353
1790	1930	220	1109	5	190	378
1930	2080	220	1168	5	190	402
2080	2230	240	1259	5	200	422
2230	2380	240	1356	5	200	451
2380	2530	240	1453	5	200	481
2530	2700	260	1471	6	200	481
2700	2870	260	1471	6	200	490
2870	3040	260	1471	6	200	500
3040	3210	280	1471	6	200	520
3210	3400	280	1471	6	200	554
3400	3600	280	1471	6	200	588
3600	3800	300	1471	6	200	612
3800	4000	300	1471	6	200	647

Equipment number <i>EN</i> $A < EN \leq B$		Towline <sup>(1)</sup>		Mooring lines		
<i>A</i>	<i>B</i>	Minimum length, in m	Breaking load, in kN	<i>N</i> <sup>(2)</sup>	Length of each line, in m	Breaking load, in kN
4000	4200	300	1471	7	200	647
4200	4400	300	1471	7	200	657
4400	4600	300	1471	7	200	667
4600	4800	300	1471	7	200	677
4800	5000	300	1471	7	200	686
5000	5200	300	1471	8	200	686
5200	5500	300	1471	8	200	696
5500	5800	300	1471	8	200	706
5800	6100	300	1471	9	200	706
6100	6500			9	200	716
6500	6900			9	200	726
6900	7400			10	200	726
7400	7900			11	200	726
7900	8400			11	200	735
8400	8900			12	200	735
8900	9400			13	200	735
9400	10000			14	200	735
10000	10700			15	200	735
10700	11500			16	200	735
11500	12400			17	200	735
12400	13400			18	200	735
13400	14600			19	200	735
14600	16000			21	200	735

(1) The towline is not compulsory. It is recommended for ships having length not greater than 180 m.  
(2) See [3.5.4].

Breaking load <i>BL</i> , in kN	Steel wire components		
	Number of threads	Ultimate tensile strength of threads, in N/mm <sup>2</sup>	Composition of wire
$BL < 216$	72	1420 ÷ 1570	6 strands with 7-fibre core
$216 < BL < 490$	144	1570 ÷ 1770	6 strands with 7-fibre core
$BL > 490$	216 or 222	1770 ÷ 1960	6 strands with 1-fibre core

### 3.5.4 Number of mooring lines

When the breaking load of each mooring line is greater than 490 kN, either a greater number of mooring lines than those required in Table 3 having lower strength, or a lower number of mooring lines than those required in Table 3 having greater strength may be used, provided the total breaking load of all lines aboard the ship is greater than the value defined in Table 3.

In any case, the number of lines is to be not less than 6 and the breaking load of each line is to be greater than 490 kN.

### 3.5.5 Length of mooring lines

The length of individual mooring lines may be reduced by up to 7% of the length defined in Table 3, provided that the total length of mooring lines is greater than that obtained by adding the lengths of the individual lines defined in Table 3.

### 3.5.6 Equivalence between the breaking loads of synthetic and natural fibre ropes

Generally, fibre ropes are to be made of polyamide or other equivalent synthetic fibres.

The equivalence between the breaking loads of synthetic fibre ropes  $B_{LS}$  and of natural fibre ropes  $B_{LN}$  is to be

obtained, in kN, from the following formula:

$$B_{LS} = 7.4 \delta (B_{LN})^{8/9}$$

where:

$\delta$  = Elongation to breaking of the synthetic fibre rope, to be assumed not less than 30%.

### **3.6 Hawse pipes**

#### **3.6.1**

Hawse pipes are to be built according to sound marine practice.

Their position and slope are to be so arranged as to create an easy lead for the chain cables and efficient housing for the anchors, where the latter are of the retractable type, avoiding damage to the hull during these operations.

For this purpose chafing lips of suitable form with ample lay-up and radius adequate to the size of the chain cable are to be provided at the shell and deck. The shell plating in way of the hawse pipes is to be reinforced as necessary.

#### **3.6.2**

In order to obtain an easy lead of the chain cables, the hawse pipes may be provided with rollers. These rollers are to have a nominal diameter not less than 10 times the size of the chain cable where they are provided with full imprints, and not less than 12 times its size where provided with partial imprints only.

#### **3.6.3**

All mooring units and accessories, such as tumbler, riding and trip stoppers are to be securely fastened to the Surveyor's satisfaction.

### **3.7 Windlass**

#### **3.7.1 General**

The windlass, which is generally single, is to be power driven and suitable for the size of chain cable and the mass of the anchors.

The windlass is to be fitted in a suitable position in order to ensure an easy lead of the chain cables to and through the hawse pipes. The deck in way of the windlass is to be suitably reinforced.

#### **3.7.2 Assumptions for the calculation of the continuous duty pull**

The calculation of the continuous duty pull  $P_C$  that the windlass unit prime mover is to be able to supply is based on the following assumptions:

- ordinary stockless anchors
- wind force equal to 6 on Beaufort Scale
- water current velocity 3 knots
- anchorage depth 100 m
- $P_C$  includes the influences of buoyancy and hawse pipe efficiency; the latter is assumed equal to 70%
- the anchor masses assumed are those defined in the applicable requirements of the Society's Rules for Materials, excluding tolerances
- only one anchor is assumed to be raised at a time.

Owing to the buoyancy, the chain masses assumed are smaller than those defined in the applicable requirements of the Society's Rules for Materials, and are obtained, per unit length of the chain cable, in kg/m, from the following formula:

$$m_L = 0.0218 d^2$$

where  $d$  is the chain cable diameter, in mm.

#### **3.7.3 Calculation of the continuous duty pull**

According to the assumptions in [3.7.2], the windlass unit prime mover is to be able to supply for a least 30

minutes a continuous duty pull  $P_C$  to be obtained, in kN, from Table 5.

<b>Table 5 Continuous duty pull</b>	
<i>Material of chain cables</i>	<i>Continuous duty pull, in kN</i>
Mild steel	$P_C = 0.0375 d^2$
High tensile strength steel	$P_C = 0.0425 d^2$
Very high tensile strength steel	$P_C = 0.0475 d^2$
where: $d$ = Chain cable diameter, in mm.	

### 3.7.4 Temporary overload capacity

The windlass unit prime mover is to provide the necessary temporary overload capacity for breaking out the anchor.

The temporary overload capacity, or short term pull, is to be not less than 1.5 times the continuous duty pull  $P_C$  and it is to be provided for at least two minutes.

The speed in this overload period may be lower than the nominal speed specified in [3.7.5].

### 3.7.5 Nominal hoisting speed

The nominal speed of the chain cable when hoisting the anchor and cable, to be assumed as an average speed, is to be not less than 0.15 m/s.

The speed is to be measured over two shots of chain cable during the entire trip; the trial is to commence with 3 shots (82.5 m) of chain fully submerged.

### 3.7.6 Windlass brake

A windlass brake is to be provided having sufficient capacity to stop the anchor and chain cable when paying out the latter with safety, in the event of failure of the power supply to the prime mover. Windlasses not actuated by steam are also to be provided with a non-return device.

A windlass with brakes applied and the cable lifter declutched is to be able to withstand a pull of 45% of the breaking load of the chain without any permanent deformation of the stressed parts or brake slip.

### 3.7.7 Chain stoppers

Where a chain stopper is fitted, it is to be able to withstand a pull of 80% of the breaking load of the chain.

Where a chain stopper is not fitted, the windlass is to be able to withstand a pull of 80% of the breaking load of the chain without any permanent deformation of the stressed part or brake slip.

### 3.7.8 Green sea loads

Where the height of the exposed deck in way of the item is less than  $0.1L$  or 22 m above the summer load waterline, whichever is the lesser, the securing devices of windlasses located within the forward quarter length of the ship are to resist green sea forces.

The green sea pressure and associated areas are to be taken equal to (see Fig 2):

- 200 kN/m<sup>2</sup> normal to the shaft axis and away from the forward perpendicular, over the projected area in this direction
- 150 kN/m<sup>2</sup> parallel to the shaft axis and acting both inboard and outboard separately, over the multiple of  $f$  times the projected area in this direction,

where:

$f$  = Coefficient taken equal to

$$f = 1 + \frac{B}{H}, \text{ but not greater than } 2.5$$

$B$  = Width of windlass measured parallel to the shaft axis,

$H$  = Overall height of windlass.

Where mooring winches are integral with the anchor windlass, they are to be considered as part of the windlass.

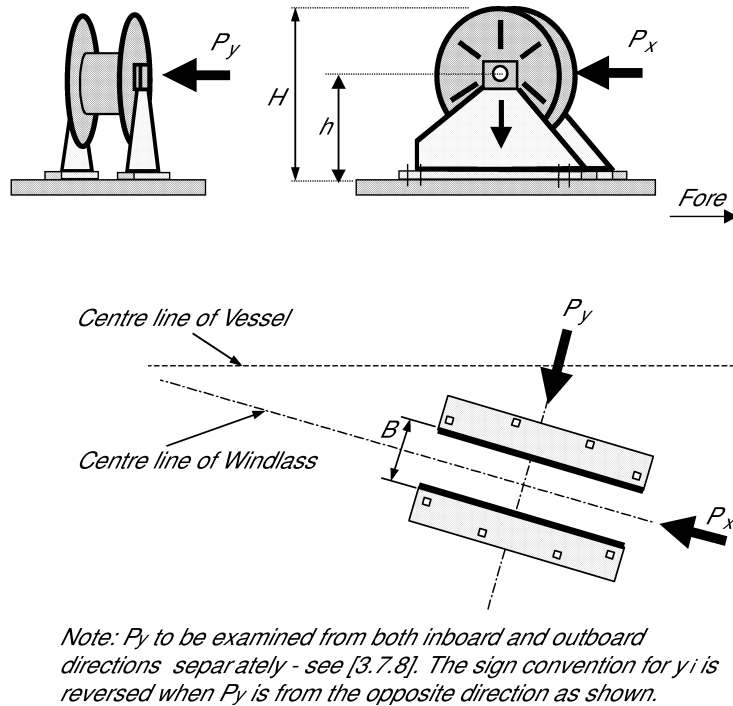

**Fig. 2**  
**Direction of forces and weight**

### 3.7.9 Forces in the securing devices of windlasses due to green sea loads

Forces in the bolts, chocks and stoppers securing the windlass to the deck are to be calculated by considering the green sea loads specified in [3.7.8].

The windlass is supported by  $N$  bolt groups, each containing one or more bolts (see also Fig 3).

The axial force  $R_i$  in bolt group (or bolt)  $i$ , positive in tension, is to be obtained, in kN, from the following formulae:

$$\begin{aligned} &— R_{xi} = P_x h x_i A_i / I_x \\ &— R_{yi} = P_y h y_i A_i / I_y \\ &— R_i = R_{xi} + R_{yi} - R_{si} \end{aligned}$$

where:

- $P_x$  = Force, in kN, acting normal to the shaft axis
- $P_y$  = Force, in kN, acting parallel to the shaft axis, either inboard or outboard, whichever gives the greater force in bolt group  $i$
- $h$  = Shaft height, in cm, above the windlass mounting
- $x_i, y_i$  =  $X$  and  $Y$  co-ordinates, in cm, of bolt group  $i$  from the centroid of all  $N$  bolt groups, positive in the direction opposite to that of the applied force
- $A_i$  = Cross-sectional area, in  $\text{cm}^2$ , of all bolts in group  $I$
- $I_x, I_y$  = Inertias, for  $N$  bolt groups, equal to:
 
$$I_x = \sum A_i x_i^2$$

$$I_y = \sum A_i y_i^2$$

$R_{si}$  = Static reaction force, in kN, at bolt group  $i$ , due to weight of windlass.

Shear forces  $F_{xi}$ ,  $F_{yi}$  applied to the bolt group  $i$ , and the resultant combined force  $F_i$  are to be obtained, in kN, from the following formulae:

$$\begin{aligned} &— F_{xi} = (P_x - \alpha g M) / N \\ &— F_{yi} = (P_y - \alpha g M) / N \\ &— F_i = (F_{xi}^2 + F_{yi}^2)^{0.5} \end{aligned}$$

where:

- $\alpha$  = Coefficient of friction, to be taken equal to 0.5



$M$  = Mass, in  $t$ , of windlass  
 $N$  = Number of bolt groups.

Axial tensile and compressive forces and lateral forces calculated according to these requirements are also to be considered in the design of the supporting structure.

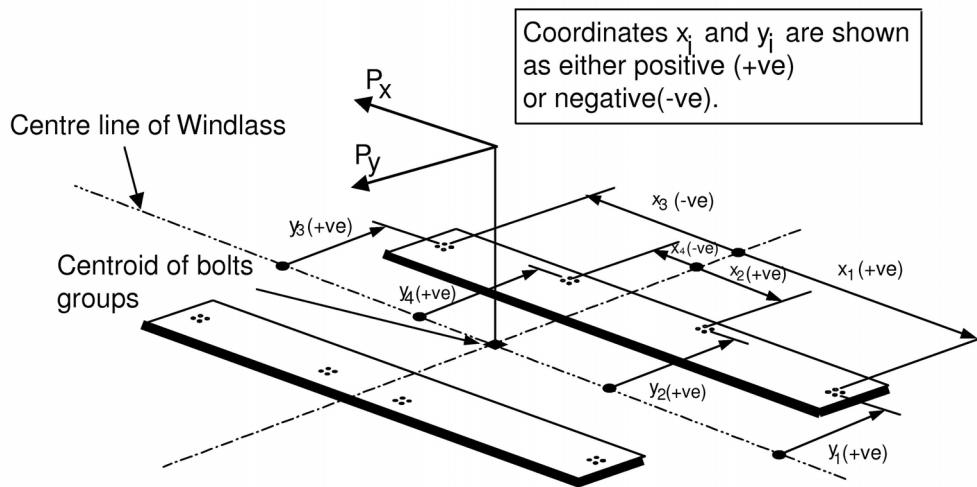

**Fig. 3**  
**Sign convention**

### 3.7.10 Strength criteria for windlass subject to anchor and chain loads

The stresses on the parts of the windlass, its frame and stopper are to be less than the yield stress of the material used.

For the calculation of the above stresses, special attention is to be paid to:

- stress concentrations in keyways and other stress raisers
- dynamic effects due to sudden starting or stopping of the prime mover or anchor chain
- calculation methods and approximation.

### 3.7.11 Strength criteria for securing devices of windlass

Tensile axial stresses in the individual bolts in each bolt group  $i$  are to be calculated according to the requirements specified in [3.7.9]. The horizontal forces  $F_{xi}$  and  $F_{yi}$ , to be calculated according to the requirements specified in [3.7.9], are normally to be reacted by shear chocks.

Where "fitted" bolts are designed to support these shear forces in one or both directions, the equivalent Von Mises stress  $\sigma$ , in  $N/mm^2$ , in the individual bolt is to comply with following formula:

$$\sigma \leq 0.5 \sigma_{BPL}$$

where  $\sigma_{BPL}$  is the stress in the bolt considered as being loaded by the proof load.

Where pourable resins are incorporated in the holding down arrangements, due account is to be taken in the calculations.

### 3.7.12 Connection with deck

The windlass, its frame and the stoppers are to be efficiently bedded to the deck.

## 3.8 Chain stoppers

### 3.8.1

A chain stopper is generally to be fitted between the windlass and the hawse pipe in order to relieve the windlass of the pull of the chain cable when the ship is at anchor. A chain stopper is to be capable of withstanding a pull of 80% of the breaking load of the chain cable. The deck at the chain stopper is to be suitably reinforced.

For the same purpose, a piece of chain cable may be used with a rigging screw capable of supporting the weight of the anchor when housed in the hawse pipe or a chain tensioner. Such arrangements are not to be considered as chain stoppers.

### **3.8.2**

Where the windlass is at a distance from the hawse pipes and no chain stoppers are fitted, suitable arrangements are to be provided to lead the chain cables to the windlass.

## **3.9 Chain locker**

### **3.9.1**

The capacity of the chain locker is to be adequate to stow all chain cable equipment and provide an easy direct lead to the windlass.

### **3.9.2**

Where two chains are used, the chain lockers are to be divided into two compartments, each capable of housing the full length of one line.

### **3.9.3**

The inboard ends of chain cables are to be secured to suitably reinforced attachments in the structure by means of end shackles, whether or not associated with attachment pieces.

Generally, such attachments are to be able to withstand a force not less than 15% of the breaking load of the chain cable.

In an emergency, the attachments are to be easily released from outside the chain locker.

### **3.9.4**

Where the chain locker is arranged aft of the collision bulkhead, its boundary bulkheads are to be watertight and a drainage system is to be provided.

## **3.10 Fairleads and bollards**

### **3.10.1**

Fairleads and bollards of suitable size and design are to be fitted for towing, mooring and warping operations.

# **Chapter 11**

## Construction and Testing

---

Section 1 Construction

Section 2 Welding

Section 3 Testing of Compartments



## SECTION 1 CONSTRUCTION

### 1 Structural details

#### 1.1 Cut-outs, plate edges

##### 1.1.1

The free edges (cut surfaces) of cut-outs, hatch corners, etc. are to be properly prepared and are to be free from notches. As a general rule, cutting draglines, etc. are not to be welded out, but are to be smoothly ground. All edges are to be broken or in cases of highly stressed parts, be rounded off.

Free edges on flame or machine cut plates or flanges are not to be sharp cornered and are to be finished off as laid down in above. This also applies to cutting drag lines, etc., in particular to the upper edge of shear stake and analogously to weld joints, changes in sectional areas or similar discontinuities.

##### 1.1.2

The hatch opening corners are to be machine cut.

#### 1.2 Cold forming

##### 1.2.1

For cold forming (bending, flanging, beading) of corrugated bulkhead the inside bending radius is to be not less than  $2t$  ( $t$  = as-built thickness).

In order to prevent cracking, flame cutting flash or sheering burrs are to be removed before cold forming. After cold forming all structural components and, in particular, the ends of bends (plate edges) are to be examined for cracks. Except in cases where edge cracks are negligible, all cracked components are to be rejected. Repair welding is not permissible.

#### 1.3 Assembly, alignment

##### 1.3.1

The use of excessive force is to be avoided during the assembly of individual structural components or during the erection of sections. As far as possible, major distortions of individual structural components are to be corrected before further assembly.

Structural members are to be aligned following the IACS recommendation No.47 provisions given in Table 1 or according to the requirements of a recognised fabrication standard that has been accepted by the Classification Society. In the case of critical components, control drillings are to be made where necessary, which are then to be welded up again on completion.

After completion of welding, straightening and aligning are to be carried out in such a manner that the material properties are not influenced significantly. In case of doubt, the Society may require a procedure test or a working test to be carried out.

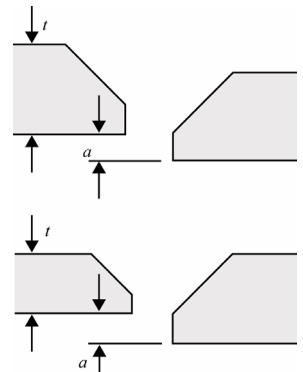
<i>Detail</i>	<i>Standard</i>	<i>Limit</i>	<i>Remarks</i>
Alignment of butt welds 		$a \leq 0.15t$ strength member $a \leq 0.2t$ other but maximum 4.0 mm	$t$ is the lesser plate thickness

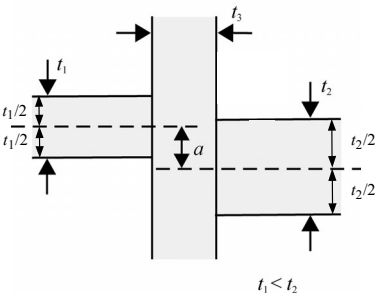
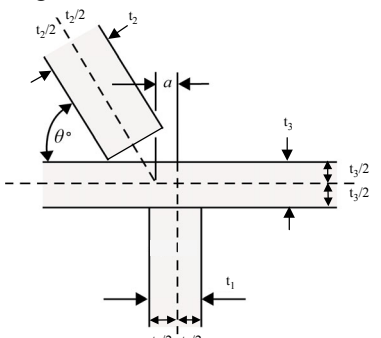
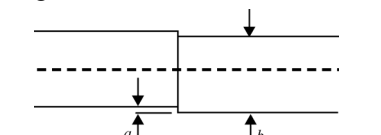
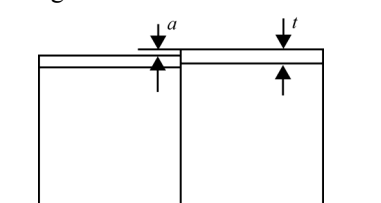
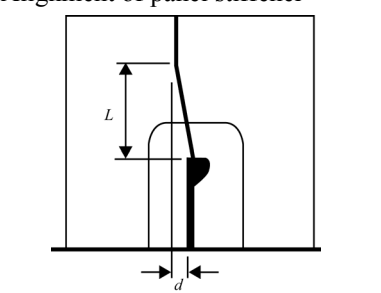
<b>Table 1 Alignment (<math>t</math>, <math>t_1</math>, and <math>t_2</math>: as-built thickness) (Continued)</b>			
<i>Detail</i>	<i>Standard</i>	<i>Limit</i>	<i>Remarks</i>
Alignment of fillet welds  <p style="text-align: center;"><math>t_1 &lt; t_2</math></p>		Strength member and higher stress member: $a \leq t_1/3$ Other: $a \leq t_1/2$	Alternatively, heel line can be used to check the alignment. Where $t_3$ is less than $t_1$ , then $t_3$ should be substituted for $t_1$ .
Alignment of fillet welds 		Strength member and higher stress member: $a \leq t_1/3$ Other: $a \leq t_1/2$	Alternatively, heel line can be used to check the alignment. Where $t_3$ is less than $t_1$ , then $t_3$ should be substitute for $t_1$ .
Alignment of face plates of T longitudinal 	Strength member $a \leq 0.04b$	$a = 8.0 \text{ mm}$	
Alignment of height of T-bar, L-angle bar or bulb 	Strength member $a \leq 0.15 t$ Other $a \leq 0.2 t$	$a = 3.0 \text{ mm}$	
Alignment of panel stiffener 	$d \leq L / 50$		
Note: “strength” means the following elements: strength deck, inner bottom, bottom, lower stool, lower part of transverse bulkhead, bilge hopper and side frames of single side bulk carriers.			

## **SECTION 2 WELDING**

### **1 General**

#### **1.1 Application**

##### **1.1.1**

The requirements of this Section apply to the preparation, execution and inspection of welded connections in hull structures.

##### **1.1.2**

Welding of hull parts is to be carried out by approved welders only.

##### **1.1.3**

Welding procedures and welding consumables approved for the types of connection and parent material in question are to be used.

##### **1.1.4**

Welding of connections is to be executed according to the approved plans.

##### **1.1.5**

The quality standard adopted by the shipyard is to be submitted to the Society and it applies to all welded connections unless otherwise specified on a case by case basis.

##### **1.1.6**

Completed weld joints are to be to the satisfaction of the attending Surveyor.

##### **1.1.7**

Non destructive examination (NDE) for weld is to be carried out at the position indicated by the test plan in order to ensure that the welds are free from cracks and internal harmful imperfections and defects.

#### **1.2 Welding consumables and procedures**

##### **1.2.1**

Welding consumables adopted are to be approved by the Society. The requirements for the approval of welding consumables are given in the Society's Rules or guide for welding.

##### **1.2.2**

The welding procedures adopted are to be approved by the Society. The requirements for the approval of welding procedures are given in the Society's Rules or guide for welding.

##### **1.2.3**

Suitable welding consumables are to be selected depending on the kind and grade of materials. The requirements of the selection of welding consumables are given in the Society's Rules or guide for welding.

#### **1.3 Welders and NDE operators**

##### **1.3.1 Welders**

Manual and semi-automatic welding is to be performed by welders certified by the Society as specified in the Society's Rules or guide for welding.

##### **1.3.2 Automatic welding operators**

Personnel manning automatic welding machines and equipment are to be competent and sufficiently trained and certified by the Society as specified in the Society's Rules or guide for welding.

### 1.3.3 NDE operator

NDE is to be carried out by qualified personnel certified by the Society or by recognized bodies in compliance with appropriate standards.

## 1.4 Documentation to be submitted

### 1.4.1

The welding application plan to be submitted for approval has to contain the necessary data relevant to the fabrication by welding of the structures, kinds of welding procedure applied, welding position, etc.

### 1.4.2

The NDE plan to be submitted for approval has to contain the necessary data relevant to the locations and number of examinations, welding procedure(s) applied, method of NDE applied, etc.

## 2 Types of welded connections

### 2.1 General

#### 2.1.1

The type of welded connections and the edge preparation are to be appropriate to the welding procedure adopted.

### 2.2 Butt welding

#### 2.2.1 General

Butt connections of plating are to be full penetration, welded on both sides except where special welding procedures approved by the Society is applied.

#### 2.2.2 Welding of plates with different thicknesses

In the case of welding of plates with a difference in as-built thickness equal to or greater than 4 mm, the thicker plate is normally to be tapered. The taper has to have a length of not less than 3 times the difference in as-built thickness.

#### 2.2.3 Edge preparation, root gap

Edge preparations and root gaps are to be in accordance with the adopted welding procedure and relevant bevel preparation.

### 2.3 Tee or cross joints

#### 2.3.1 General

The connections of primary supporting members and stiffener webs to plating as well as plating abutting on another plating, are to be made by fillet welding or deep penetration weld, as shown in Fig 1.

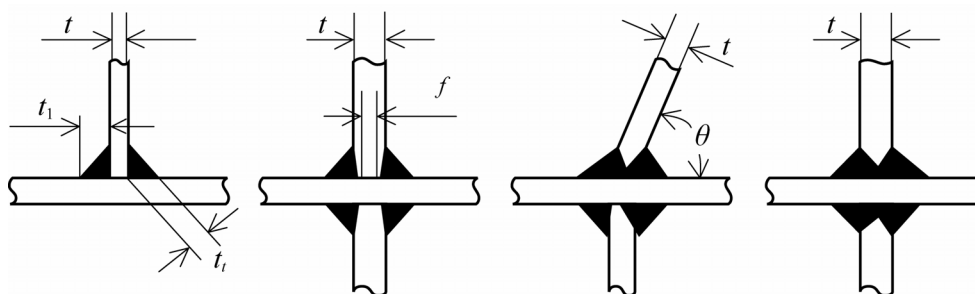

Fig. 1  
Tee or cross joints

- $t$  = As-built thickness of abutting plate, in mm  
 $f$  = Unwelded root face, in mm, taken as  $f \leq t/3$   
 $t_\ell$  = Leg length of the fillet weld, in mm



$t_t$  = Throat thickness, in mm.

## 2.4 Full penetration welds

### 2.4.1 Application

Full penetration welds are to be used in the following connections:

- rudder horns and shaft brackets to shell structure
- rudder side plating to rudder stock connection areas
- vertical corrugated bulkhead to inner bottom plating that are situated in the cargo area and arranged without transverse lower stool
- vertical corrugated bulkhead to top plating of transverse lower stool
- pillars to plating member, in case the stress acting on the pillar is tension (i.e. engine room, fore peak and deckhouses)
- edge reinforcement or pipe penetrations both to strength deck, sheer strake and bottom plating within  $0.6L$  amidships, when the dimension of the opening exceeds 300 mm
- abutting plate panels forming boundaries to sea below summer load waterline.

### 2.4.2

In case where shedder plates are fitted at the lower end of corrugated bulkhead, the shedder plates are to be welded to the corrugation and the top plate of the transverse lower stool by one side penetration welds or equivalent.

### 2.4.3

The transverse lower stool side plating is to be connected to the transverse lower stool top plating and the inner bottom plating by full penetration welds. Deep penetration welds may be accepted.

### 2.4.4

The supporting floors are to be connected to the inner bottom plating by full penetration welds. Deep penetration welds may be accepted.

### 2.4.5

Generally, adequate groove angle between 40 and 60 degrees and root opening is to be taken and if necessary back gouging for both side welding is required.

## 2.5 Deep penetration weld

### 2.5.1

Deep penetration weld is defined as Fig 2.

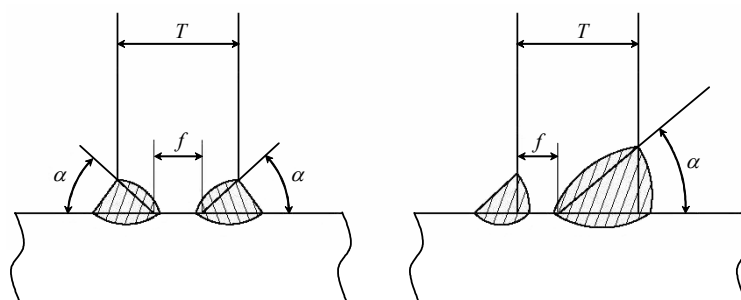

- Root face ( $f$ ) : 3 mm to  $T/3$  mm
- Groove angle ( $\alpha$ ) : 40° to 60°

Fig. 2  
Deep penetration weld

## 2.6 Fillet welds

### 2.6.1 Kinds and size of fillet welds and their applications

Kinds and size of fillet welds for as-built thickness of abutting plating up to 50 mm are classed into 5 categories as given in Table 1 and their application to hull construction is to be as required by Table 2.

In addition, for zones “a” and “b” of side frames as shown in Ch 3, Sec 6, Fig 19, the weld throats are to be respectively  $0.44t$  and  $0.4t$ , where  $t$  is as-built thickness of the thinner of two connected members.

Category	Kinds of fillet welds	As-built thickness of abutting plate, $t$ , in mm (1)	Leg length of fillet weld, in mm (2)	Length of fillet welds, in mm	Pitch, in mm
F0	Double continuous weld	$t$	$0.7t$	-	-
F1	Double continuous weld	$t \leq 10$	$0.5t + 1.0$	-	-
		$10 \leq t < 20$	$0.4t + 2.0$	-	-
		$20 \leq t$	$0.3t + 4.0$	-	-
F2	Double continuous weld	$t \leq 10$	$0.4t + 1.0$	-	-
		$10 \leq t < 20$	$0.3t + 2.0$	-	-
		$20 \leq t$	$0.2t + 4.0$	-	-
F3	Double continuous weld	$t \leq 10$	$0.3t + 1.0$	-	-
		$10 \leq t < 20$	$0.2t + 2.0$		
		$20 \leq t$	$0.1t + 4.0$		
F4	Intermittent weld	$t \leq 10$	$0.5t + 1.0$	75	300
		$10 \leq t < 20$	$0.4t + 2.0$		
		$20 \leq t$	$0.3t + 4.0$		

(1)  $t$  is as-built thickness of the abutting plate, in mm. In case of cross joint as specified in Fig 1,  $t$  is the thinner thickness of the continuous member and the abutting plate, to be considered independently for each abutting plate.

(2) Leg length of fillet welds is made fine adjustments corresponding to the corrosion addition  $t_C$  specified in Ch 3, Sec 3, Table 1 as follows:  
 + 1.0 mm for  $t_C > 5$   
 + 0.5 mm for  $5 \geq t_C > 4$   
 + 0.0 mm for  $4 \geq t_C > 3$   
 - 0.5 mm for  $t_C \leq 3$

(3) Leg length is rounded to the nearest half millimetre.

Hull area	Connection		Category	
	Of	To		
General, unless otherwise specified in the table (1)	Watertight plate	Boundary plating	F1	
	Brackets at ends of members		F1	
	Ordinary stiffener and collar plates	Deep tank bulkheads		F3
		Web of primary supporting members and collar plates		F2
	Web of ordinary stiffener	Plating (Except deep tank bulkhead)		F4
		Face plates of built-up stiffeners	At ends (15% of span)	F2
			Elsewhere	F4
	End of primary supporting members and ordinary stiffeners without brackets	Deck plate, shell plate, inner bottom plate, bulkhead plate		F0
End of primary supporting members and ordinary stiffeners with brackets	Deck plate, shell plate, inner bottom plate, bulkhead plate		F1	

Table 2 Application of fillet welds (Continued)					
Hull area	Connection			Category	
	Of	To			
Bottom and double bottom	Ordinary stiffener	Bottom and inner bottom plating		F3	
	Center girder	Shell plates in strengthened bottom forward		F1	
		Inner bottom plate and shell plate except the above		F2	
	Side girder including intercostal plate	Bottom and inner bottom plating		F3	
	Floor	Shell plates and inner bottom plates	At ends, on a length equal to two frame spaces		F2
		Center girder and side girders in way of hopper tanks		F2	
		Elsewhere		F3	
Bracket on center girder	Center girder, inner bottom and shell plates		F2		
Web stiffener	Floor and girder		F3		
Side and inner side in double side structure	Web of primary supporting members	Side plating, inner side plating and web of primary supporting members		F2	
Side frame of single side structure	Side frame and end bracket	Side shell plate		See Ch 3 Sec 6 Fig. 19	
	Tripping bracket	Side shell plate and side frame		F1	
Deck	Strength deck	$t \geq 13$	Side shell plating within 0.6L midship		Deep penetration
		$t < 13$	Elsewhere		F1
	Other deck	Side shell plating		F1	
		Ordinary stiffeners		F2	
	Ordinary stiffener and intercostal girder	Deck plating		F4	
	Hatch coamings	Deck plating	At corners of hatchways for 15% of the hatch length		F3
			Elsewhere		F2
Web stiffeners	Coaming webs		F4		
Bulkheads	Non-watertight bulkhead structure	Boundaries	Swash bulkheads	F1	
	Ordinary stiffener	Bulkhead plating	At ends (25% of span), where no end brackets are fitted	F3	
Primary supporting members <sup>(1)</sup>	Web plate	Shell plating, deck plating, inner bottom plating, bulkhead	At end (15% of span)	F1	
			Elsewhere	F2	
	Face plate	In tanks, and located within 0.125L from fore peak		F2	
		Face area exceeds 65 cm <sup>2</sup>		F2	
		Elsewhere		F3	
After peak	Internal members	Boundaries and each other		F2	
Seating	Girder and bracket	Bed plate	In way of main engine, thrust bearing, boiler bearers and main generator engines	F1	
		Girder plate	In way of main engine and thrust bearing	F1	
		Inner bottom plate and shell	In way of main engine and thrust bearing	F2	
Super-structure and deck houses <sup>(3)</sup>	External bulkhead	Deck		F1	
	Ordinary stiffeners	Side wall and deck plate	At end (15% of span)	F3	
			Elsewhere	F4 <sup>(2)</sup>	
	End section of ordinary stiffener and Primary supporting member	Without brackets	Side wall and web of primary supporting members		F1
With bracket		F2			
Pillar	Pillar	Heel and head		F1	

Hull area	Connection		Category
	Of	To	
Ventilator	Coaming	Deck	F1
Rudder	Rudder frame	Vertical frames forming main piece	F1
		Rudder plate	F3
		Rudder frames except above	F2

(1) For Hatch cover, weld sizes F1, F2 and F3 instead of F0, F1 and F2, respectively, are to be used.  
(2) Where the one side continuous welding is applied, the weld size F3 is to be applied.  
(3) The interior bulkheads are not included in this category. The welding of the interior bulkheads is to be subjected to the discretion of the Society.

### 2.6.2 Intermittent welds

Where double continuous fillet welds in lieu of intermittent welds are applied, leg length of fillet welds is to be of category F3.

### 2.6.3 Size of fillet weld for abutting plating with small angle

Where the angle between an abutting plate and the connected plate is not 90 degrees as shown in Fig 3, the size of fillet welds for the side of larger angle is to be increased in accordance with the following formula:

$$t'_\ell = t_\ell \frac{1}{\sqrt{2} \sin\left(\frac{\varphi}{2}\right)}$$

where:

$t_\ell$  = Leg length of the fillet weld, in mm, as defined in [2.3.1]

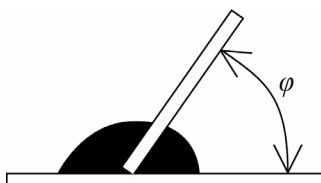

**Fig. 3**  
Connecting angle

### 2.6.4 Deep penetration welds

The leg length of fillet welds of deep penetration type may be reduced by 15% of that required in Table 1, depending on the welding procedure test.

## 2.7 Lap joint welds

### 2.7.1 General

Lap joint welds may be adopted in very specific cases subject to the approval of the Society. Lap joint welds may be adopted for the followings:

- peripheral connections of doublers
- internal structural elements subject to very low stresses.

### 2.7.2 Fillet welds

Lap joints are to have the fillet size of category F1.

## 2.8 Slot welds

### 2.8.1 General

Slot welds may be adopted in very specific cases subject to the approval of the Society. However, slot welds of doublers on the outer shell and strength deck are not permitted within 0.6L amidships.

## 2.8.2 Size of fillet welds

The slot welds are to have adequate shape to permit a thoroughly fused bead to be applied all around the bottom edge of the opening. The size of fillet welds is to be category F1 and spacing of slots is to be as determined by the Society on a case by case basis.

## 3 Connection details

### 3.1 Bilge keel connection

#### 3.1.1

The intermediate flat, through which the bilge keel is connected to the shell, according to Ch 3, Sec 6, [6.5.2], is to be welded to bilge plating and bilge keel.

#### 3.1.2

The butt welds of the intermediate flat and bilge keel are to be full penetration and shifted from the shell butts. The butt welds of the bilge plating and those of the intermediate flat are to be flush in way of crossing, respectively, with the intermediate flat and with the bilge keel.

#### 3.1.3

Along the longitudinal edges, the intermediate flat is to be continuously fillet welded with a throat thickness "a" of 0.3 times its thickness. At the ends of intermediate flat, the throat thickness "a" at the end faces is to be increased to 0.5 times the intermediate flat thickness but is to be less than the bilge plating thickness (see Fig 4).

The welded transition at the end faces of the doubling plates to the plating should form with the latter an angle of 45° or less.

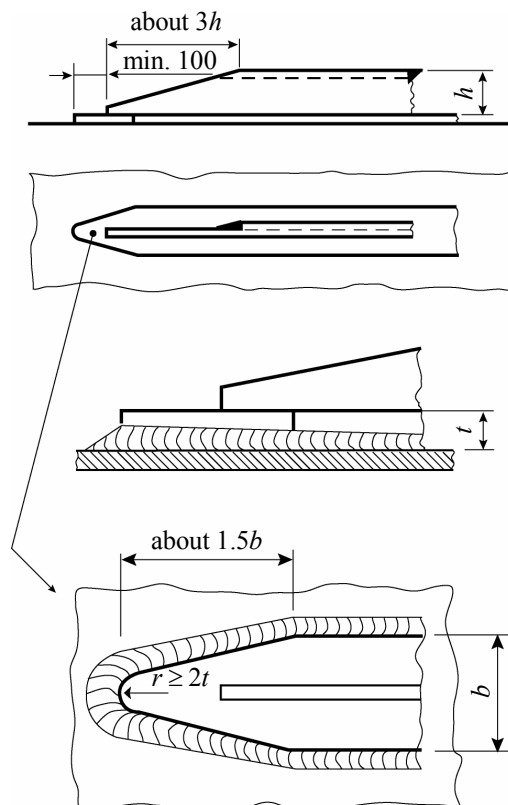

Fig. 4  
Bilge keel welding arrangement

## **SECTION 3**

### **TESTING OF COMPARTMENTS**

#### **1 General**

##### **1.1 Definitions**

###### **1.1.1 Shop primer**

Shop primer is a thin coating applied after surface preparations and prior to fabrication as a protection against corrosion during fabrication.

###### **1.1.2 Protective coating**

Protective coating is a final coating protecting the structure from corrosion.

###### **1.1.3 Structural testing**

Structural testing is a hydrostatic test carried out to demonstrate the tightness of the tanks and the structural adequacy of the design. Where practical limitations prevail and hydrostatic testing is not feasible (for example when it is difficult, in practice, to apply the required head at the top of tank), hydropneumatic testing may be carried out instead. When hydropneumatic testing is performed, the conditions should simulate, as far as practicable, the actual loading of the tank.

###### **1.1.4 Hydropneumatic testing**

Hydropneumatic testing is a combination of hydrostatic and air testing, consisting in filling the tank with water up to its top and applying an additional air pressure. The value of additional air pressure is at the discretion of the Society, but is to be at least as defined in [2.2].

###### **1.1.5 Leak testing**

Leak testing is an air or other medium test carried out to demonstrate the tightness of the structure.

###### **1.1.6 Hose testing**

Hose testing is carried out to demonstrate the tightness of structural items not subjected to hydrostatic or leak testing and to other compartments which contribute to the watertight integrity of the hull.

#### **1.2 Application**

##### **1.2.1**

The following requirements determine the testing conditions for:

- tanks, including independent tanks,
- watertight or weathertight structures.

##### **1.2.2**

The purpose of these tests is to check the tightness and/or the strength of structural elements at time of ship construction and on the occasion of major repairs.

##### **1.2.3**

Tests are to be carried out in the presence of the Surveyor at a stage sufficiently close to completion so that any subsequent work not impair the strength and tightness of the structure.

#### **2 Testing methods**

##### **2.1 Structural testing**

###### **2.1.1**

Structural testing may be carried out after application of the shop primer.

### 2.1.2

Structural testing may be carried out after the protective coating has been applied, provided that one of the following two conditions is satisfied:

- all the welds are completed and carefully inspected visually to the satisfaction of the Surveyor prior to the application of the protective coating,
- leak testing is carried out prior to the application of the protective coating.

### 2.1.3

In absence of leak testing, protective coating should be applied after the structural testing of:

- all erection welds, both manual and automatic,
- all manual fillet weld connections on tank boundaries and manual penetration welds.

## 2.2 Leak testing

### 2.2.1

Where leak testing is carried out, in accordance with Table 1, an air pressure of  $0.15 \cdot 10^5$  Pa is to be applied during the test.

### 2.2.2

Prior to inspection, it is recommended that the air pressure in the tank is raised to  $0.20 \cdot 10^5$  Pa and kept at this level for about 1 hour to reach a stabilized state, with a minimum number of personnel in the vicinity of the tank, and then lowered to the test pressure.

### 2.2.3

The Society may accept that the test is conducted after the pressure has reached a stabilized state at  $0.20 \cdot 10^5$  Pa, without lowering pressure, provided they are satisfied of the safety of the personnel involved in the test.

### 2.2.4

Welds are to be coated with an efficient indicating liquid.

### 2.2.5

A U-tube filled with water up to a height corresponding to the test pressure is to be fitted to avoid overpressure of the compartment tested and verify the test pressure. The U-tube should have a cross section larger than that of the pipe supplying air.

In addition, test pressure is also to be verified by means of one master pressure gauge. The Society may accept alternative means which are considered to equivalently reliable.

### 2.2.6

Leak testing is to be carried out, prior to the application of protective coating, on all fillet weld connections on tank boundaries, penetrations and erection welds on tank boundaries excepting welds may be automatic processes. Selected locations of automatic erection welds and pre-erection manual or automatic welds may be required to be similarly tested at the discretion of the Surveyor taking account of the quality control procedures operating in the shipyard. For other welds, leak testing may be carried out, after the protective coating has been applied, provided that these welds were carefully inspected visually to the satisfaction of the Surveyor.

### 2.2.7

Any other recognized method may be accepted to the satisfaction of the Surveyor.

## 2.3 Hose testing

### 2.3.1

When hose testing is required to verify the tightness of the structures, as defined in Table 1, the minimum pressure in the hose, at least equal to  $0.20 \cdot 10^5$  Pa, is to be applied at a maximum distance of 1.5 m. The nozzle diameter is not to be less than 12 mm.

## 2.4 Hydropneumatic testing

### 2.4.1

When hydropneumatic testing is performed, the same safety precautions as for leak testing are to be adopted.

## 2.5 Other testing methods

### 2.5.1

Other testing methods may be accepted, at the discretion of the Society, based upon equivalency considerations.

## 3 Testing requirements

### 3.1 General

#### 3.1.1

General testing requirements for testing are given in Table 1.

<i>Item number</i>	<i>Structural to be tested</i>	<i>Type of testing</i>	<i>Structural test pressure</i>	<i>Remarks</i>
1	Double bottom tanks	Structural testing (1)	The greater of the following: — head of water up to the top of overflow — head of water up to the bulkhead deck	Tank boundaries tested from at least one side
2	Double side tanks	Structural testing (1)	The greater of the following: — head of water up to the top of overflow — 2.4 m head of water above highest point of tank	Tank boundaries tested from at least one side
3	Tank bulkheads, deep tanks	Structural testing (1)	The greater of the following: (2) — head of water up to the top of overflow — 2.4 m head of water above highest point of tank — setting pressure of the safety relief valves, where relevant	Tank boundaries tested from at least one side
	Fuel oil tanks	Structural testing		
4	Ballast holds	Structural testing (1)	The greater of the following: — head of water up to the top of overflow — 0.90 m head of water above top of hatch	
5	Fore peak and after peak used as tank	Structural testing	The greater of the following: — head of water up to the top of overflow — 2.4 m head of water above highest point of tank	Tank of the after peak carried out after the stern tube has been fitted
	Fore peak not used as tank	Refer to SOLAS Ch. II-1 Reg.14		
	Aft peak not used as tank	Leak testing		
6	Cofferdams	Structural testing (3)	The greater of the following: — head of water up to the top of overflow — 2.4 m head of water above highest point of tank	
7	Watertight bulkheads	Refer to SOLAS Ch. II-1 Reg.14 (4)		
8	Watertight doors below freeboard or bulkhead deck	Refer to SOLAS Ch. II-1 Reg.18		
9	Double plate rudder	Leak testing		
10	Shaft tunnel clear of deep tanks	Hose testing		
11	Shell doors	Hose testing		



12	Watertight hatchcovers of tanks	Hose testing		
13	Watertight hatchcovers and closing appliances	Hose testing		
14	Chain locker, located aft of collision bulkhead	Structural testing	Head of water up to the top	
15	Independent tanks	Structural testing	Head of water up to the top of overflow, but not less than 0.9 m	
16	Ballast ducts	Structural testing	Ballast pump maximum pressure	
(1)	Leak or hydropneumatic testing may be accepted under the conditions specified in [2.2], provided that at least one tank for each type is structurally tested, to be selected in connection with the approval of the design. In general, structural testing need not be repeated for subsequent vessels of series of identical newbuildings. This relaxation does not apply to cargo space boundaries in tankers and combination carriers and tanks for segregated cargoes or pollutants. If the structural test reveals weakness or severe faults not detected by the leak test, all tanks are to be structurally tested.			
(2)	Where applicable, the highest point of tank is to be measured to the deck and excluding hatches. In holds for liquid cargo or ballast with large hatch covers, the highest point of tanks is to be taken at the top of hatch.			
(3)	Leak or hydropneumatic testing may be accepted under the conditions specified in [2.2] when, at the Society discretion, the latter is considered significant also in relation to the construction techniques and the welding procedures adopted.			
(4)	When hose test cannot be performed without damaging possible outfitting (machinery, cables, switchboards, insulation, etc.) already installed, it may be replaced, at the Society discretion, by a careful visual inspection of all the crossings and weld joints; where necessary, dye penetrant test or ultrasonic test may be required.			



# Chapter 12

## Additional Class Notations

---

### Section 1 **GRAB** Additional Class Notation



## SECTION 1 GRAB ADDITIONAL CLASS NOTATION

### Symbols

For symbols not defined in this Section, refer to Ch 1, Sec 4.

$M_{GR}$  = Mass of unladen grab, in tons  
 $s$  = Spacing, in m, of ordinary stiffeners, measured at mid-span

### 1 Basic concepts

#### 1.1 Application

##### 1.1.1

The additional class notation **GRAB [X]** is assigned, in accordance with Ch 1, Sec 1, [3.2], to ships with holds designed for loading/unloading by grabs having a maximum specific weight up to [X] tons, in compliance with the requirements of this Section.

##### 1.1.2

It is to be noted that this additional class notation does not negate the use of heavier grabs, but the owner and operators are to be made aware of the increased risk of local damage and possible early renewal of inner bottom plating if heavier grabs are used regularly or occasionally to discharge cargo.

### 2 Scantlings

#### 2.1 Plating

##### 2.1.1

The net thickness of plating of inner bottom, hopper tank sloping plate, transverse lower stool, transverse bulkhead plating and inner hull up to a height of 3.0m above the lowest point of the inner bottom, excluding bilge wells, is to be taken as the greater of the following values:

- $t$ , as obtained according to requirements in Ch 6 and Ch 7
- $t_{GR}$ , as defined in 2.1.2 and 2.1.3.

##### 2.1.2

The net thickness  $t_{GR}$ , in mm, of the inner bottom plating is to be obtained from the following formula:

$$t_{GR} = 0.28(M_{GR} + 50)\sqrt{sk}$$

##### 2.1.3

The net thickness  $t_{GR}$ , in mm, of hopper tank sloping plate, transverse lower stool, transverse bulkhead plating and inner hull up to a height of 3.0m above the lowest point of the inner bottom, excluding bilge wells, is to be obtained from the following formula:

$$t_{GR} = 0.28(M_{GR} + 42)\sqrt{sk}$$



# **Chapter 13**

## **Ships in Operation, Renewal Criteria**

---

Section 1 Maintenance of Class

Section 2 Thickness Measurements and Acceptance Criteria





## **SECTION 1 MAINTENANCE OF CLASS**

### **1 General**

#### **1.1 Application**

##### **1.1.1**

The survey requirements for the maintenance of class of bulk carriers are given in UR Z10.2 for single side skin bulk carriers and UR Z10.5 for double side skin bulk carriers.

Thickness measurements are a major part of surveys to be carried out for the maintenance of class, and the analysis of these measurements is a prominent factor in the determination and extent of the repairs and renewals of the ship's structure.

##### **1.1.2**

This Chapter is intended to provide Owners, companies performing thickness measurements and Society's Surveyors with a uniform procedure in order to fulfill rule requirements for thickness measurements. In particular, it will enable all the above-mentioned parties to carry out:

- the planning and preparation
- the determination of extent and location
- the analysis

of the thickness measurements.

##### **1.1.3**

This Chapter also takes into account specific requirements for thickness measurements relevant to close-up surveys within the scope of the Enhanced Survey Program (ESP) of single side skin bulk carriers and double side skin bulk carriers.

#### **1.2 Definitions**

##### **1.2.1 Local corrosion**

Local corrosion is pitting corrosion, grooving, edge corrosion, necking effect or other corrosions of very local aspect.

##### **1.2.2 Substantial corrosion**

Substantial corrosion is an extent of corrosion such that assessment of the corrosion pattern indicates a gauged (or measured) thickness between  $t_{renewal}$  and  $t_{renewal} + t_{reserve}$ .

## SECTION 2 THICKNESS MEASUREMENTS AND ACCEPTANCE CRITERIA

### Symbols

For symbols not defined in this Section, refer to Ch 1, Sec 4.

$t_{renewal}$	= Renewal thickness; Minimum allowable thickness, in mm, below which renewal of structural members is to be carried out $t_{renewal} = t_{as\ built} - t_C - t_{voluntary\ addition}$ .
$t_{reserve}$	= Reserve thickness; Thickness, in mm, to account for anticipated thickness diminution that may occur during a survey interval of 2.5 year. ( $t_{reserve} = 0.5$ mm)
$t_C$	= Corrosion addition, in mm, defined in Ch 3, Sec 3
$t_{as\ built}$	= As built thickness, in mm, including $t_{voluntary\ addition}$ , if any
$t_{voluntary\ addition}$	= Voluntary thickness addition; Thickness, in mm, voluntarily added as the Owner's extra margin for corrosion wastage in addition to $t_C$
$t_{gauged}$	= Gauged thickness, in mm, on one item, i.e average thickness on one item using the various measurements taken on this same item during periodical ship's in service surveys.

## 1 Application

### 1.1 General

#### 1.1.1

This section provides the following information:

- references to rule requirements and some additional information on the extent of the thickness measurements to be performed during surveys (see [2.1] and [2.2])
- locations of the measurements for the main parts of the ship (see [2.3])
- how to apply the acceptance criteria (see [3]).

Tables are also given to detail the above items. The sketches are given as an example to illustrate the requirements.

## 2 Rule requirements for the extent of measurements and the determination of locations

### 2.1 General

#### 2.1.1

For the maintenance of class, thickness measurements are required during intermediate and class renewal surveys and may be required during annual surveys.

Table 1 gives the references to the minimum requirements for thickness measurements related to the different types of surveys.

<b>Table 1 References to rule requirements related to thickness measurements</b>		
<i>Class renewal survey</i>	<i>Intermediate survey</i>	<i>Annual survey</i>
<p><b>Outside the cargo length area:</b> UR Z7:</p> <ul style="list-style-type: none"> <li>— systematic measurements and suspect areas.</li> <li>— where substantial corrosion is found, the extent of thickness measurements may be increased to the Surveyor's satisfaction.</li> </ul>	<p><b>Outside the cargo length area:</b> UR Z7:</p> <ul style="list-style-type: none"> <li>— thickness measurements to be taken if deemed necessary by the Surveyor.</li> <li>— where substantial corrosion is found, the extent of thickness measurements may be increased to the Surveyor's satisfaction.</li> </ul>	<p><b>Outside the cargo length area:</b> UR Z7:</p> <ul style="list-style-type: none"> <li>— areas of substantial corrosion identified at previous class renewal or intermediate surveys;</li> <li>— where substantial corrosion is found, the extent of thickness measurements may be increased to the Surveyor's satisfaction.</li> </ul>
<p><b>Within the cargo length area:</b></p> <p>a) single side skin bulk carriers: UR Z10.2:</p> <ul style="list-style-type: none"> <li>— planning and general requirements</li> <li>— measurements of elements subjected to close-up survey</li> <li>— extent of systematic thickness measurements</li> <li>— according to the different locations, where substantial corrosion is found</li> </ul> <p>b) double side skin bulk carriers: UR Z10.5:</p> <ul style="list-style-type: none"> <li>— planning and general requirements</li> <li>— measurements of elements subjected to close-up survey</li> <li>— extent of systematic thickness measurements</li> <li>— according to the different locations, where substantial corrosion is found</li> </ul>	<p><b>Within the cargo length area:</b></p> <p>a) single side skin bulk carriers: UR Z10.2:</p> <p><i>Ships 10 years of age or less:</i></p> <ul style="list-style-type: none"> <li>— for cargo holds</li> <li>— for salt ballast tanks</li> <li>— according to the different locations, where substantial corrosion is found</li> </ul> <p>Ships over 10 years of age:</p> <ul style="list-style-type: none"> <li>— see references given for class renewal survey</li> <li>— according to the different locations, where substantial corrosion is found</li> </ul> <p>b) double side skin bulk carriers: UR Z10.5</p> <p><i>Ships 10 years of age or less:</i></p> <ul style="list-style-type: none"> <li>— for cargo holds</li> <li>— for salt ballast tanks</li> <li>— according to the different locations, where substantial corrosion is found</li> </ul> <p><i>Ships over 10 years of age:</i></p> <ul style="list-style-type: none"> <li>— see references given for class renewal survey</li> <li>— according to the different locations, where substantial corrosion is found</li> </ul>	<p><b>Within the cargo length area:</b></p> <p>a) single side skin bulk carriers: UR Z10.2:</p> <ul style="list-style-type: none"> <li>— for cargo holds and when deemed necessary by the Surveyor</li> <li>— for salt ballast tanks and when deemed necessary by the Surveyor</li> <li>— according to the different locations, where substantial corrosion is found</li> </ul> <p>b) double side skin bulk carriers: UR Z10.5:</p> <ul style="list-style-type: none"> <li>— for cargo holds and when deemed necessary by the Surveyor</li> <li>— for salt ballast tanks and when deemed necessary by the Surveyor</li> <li>— according to the different locations, where substantial corrosion is found</li> </ul>

## 2.2 Class renewal survey

### 2.2.1

The thickness measurements required by the Rules consist of:

- systematic thickness measurements in order to assess the global and local strength of the ship
- thickness measurements as indicated in the program of close-up survey
- measurements of elements considered as suspect areas
- additional measurements on areas determined as affected by substantial corrosion.

### 2.2.2

For the determination of close-up surveys and relevant thickness measurements as well as the areas considered as suspect areas, reference is to be made to the relevant Sections of the following IACS Unified Requirements:

- for the hull structure and piping systems in way of cargo holds, cofferdams, pipe tunnels, void spaces, fuel oil tanks within the cargo length area and all ballast tanks:
  - UR Z10.2 "Hull surveys of single skin bulk carriers"
  - UR Z10.5 "Hull surveys of double skin bulk carriers"

— for the remainder of the ship outside the cargo length area:

— UR Z7.

## **2.3 Number and locations of measurements**

### **2.3.1 Number of measurements**

Considering the extent of thickness measurements as required by the Rules and indicated in [2.1] and [2.2], the locations of the points to be measured are given for the most important items of the structure.

### **2.3.2 Locations of measurements**

Table 2 provides explanations and/or interpretations for the application of those requirements indicated in the Rules which refer to both systematic thickness measurements related to the calculation of global hull girder strength and specific measurements connected to close-up surveys.

Fig 1 to Fig 5 are provided to facilitate the explanations and/or interpretations given in Table 2, to show typical arrangements of single side skin bulk carriers and double side skin bulk carriers.

<b>Table 2 Interpretations of rule requirements for the locations and number of points to be measured</b>		
<i>Item</i>	<i>Interpretation</i>	<i>Figure reference</i>
Selected plates on deck, tank top, bottom, double bottom and wind-and-water area	«Selected» means at least a single point on one out of three plates, to be chosen on representative areas of average corrosion	
All deck, tank top and bottom plates and wind-and-water strakes	At least two points on each plate to be taken either at each 1/4 extremity of plate or at representative areas of average corrosion	
Transverse section	<p><i>Single side skin bulk carrier:</i> A transverse section includes all longitudinal members such as plating, longitudinals and girders at the deck, side, bottom; inner bottom and hopper side plating, longitudinal bulkhead and bottom plating in top wing tanks.</p> <p><i>Double side skin bulk carrier:</i> A transverse section includes all longitudinal members such as plating, longitudinals and girders at the deck, sides, bottom, inner bottom, hopper sides, inner sides and top wing inner sides.</p>	Fig 1 for single and double side skin bulk carriers
Cargo hold hatch covers and coamings		Fig 2
Selected internal structure such as floors and longitudinals, transverse frames, web frames, deck beams, girders	The internal structural items to be measured in each space internally surveyed are to be at least 10% outside the cargo length area	
Transverse section of deck plating outside line of cargo hatch openings	Two single points on each deck plate (to be taken either at each 1/4 extremity of plate or at representative areas of average corrosion) between the ship sides and hatch coamings in the transverse section concerned	
Selected areas of all deck plating inside line of hatch openings	«Selected» means at least a single point on one out of three plates, to be chosen on representative areas of average corrosion «All deck plating» means at least two points on each plate to be taken either at each 1/4 extremity of plate or at representative areas of average corrosion	Extent of areas is shown in UR Z10.2 for single side skin bulk carriers and UR Z10.5 for double side skin bulk carriers
Selected side shell frames in cargo holds for single side skin bulk carriers	25% of frames: one out of four frames should preferably be chosen throughout the cargo hold length on each side «Selected frames» means at least 3 frames on each side of cargo holds	Extent of areas is shown in UR Z10.2 for single side skin bulk carriers. Locations of points are given in Fig 3 for single side skin bulk carriers
Transverse frame in double skin tank		Fig 1
Transverse bulkheads in cargo holds	Includes bulkhead plating, stiffeners and girders, including internal structure of upper and lower stools, where fitted. Two selected bulkheads: one is to be the bulkhead between the two foremost cargo holds and the second may be chosen in other positions	Areas of measurements are shown in UR Z10.2 for single side skin bulk carriers and UR Z10.5 for double side skin bulk carriers. Locations of points are given in Fig 4.
One transverse bulkhead in each cargo hold	This means that the close-up survey and related thickness measurements are to be performed on one side of the bulkhead; the side is to be chosen based on the outcome of the overall survey of both sides. In the event of doubt, the Surveyor may also require (possibly partial) close-up survey on the other side	Areas of measurements are shown in UR Z10.2 for single side skin bulk carriers and UR Z10.5 for double side skin bulk carriers. Locations of points are given in Fig 4.
Transverse bulkheads in one topside/side ballast tank	The ballast tank is to be chosen based on the history of ballasting among those prone to have the most severe conditions	Locations of points are given in Fig 5

Table 2 Interpretations of rule requirements for the locations and number of points to be measured		
Transverse webs in ballast tanks	One of the representative tanks of each type (i.e. topside or hopper or side tank) is to be chosen in the forward part	Extent of areas is shown in UR Z10.2 for single side skin bulk carriers and in UR Z10.5 for double side skin bulk carriers. Locations of points are given in Fig 3.

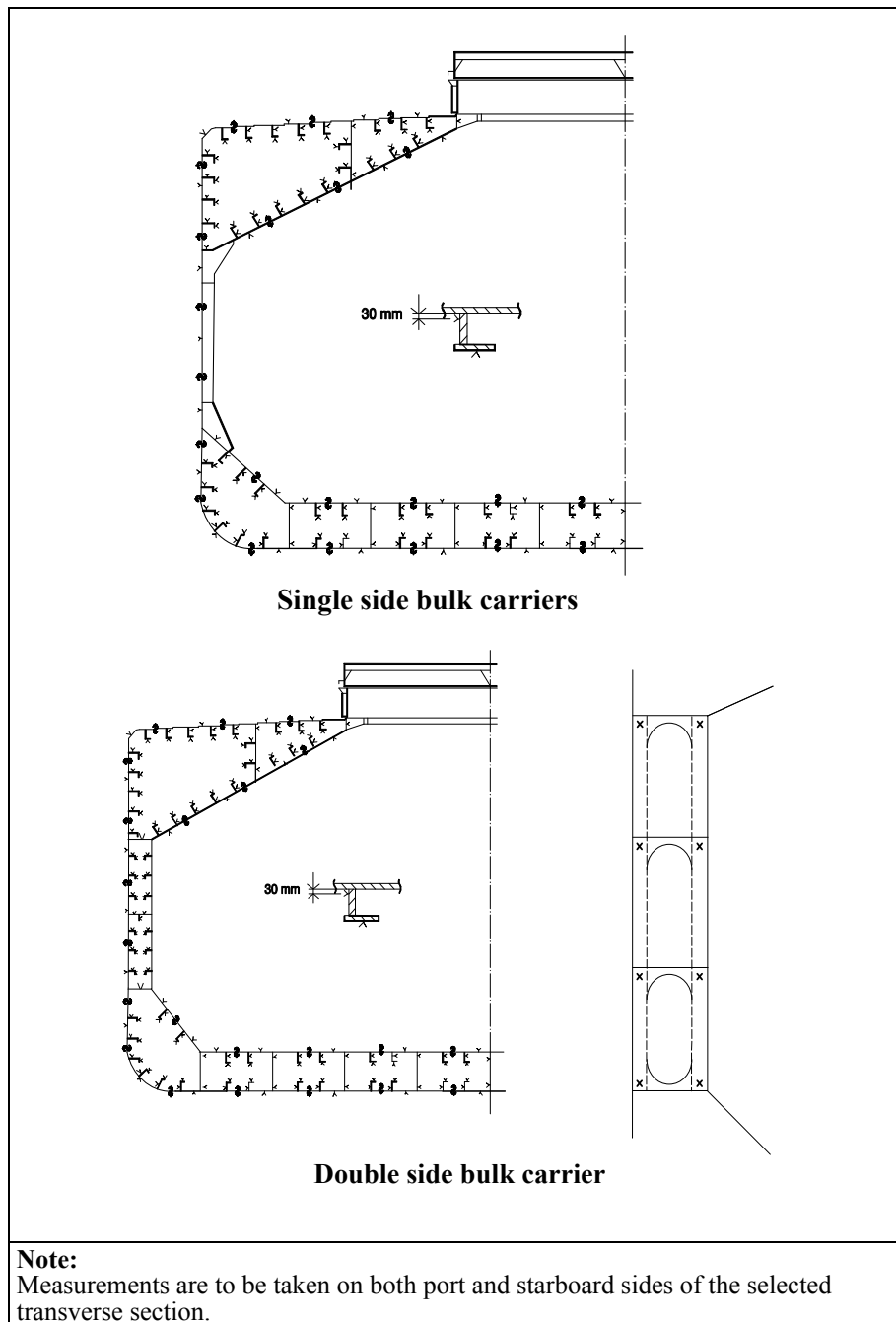

**Fig. 1**  
**Transverse section of bulk carrier**

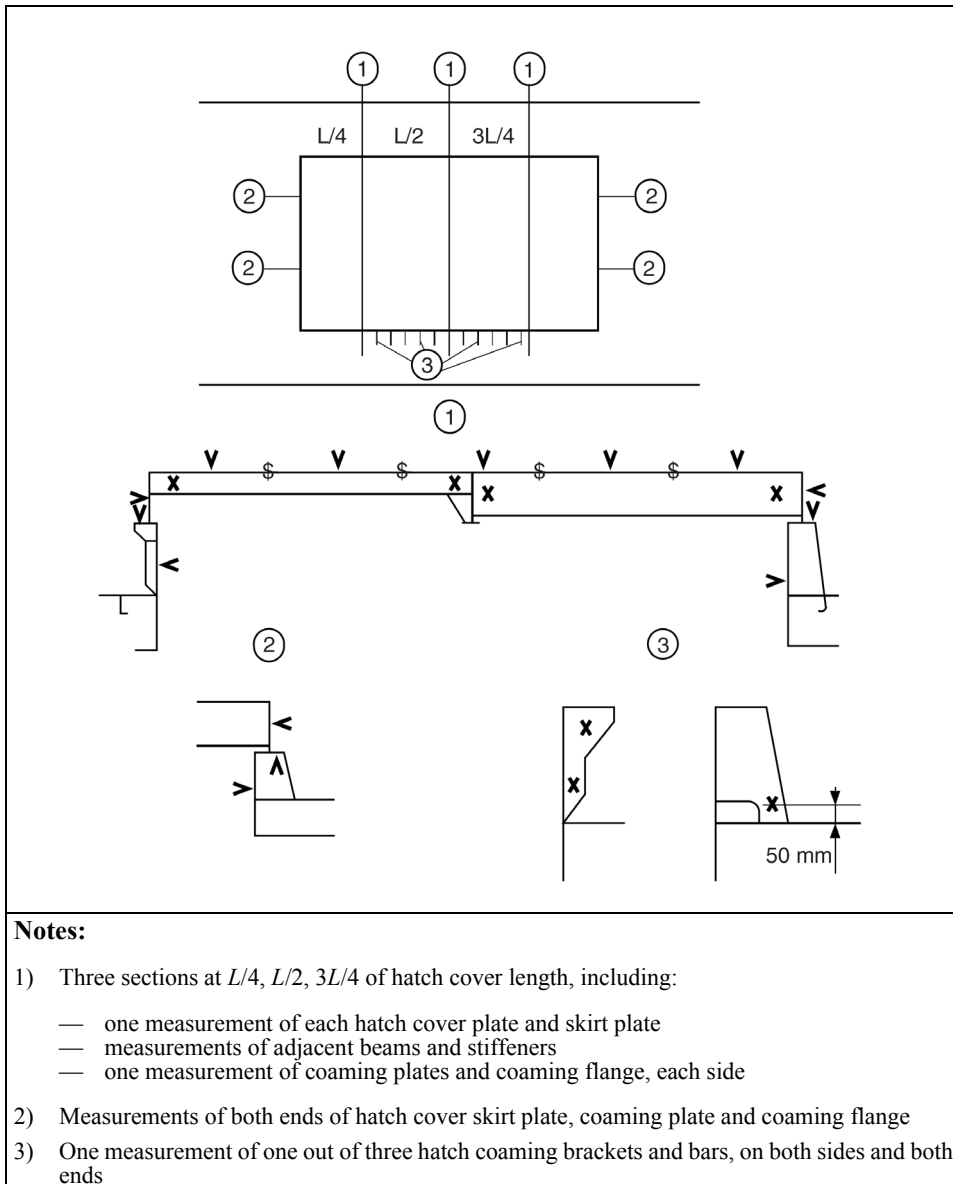

**Fig. 2**  
**Locations of measurements on hatch covers and coamings**

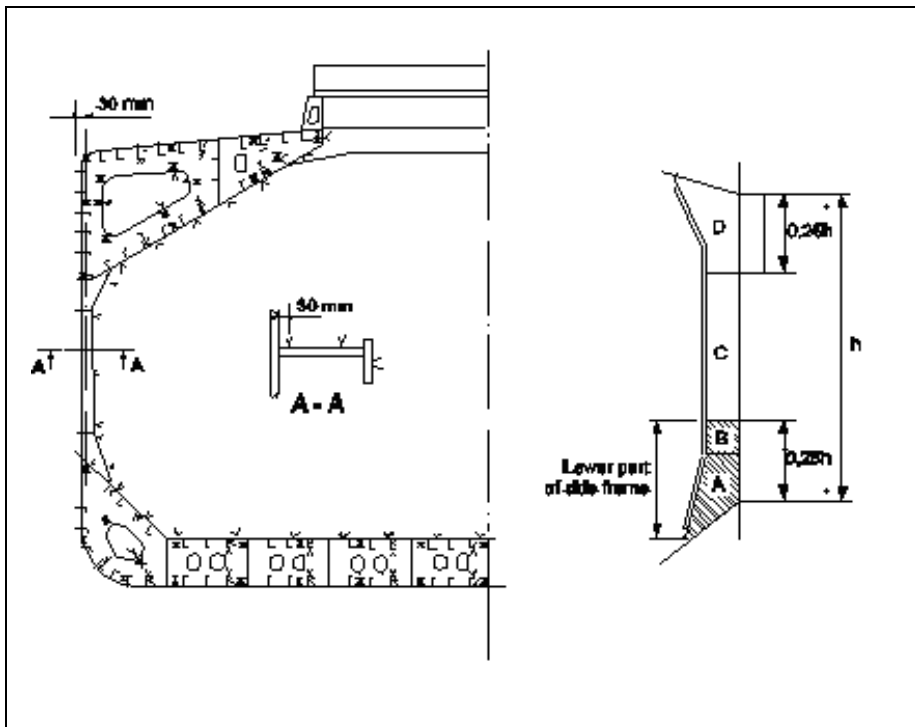

**Note:**

The gauging pattern for web plating is to be a three point pattern for zones A, C and D, and a two point pattern for zone B (see figure). The gauging report is to reflect the average reading. The average reading is to be compared with the allowable thickness. If the web plating has general corrosion then this pattern is to be expanded to a five point pattern.

**Fig. 3**

**Locations of measurements on structural members in cargo holds and ballast tanks of single side skin bulk carriers**



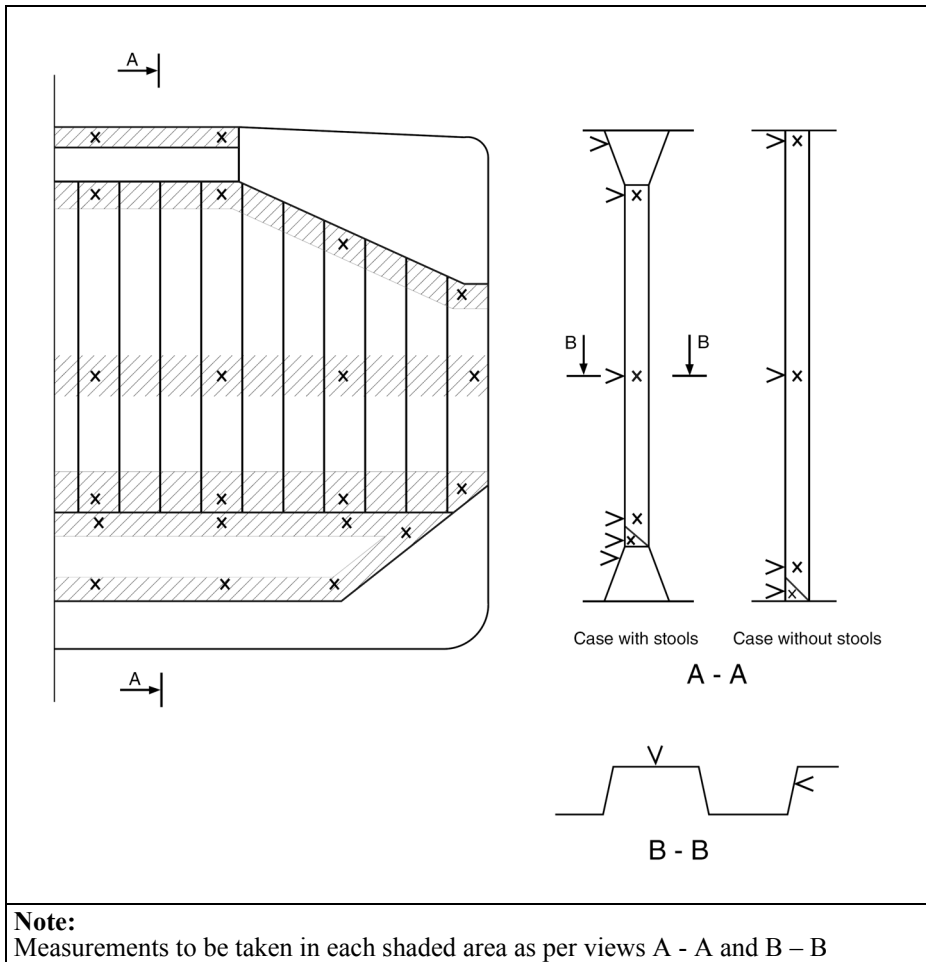

**Fig. 4**

## Locations of measurements on cargo hold transverse bulkheads

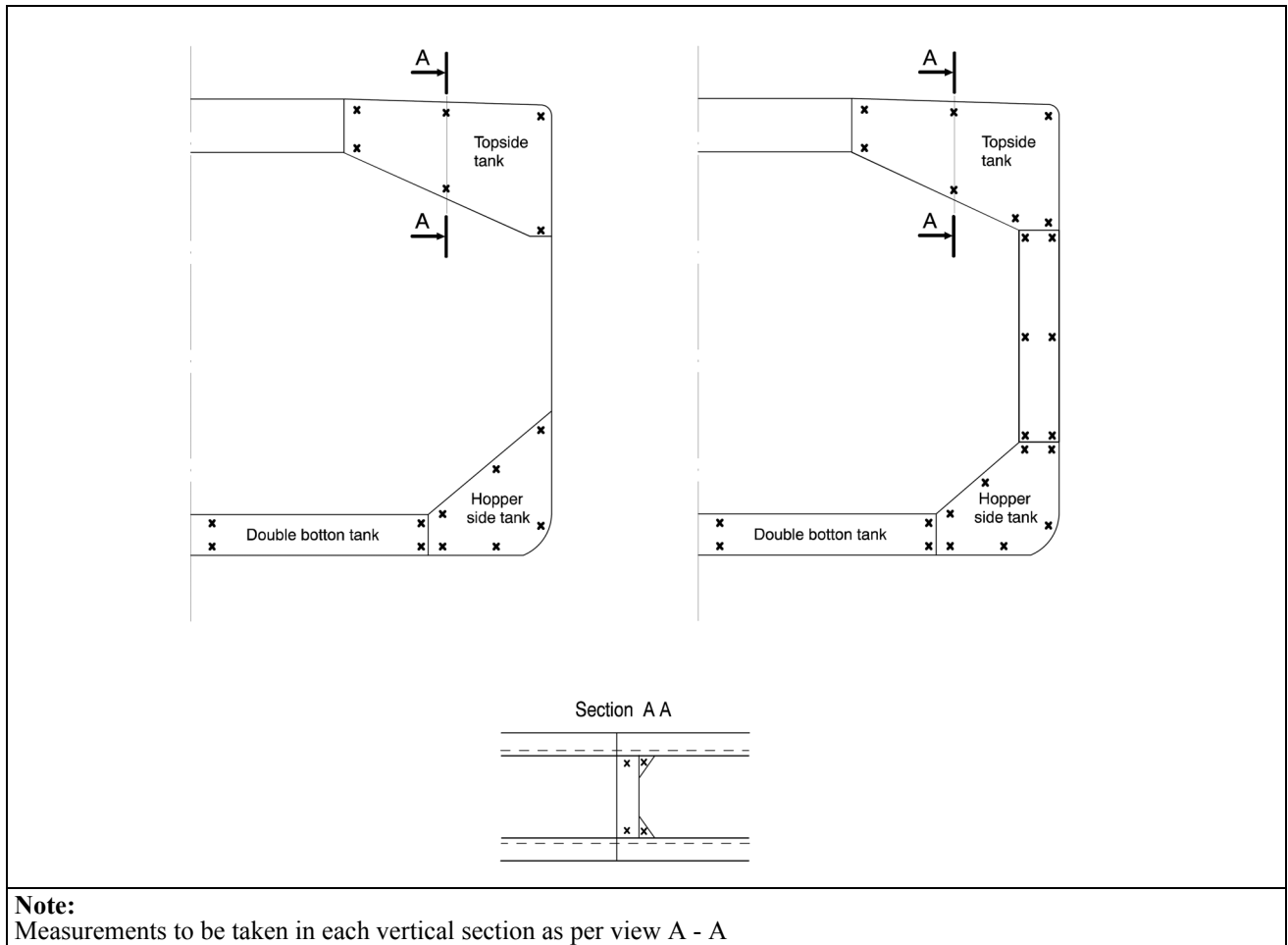

**Fig. 5**  
**Locations of measurements on transverse bulkheads of topside, hopper, double hull and double bottom tanks**

## 3 Acceptance Criteria

### 3.1 Definitions

#### 3.1.1 Deck zone

The deck zone includes all the following items contributing to the hull girder strength above the horizontal strake of the topside tank or above the level corresponding to  $0.9D$  above the base line if there is no topside tank:

- strength deck plating
- deck stringer
- sheer strake
- side shell plating
- top side tank sloped plating, including horizontal and vertical strakes
- longitudinal stiffeners connected to the above mentioned platings.

#### 3.1.2 Bottom zone

The bottom zone includes the following items contributing to the hull girder strength up to the upper level of the hopper sloping plating or up to the inner bottom plating if there is no hopper tank:

- keel plate
- bottom plating
- bilge plate

- bottom girders
- inner bottom plating
- hopper tank sloping plating
- side shell plating
- longitudinal stiffeners connected to the above mentioned platings.

### 3.1.3 Neutral axis zone

The neutral axis zone includes the plating only of the items between the deck zone and the bottom zone, as for example:

- side shell plating
- inner hull plating, if any

## 3.2 Local strength criteria

### 3.2.1 Items for the local strength criteria

The items to be considered for the local strength criteria are those of the deck zone, the bottom zone and the neutral axis zone, as defined in [3.1], and the additional following items:

- hatch coaming plating
- hatch coaming brackets
- hatch cover top plating
- hatch cover skirt plating
- hatch cover stiffeners
- transverse bulkheads plating
- transverse bulkheads stiffener web
- transverse bulkheads stiffener flange
- side shell frames web
- side shell frames flange
- side shell frames brackets
- web of topside and hopper tank web frames
- flange of topside and hopper tank web frames
- floors plating and stiffeners
- forward and aft peak bulkheads plating
- forward and aft peak bulkheads stiffener web
- forward and aft peak bulkheads stiffener flange
- stringers and girders.

### 3.2.2 Renewal thickness for corrosion other than local corrosion

For each item, steel renewal is required when the gauged thickness  $t_{\text{gauged}}$  is less than the renewal thickness, as specified in the following formula:

$$t_{\text{gauged}} < t_{\text{renewal}},$$

Where the gauged thickness  $t_{\text{gauged}}$  is such as:

$$t_{\text{renewal}} < t_{\text{gauged}} < t_{\text{renewal}} + t_{\text{reserve}}$$

coating applied in accordance with the coating manufacturer's requirements or annual gauging may be adopted as an alternative to the steel renewal. The coating is to be maintained in good condition.

### 3.2.3 Renewal thickness for local corrosion

If pitting intensity in an area where coating is required, according to Ch 3, Sec 5, is higher than 15% (see Fig 6), thickness measurements are to be performed to check the extent of pitting corrosion. The 15% is based on pitting or grooving on only one side of a plate.

In cases where pitting is exceeding 15%, as defined above, an area of 300 mm or more, at the most pitted part of the plate, is to be cleaned to bare metal and the thickness is to be measured in way of the five deepest pits within the cleaned area. The least thickness measured in way of any of these pits is to be taken as the thickness to be recorded.

The minimum remaining thickness in pits, grooves or other local areas as defined in Ch 13, Sec 1, [1.2.1] is to be greater than:

- 75% of the as-built thickness, in the frame and end brackets webs and flanges
- 70% of the as-built thickness, in the side shell, hopper tank and topside tank plating attached to the each side frame, over a width up to 30 mm from each side of it,

without being greater than  $t_{renewal}$ .

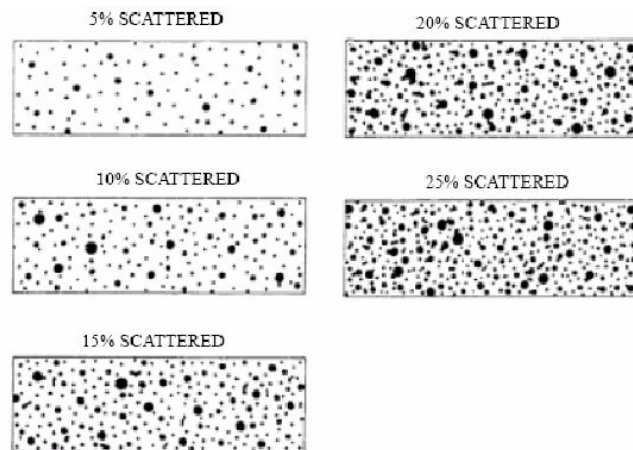

**Fig. 6**  
**Pitting intensity diagrams (from 5% to 25% intensity)**

### 3.3 Global strength criteria

#### 3.3.1 Items for the global strength criteria

The items to be considered for the global strength criteria are those of the deck zone, the bottom zone and the neutral axis zone, as defined in [3.1].

#### 3.3.2 Renewal thickness

The global strength criteria is defined by the assessment of the bottom zone, deck zone and neutral axis zone, as detailed below.

a) bottom zone and deck zone:

The current hull girder section modulus determined with the thickness measurements is not to be less than 90% of the section modulus calculated according to Ch 5, Sec 1 with the gross offered thicknesses.

Alternatively, the current sectional areas of the bottom zone and of the deck zone which are the sum of the gauged items area of the considered zones, are not to be less than 90% of the sectional area of the corresponding zones determined with the gross offered thicknesses.

b) neutral axis zone:

The current sectional area of the neutral axis zone, which is the sum of the gauged platings area of this zone, is not to be less than 85% of the gross offered sectional area of the neutral axis zone.

If the actual wastage of all items, of a given transverse section, which contribute to the hull girder strength is less than 10% for the deck and bottom zones and 15% for the neutral axis zone, the global strength criteria of this transverse section is automatically satisfied and its checking is no more required.