

Altistart 48 soft start - soft stop units

Catalogue
February

2002



Taming *energy*



Square D
Telemecanique

Schneider
 **Electric**
Building a New Electric World

Altistart 48 :

A new range for even better *performance...*

At *the heart of your applications,*

The new Altistart 48 soft start - soft stop unit gives you :

- High performance with its exclusive concept* for perfectly controlled starting and deceleration,
- Protection at all levels
- Easy integration in enclosures and control systems.

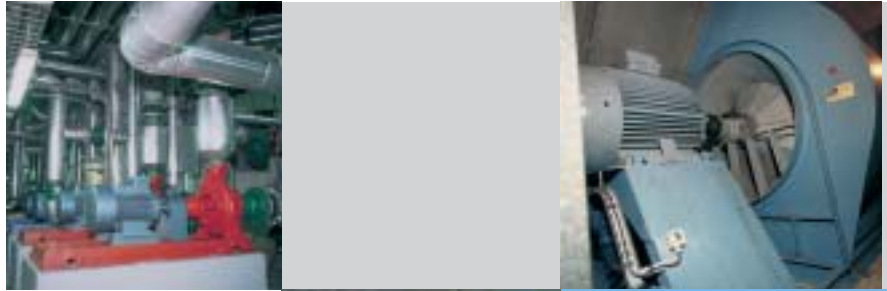

Two voltage ranges :

- 230 to 415V,
- 208 to 690V.

for 50 and 60 Hz line supplies

- Wide tolerance range for generators

for motor ratings from 4 to 1,200 kW

Standards and approvals

UL / CSA / IEC 60947-4-2
EMC: classes A and B
DNV (marine, off-shore)
C-TICK / GHOST / CCIB / NOM.

CE marking

in accordance with standard IEC 60947-4-2



* "TCS" patented system :
Torque Control System

... and so *simple*

Take the strain
off your motors,
your machines...
and your
operating
budgets...

The new generation of Altistart 48 starters has been designed to continually improve the operation of your machines :

- By reducing mechanical or hydraulic stress
- By reducing stress on the electrical distribution system (voltage peaks, overcurrent).
- By limiting energy loss and temperature rise, etc....

Wire it, connect... and start

Factory set, the Altistart 48 is operational immediately.

Customize your settings

Adjust the parameters of your motor using a simple, intuitive menu.



Let the Power Suite* software guide you

To prepare, store, print out configurations, compare files, etc....



Pocket PC



It is so simple to transfer data from the PC to the Pocket PC and vice versa.

* Software which is common to the Altivar range of variable speed drives.
Operating system available in 5 languages (English, French, German, Spanish and Italian).



High performance with the *exclusive TCS* concept*

***TCS patent :**
Torque Control System.

With **motor torque control**,
Altistart 48 provides perfect control of
the starting and stopping of machines.

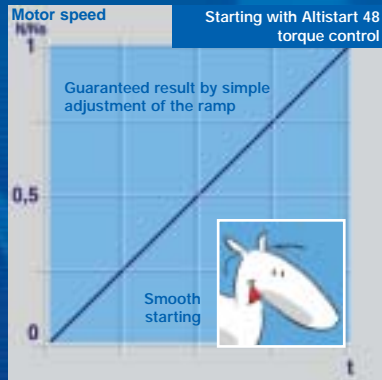

Control of the motor torque for the whole acceleration and deceleration period

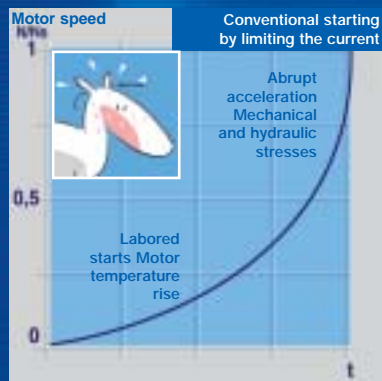

Motor torque not controlled :
non-linear acceleration
and deceleration

To limit stress on the drive chain.

Only with the Altistart 48 "TCS" system is it possible to :

- Maintain gradual acceleration up to nominal speed, even if there is a high starting torque
- Improve the lifetime of the belts and the mechanism

To reduce hydraulic transients.

Only with the Altistart 48 "TCS" system is it possible to:

- Very effectively reduce pressure surges and valve surges whatever the load conditions of the pump, while maintaining smooth deceleration, from full speed to stop.



With **conventional starting** by limiting the current :

- Labored starting causing motor temperature rise
- Abrupt ending of acceleration causing mechanical stress
- Difficult adjustment compromise

With **conventional starting** by limiting the current :

- Abrupt acceleration at the end of the ramp, causing sudden pressurization of the hydraulic lines.
- Uncontrolled deceleration which may lead to pressure surges...



Protection at all levels

motor :

- Thermal protection :
 - by calculation of the I^2t in accordance with IEC 60947-4-2.
 - by using PTC probes.
- Preheating function preventing condensation.
- Detection of phase failure.

machine :

- Underload and overload protection with adjustable thresholds and times
- Locked rotor
- Control of the direction of rotation



Strength
on lines subject to interference



Easy integration...

... in enclosures...



- **Simplified wiring** with through connection on all models
- Control of the starter bypass contactor at the end of starting with all protective functions maintained (thermal, underload, overload, etc...)



Control of the line contactor by the l'Altistart 48



Bypass contactor to prevent heat dissipation in the enclosure

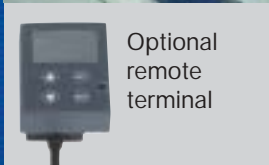

Optional remote terminal



... and in control systems

Functions to assist with the operation of your installations :

- Configuration of a second motor with different characteristics
- Display of electrical values (current, power, etc), load conditions and operating time.
- Maintenance of operator dialog due to a separate control circuit supply.
- A large number of configurable I/O (4 logic inputs, 2 logic outputs, 3 relay outputs and 1 analog output)
- Cascaded starting and deceleration of a number of motors



A wide range of communication functions for remote access to control, monitoring and adjustment functions :

- **Integrated Modbus.**
- Communication modules :
 - Fipio, Profibus DP, DeviceNet.
 - Ethernet TCP/IP for setting up Transparent Factory : open control systems platform based on Internet technology

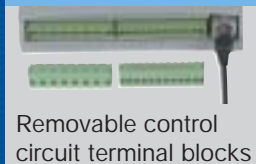

Removable control circuit terminal blocks



Transparent
FACTORY
Open for Business

Altistart 48 at the heart of your *applications*



With the *torque control*
and *functions* of the Altistart 48

Pumps

Standard*



- Better control of hydraulic transients :
 - Gradual pressurization of fluid in lines
 - Reduction of pressure surges and valve surges (in presence of line supply)
 - Elimination of damage to filters or spouts (irrigation) and premature wear of lines, etc
 - Less stress on pipes with the reduction of pressure-over pressure phenomena
- Independent adjustment of the load conditions.
- Protection against underload (running dry), loss or inversion of phases and in the event of a locked rotor.
- Automatic switching of the motor to freewheel mode on stopping, when the flow rate of the pump drops to a low level, to prevent overheating.

Fans and high inertia machines

(centrifuge, grinder, crusher, etc...)

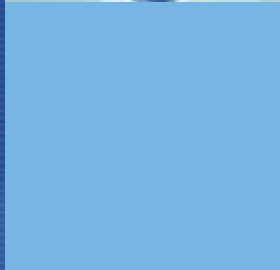

- Smooth starting, preventing stress on the drive chain and slipping of belts.
- "Smoke extraction" function
- Limitation of current and voltage drops on starting.
- Catching on the fly of a fan rotating in reverse.
- Detection of overload caused by clogging or underload (broken fan motor transmission)
- Braking torque on stopping.

Standard* or severe* (>30s)



Compressors

Standard* or severe* (>30s)

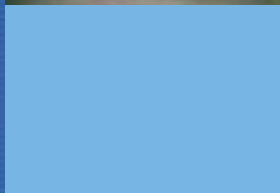

- Elimination of slipping of belts.
- Reduction of current peaks.
- Protection even for special motors.
- Detection of inversion of direction of rotation of phases.
- Contact for automatic emptying on stopping.

Conveyors

Standard*



- Gradual starting, reducing shocks and slipping of belts.
- Overload control to detect faults, hard spots or jamming, or underload control to detect breaks

* "Standard" or "severe" defines the type of application, so that the starter can be chosen from the selection guide.

Altistart 48 *selection guide*



* Starting time greater than 30 seconds (see previous page defining the types of application)

Starters 230 to 415 V - 50 / 60 Hz				Type of application	
Motor Power		Nominal current (IcL)	Standard class 10	Severes* class 20	
230 V Kw	400 V kW				
3	5,5	12			ATS 48D17Q
4	7,5	17	ATS 48D17Q		ATS 48D22Q
5,5	11	22	ATS 48D22Q		ATS 48D32Q
7,5	15	32	ATS 48D32Q		ATS 48D38Q
9	18,5	38	ATS 48D38Q		ATS 48D47Q
11	22	47	ATS 48D47Q		ATS 48D62Q
15	30	62	ATS 48D62Q		ATS 48D75Q
18,5	37	75	ATS 48D75Q		ATS 48D88Q
22	45	88	ATS 48D88Q		ATS 48C11Q
30	55	110	ATS 48C11Q		ATS 48C14Q
37	75	140	ATS 48C14Q		ATS 48C17Q
45	90	170	ATS 48C17Q		ATS 48C21Q
55	110	210	ATS 48C21Q		ATS 48C25Q
75	132	250	ATS 48C25Q		ATS 48C32Q
90	160	320	ATS 48C32Q		ATS 48C41Q
110	220	410	ATS 48C41Q		ATS 48C48Q
132	250	480	ATS 48C48Q		ATS 48C59Q
160	315	590	ATS 48C59Q		ATS 48C66Q
-	355	660	ATS 48C66Q		ATS 48C79Q
220	400	790	ATS 48C79Q		ATS 48M10Q
250	500	1000	ATS 48M10Q		ATS 48M12Q
355	630	1200	ATS 48M12Q		-

For the 230 to 415 V range, the starter can be connected in the delta connection of the motor to reduce the rating of the starter (please consult our catalog)

Starters 208 to 690 V - 50 / 60 Hz													Type of application	
Motor Power in HP				Motor Power in kW								Nominal current (IcL)	Standard class 10	Severes* class 20
208 V HP	230 V HP	460 V HP	575 V HP	230 V Kw	400 V kW	440 V kW	500 V kW	525 V kW	660 V kW	690 V kW	A			
2	3	7,5	10	3	5,5	5,5	7,5	7,5	9	11	12			ATS 48D17Y
3	5	10	15	4	7,5	7,5	9	9	11	15	17	ATS 48D17Y		ATS 48D22Y
5	7,5	15	20	5,5	11	11	11	11	15	18,5	22	ATS 48D22Y		ATS 48D32Y
7,5	10	20	25	7,5	15	15	18,5	18,5	22	22	32	ATS 48D32Y		ATS 48D38Y
10	-	25	30	9	18,5	18,5	22	22	30	30	38	ATS 48D38Y		ATS 48D47Y
-	15	30	40	11	22	22	30	30	37	37	47	ATS 48D47Y		ATS 48D62Y
15	20	40	50	15	30	30	37	37	45	45	62	ATS 48D62Y		ATS 48D75Y
20	25	50	60	18,5	37	37	45	45	55	55	75	ATS 48D75Y		ATS 48D88Y
25	30	60	75	22	45	45	65,5	55	75	75	88	ATS 48D88Y		ATS 48C11Y
30	40	75	100	30	55	55	75	75	90	90	110	ATS 48C11Y		ATS 48C14Y
40	50	100	125	37	75	75	90	90	110	110	140	ATS 48C14Y		ATS 48C17Y
50	60	125	150	45	90	90	110	110	132	160	170	ATS 48C17Y		ATS 48C21Y
60	75	150	200	55	110	110	132	132	160	200	210	ATS 48C21Y		ATS 48C25Y
75	100	200	250	75	132	132	160	160	220	250	250	ATS 48C25Y		ATS 48C32Y
100	125	250	300	90	160	160	220	220	250	315	320	ATS 48C32Y		ATS 48C41Y
125	150	300	350	110	220	220	250	250	355	400	410	ATS 48C41Y		ATS 48C48Y
150	-	350	400	132	250	250	315	315	400	500	480	ATS 48C48Y		ATS 48C59Y
-	200	400	500	160	315	355	400	400	560	560	590	ATS 48C59Y		ATS 48C66Y
200	250	500	600	-	355	400	-	-	630	630	660	ATS 48C66Y		ATS 48C79Y
250	300	600	800	220	400	500	500	500	710	710	790	ATS 48C79Y		ATS 48M10Y
350	350	800	1000	250	500	630	630	630	900	900	1000	ATS 48M10Y		ATS 48M12Y
400	455	1000	1200	355	630	710	800	800	-	-	1200	ATS 48M12Y		

A comprehensive range of *Motor Starters*

Increase your performance with the associated **TeSys** components*

■ Soft start - soft stop units



LH4
6 to 85 A



Altistart 48
17 to 1200 A

■ Variable speed drives



Altivar 11
0,18 to 2,2 kW



Altivar 38
0,75 to 315 kW



Altivar 28
0,37 to 15 kW



Altivar 58
0,37 to 75 kW



Altivar 68
75 to 630 kW



- Circuit-breakers,
- Contactors,
- Fuse
- ...
- up to the highest powers

**For further details on the combinations of products, please consult our catalog.*

A unique partner, a global presence

Constantly available, worldwide. With more than 5000 points of sale in 130 countries, you can be sure to find the range of products which is right for you and which complies totally with the standards in the country in which they are to be used.

Schneider Electric Services

Our services, near you, wherever you are. Our experts are at your disposal, working with you to design your customized solution. Our aim: to optimize your installations and improve your industrial performance.

Also available **in ready-assembled versions ready** for use in floor-mounted or wall-mounted enclosures.

Schneider Electric Industries S.A.

Head office

89 boulevard Franklin Roosevelt
92504 Rueil Malmaison Cedex
FRANCE
<http://www.schneider-electric.fr>

Owing to changes in standards and equipment, the characteristics given in the text and images in this document are not binding until they have been confirmed with us.

Production : 3000 NR

Photos : Schneider Electric - ImageBank

Soft starters

Altistart 48 soft start - soft stop units

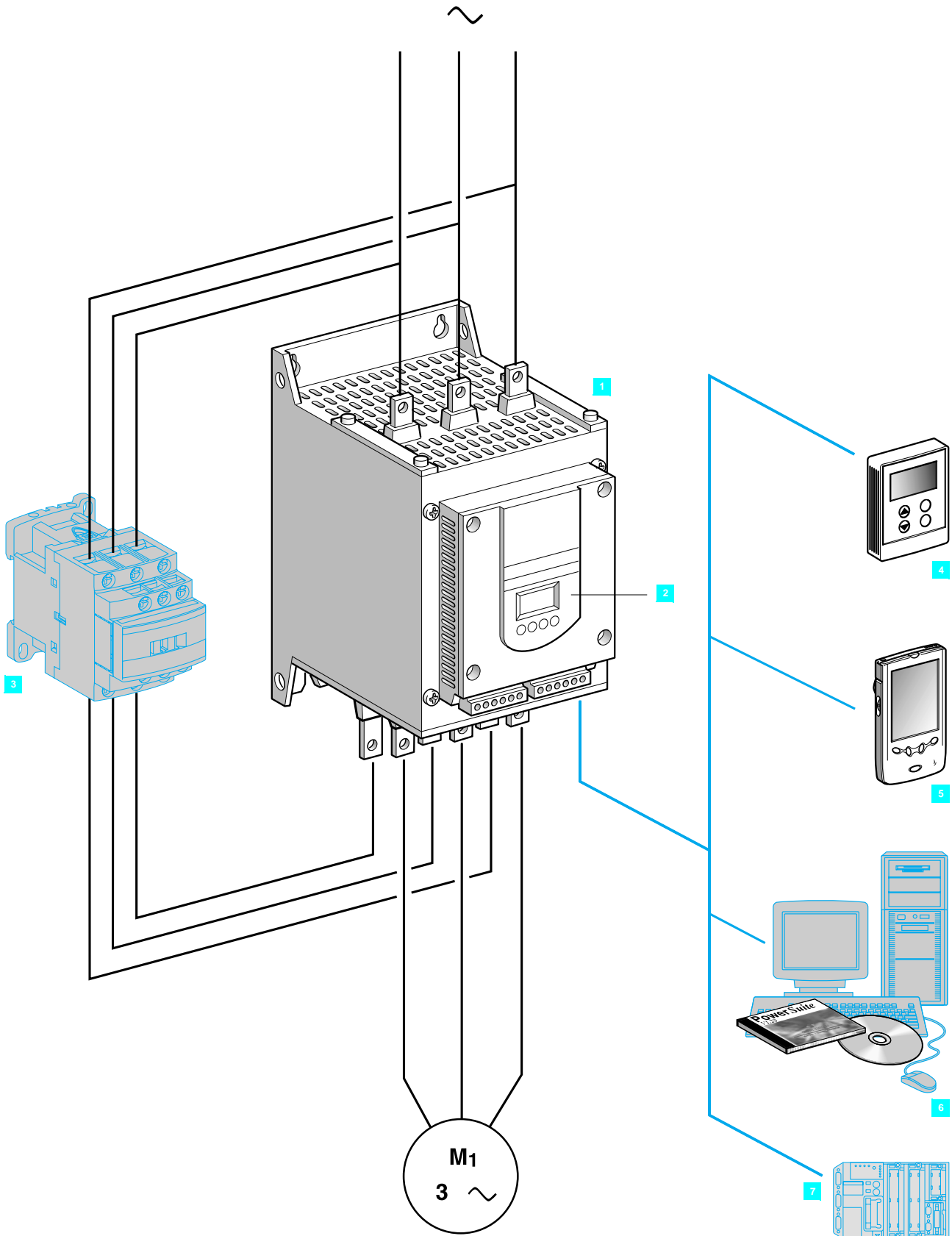

Applications

The Altistart 48 soft start - soft stop unit is a controller with 6 thyristors which is used for the torque-controlled soft starting and stopping of three-phase squirrel cage asynchronous motors in the power range between 4 and 1200 kW.

It offers soft starting and deceleration functions along with machine and motor protection functions as well as functions for communicating with control systems. These functions are designed for use in state-of-the-art applications in centrifugal machines, pumps, fans, compressors and conveyors, which are primarily to be found in the construction, food and beverages and chemical industries. The high-performance algorithms of the Altistart 48 contribute significantly to its robustness, safety and ease of setup.

The Altistart 48 soft start - soft stop unit is a cost-effective solution which can:

- Reduce machine operating costs by reducing mechanical stress and improving machine availability
- Reduce the stress placed on the electrical distribution system by reducing line current peaks and voltage drops during motor starts

The Altistart soft start - soft stop unit offer comprises 2 ranges:

- Three-phase voltages 230 to 415 V, 50/60 Hz
- Three-phase voltages 208 to 690 V, 50/60 Hz

In each voltage range, the Altistart soft start - soft stop units are dimensioned for standard and severe applications.

Functions

The Altistart 48 soft start - soft stop unit (1) is supplied ready for use in a standard application with motor protection class 10 (see page 60526/5).

It comprises a built-in terminal (2) which can be used to modify programming, adjustment or monitoring functions in order to adapt and customise the application to meet individual customer requirements.

■ Drive performance functions:

- Exclusive Altistart torque control (patented by Schneider Electric)
- Constant control of the torque supplied to the motor during acceleration and deceleration periods (significantly reducing pressure surges)
- Facility for adjusting the ramp and the starting torque
- The starter can be bypassed using a contactor (3) at the end of the starting period whilst maintaining electronic protection (bypass function)
- Wide frequency tolerance for generator set power supplies
- The starter can be connected to the motor delta terminals in series with each winding

■ Machine and motor protection functions:

- Built-in motor thermal protection
- Processing of information from PTC thermal probes
- Monitoring of the starting time
- Motor preheating function
- Protection against underloads and overcurrents during continuous operation

■ Functions facilitating the integration of the unit into control systems:

- 4 logic inputs, 2 logic outputs, 3 relay outputs and 1 analogue output
- Plug-in I/O connectors
- Function for configuring a second motor and easy-to-adapt settings
- Display of electrical values, the state of the load and the operating time
- RS 485 serial link for connection to Modbus

Options

A remote terminal (4) can be mounted on the door of a wall-fixing or floor-standing enclosure.

PowerSuite advanced dialogue solutions:

- PowerSuite Pocket PC with PPC type terminal (5),
- PowerSuite software workshop (6).

A range of wiring accessories for connecting the starter to PLCs via a Modbus connection (7).

Bus communication and Ethernet, Fipio, DeviceNet and Profibus DP network communication options

Soft starters

Altistart 48 soft start - soft stop units

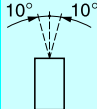
Environment				
Conformity to standards			The electronic starters have been developed and performance tested in accordance with international standards, in particular with the starter product standard EN/IEC 60947-4-2.	
CE marking			Products have CE marking in accordance with the harmonised standard EN/IEC 60947-4-2.	
Product approvals			UL, CSA Pending: DNV, C-Tick, Ghost, CCIB	
Degree of protection	Starters ATS 48D17● to 48C11● Starters ATS 48C14● to 48M12● (1)		IP 20 (IP 00 in the absence of connections) IP 00	
Vibration resistance	Conforming to IEC 60068-2-6		1.5 mm from 2 to 13 Hz 1gn from 13 to 200 Hz	
Shock resistance	Conforming to IEC 60068-2-27		15 g for 11 ms	
Starter noise level (2)	Starters ATS 48D32● to D47●	dBA	52	
	Starters ATS 48D62● to C11●	dBA	58	
	Starters ATS 48C14● to C17●	dBA	50	
	Starters ATS 48C21● to C32●	dBA	54	
	Starters ATS 48C41● to C66●	dBA	55	
	Starters ATS 48C79● to M12●	dBA	60	
Fans	Starters ATS 48D17● and D22● Starters ATS 48D32● to M12●		Natural convection Forced convection. The fans are activated automatically when a temperature threshold is reached. For flow rate see page 60523/5.	
	Ambient temperature around the unit	Operation	°C	- 10...+ 40 without derating (between + 40 and + 60, derate the nominal current of the Altistart by 2% for each °C).
	Storage, conforming to IEC 60947-4-2		°C	- 25...+ 70
Maximum relative humidity	Conforming to IEC 60068-2-3			95% without condensation or dripping water
Maximum ambient pollution	Conforming to IEC 60664-1			Level 3
Maximum operating altitude			m	1000 without derating (above this, derate the nominal current of the Altistart by 2.2% for each additional 100 m). Limit to 2000 m.
Operating position	Maximum permanent angle in relation to the normal vertical mounting position			

Electrical characteristics			
Operating category	Conforming to IEC 60947-4-2		AC-53a
Three-phase supply voltage	Starters ATS 48●●●Q	V	230 -15% to 415 + 10%
	Starters ATS 48●●●Y	V	208 - 15% to 690 + 10%
Frequency		Hz	50/60 ± 5% (automatic) 50 or 60 ± 20% (must be set)
Nominal starter current	Starters ATS 48●●●Q	A	17...1200
	Starters ATS 48●●●Y	A	17 to 1200
Motor power	Starters ATS 48●●●Q	kW	4 to 630
	Starters ATS 48●●●Y	kW/HP	5.5 to 900/5 to 1200
Voltage indicated on the motor rating plate	Starters ATS 48●●●Q	V	230 to 415
	Starters ATS 48●●●Y	V	208 to 690
Starter control circuit supply voltage	Starters ATS 48●●●Q	V	220 - 15% to 415 + 10%, 50/60 Hz
	Starters ATS 48●●●Y	V	110 - 15% to 230 + 10%, 50/60 Hz
Maximum control circuit consumption (with fans operating)	Starters ATS 48D17● to C17●	W	30
	Starters ATS 48C21● to C32●	W	50
	Starters ATS 48C41● to M12●	W	80
Relay output (2 configurable outputs)	3 relay outputs (R1, R2, R3), normally open contacts 1"N/O" Minimum switching capacity: 10 mA for ~ 6 V. Maximum switching capacity on inductive load: 1.8 A for ~ 230 V and ~ 30 V (cos φ= 0.5 and L/R=20ms). Maximum nominal operating voltage ~ 400 V. Factory setting: R1 assigned as the "fault relay" (configurable) R2 assigned as the "end of starting relay" to control the starter bypass relay R3 assigned as "motor powered" (configurable)		

(1) Protective covers can be fitted to the power terminals of ATS 48C14● to C32● starters. ATS 48C41● to 48M12● starters have protection on the front panel and on the sides.

(2) Starters located 1 m away. The noise levels may change depending on the characteristics of the fans.

Electrical characteristics (continued)

Logic inputs LI (2 configurable inputs)		4 logic inputs, impedance 4.3 kΩ, isolated: Stop, Run, LI3, LI4. + 24 V power supply (maximum 30 V) I max. 8 mA State 0 if U < 5 V and I < 2 mA State 1 if U > 11 V and I > 5 mA
Internal source available		1 x + 24 V output, isolated and protected against short-circuits and overloads. Accuracy ± 25%. Max. current 200 mA.
Logic outputs LO (configurable)		2 logic outputs LO1 and LO2 with 0 V common, compatible with level 1 PLC, according to standard IEC 65A-68. + 24 V power supply (minimum: +12 V, maximum: +30 V). Maximum output current: 200 mA if supplied externally
Analogue output AO (configurable)		Current output 0-20 mA or 4-20 mA Maximum load impedance: 500 Ω Accuracy ± 5% of the maximum value
Input for PTC probe		Total resistance of probe circuit 750 Ω at 25°C, according to IEC 60 738-A
Maximum I/O connection capacity		2.5 mm ² (AWG 12)
Communication		RS 485 multidrop serial link integrated in the starter, for Modbus, with RJ45 type connector Transmission speed 4800, 9600 or 19200 bps Maximum number of Altistart 48 connected: 18 Other uses: - connection to a remote terminal or - connection to a PC or - connection to other buses and networks via communication options.
Protection	Thermal	Built-in, starter and motor (calculated and/or thermal protection with PTC probes)
	Line protection	Phase failure, indicated by output relay
Current settings		The nominal motor current I _n can be adjusted from 0.4 to 1.3 times the starter nominal current. Adjustment of the maximum starting current from 1.5 to 7 times the motor I _n , limited to 5 times the starter nominal current.
Starting mode		By torque control with starter current limited to 5 I _n maximum. Factory setting: 4 I _n for standard operation on 15 s torque ramp
Stopping mode	Freewheel stop	"Freewheel" stop (factory setting)
	Controlled stop on torque ramp	Programmed between 0.5 and 60 s (for pump applications)
	Braked stop	Controlled dynamically by the flux

Electromagnetic compatibility EMC (1)

	Standards	Test levels	Examples (sources of interference)
Summary of immunity tests carried out with the Altistart 48	IEC 61000-4-2 level 3 Electrostatic discharge: - by contact - in the air	6 kV 8 kV	Contact off an electrically charged individual
	IEC 61000-4-3 level 3 Radiated electromagnetic fields	10 V/m	Equipment transmitting radio frequencies
	IEC 61000-4-4 level 4 Rapid electrical transients: - power supply cables - control cables	4 kV 2 kV	Opening/closing of a contactor
	IEC 61000-4-5 level 3 Shock wave: - phase/phase - phase/earth	1 kV 2 kV	-
	IEC 61000-4-12 level 3 Damped oscillating waves	1 kV - 1 MHz	Oscillating circuit on the line supply
Radiated and conducted emissions	According to IEC 60947-4-2, class A, on all starters According to IEC 60947-4-2, class B, on starters up to 170 A: ATS 48D17● to 48C17●. Must be bypassed at the end of starting		

(1) The starters conform to product standard IEC 60947-4-2, in particular with regard to EMC. This standard ensures a level of immunity for products and a level of emitted interference. In steady state, the interference emitted is below that required by the standard. During acceleration and deceleration phases, low level loads may be affected by low frequency interference (harmonics). To reduce this interference, connect chokes between the line supply and the Altistart 48 (see page 60528/3).

Note:

- Power factor correction capacitors can only be used upstream of the Altistart and only powered up at the end of starting.
- The starter must be earthed to conform to the regulations concerning leakage currents (≤ 30 mA). When the use of an upstream "residual current device" for protection is required by the installation standards, an A-Si type device must be used. Check its compatibility with the other protective devices. If the installation involves several starters on the same line supply, each starter must be earthed separately.

Torque characteristics

Curves indicating changes in the torque depending on the starting current of a three-phase asynchronous motor.

Curves 1: direct line starting

Curves 2: starting in current limiting mode

Torque curve T_{s1} indicates the total torque range available depending on the limiting current I_{s1} .

Limiting the starting current I_s to a preset value I_{s1} will reduce the starting torque T_{s1} to a value which is almost equal to the square of currents I_{s1}/I_s .

Example:

For motor characteristics: $T_s = 3 T_n$ for $I_s = 6 I_n$,

limit the current to $I_{s1} = 3 I_n$ (0.5 I_s)

resulting in a starting torque $T_{s1} = T_s \times (0.5)^2 = 3 T_n \times 0.25 = 0.75 T_n$

Starting current

- 1 Direct line starting current
- 2 Starting current limited to I_{s1}

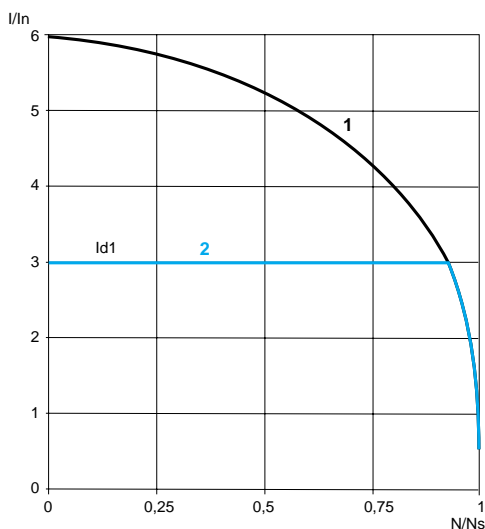

Starting torque

- 1 Direct line starting torque
- 2 Starting torque with current limited to I_{s1}

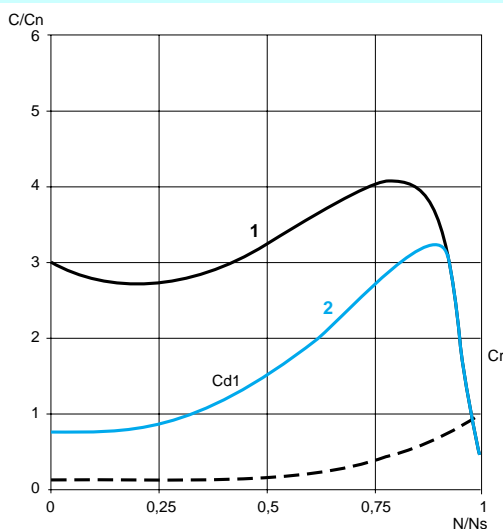

Conventional starting using current limitation or voltage ramp

With current limitation I_{s1} , the accelerating torque applied to the motor is equal to the motor torque T_{s1} minus the resistive torque T_r . The accelerating torque increases in the starting range as the speed changes and is at its highest at the end of acceleration (curve 2). This characteristic means that the load is taken up very abruptly, which is not recommended for pump type applications.

Example of speed curve for starting with current limitation

- 1 Current applied to the motor (I/I_n)
- 2 Motor speed N/N_s

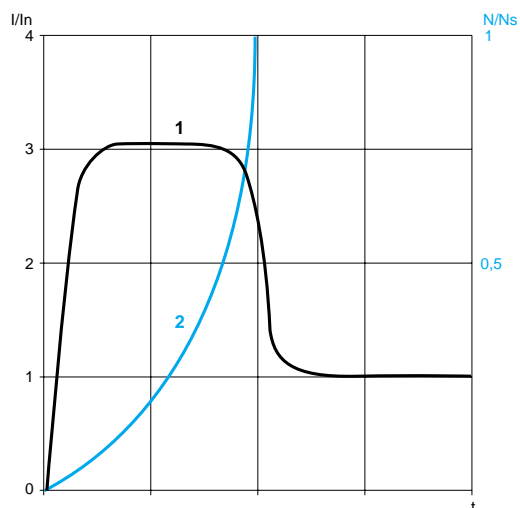

Starting with the Altistart 48

Torque control on the Altistart 48 applies the torque to the motor during the entire starting phase if the current required (curve 1) does not exceed the limiting current. The accelerating torque can be virtually constant over the entire speed range (curve 2). It is possible to set the Altistart in order to obtain a high torque on starting for a rapid motor speed rise whilst limiting its temperature rise, and a lower accelerating torque at the end of starting for gradual loading. This control function is ideal for centrifugal pumps or for machines with high resistive torque on starting.

Example of speed curve for starting with torque control

- 1 Current applied to the motor (I/I_n)
- 2 Motor speed N/N_s

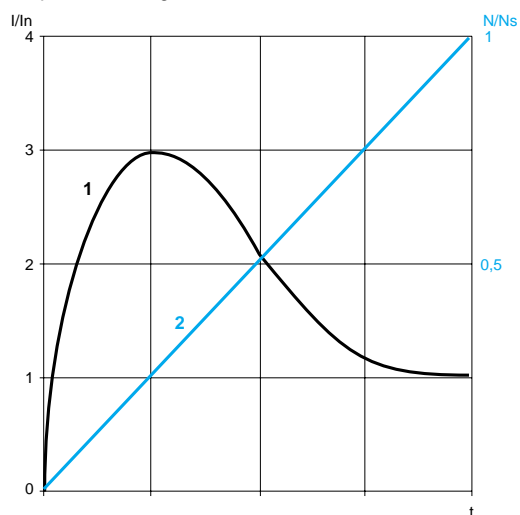

Stopping with the Altistart 48

- Freewheel stop: the motor comes to a freewheel stop.
- Decelerated stop: this type of stop is ideal for pumps and can be used to effectively reduce pressure surges. Torque control on the Altistart 48 reduces the effect of hydraulic transients even if the load increases. This type of control makes adjustment easy.
- Braked stop: this type of stop is suitable for high inertia applications as it reduces the stopping time of the machine.

Soft starters

Altistart 48 soft start - soft stop units

Line voltage 230/415 V

Connection in the motor supply line



ATS 48D17Q



ATS 48C14Q



ATS 48M12Q

For standard applications

Motor		Starter 230/415 V - 50/60 Hz				
Motor power (1)		Nominal current (lCL) (2)	Factory setting current (4)	Power dissipated at nominal load	Reference	Weight
230 V	400 V	A	A	W		kg
kW	kW					
4	7.5	17	14.8	59	ATS 48D17Q	4.900
5.5	11	22	21	74	ATS 48D22Q	4.900
7.5	15	32	28.5	104	ATS 48D32Q	4.900
9	18.5	38	35	116	ATS 48D38Q	4.900
11	22	47	42	142	ATS 48D47Q	4.900
15	30	62	57	201	ATS 48D62Q	8.300
18.5	37	75	69	245	ATS 48D75Q	8.300
22	45	88	81	290	ATS 48D88Q	8.300
30	55	110	100	322	ATS 48C11Q	8.300
37	75	140	131	391	ATS 48C14Q	12.400
45	90	170	162	479	ATS 48C17Q	12.400
55	110	210	195	580	ATS 48C21Q	18.200
75	132	250	233	695	ATS 48C25Q	18.200
90	160	320	285	902	ATS 48C32Q	18.200
110	220	410	388	1339	ATS 48C41Q	51.400
132	250	480	437	1386	ATS 48C48Q	51.400
160	315	590	560	1731	ATS 48C59Q	51.400
–	355	660	605	1958	ATS 48C66Q	51.400
220	400	790	675	2537	ATS 48C79Q	115.000
250	500	1000	855	2865	ATS 48M10Q	115.000
355	630	1200	1045	3497	ATS 48M12Q	115.000

For severe applications

Motor		Starter 230/415 V - 50/60 Hz				
Motor power (1)		Nominal current (3)	Factory setting current (4)	Power dissipated at nominal load	Reference	Weight
230 V	400 V	A	A	W		kg
kW	kW					
3	5.5	12	14.8	46	ATS 48D17Q	4.900
4	7.5	17	21	59	ATS 48D22Q	4.900
5.5	11	22	28.5	74	ATS 48D32Q	4.900
7.5	15	32	35	99	ATS 48D38Q	4.900
9	18.5	38	42	116	ATS 48D47Q	4.900
11	22	47	57	153	ATS 48D62Q	8.300
15	30	62	69	201	ATS 48D75Q	8.300
18.5	37	75	81	245	ATS 48D88Q	8.300
22	45	88	100	252	ATS 48C11Q	8.300
30	55	110	131	306	ATS 48C14Q	12.400
37	75	140	162	391	ATS 48C17Q	12.400
45	90	170	195	468	ATS 48C21Q	18.200
55	110	210	233	580	ATS 48C25Q	18.200
75	132	250	285	695	ATS 48C32Q	18.200
90	160	320	388	1017	ATS 48C41Q	51.400
110	220	410	437	1172	ATS 48C48Q	51.400
132	250	480	560	1386	ATS 48C59Q	51.400
160	315	590	605	1731	ATS 48C66Q	51.400
–	355	660	675	2073	ATS 48C79Q	115.000
220	400	790	855	2225	ATS 48M10Q	115.000
250	500	1000	1045	2865	ATS 48M12Q	115.000

(1) Value indicated on the motor rating plate

(2) Corresponds to the maximum permanent current in class 10. lCL corresponds to the starter rating.

(3) Corresponds to the maximum permanent current in class 20.

(4) The factory setting current corresponds to the value of the nominal current of a standard 4-pole, 400 V, class 10 motor (standard application). Adjust the settings in accordance with the motor nominal current.

Soft starters

Altistart 48 soft start - soft stop units

Line voltage 230/415 V

Connection to the motor delta terminals

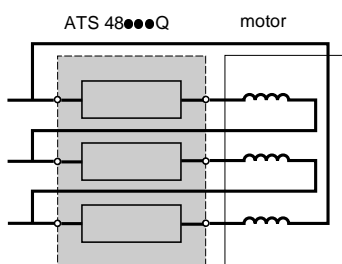

Figure 1

Special use:

Starter connected to the motor delta terminal in series with each winding

For standard applications according to Figure 1

Motor		Starter 230/415 V - 50/60 Hz					
Motor power (1)			Nominal current (2)	Factory setting current (4)	Power dissipated at nominal load	Reference	Weight
	230 V	400 V					
7.5	15	29	14.8	59	ATS 48D17Q	4.900	
9	18.5	38	21	74	ATS 48D22Q	4.900	
15	22	55	28.5	104	ATS 48D32Q	4.900	
18.5	30	66	35	116	ATS 48D38Q	4.900	
22	45	81	42	142	ATS 48D47Q	4.900	
30	55	107	57	201	ATS 48D62Q	8.300	
37	55	130	69	245	ATS 48D75Q	8.300	
45	75	152	81	290	ATS 48D88Q	8.300	
55	90	191	100	322	ATS 48C11Q	8.300	
75	110	242	131	391	ATS 48C14Q	12.400	
90	132	294	162	479	ATS 48C17Q	12.400	
110	160	364	195	580	ATS 48C21Q	18.200	
132	220	433	233	695	ATS 48C25Q	18.200	
160	250	554	285	902	ATS 48C32Q	18.200	
220	315	710	388	1339	ATS 48C41Q	51.400	
250	355	831	437	1386	ATS 48C48Q	51.400	
-	400	1022	560	1731	ATS 48C59Q	51.400	
315	500	1143	605	1958	ATS 48C66Q	51.400	
355	630	1368	675	2537	ATS 48C79Q	115.000	
-	710	1732	855	2865	ATS 48M10Q	115.000	
500	-	2078	1045	3497	ATS 48M12Q	115.000	

For severe applications according to Figure 1

Motor		Starter 230/415 V - 50/60 Hz					
Motor power (1)			Nominal current (3)	Factory setting current (4)	Power dissipated at nominal load	Reference	Weight
	230 V	400 V					
5.5	11	22	14.8	46	ATS 48D17Q	4.900	
7.5	15	29	21	59	ATS 48D22Q	4.900	
9	18.5	38	28.5	74	ATS 48D32Q	4.900	
15	22	55	35	99	ATS 48D38Q	4.900	
18.5	30	66	42	116	ATS 48D47Q	4.900	
22	45	81	57	153	ATS 48D62Q	8.300	
30	55	107	69	201	ATS 48D75Q	8.300	
37	55	130	81	245	ATS 48D88Q	8.300	
45	75	152	100	252	ATS 48C11Q	8.300	
55	90	191	131	306	ATS 48C14Q	12.400	
75	110	242	162	391	ATS 48C17Q	12.400	
90	132	294	195	468	ATS 48C21Q	18.200	
110	160	364	233	580	ATS 48C25Q	18.200	
132	220	433	285	695	ATS 48C32Q	18.200	
160	250	554	388	1017	ATS 48C41Q	51.400	
220	315	710	437	1172	ATS 48C48Q	51.400	
250	355	831	560	1386	ATS 48C59Q	51.400	
-	400	1022	605	1731	ATS 48C66Q	51.400	
315	500	1143	675	2073	ATS 48C79Q	115.000	
355	630	1368	855	2225	ATS 48M10Q	115.000	
-	710	1732	1045	2865	ATS 48M12Q	115.000	

(1) Value indicated on the motor rating plate

(2) Corresponds to the maximum permanent current in class 10.

(3) Corresponds to the maximum permanent current in class 20.

(4) For this type of connection, the factory setting current must be adjusted in accordance with the nominal motor current.

Soft starters

Altistart 48 soft start - soft stop units

Line voltage 208/690 V

Motor power in HP



ATS 48D17Y



ATS 48C14Y



ATS 48M12Y

For standard applications

Motor					Starter 208/690 V - 50/60 Hz				
Motor power (1)					Nominal current (IcL) (2)	Factory setting current (4)	Power dissipated at nominal load	Reference	Weight
208 V	230 V	460 V	575 V	A					
HP	HP	HP	HP	A	A	W		kg	
3	5	10	15	17	14	59	ATS 48D17Y	4.900	
5	7.5	15	20	22	21	74	ATS 48D22Y	4.900	
7.5	10	20	25	32	27	104	ATS 48D32Y	4.900	
10	–	25	30	38	34	116	ATS 48D38Y	4.900	
–	15	30	40	47	40	142	ATS 48D47Y	4.900	
15	20	40	50	62	52	201	ATS 48D62Y	8.300	
20	25	50	60	75	65	245	ATS 48D75Y	8.300	
25	30	60	75	88	77	290	ATS 48D88Y	8.300	
30	40	75	100	110	96	322	ATS 48C11Y	8.300	
40	50	100	125	140	124	391	ATS 48C14Y	12.400	
50	60	125	150	170	156	479	ATS 48C17Y	12.400	
60	75	150	200	210	180	580	ATS 48C21Y	18.200	
75	100	200	250	250	240	695	ATS 48C25Y	18.200	
100	125	250	300	320	302	902	ATS 48C32Y	18.200	
125	150	300	350	410	361	1339	ATS 48C41Y	51.400	
150	–	350	400	480	414	1386	ATS 48C48Y	51.400	
–	200	400	500	590	477	1731	ATS 48C59Y	51.400	
200	250	500	600	660	590	1958	ATS 48C66Y	51.400	
250	300	600	800	790	720	2537	ATS 48C79Y	115.000	
350	350	800	1000	1000	954	2865	ATS 48M10Y	115.000	
400	450	1000	1200	1200	1170	3497	ATS 48M12Y	115.000	

For severe applications

Motor					Starter 208/690 V - 50/60 Hz				
Motor power (1)					Nominal current (3)	Factory setting current (4)	Power dissipated at nominal load	Reference	Weight
208 V	230 V	460 V	575 V	A					
HP	HP	HP	HP	A	A	W		kg	
2	3	7.5	10	12	14	46	ATS 48D17Y	4.900	
3	5	10	15	17	21	59	ATS 48D22Y	4.900	
5	7.5	15	20	22	27	74	ATS 48D32Y	4.900	
7.5	10	20	25	32	34	99	ATS 48D38Y	4.900	
10	–	25	30	38	40	116	ATS 48D47Y	4.900	
–	15	30	40	47	52	153	ATS 48D62Y	8.300	
15	20	40	50	62	65	201	ATS 48D75Y	8.300	
20	25	50	60	75	77	245	ATS 48D88Y	8.300	
25	30	60	75	88	96	252	ATS 48C11Y	8.300	
30	40	75	100	110	124	306	ATS 48C14Y	12.400	
40	50	100	125	140	156	391	ATS 48C17Y	12.400	
50	60	125	150	170	180	468	ATS 48C21Y	18.200	
60	75	150	200	210	240	580	ATS 48C25Y	18.200	
75	100	200	250	250	302	695	ATS 48C32Y	18.200	
100	125	250	300	320	361	1017	ATS 48C41Y	51.400	
125	150	300	350	410	414	1172	ATS 48C48Y	51.400	
150	–	350	400	480	477	1386	ATS 48C59Y	51.400	
–	200	400	500	590	590	1731	ATS 48C66Y	51.400	
200	250	500	600	660	720	2073	ATS 48C79Y	115.000	
250	300	600	800	790	954	2225	ATS 48M10Y	115.000	
350	350	800	1000	1000	1170	2865	ATS 48M12Y	115.000	

(1) Value indicated on the motor rating plate

(2) Corresponds to the maximum permanent current in class 10. I_{cL} corresponds to the starter rating.

(3) Corresponds to the maximum permanent current in class 20.

(4) The factory setting current corresponds to the value of the nominal current of a standard motor according to NEC, 460 V, class 10 (standard application). Adjust the settings in accordance with the motor nominal current.

Soft starters

Altistart 48 soft start - soft stop units

Line voltage 208/690 V

Motor power in kW

For standard applications

Motor							Starter 208/690 V - 50/60 Hz				
Motor power (1)							Nominal current (IcL) (2)	Factory setting current (4)	Power dissipated at nominal load	Reference	Weight
230 V	400 V	440 V	500 V	525 V	660 V	690 V					
kW	kW	kW	kW	kW	kW	kW					
4	7.5	7.5	9	9	11	15	17	14	59	ATS 48D17Y	4.900
5.5	11	11	11	11	15	18.5	22	21	74	ATS 48D22Y	4.900
7.5	15	15	18.5	18.5	22	22	32	27	104	ATS 48D32Y	4.900
9	18.5	18.5	22	22	30	30	38	34	116	ATS 48D38Y	4.900
11	22	22	30	30	37	37	47	40	142	ATS 48D47Y	4.900
15	30	30	37	37	45	45	62	52	201	ATS 48D62Y	8.300
18.5	37	37	45	45	55	55	75	65	245	ATS 48D75Y	8.300
22	45	45	55	55	75	75	88	77	290	ATS 48D88Y	8.300
30	55	55	75	75	90	90	110	96	322	ATS 48C11Y	8.300
37	75	75	90	90	110	110	140	124	391	ATS 48C14Y	12.400
45	90	90	110	110	132	160	170	156	479	ATS 48C17Y	12.400
55	110	110	132	132	160	200	210	180	580	ATS 48C21Y	18.200
75	132	132	160	160	220	250	250	240	695	ATS 48C25Y	18.200
90	160	160	220	220	250	315	320	302	902	ATS 48C32Y	18.200
110	220	220	250	250	355	400	410	361	1339	ATS 48C41Y	51.400
132	250	250	315	315	400	500	480	414	1386	ATS 48C48Y	51.400
160	315	355	400	400	560	560	590	477	1731	ATS 48C59Y	51.400
–	355	400	–	–	630	630	660	590	1958	ATS 48C66Y	51.400
220	400	500	500	500	710	710	790	720	2537	ATS 48C79Y	115.000
250	500	630	630	630	900	900	1000	954	2865	ATS 48M10Y	115.000
355	630	710	800	800	–	–	1200	1170	3497	ATS 48M12Y	115.000

For severe applications

Motor							Starter 208/690 V - 50/60 Hz				
Motor power (1)							Nominal current (3)	Factory setting current (4)	Power dissipated at nominal load	Reference	Weight
230 V	400 V	440 V	500 V	525 V	660 V	690 V					
kW	kW	kW	kW	kW	kW	kW					
3	5.5	5.5	7.5	7.5	9	11	12	14	46	ATS 48D17Y	4.900
4	7.5	7.5	9	9	11	15	17	21	59	ATS 48D22Y	4.900
5.5	11	11	11	11	15	18.5	22	27	74	ATS 48D32Y	4.900
7.5	15	15	18.5	18.5	22	22	32	34	99	ATS 48D38Y	4.900
9	18.5	18.5	22	22	30	30	38	40	116	ATS 48D47Y	4.900
11	22	22	30	30	37	37	47	52	153	ATS 48D62Y	8.300
15	30	30	37	37	45	45	62	65	201	ATS 48D75Y	8.300
18.5	37	37	45	45	55	55	75	77	245	ATS 48D88Y	8.300
22	45	45	55	55	75	75	88	96	252	ATS 48C11Y	8.300
30	55	55	75	75	90	90	110	124	306	ATS 48C14Y	12.400
37	75	75	90	90	110	110	140	156	391	ATS 48C17Y	12.400
45	90	90	110	110	132	160	170	180	468	ATS 48C21Y	18.200
55	110	110	132	132	160	200	210	240	580	ATS 48C25Y	18.200
75	132	132	160	160	220	250	250	302	695	ATS 48C32Y	18.200
90	160	160	220	220	250	315	320	361	1017	ATS 48C41Y	51.400
110	220	220	250	250	355	400	410	414	1172	ATS 48C48Y	51.400
132	250	250	315	315	400	500	480	477	1386	ATS 48C59Y	51.400
160	315	355	400	400	560	560	590	590	1731	ATS 48C66Y	51.400
–	355	400	–	–	630	630	660	720	2073	ATS 48C79Y	115.000
220	400	500	500	500	710	710	790	954	2225	ATS 48M10Y	115.000
250	500	630	630	630	900	900	1000	1170	2865	ATS 48M12Y	115.000

(1) Value indicated on the motor rating plate

(2) Corresponds to the maximum permanent current in class 10. I_{cL} corresponds to the starter rating.

(3) Corresponds to the maximum permanent current in class 20.

(4) The factory setting current corresponds to the value of the nominal current of a standard motor according to NEC, 460 V, class 10 (standard application). Adjust the settings in accordance with the motor nominal current.

Soft starters

Altistart 48 soft start - soft stop units

ATS 48D17● to ATS 48D47●

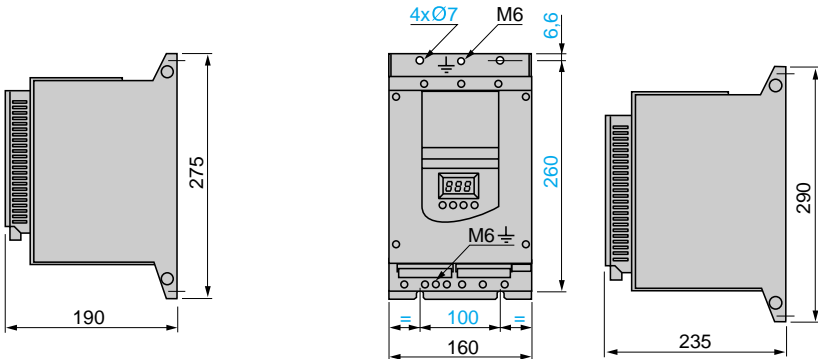

Maximum connection capacity:
 Earth connections: 10 mm² (AWG 8)
 Power terminals: 16 mm² (AWG 8)

ATS 48D62● to ATS 48C11●

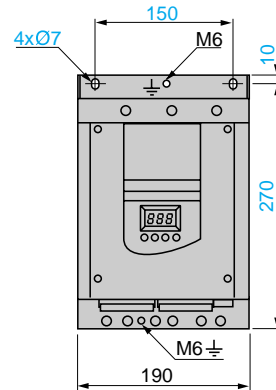

Maximum connection capacity:
 Earth connections: 16 mm² (AWG 4)
 Power terminals: 50 mm² (AWG 2/0)

ATS 48C14● to ATS 48C17●

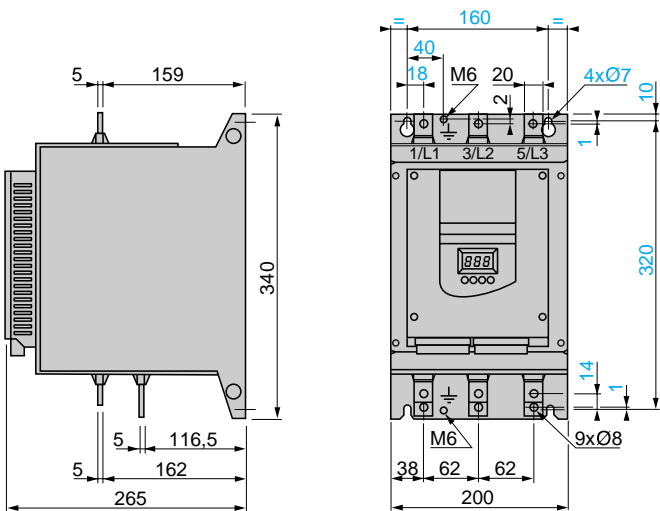

Maximum connection capacity:
 Earth connections: 120 mm² (busbar)
 Power terminals: 95 mm² (AWG 2/0)

ATS 48C21● to ATS 48C32●

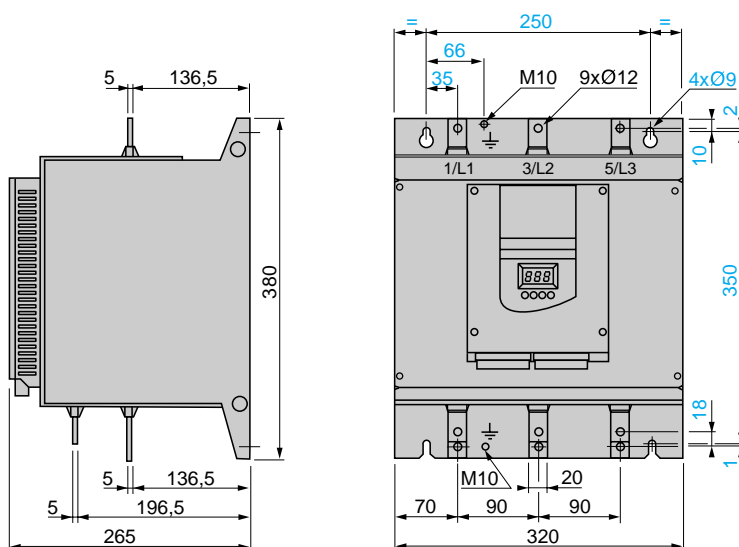

Maximum connection capacity:
 Earth connections: 120 mm² (busbar)
 Power terminals: 240 mm² (busbar)

ATS 48C41 to C66

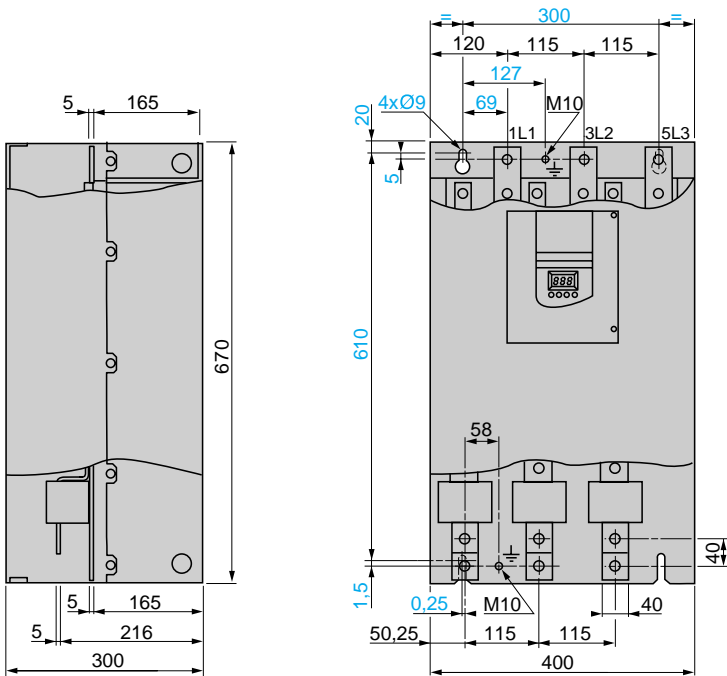

Maximum connection capacity:

Earth connections:

240 mm² (busbar)

Power terminals:

2 x 240 mm² (busbar)

ATS 48C79 to M12

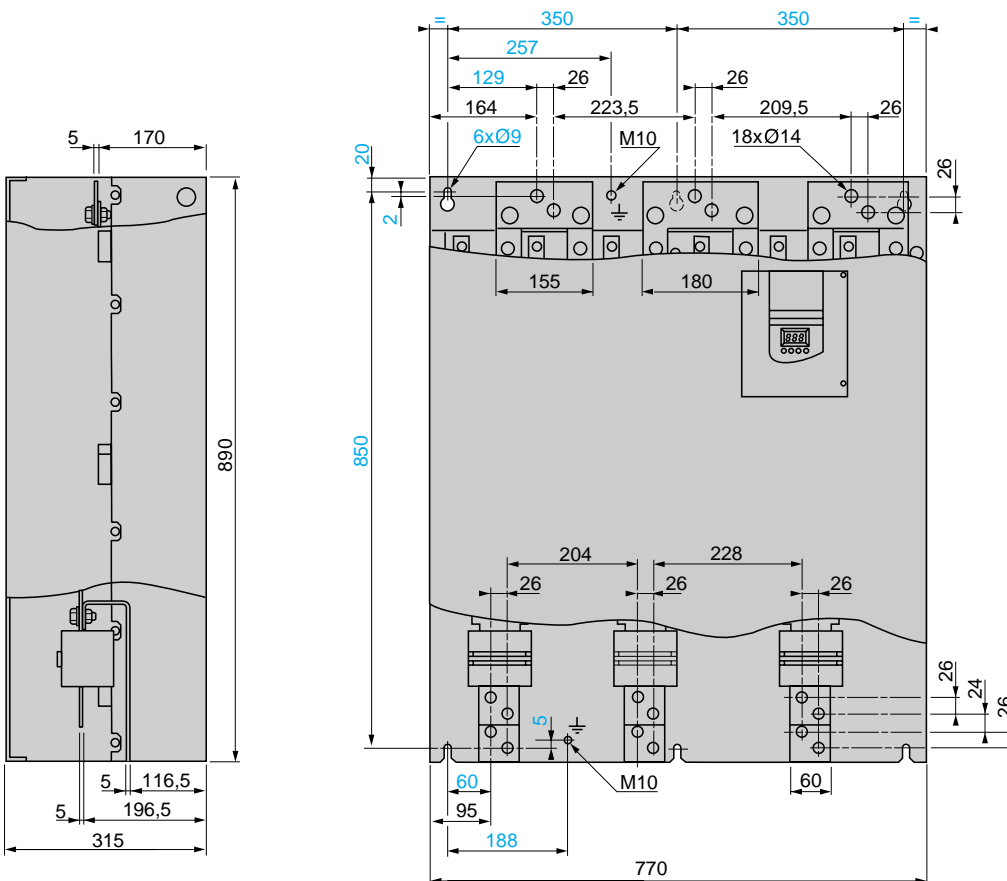

Maximum connection capacity:

Earth connections:

2 x 240 mm² (busbar)

Power terminals:

4 x 240 mm² (busbar)

Chokes

VZ1-L015UM17T to L070U350T

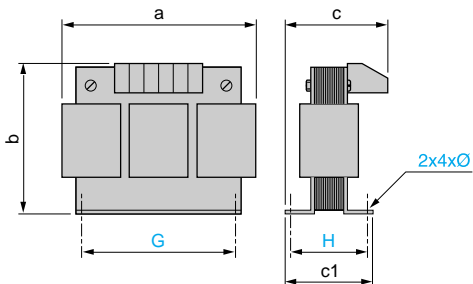

VZ1-L150U170T to LM14U016T

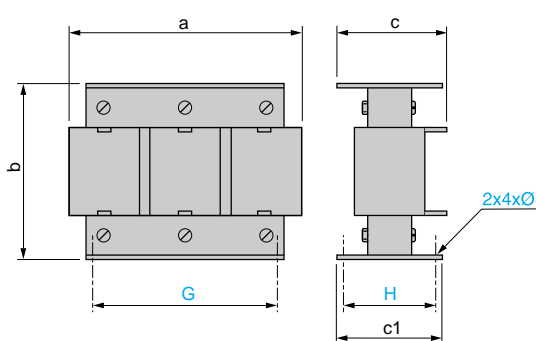

VZ1-	a	b	c	c1	G	H	Ø
L015UM17T	120	150	80	75	60/80.5	52	6
L030U800T	150	180	120	100	75/106.5	76	7
L040U600T	180	215	130	100	85/122	76	7
L070U350T	180	215	150	130	85/122	97	7

VZ1-	a	b	c	c1	G	H	Ø
L150U170T	270	240	170	140	105/181	96	11.5
L250U100T	270	240	220	160	105/181	125	11.5
L325U075T	270	240	240	175	105/181	138	11.5
L530U045T	380	410	225	140	310	95	9
LM10U024T	400	410	310	170	310	125	9
LM14U016T	420	490	340	170	310	125	9

Mounting the remote terminal

VW3 G48101

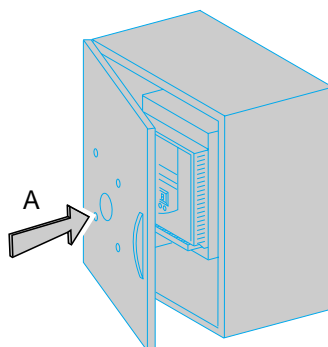
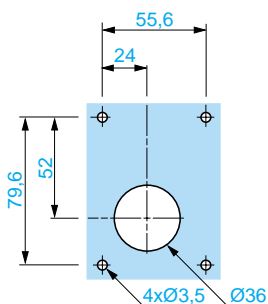

Mounting recommendations

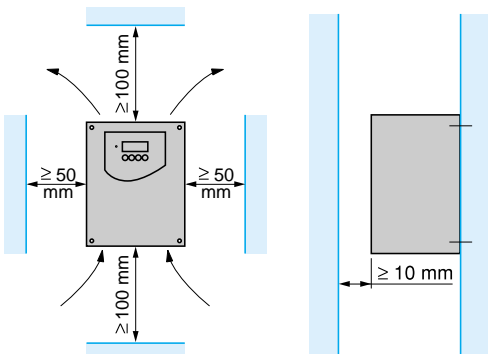

- Install the Altistart vertically, at $\pm 10^\circ$.
- Do not place the Altistart close to or above heating elements.
- Leave sufficient free space to ensure that the air required for cooling purposes can circulate from the bottom to the top of the unit.

Caution: The IP 00 version of the Altistart 48 must be fitted with a protective bar to protect personnel against electrical contact. Protective covers are available for the ATS 48C14● to ATS 48C32●. They should be ordered separately.

Mounting in a metal wall-fixing or floor-standing enclosure with degree of protection IP 23 or IP 54

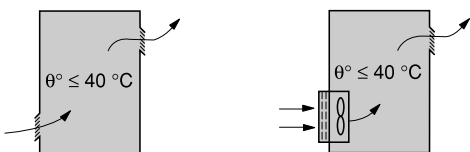

- Observe the mounting recommendations above.
- To ensure proper air circulation in the starter:
 - Fit ventilation grilles
 - Ensure that there is sufficient ventilation. If there is not, install forced ventilation with a filter. The openings and/or fans must provide a flow rate at least equal to that of the starter fans (see the table below)
 - Use special filters with IP 54 protection.

Fan flow rate depending on the starter rating

ATS 48 starter	Flow rate m ³ /hour
ATS48 D32● and D38●	14
ATS48 D47●	28
ATS48 D62● to C11●	86
ATS48 C14● and C17●	138
ATS48 C21● to C32●	280
ATS48 C41● to C66●	600
ATS48 C29● to M12●	1200

Metal wall-fixing or floor-standing enclosure with IP 54 degree of protection
 For non-ventilated Altistart units (ATS 48D17● and 48D22●), install a fan ≤ 50 mm below the starter to circulate the air inside the enclosure in order to avoid hot spots.

Calculating the size of the enclosure

Maximum thermal resistance R_{th} (°C/W)

$$R_{th} = \frac{\theta - \theta_e}{P}$$

θ = maximum temperature inside enclosure in °C
 θ_e = maximum external temperature in °C
 P = total power dissipated in the enclosure in W

The starter/motor combinations on pages 60522/2 and 60522/3 can only be used in ambient temperatures $\leq 40^\circ\text{C}$.
 For temperatures between 40°C and 60°C , derate the maximum permanent current of the starter by 2% for every degree above 40°C .
 Power dissipated by the starter: see pages 60522/2 and 60522/3.
 If the starts are infrequent, it is advisable to bypass the Altistart at the end of starting in order to reduce heat dissipation.
 The power dissipated will then be between 15 and 30 W.
 Add the power dissipated by the other equipment components.

Effective exchange surface area of enclosure S (m²)

(sides + top + front panel if wall-mounted)

$$S = \frac{K}{R_{th}}$$

K is the thermal resistance per m² of casing

For ACM type metal enclosures: K = 0.12 with internal fan, K = 0.15 without fan
Caution: Do not use insulated enclosures as they have a poor level of conductivity.

Recommended application diagram for non-reversing unit with line contactor, type 1 and type 2 coordination

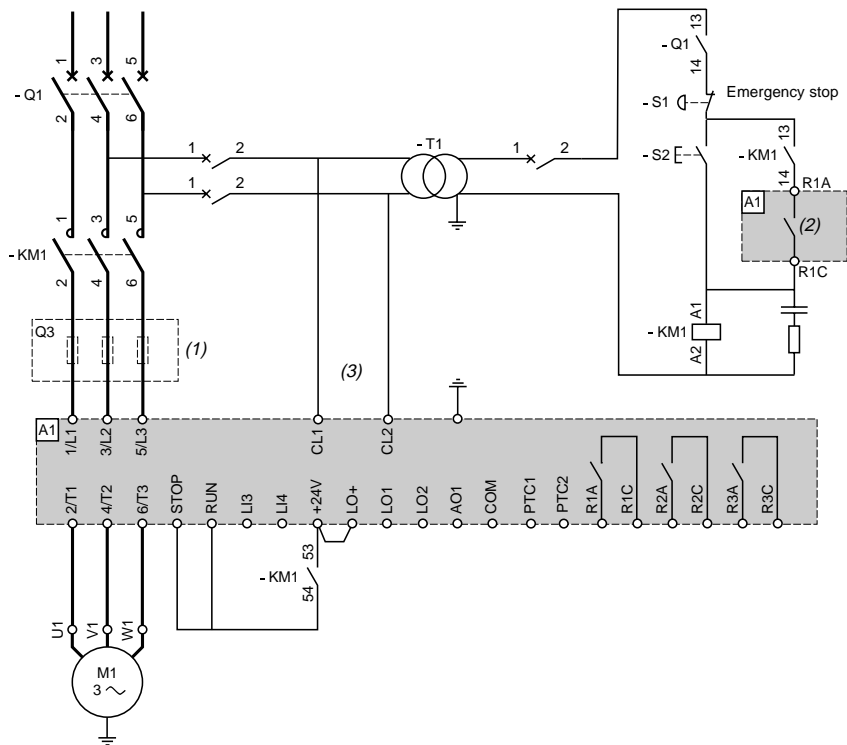

Select the components to connect, according to the descriptions on page 60524/3, from the association tables on pages 60525/2 to 60525/11.

- (1) For type 2 coordination (according to IEC 60947-4-2), install fast-acting fuses to ensure that the starter will be protected in the event of a short-circuit.
- (2) Assign relay R1 as the "isolating relay". Beware of the operating limits of the contacts (see Characteristics page 60521/2), for example when connecting to high rating contactors.
- (3) Insert a transformer if the line voltage is different to that defined for the control circuit (see page 60521/2).

Types of coordination

The standard defines tests for different current levels which are designed to expose the device to extreme conditions. Based on the state of the components after a short-circuit test, the standard defines 2 types of coordination.

- Type 1 coordination: Damage to the contactor and the starter is acceptable under 2 conditions:

- No risk is posed to the operator
 - Elements other than the contactor and the starter are not damaged
- Maintenance must be carried out after a short-circuit.

- Type 2 coordination: Minor soldering of the contactor contacts is permissible if they can be separated easily. The starter must not be damaged beyond repair. The protection and control devices remain operational after type 2 coordination tests. Once the fuses have been replaced, check the contactor.

Note: The starter will protect the motor and the cables against overloads. If this protection function is disabled, external thermal protection must be provided.

Recommended application diagram for non-reversing unit with starter line and bypass contactors, type 1 and type 2 coordination

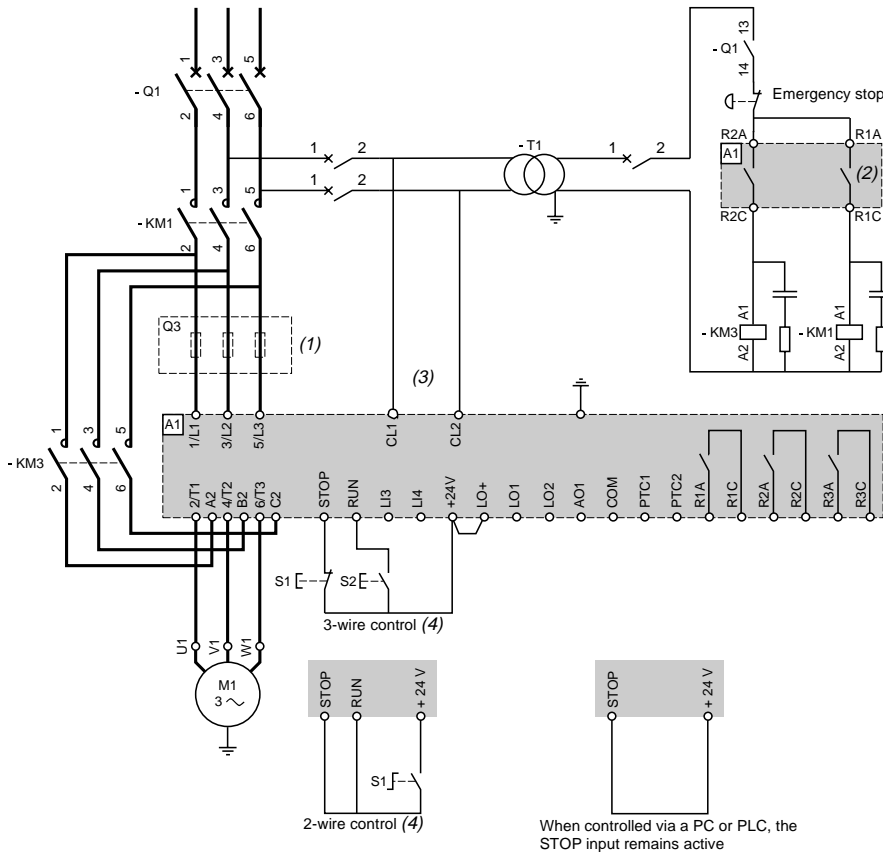

Select the components to connect, according to the descriptions below, from the association tables on pages 60525/2 to 60525/11.

- (1) For type 2 coordination (according to IEC 60947-4-2), install fast-acting fuses to ensure that the starter will be protected in the event of a short-circuit.
- (2) Assign relay R1 as the "isolating relay". Beware of the operating limits of the contacts (see Characteristics page 60521/2), for example when connecting to high rating contactors.
- (3) Insert a transformer if the line voltage is different to that defined for the control circuit (see page 60521/2).
- (4) 2-wire and 3-wire control (see page 60526/8).

Components to connect depending on the types of coordination and voltages

Designation	Description
M1	Motor
A1	Starter (standard applications and severe applications)
Q1	Circuit-breaker or switch/fuses
Q3	3 FA fuses
KM1, KM3	Contactors
S1, S2	Control (separate parts XB2 or XB2 M)

Recommended application diagram for connection to the motor delta terminals, non-reversing, freewheel stop, with starter line and bypass contactors, type 1 and type 2 coordination

This type of wiring enables the starter rating to be reduced.
ATS 48●●●Q

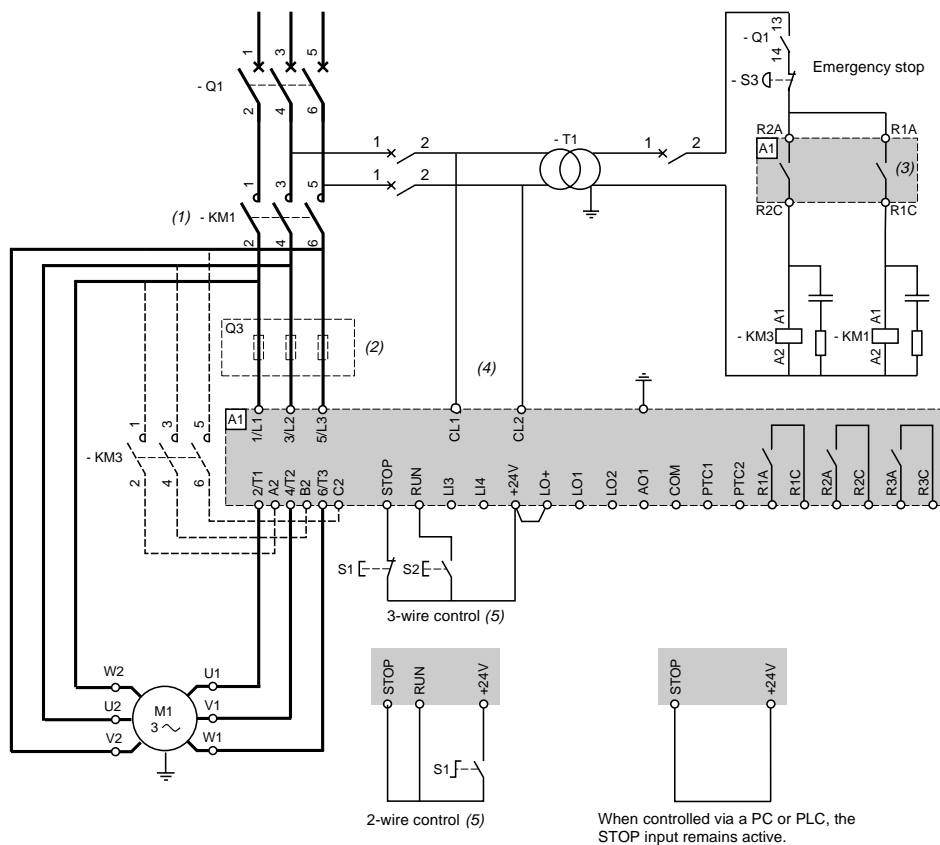

Select the components to connect according to the descriptions on page 60524/5 and the association tables on pages 60525/2 to 60525/11.

- (1) A line contactor must be used in the sequence.
- (2) For type 2 coordination (according to IEC 60947-4-2), install fast-acting fuses to ensure that the starter will be protected in the event of a short-circuit.
- (3) R1 must be assigned as the "isolating relay" to control contactor KM1. Beware of the operating limits of the contacts. (see Characteristics page 60521-2), for example when connecting to high rating contactors.
- (4) Insert a transformer if the line voltage is different to that defined for the control circuit (see page 60521/2)
- (5) 2-wire and 3-wire control (see page 60526/8).

Types of coordination

The standard defines tests for different current levels which are designed to expose the device to extreme conditions. Based on the state of the components after a short-circuit test, the standard defines 2 types of coordination.

- Type 1 coordination: damage to the contactor and the starter is acceptable under 2 conditions:

- No risk is posed to the operator
 - Elements other than the contactor and the starter are not damaged
- Maintenance must be carried out after a short-circuit.

- Type 2 coordination: Minor soldering of the contactor contacts is permissible if they can be separated easily. The starter must not be damaged beyond repair. The protection and control devices remain operational after type 2 coordination tests. Once the fuses have been replaced, check the contactor.

Note: The starter will protect the motor and the cables against overloads. If this protection function is disabled, external thermal protection must be provided.

Recommended application diagram for LSP/HSP motor, non-reversing with starter line and bypass contactors

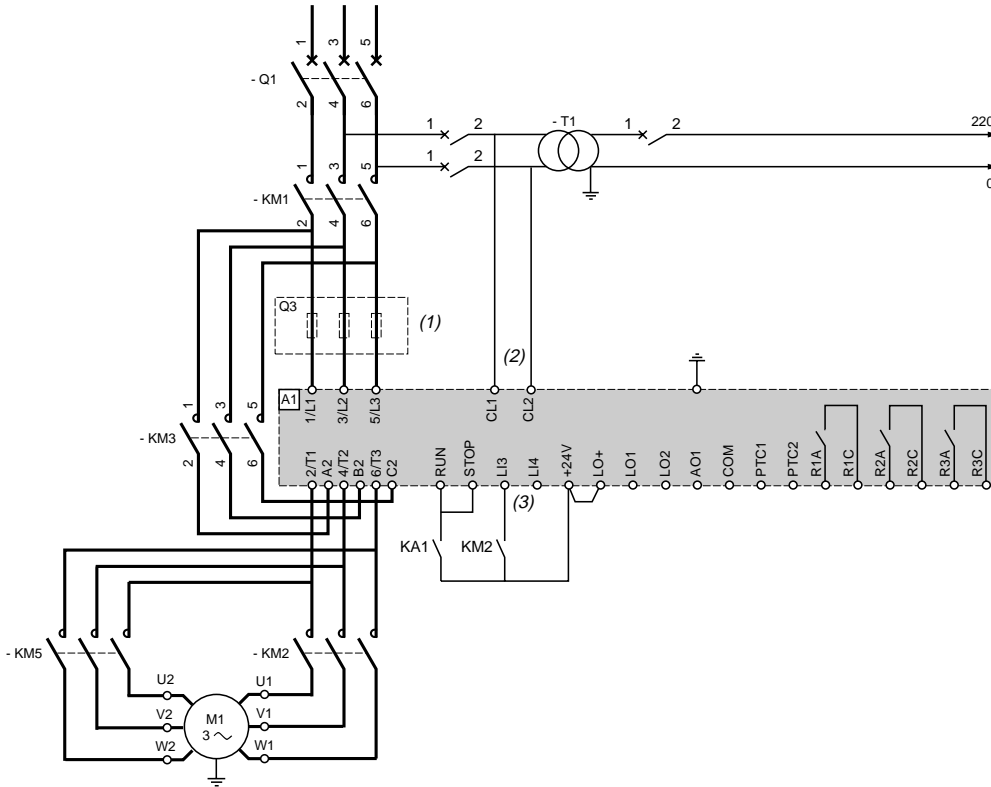

Select the components to connect, according to the descriptions below, from the association tables on pages 60525/2 to 60525/11.

- (1) For type 2 coordination (according to IEC 60947-4-2), install fast-acting fuses to ensure that the starter will be protected in the event of a short-circuit.
- (2) Insert a transformer if the line voltage is different to that defined for the control circuit (see page 60521/2).
- (3) Assign logic input LI3 to "activate the adjustment functions of the 2nd motor".
- (4) Assign relay R1 as the "isolating relay". Beware of the operating limits of the contacts (see Characteristics page 60521/2), for example when connecting to high rating contactors.

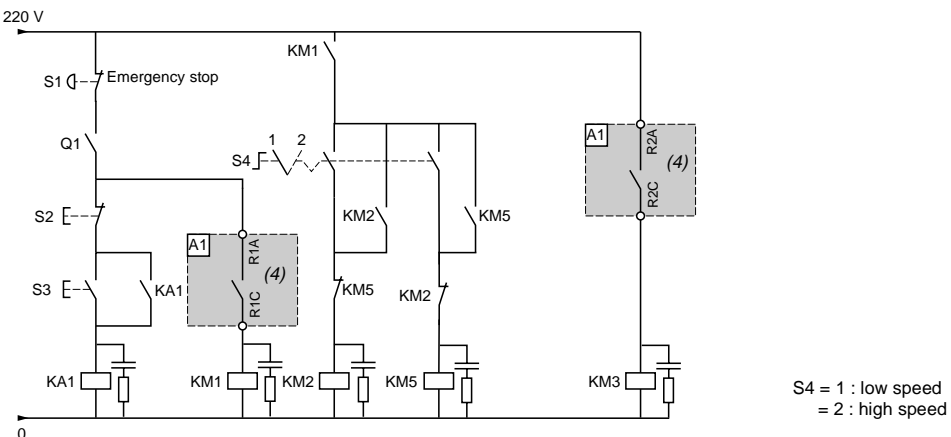

Components to connect depending on the types of coordination and voltages

Designation	Description
M1	Motor
A1	Starter (standard applications and severe applications)
Q1	Circuit-breaker or switch/fuses
Q3	3 FA fuses
KM1, KM2, KM3, KM5, KA1	Contactors and relays
S1, S2, S3	Control (separate parts XB2 or XB2 M)

Recommended application diagram for starting and decelerating several motors cascaded with a single Altistart 48, non-reversing and line contactor

The diagram is given as an example only. For more details, refer to the Altistart 48 user's manual.

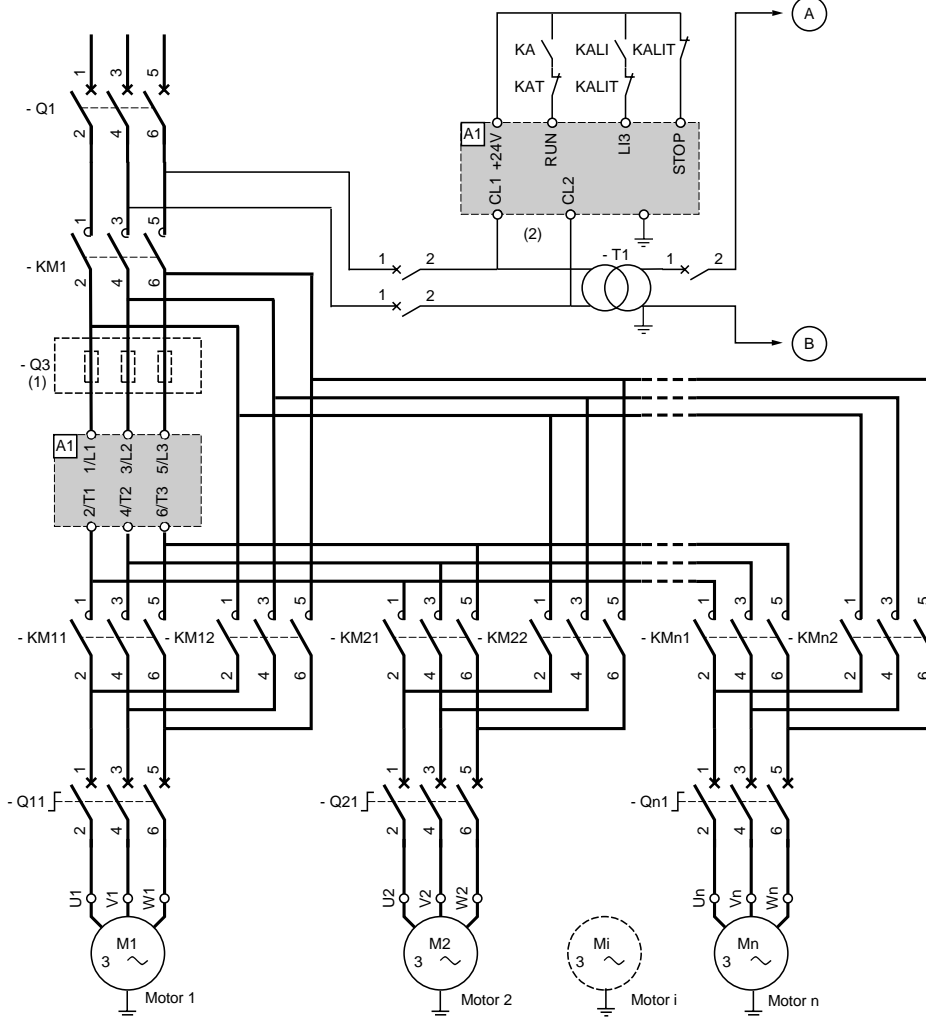

Select the components to connect, according to the designations below, from the association tables on pages 60525/2 to 60525/11.

(1) For type 2 coordination (according to IEC 60947-4-2), install fast-acting fuses to ensure that the starter will be protected in the event of a short-circuit.

(2) Insert a transformer if the line voltage is different to that defined for the control circuit (see page 60521/2).

Important:

- One Altistart 48 logic input must be configured as a "cascading" input.
- In the event of a fault, it will not be possible to decelerate or brake any motors that may be running at that time.
- Adjust the thermal protection of each circuit-breaker Q_{n1} for the corresponding nominal motor current.

Components to connect depending on the types of coordination and voltages

Designation	Description
M1, M2, Mi, Mn	Motor
A1	Starter (standard applications and severe applications)
KM1, KM2, ..., KMi, KMn	Contactors
Q1	Circuit-breaker or switch/fuses
Q3	3 FA fuses
Q11, Q21, ..., Qn1	Thermal magnetic circuit-breakers
KA, KAT, KALI, KALIT	Control (separate parts XB2 or XB2 M)

Recommended application diagram for starting and decelerating several motors cascaded with a single Altistart 48, non-reversing and line contactor (continued)

Motor n control

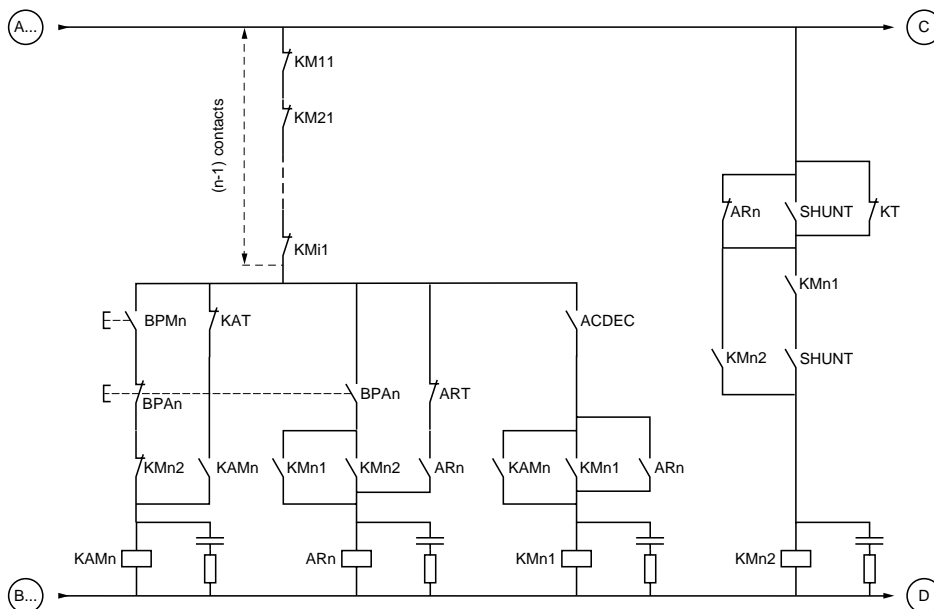

Cascade control

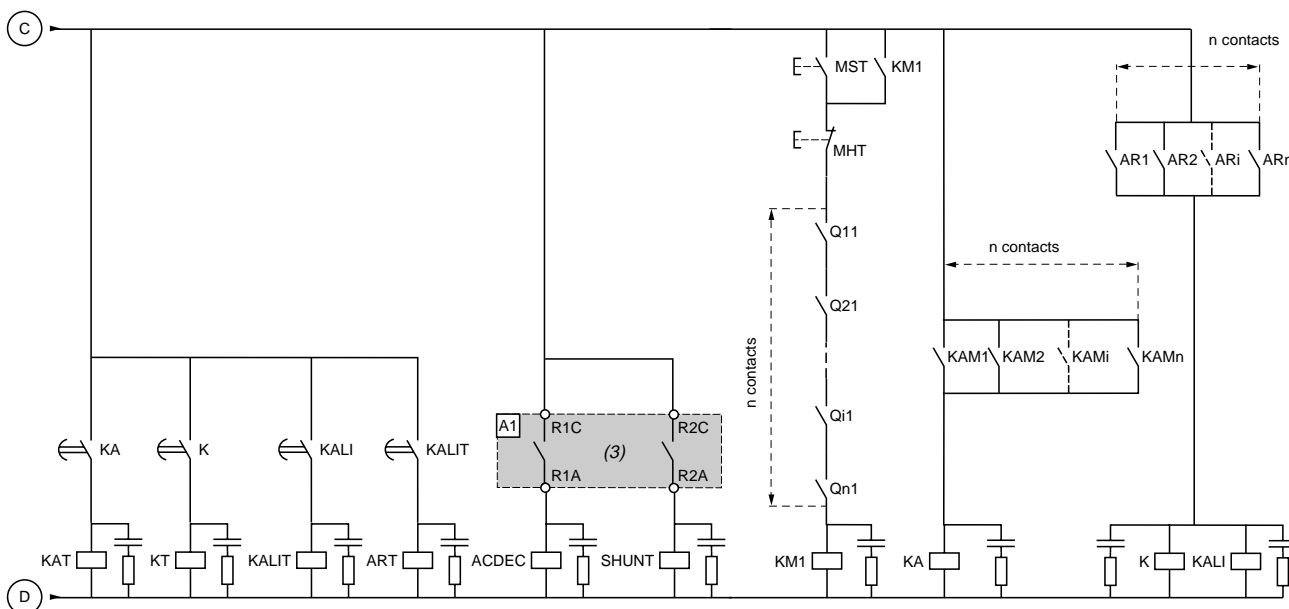

(3) Assign relay R1 as the "isolating relay". Beware of the operating limits of the contacts (see Characteristics page 60521/2), for example when connecting to high rating contactors.

- BPMn: "Run" button motor n
- BPA n: "Stop" button motor n
- MST: General "Run" button
- MHT: General "Stop" button

Soft starters

Altistart 48 soft start - soft stop units
230 V power supply
Type 1 coordination

Components for use together in accordance with standards IEC 60947-4-1 and IEC 60947-4-2 (see schemes on pages 60524/2 to 60524/7)

Combine either circuit-breaker (light blue columns), contactor, starter, or switches/fuses (dark blue columns), contactor, starter

Motor kW	A	Starter (1)		Type of circuit-breaker		Type of contactor	Type of switch or switch disconnector (bare unit)	Am fuses		Size	Rating A
		Class 10 Standard applications	Class 20 Severe applications	Telemecanique Merlin Gerin	Rating A			Reference Without striker	With striker		
M1		A1		Q1		KM1, KM2, KM3					
3	11.5	-	ATS 48D17●	GV2 L20	18	LC1 D18	LS1 D32	DF2 CA16	-	10 x 38	16
				NS80H MA	12.5	LC1 D18	LS1 D32	DF2 CA16	-	10 x 38	16
4	14.5	ATS 48D17●	ATS 48D22●	GV2 L20	18	LC1 D18	LS1 D32	DF2 CA16	-	10 x 38	16
				NS80H MA	25	LC1 D18	LS1 D32	DF2 CA16	-	10 x 38	16
5.5	20	ATS 48D22●	ATS 48D32●	GV2 L22	25	LC1 D25	LS1 D32	DF2 CA25	-	10 x 38	25
				NS80H MA	25	LC1 D25	LS1 D32	DF2 CA25	-	10 x 38	25
7.5	27	ATS 48D32●	ATS 48D38●	GV2 L32	32	LC1 D32	GK1 EK	DF2 EA32	DF3 EA32	14 x 51	32
				NS80H MA	50	LC1 D32	GK1 EK	DF2 EA32	DF3 EA32	14 x 51	32
9	32	ATS 48D38●	ATS 48D47●	GK3 EF40	40	LC1 D38	GK1 EK	DF2 EA40	DF3 EA40	14 x 51	40
				NS80H MA	50	LC1 D38	GK1 EK	DF2 EA40	DF3 EA40	14 x 51	40
11	39	ATS 48D47●	ATS 48D62●	GK3 EF65	65	LC1 D50	GK1 FK	DF2 FA50	DF3 FA50	22 x 58	50
				NS80H MA	50	LC1 D50	GK1 FK	DF2 FA50	DF3 FA50	22 x 58	50
15	52	ATS 48D62●	ATS 48D75●	GK3 EF65	65	LC1 D65	GK1 FK	DF2 FA80	DF3 FA80	22 x 58	80
				NS80H MA	80	LC1 D65	GK1 FK	DF2 FA80	DF3 FA80	22 x 58	80
18.5	64	ATS 48D75●	ATS 48D88●	GK3 EF80	80	LC1 D80	GK1 FK	DF2 FA80	DF3 FA80	22 x 58	80
				NS80H MA	80	LC1 D80	GK1 FK	DF2 FA80	DF3 FA80	22 x 58	80
22	75	ATS 48D88●	ATS 48C11●	NS100● MA (2)	100	LC1 D115	GK1 FK	DF2 FA100	DF3 FA100	22 x 58	100
30	103	ATS 48C11●	ATS 48C14●	NS160● MA (2)	150	LC1 D115	GK1 FK	DF2 FA125	DF4 FA125	22 x 58	125
37	126	ATS 48C14●	ATS 48C17●	NS160● MA (2)	150	LC1 D150	GS1 L	DF2 GA1161	DF4 GA1161	0	160
45	150	ATS 48C17●	ATS 48C21●	NS250● MA (2)	220	LC1 F185	GS1 N	DF2 HA1201	DF4 HA1201	1	200
55	182	ATS 48C21●	ATS 48C25●	NS250● MA (2)	220	LC1 F225	GS1 N	DF2 HA1201	DF4 HA1201	1	200
75	240	ATS 48C25●	ATS 48C32●	NS400● MA (2)	320	LC1 F265	GS1 QQ	DF2 JA1251	DF4 JA1251	2	250
90	295	ATS 48C32●	ATS 48C41●	NS400● MA (2)	320	LC1 F330	GS1 QQ	DF2 JA1311	DF4 JA1311	2	315
110	356	ATS 48C41●	ATS 48C48●	NS630● MA (2)	500	LC1 F400	GS1 S	DF2 KA1401	DF4 KA1401	3	400
132	425	ATS 48C48●	ATS 48C59●	NS630● MA (2)	500	LC1 F500	GS1 S	DF2 KA1501	DF4 KA1501	3	500
160	520	ATS 48C59●	ATS 48C66●	NS630b● (2) Micrologic 5.0	630	LC1 F630	GS1 S	DF2 KA1631	DF4 KA1631	3	630
				C801● (2) STR35 ME	800	LC1 F630	GS1 S	DF2 KA1631	DF4 KA1631	3	630
-	-	ATS 48C66●	ATS 48C79●	NS800● (2) Micrologic 5.0	800	LC1 F800	GS1 S	DF2 KA1631	DF4 KA1631	3	630
				C801● (2) STR35 ME	800	LC1 F800	GS1 S	DF2 KA1631	DF4 KA1631	3	630
220	700	ATS 48C79●	ATS 48M10●	NS800● (2) Micrologic 5.0	800	LC1 F800	GS1 V	DF2 LA1801	DF4 LA1801	4	800
				C801● (2) STR35 ME	800	LC1 F800	GS1 V	DF2 LA1801	DF4 LA1801	4	800
250	800	ATS 48M10●	ATS 48M12●	NS1000● (2) Micrologic 5.0	1000	LC1 BM33	GS1 V	DF2 LA1101	DF4 LA1101	4	1000
				C1001● (2) STR35 ME	1000	LC1 BM33	GS1 V	DF2 LA1101	DF4 LA1101	4	1000
355	1115	ATS 48M12●	-	NS1250● (2) Micrologic 5.0	1250	LC1BP33	-	DF2 LA1251	DF4 LA1251	4	1250
				C1251● (2) STR35 ME	1250	LC1BP33	-	DF2 LA1251	DF4 LA1251	4	1250

(1) Replace ● with Q or Y according to the starter voltage range.

(2) Replace ● with N, H or L, according to the breaking capacity (see table below).

Breaking capacity of circuit-breakers according to standard IEC 60947-2

230 V	Icu (kA)
GV2 L20, GK3 EF40, NS80	100
GV2 L22, GV2 L32, GK3 EF65, GK3 EF80	50
230 V	Icu (kA)
	N H L
NS100, NS160, NS250, NS400, NS630	85 100 150
NS800, NS1000	50 70 150
NS1250	50 70 -
C801, C1001	85 100 150
C1251	85 100 -

Maximum prospective short-circuit current of the starter according to standard IEC 60947-4-2

Starter	Iq (kA)
ATS 48D17● to ATS 48C32●	50
ATS 48C41● to ATS 48M12●	70

Soft starters

Altistart 48 soft start - soft stop units

230 V power supply

Type 2 coordination

Components for use together in accordance with standards IEC 60947-4-1 and IEC 60947-4-2 (see schemes on pages 60524/2 to 60524/7) circuit-breakers, contactors, fast-acting fuses, starters

Combination: circuit-breaker, contactor, starter

Motor		Starter (1)		Type of circuit-breaker	Rating A	Type of contactor
kW	A	Class 10 Standard applications	Class 20 Severe applications	Telemecanique Merlin Gerin		
M1		A1		Q1		KM1, KM2, KM3
3	11.5	–	ATS 48D17●	GV2 L20 NS80H MA	18 12.5	LC1 D40
4	14.5	ATS 48D17●	ATS 48D22●	GV2 L20 NS80H MA	18 25	LC1 D40
5.5	20	ATS 48-D22●	ATS 48D32●	GV2 L22 NS80H MA	25 25	LC1 D40
7.5	27	ATS 48D32●	ATS 48D38●	GV2 L32 NS80H MA	32 50	LC1 D80
9	32	ATS 48D38●	ATS 48D47●	GK3 EF40 NS80H MA	40 50	LC1 D80
11	39	ATS 48D47●	ATS 48D62●	GK3 EF65 NS80H MA	65 50	LC1 D80
15	52	ATS 48D62●	ATS 48D75●	GK3 EF65 NS80H MA	65 80	LC1 D80
18.5	64	ATS 48D75●	ATS 48D88●	GK3 EF80 NS80H MA	80 80	LC1 D80
22	75	ATS 48D88●	ATS 48C11●	NS100● MA (2)	100	LC1 D115
30	103	ATS 48C11●	ATS 48C14●	NS160● MA (2)	150	LC1 D115
37	126	ATS 48C14●	ATS 48C17●	NS160● MA (2)	150	LC1 D150
45	150	ATS 48C17●	ATS 48C21●	NS250● MA (2)	220	LC1 F185
55	182	ATS 48C21●	ATS 48C25●	NS250● MA (2)	220	LC1 F225
75	240	ATS 48C25●	ATS 48C32●	NS400● MA (2)	320	LC1 F265
90	295	ATS 48C32●	ATS 48C41●	NS400● MA (2)	320	LC1 F330
110	356	ATS 48C41●	ATS 48C48●	NS630● MA (2)	500	LC1 F400
132	425	ATS 48C48●	ATS 48C59●	NS630● MA (2)	500	LC1 F500
160	520	ATS 48C59●	ATS 48C66●	NS630bL Micrologic 5.0	630	LC1 F630
200	626	ATS 48C66●	ATS 48C79●	NS800L Micrologic 5.0	800	LC1 F800
220	700	ATS 48C79●	ATS 48M10●	NS800L Micrologic 5.0	800	LC1 F800
250	800	ATS 48M10●	ATS 48M12●	NS1000L Micrologic 5.0	1000	LC1 BM33
355	1115	ATS 48M12●	–	NS1250● (2) Micrologic 5.0 (3)	1250	LC1 BP33

(1) Replace ● with Q or Y according to the starter voltage range.

(2) Replace ● with N, H or L, according to the breaking capacity (see the breaking capacity table on the previous page).

(3) Type 2 coordination is only possible if the fast-acting fuses remain in the motor supply circuit and are not bypassed at the end of starting.

Fast-acting fuse (essential for type 2 coordination), starter combinations

Starter Reference	Fast-acting fuses		
	Reference	Size	Rating A I _t kA ² .s
A1	Q3		
ATS 48D17●	DF3 ER50	14 x 51	50 2.3
ATS 48D22● and ATS 48D32●	DF3 FR80	22 x 58	80 5.6
ATS 48D38● and ATS 48D47●	DF3 FR100	22 x 58	100 12
ATS 48D62● and ATS 48D75●	DF4 00125	00	125 45
ATS 48D88● and ATS 48C11●	DF4 00160	00	160 82
ATS 48C14● and ATS 48C17●	DF4 30400	30	400 120
ATS 48C21● to ATS 48C32●	DF4 31700	31	700 490
ATS 48D75●	DF4 33800	33	800 490
ATS 48C48● and ATS 48C59●	DF4 331000	33	1000 900
ATS 48C66●	DF4 2331400	2 x 33	1400 1200
ATS 48C79●	DF4 441600	44	1600 1600
ATS 48M10● and ATS 48M12●	DF4 442200	44	2200 4100
Maximum prospective short-circuit current of the starter according to standard IEC 60947-4-2			
Starter	I _q (kA)		
ATS 48D17● to ATS 48C79●	50		
ATS 48M10● and ATS 48M12●	85		

Soft starters

Altistart 48 soft start - soft stop units
380 V, 400 V, 415 V power supply
Type 1 coordination

Components for use together in accordance with standards IEC 60947-4-1 and IEC 60947-4-2 (see schemes on pages 60524/2 to 60524/7)

Combine either circuit-breaker (light blue columns), contactor, starter, or switches/fuses (dark blue columns), contactor, starter

Motor kW	A	Starter (1)		Type of circuit-breaker		Type of contactor	Type of switch or switch disconnecter (bare unit)	Am fuses		Size	Rating A
		Class 10 Standard applications	Class 20 Severe applications	Telemecanique Merlin Gerin	Rating A			Reference Without striker	With striker		
M1		A1		Q1		KM1, KM2, KM3					
5.5	11	-	ATS 48D17●	GV2 L20	18	LC1 D18	LS1 D32	DF2 CA16	-	10 x 38	16
				NS80H MA	12.5	LC1 D18	LS1 D32	DF2 CA16	-	10 x 38	16
7.5	14.8	ATS 48D17●	ATS 48D22●	GV2 L20	18	LC1 D18	LS1 D32	DF2 CA16	-	10 x 38	16
				NS80H MA	25	LC1 D18	LS1 D32	DF2 CA16	-	10 x 38	16
11	21	ATS 48D22●	ATS 48D32●	GV2 L22	25	LC1 D25	LS1 D32	DF2 CA25	-	10 x 38	25
				NS80H MA	25	LC1 D25	LS1 D32	DF2 CA25	-	10 x 38	25
15	28.5	ATS 48D32●	ATS 48D38●	GV2 L32	32	LC1 D32	GK1 EK	DF2 EA32	DF3 EA32	14 x 51	32
				NS80H MA	50	LC1 D32	GK1 EK	DF2 EA32	DF3 EA32	14 x 51	32
18.5	35	ATS 48D38●	ATS 48D47●	GK3 EF40	40	LC1 D38	GK1 EK	DF2 EA40	DF3 EA40	14 x 51	40
				NS80H MA	50	LC1 D38	GK1 EK	DF2 EA40	DF3 EA40	14 x 51	40
22	42	ATS 48D47●	ATS 48D62●	GK3 EF65	65	LC1 D50	GK1 FK	DF2 FA50	DF3 FA50	22 x 58	50
				NS80H MA	50	LC1 D50	GK1 FK	DF2 FA50	DF3 FA50	22 x 58	50
30	57	ATS 48D62●	ATS 48D75●	GK3 EF65	65	LC1 D65	GK1 FK	DF2 FA80	DF3 FA80	22 x 58	80
				NS80H MA	80	LC1 D65	GK1 FK	DF2 FA80	DF3 FA80	22 x 58	80
37	69	ATS 48D75●	ATS 48D88●	GK3 EF80	80	LC1 D80	GK1 FK	DF2 FA80	DF3 FA80	22 x 58	80
				NS80H MA	80	LC1 D80	GK1 FK	DF2 FA80	DF3 FA80	22 x 58	80
45	81	ATS 48D88●	ATS48C11●	NS100● MA (2)	100	LC1 D115	GK1 FK	DF2 FA100	DF3 FA100	22 x 58	100
55	100	ATS 48C11●	ATS 48C14●	NS160● MA (2)	150	LC1 D115	GK1 FK	DF2 FA125	DF4 FA125	22 x 58	125
75	131	ATS 48C14●	ATS 48C17●	NS160● MA (2)	150	LC1 D150	GS1 L	DF2 GA1161	DF4 GA1161	0	160
90	162	ATS 48C17●	ATS 48C21●	NS250● MA (2)	220	LC1 F185	GS1 N	DF2 HA1201	DF4 HA1201	1	200
110	195	ATS 48C21●	ATS 48C25●	NS250● MA (2)	220	LC1 F225	GS1 N	DF2 HA1201	DF4 HA1201	1	200
132	233	ATS 48C25●	ATS 48C32●	NS400● MA (2)	320	LC1 F265	GS1 QQ	DF2 JA1251	DF4 JA1251	2	250
160	285	ATS 48C32●	ATS 48C41●	NS400● MA (2)	320	LC1 F330	GS1 QQ	DF2 JA1311	DF4 JA1311	2	315
220	388	ATS 48C41●	ATS 48C48●	NS630● MA (2)	500	LC1 F400	GS1 S	DF2 KA1401	DF4 KA1401	3	400
250	437	ATS 48C48●	ATS 48C59●	NS630● MA (2)	500	LC1 F500	GS1 S	DF2 KA1501	DF4 KA1501	3	500
315	560	ATS 48C59●	ATS 48C66●	NS630b● (2) Micrologic 5.0	630	LC1 F630	GS1 S	DF2 KA1631	DF4 KA1631	3	630
				C801● (2) STR35ME	800	LC1 F630	GS1 S	DF2 KA1631	DF4 KA1631	3	630
355	605	ATS 48C66●	ATS 48C79●	NS800● (2) Micrologic 5.0	800	LC1 F800	GS1 V	DF2 LA1631	DF4 LA1631	4	630
				C801● (2) STR35ME	800	LC1 F800	GS1 V	DF2 LA1631	DF4 LA1631	4	630
400	675	ATS 48C79●	ATS 48M10●	NS800● (2) Micrologic 5.0	800	LC1 F800	GS1 V	DF2 LA1801	DF4 LA1801	4	800
				C801● (2) STR35ME	800	LC1 F800	GS1 V	DF2 LA1801	DF4 LA1801	4	800
500	855	ATS 48M10●	ATS 48M12●	NS1000● (2) Micrologic 5.0	1000	LC1 BM33	GS1 V	DF2 LA1101	DF4 LA1101	4	1000
				C1001● (2) STR35ME	1000	LC1 BM33	GS1 V	DF2 LA1101	DF4 LA1101	4	1000
630	1045	ATS48M12●	-	NS1250● (2) Micrologic 5.0	1250	LC1 BP33	-	DF2 LA1251	DF4 LA1251	4	1250
				C1251● (2) STR35ME	1250	LC1 BP33	-	DF2 LA1251	DF4 LA1251	4	1250

(1) Replace ● with Q or Y according to the starter voltage range.
(2) Replace ● with N, H or L, according to the breaking capacity (see table below).

Maximum prospective short-circuit current of the starter according to IEC 60947-4-2	Iq (kA)	Breaking capacity of circuit-breakers according to standard IEC 60947-2			
		380 V, 400 V, 415 V			
Starter	Iq (kA)	Icu (kA)			
ATS 48D17● to ATS 48C32●	50	GV2 L20, GV2 L22, GV2 L32	50		
ATS 48C41● to ATS 48M12●	70	GK3 EF40	50		
		GK3 EF65, GK3 EF80	35		
		NS80	70		
		380 V, 400 V, 415 V	Icu (kA)		
			N	H	L
		NS100	25	70	150
		NS160, NS250	36	70	150
		NS400, NS630	45	70	150
		NS800, NS1000	50	70	150
		NS1250	50	70	-
		C801, C1001	50	70	150
		C1251	50	70	-

Presentation: pages 60520/2 to 60520/3 Characteristics: pages 60521/2 to 60521/5 References: pages 60522/2 to 60522/5 Dimensions: pages 60523/2 to 60523/5 Schemes: pages 60524/2 to 60524/7

Soft starters

Altistart 48 soft start - soft stop units

380 V, 400 V, 415 V power supply

Type 2 coordination

Components for use together in accordance with standards IEC 60947-4-1 and IEC 60947-4-2 (see schemes on pages 60524/2 to 60524/7) circuit-breakers, contactors, fast-acting fuses, starters

Combination: circuit-breaker, contactor, starter

Motor		Starter (1)		Type of circuit-breaker	Rating	Type of contactor
kW	A	Class 10	Class 20	Telemecanique Merlin Gerin	A	
		Standard applications	Severe applications			
M1		A1		Q1		KM1, KM2, KM3
5.5	11	-	ATS 48D17●	GV2 L20	18	LC1 D40
				NS80H MA	12.5	LC1 D40
7.5	14.8	ATS 48D17●	ATS 48D22●	GV2 L20	18	LC1 D40
				NS80H MA	25	LC1 D40
11	21	ATS 48D22●	ATS 48D32●	GV2 L22	25	LC1 D40
				NS80H MA	25	LC1 D40
15	28.5	ATS 48D32●	ATS 48D38●	GV2 L32	32	LC1 D80
				NS80H MA	50	LC1 D80
18.5	35	ATS 48D38●	ATS 48D47●	NS80H MA	50	LC1 D80
22	42	ATS 48D47●	ATS 48D62●	NS80H MA	50	LC1 D80
30	57	ATS 48D62●	ATS 48D75●	NS80H MA	80	LC1 D80
37	69	ATS 48D75●	ATS 48D88●	NS80H MA	80	LC1 D80
45	81	ATS 48D88●	ATS 48C11●	NS100● MA (2)	100	LC1 D115
55	100	ATS 48C11●	ATS 48C14●	NS160● MA (2)	150	LC1 D115
75	131	ATS 48C14●	ATS 48C17●	NS160● MA (2)	150	LC1 D150
90	162	ATS 48C17●	ATS 48C21●	NS 250● MA (2)	220	LC1 F185
110	195	ATS 48C21●	ATS 48C25●	NS 250● MA (2)	220	LC1 F225
132	233	ATS 48C25●	ATS 48C32●	NS400● MA (2)	320	LC1 F265
160	285	ATS 48C32●	ATS 48C41●	NS400● MA (2)	320	LC1 F330
220	388	ATS 48C41●	ATS 48C48●	NS630● MA (2)	500	LC1 F500
250	437	ATS 48C48●	ATS 48C59●	NS630● MA (2)	500	LC1 F500
315	560	ATS 48C59●	ATS 48C66●	NS630bL Micrologic 5.0	630	LC1 F630
355	605	ATS48C66●	ATS48C79●	NS800L Micrologic 5.0	800	LC1 F800
400	675	ATS48C79●	ATS48M10●	NS800L Micrologic 5.0	800	LC1 F800
500	855	ATS48M10●	ATS48M12●	NS1000L Micrologic 5.0	1000	LC1 BM33
630	1045	ATS48M12●	-	NS1250● (2) Micrologic 5.0 (3)	1250	LC1 BP33

(1) Replace ● with Q or Y according to the starter voltage range.

(2) Replace ● with N, H or L, according to the breaking capacity (see the breaking capacity table on the previous page).

(3) Type 2 coordination is only possible if the fast-acting fuses remain in the motor supply circuit and are not bypassed at the end of starting.

Fast-acting fuse (essential for type 2 coordination), starter combinations

Starter Reference	Fast-acting fuses			
	Reference	Size	Rating A	I _{pt} kA ² .s
A1	Q3			
ATS 48D17●	DF3 ER50	14 x 51	50	2.3
ATS 48D22● and ATS 48D32●	DF3 FR80	22 x 58	80	5.6
ATS 48D38● and ATS 48D47●	DF3 FR100	22 x 58	100	12
ATS 48D62● and ATS 48D75●	DF4 00125	00	125	45
ATS 48D88● and ATS 48C11●	DF4 00160	00	160	82
ATS 48C14● and ATS 48C17●	DF4 30400	30	400	120
ATS 48C21● to ATS 48C32●	DF4 31700	31	700	490
ATS 48D75●	DF4 33800	33	800	490
ATS 48C48● and ATS 48C59●	DF4 331000	33	1000	900
ATS 48C66●	DF4 2331400	2 x 33	1400	1200
ATS 48C79●	DF4 441600	44	1600	1600
ATS 48M10● and ATS 48M12●	DF4 442200	44	2200	4100

Maximum prospective short-circuit current of the starter according to standard IEC 60947-4-2

Starter	I _q (kA)
ATS 48D17●	50
ATS 48D22● to ATS 48D47●	40
ATS 48D62● to ATS 48C79●	50
ATS 48M10● and ATS 48M12●	85

Soft starters

Altistart 48 soft start - soft stop units

440 V power supply

Type 1 coordination

Components for use together in accordance with standards IEC 60947-4-1 and IEC 60947-4-2 (see schemes on pages 60524/2 to 60524/7)

Combine either circuit-breaker (light blue columns), contactor, starter, or switches/fuses (dark blue columns), contactor, starter

Motor kW	A	Starter		Type of circuit-breaker		Type of contactor	Type of switch or switch disconnecter (bare unit)	Am fuses		Size	Rating A
		Class 10 Standard applications	Class 20 Severe applications	Telemecanique <i>Merlin Gerin</i>	Rating A			Reference Without striker	With striker		
M1		A1		Q1		KM1, KM2, KM3					
5.5	10.4	-	ATS 48D17Y	NS100● MA (1) NS80H MA	12.5	LC1 D12	LS1 D32	DF2 CA16	-	10 x 38	16
7.5	13.7	ATS 48D17Y	ATS 48D22Y	NS100● MA (1) NS80H MA	25	LC1 D18	LS1 D32	DF2 CA16	-	10 x 38	16
11	20.1	ATS 48D22Y	ATS 48D32Y	NS100● MA (1) NS80H MA	25	LC1 D25	GK1 EK	DF2 EA25	DF3 EA25	14 x 51	25
15	26.5	ATS 48D32Y	ATS 48D38Y	NS100● MA (1) NS80H MA	50	LC1 D32	GK1 EK	DF2 EA32	DF3 EA32	14 x 51	32
18.5	32.8	ATS 48D38Y	ATS 48D47Y	NS100● MA (1) NS80H MA	50	LC1 D40	GK1 EK	DF2 EA40	DF3 EA40	14 x 51	40
22	39	ATS 48D47Y	ATS 48D62Y	NS100● MA (1) NS80H MA	50	LC1 D40	GK1 FK	DF2 FA50	DF3 FA50	22 x 58	50
30	52	ATS 48D62Y	ATS 48D75Y	NS80H MA	80	LC1 D65	GK1 FK	DF2 FA80	DF3 FA80	22 x 58	80
37	64	ATS 48D75Y	ATS 48D88Y	NS80H MA	80	LC1 D65	GK1 FK	DF2 FA80	DF3 FA80	22 x 58	80
45	76	ATS 48D88Y	ATS 48C11Y	NS100● MA (1)	100	LC1 D115	GK1 FK	DF2 FA100	DF3 FA100	22 x 58	100
55	90	ATS 48C11Y	ATS 48C14Y	NS100● MA (1)	100	LC1 D115	GS1 L	DF2 GA1121	DF4 GA1121	0	125
75	125	ATS 48C14Y	ATS 48C17Y	NS160● MA (1)	150	LC1 D150	GS1 L	DF2 GA1161	DF4 GA1161	1	160
90	150	ATS 48C17Y	ATS 48C21Y	NS250● MA (1)	220	LC1 F185	GS1 N	DF2 HA1201	DF4 HA1201	1	200
110	178	ATS 48C21Y	ATS 48C25Y	NS250● MA (1)	220	LC1 F225	GS1 N	DF2 HA1251	DF4 HA1251	1	250
132	215	ATS 48C25Y	ATS 48C32Y	NS250● MA (1)	220	LC1 F265	GS1 QQ	DF2 JA1311	DF4 JA1311	2	315
160	256	ATS 48C32Y	ATS 48C41Y	NS400● MA (1)	320	LC1 F265	GS1 QQ	DF2 JA1401	DF4 JA1401	2	315
220	353	ATS 48C41Y	ATS 48C48Y	NS630● MA (1)	500	LC1 F400	GS1 S	DF2 KA1501	DF4 KA1501	3	500
250	401	ATS 48C48Y	ATS 48C59Y	NS630● MA (1)	500	LC1 F400	GS1 S	DF2 KA1501	DF4 KA1501	3	500
355	549	ATS 48C59Y	ATS 48C66Y	NS630b● (1) Micrologic 5.0	630	LC1 F630	GS1 V	DF2 LA1801	DF4 LA1801	4	800
400	611	ATS 48C66Y	ATS 48C79Y	NS630b● (1) Micrologic 5.0	630	LC1 F630	GS1 V	DF2 LA1801	DF4 LA1801	4	800
500	780	ATS 48C79Y	ATS 48M10Y	NS800● (1) Micrologic 5.0	800	LC1 BM33	GS1 V	DF2 LA1801	DF4 LA1801	4	800
				C801● (1) STR35ME	800	LC1 BM33	GS1 V	DF2 LA1801	DF4 LA1801	4	800
630	965	ATS 48M10Y	ATS 48M12Y	NS1000● (1) Micrologic 5.0	1000	LC1 BP33	GS1 V	DF2 LA1101	DF4 LA1101	4	1000
				C1001L STR35ME	1000	LC1 BP33	GS1 V	DF2 LA1101	DF4 LA1101	4	1000
710	1075	ATS 48M12Y	-	NS1250● (1) Micrologic 5.0	1250	LC1 BP33	-	DF2 LA1251	-	4	1250
				C1251● (1) STR35ME	1250	LC1 BP33	-	DF2 LA1251	-	4	1250

(1) Replace ● with N, H or L, according to the breaking capacity (see table below).

Breaking capacity of circuit-breakers according to standard IEC 60947-2

440 V	Icu (kA)
GV2 L20, GV2 L22, GV2 L32	20
GK3 EF40	30
GK3 EF65, GK3 EF80	25
NS80	65
440 V	Icu (kA)
	N H L
NS100	25 65 130
NS160, NS250	35 65 130
NS400, NS630	42 65 130
NS800, NS1000	50 65 130
NS1250	50 65 -
C801, C1001	42 65 150
C1251	42 65 -

Maximum prospective short-circuit current of the starter according to standard IEC 60947-4-2

Starter	Iq (kA)
ATS 48D17Y and ATS 48C32Y	50
ATS 48C41Y to ATS 48M12Y	70

Soft starters

Altistart 48 soft start - soft stop units

440 V power supply

Type 2 coordination

Components for use together in accordance with standards IEC 60947-4-1 and IEC 60947-4-2 (see schemes on pages 60524/2 to 60524/7) circuit-breakers, contactors, fast-acting fuses, starters

Combination: circuit-breaker, contactor, starter

Motor		Starter		Type of circuit-breaker	Rating	Type of contactor
kW	A	Class 10	Class 20	Telemecanique Merlin Gerin	A	
		Standard applications	Severe applications			
M1		A1		Q1		KM1, KM2, KM3
5.5	10.4	-	ATS 48D17Y	NS80H-MA	12.5	LC1 D40
				NS100 MA (1)	12.5	LC1 D80
7.5	13.7	ATS 48D17Y	ATS 48D22Y	NS80H-MA	25	LC1 D40
				NS100 MA (1)	25	LC1 D80
11	20.1	ATS 48D22Y	ATS 48D32Y	NS80H-MA	25	LC1 D40
				NS100 MA (1)	25	LC1 D80
15	26.5	ATS 48D32Y	ATS 48D38Y	NS100 MA (1) NS80H-MA	50	LC1 D80
18.5	32.8	ATS 48D38Y	ATS 48D47Y	NS100 MA (1) NS80H MA	50	LC1 D80
22	39	ATS 48D47Y	ATS 48D62Y	NS100 MA (1) NS80H MA	50	LC1 D80
30	52	ATS 48D62Y	ATS 48D75Y	NS100 MA (1)	100	LC1 D80
				NS80H MA	80	LC1 D80
37	64	ATS 48D75Y	ATS 48D88Y	NS100 MA (1)	100	LC1 D80
				NS80H MA	80	LC1 D80
45	76	ATS 48D88Y	ATS 48C11Y	NS100 MA (1)	100	LC1 D115
55	90	ATS 48C11Y	ATS 48C14Y	NS100 MA (1)	100	LC1 D115
75	125	ATS 48C14Y	ATS 48C17Y	NS160 MA (1)	150	LC1 D150
90	150	ATS 48C17Y	ATS 48C21Y	NS160 MA (1)	150	LC1 D150
110	178	ATS 48C21Y	ATS 48C25Y	NS250 MA (1)	220	LC1 F185
132	215	ATS 48C25Y	ATS 48C32Y	NS400 MA (1)	320	LC1 F265
160	256	ATS 48C32Y	ATS 48C41Y	NS400 MA (1)	320	LC1 F265
220	353	ATS 48C41Y	ATS 48C48Y	NS630 MA (1)	500	LC1 F400
250	401	ATS 48C48Y	ATS 48C59Y	NS630 MA (1)	500	LC1 F500
355	549	ATS 48C59Y	ATS 48C66Y	NS630bL Micrologic 5.0	630	LC1 F630
400	611	ATS 48C66Y	ATS 48C79Y	NS800L Micrologic 5.0	800	LC1 F800
500	780	ATS 48C79Y	ATS 48M10Y	NS800L Micrologic 5.0	800	LC1 F800
630	965	ATS 48M10Y	ATS 48M12Y	NS1000L Micrologic 5.0	1000	LC1 BP33
710	1075	ATS 48M12Y	-	NS1250 (1) Micrologic 5.0 (2)	1250	LC1 BP33

(1) Replace ● with N, H or L, according to the breaking capacity (see the breaking capacity table on the previous page).

(2) Type 2 coordination is only possible if the fast-acting fuses remain in the motor supply circuit and are not bypassed at the end of starting.

Fast-acting fuse (essential for type 2 coordination), starter combinations

Starter Reference	Fast-acting fuses Reference	Size	Rating A	I _t kA ² .s
A1	Q3			
ATS 48D17Y	DF3 ER50	14 x 51	50	2.3
ATS 48D22Y and ATS 48D32Y	DF3 FR80	22 x 58	80	5.6
ATS 48D38Y and ATS 48D47Y	DF3 FR100	22 x 58	100	12
ATS 48D62Y and ATS 48D75Y	DF4 00125	00	125	45
ATS 48D88Y and ATS 48C11Y	DF4 00160	00	160	82
ATS 48C14Y and ATS 48C17Y	DF4 30400	30	400	120
ATS 48C21Y to ATS 48C32Y	DF4 31700	31	700	490
ATS 48C41Y	DF4 33800	33	800	490
ATS 48C48Y and ATS 48C59Y	DF4 331000	33	1000	900
ATS 48C66Y	DF4 2331400	2 x 33	1400	1200
ATS 48C79Y	DF4 441600	44	1600	1600
ATS 48M10Y and ATS 48M12Y	DF4 442200	44	2200	4100

Maximum prospective short-circuit current of the starter according to standard IEC 60947-4-2

Starter	I _q (kA)
ATS 48D17Y	50
ATS 48D22Y to ATS 48D47Y	20
ATS 48D62Y and ATS 48D75Y	50
ATS 48D88Y	40
ATS 48C11Y to ATS 48C32Y	50
ATS 48C41Y	40
ATS 48C48Y to ATS 48C79Y	50
ATS 48M10Y and ATS 48M12Y	85

Soft starters

Altistart 48 soft start - soft stop units

500 V power supply

Type 1 coordination

Components for use together in accordance with standards IEC 60947-4-1 and IEC 60947-4-2 (see schemes on pages 60524/2 to 60524/7)

Combine either circuit-breaker (light blue columns), contactor, starter, or switches/fuses (dark blue columns), contactor, starter

Motor kW	A	Starter		Type of circuit-breaker		Type of contactor	Type of switch or switch disconnecter (bare unit)	Am fuses		Size	Rating A
		Class 10 Standard applications	Class 20 Severe applications	Telemecanique Merlin Gerin	Rating A			Reference Without striker	With striker		
M1		A1		Q1		KM1, KM2, KM3					
7.5	12	–	ATS 48D17Y	NS100● MA (1) NS80H MA	12.5	LC1 D12	LS1 D32	DF2 CA16	–	10 x 38	16
9	14	ATS 48D17Y	ATS 48D22Y	NS100● MA (1) NS80H MA	25	LC1 D18	LS1 D32	DF2 CA16	–	10 x 38	16
11	18.4	ATS 48D22Y	ATS 48D32Y	NS100● MA (1) NS80H MA	25	LC1 D25	GK1 EK	DF2 EA25	DF3 EA25	14 x 51	25
18.5	28.5	ATS 48D32Y	ATS 48D38Y	NS100● MA (1) NS80H MA	50	LC1 D32	GK1 EK	DF2EA32	DF3 EA32	14 x 51	32
22	33	ATS 48D38Y	ATS 48D47Y	NS100● MA (1) NS80H MA	50	LC1 D40	GK1 EK	DF2 EA40	DF3 EA40	14 x 51	40
30	45	ATS 48D47Y	ATS 48D62Y	NS100● MA (1) NS80H MA	50	LC1 D50	GK1 FK	DF2 FA50	DF3 FA50	22 x 58	50
37	55	ATS 48D62Y	ATS 48D75Y	NS100● MA (1)	100	LC1 D65	GK1 FK	DF2 FA80	DF3 FA80	22 x 58	80
45	65	ATS 48D75Y	ATS 48D88Y	NS100● MA (1)	100	LC1 D80	GK1 FK	DF2 FA80	DF3 FA80	22 x 58	80
55	80	ATS 48D88Y	ATS 48C11Y	NS100● MA (1)	100	LC1 D80	GK1 FK	DF2 FA100	DF3 FA100	22 x 58	100
75	105	ATS 48C11Y	ATS 48C14Y	NS160● MA (1)	150	LC1 D115	GS1 L	DF2 GA1121	DF4 GA1121	0	125
90	130	ATS 48C14Y	ATS 48C17Y	NS160● MA (1)	150	LC1 D150	GS1 L	DF2 GA1161	DF4 GA1161	0	160
110	156	ATS 48C17Y	ATS 48C21Y	NS250● MA (1)	220	LC1 F185	GS1 N	DF2 HA1201	DF4 HA1201	1	200
132	207	ATS 48C21Y	ATS 48C25Y	NS250● MA (1)	220	LC1 F265	GS1 N	DF2 HA1251	DF4HA1251	1	250
160	257	ATS 48C25Y	ATS 48C32Y	NS400● MA (1)	320	LC1 F265	GS1 QQ	DF2 JA1311	DF4 JA1311	2	315
220	310	ATS 48C32Y	ATS 48C41Y	NS630● MA (1)	500	LC1 F400	GS1 QQ	DF2 JA1401	DF4 JA1401	2	400
250	360	ATS 48C41Y	ATS 48C48Y	NS630● MA (1)	500	LC1 F400	GS1 S	DF2 KA1501	DF4 KA1501	3	500
315	460	ATS 48C48Y	ATS 48C59Y	NS630● MA (1)	500	LC1 F500	GS1 S	DF2 KA1631	DF4 KA1631	3	630
400	540	ATS 48C59Y	ATS 48C66Y	NS630● (1) Micrologic 5.0	630	LC1 F630	GS1 V	DF2 LA1801	DF4 LA1801	4	800
450	630	ATS 48C66Y	ATS 48C79Y	NS630● (1) Micrologic 5.0	630	LC1 F800	GS1 V	DF2 LA1801	DF4 LA1801	4	800
500	680	ATS 48C79Y	ATS 48M10Y	NS800● MA (1) Micrologic 5.0	800	LC1 BL33	GS1 V	DF2 LA1801	DF4 LA1801	4	800
				C1001● (1) STR35 ME	1000	LC1 BL33	GS1 V	DF2 LA1801	DF4 LA1801	4	800
630	850	ATS 48M10Y	ATS 48M12Y	NS1000● (1) Micrologic 5.0	1000	LC1 BP33	GS1 V	DF2 LA1101	DF4 LA1101	4	1000
				C1001● (1) STR35 ME	1000	LC1 BP33	GS1 V	DF2 LA1101	DF4 LA1101	4	1000
800	1100	ATS 48M12Y	–	NS1250● (1) Micrologic 5.0	1250	LC1 BP33	–	DF2 LA1251	–	4	1250
				C1251● (1) STR35 ME	1250	LC1 BP33	–	DF2 LA1251	–	4	1250

(3) Replace ● with N, H or L, according to the breaking capacity (see table below).

Breaking capacity of circuit-breakers according to standard IEC 60947-2

500 V	Icu (kA)
GV2 L20, GV2 L22, GV2 L32	10
GK3 EF40	20
GK3 EF65, GK3 EF80	15
NS80	25
500 V	Icu (kA)
	N H L
NS100	18 50 100
NS160, NS250, NS630	30 50 70
NS400	30 50 100
NS800, NS1000	40 50 100
NS1250	40 50 –
C801, C1001	40 50 100
C1251	40 50 –

Maximum prospective short-circuit current of the starter according to standard IEC 60947-4-2

Starter	Iq (kA)
ATS 48D17Y to ATS 48C32Y	50
ATS 48C41Y to ATS 48M12Y	70

Soft starters

Altistart 48 soft start - soft stop units

500 V power supply

Type 2 coordination

Components for use together in accordance with standards IEC 60947-4-1 and IEC 60947-4-2 (see schemes on pages 60524/2 to 60524/7) circuit-breakers, contactors, fast-acting fuses, starters

Combination: circuit-breaker, contactor, starter

Motor		Starter		Type of circuit-breaker	Rating	Type of contactor
kW	A	Class 10	Class 20	Telemecanique Merlin Gerin	A	
		Standard applications	Severe applications			
M1		A1		Q1		KM1, KM2, KM3
7.5	12	-	ATS 48D17Y	NS80H MA	12.5	LC1 D40
				NS100● MA (1)	12.5	LC1 D80
9	14	ATS 48D17Y	ATS 48D22Y	NS80H MA	25	LC1 D40
				NS100● MA (1)	25	LC1 D80
11	18.4	ATS 48D22Y	ATS 48D32Y	NS80H MA	25	LC1 D40
				NS100● MA (1)	25	LC1 D80
18.5	28.5	ATS 48D32Y	ATS 48D38Y	NS100● MA (1) NS80H MA	50	LC1 D80
22	33	ATS 48D38Y	ATS 48D47Y	NS100● MA (1) NS80H MA	50	LC1 D80
30	45	ATS 48D47Y	ATS 48D62Y	NS100● MA (1) NS80H MA	50	LC1 D80
37	55	ATS 48D62Y	ATS 48D75Y	NS100● MA (1)	100	LC1 D80
45	65	ATS 48D75Y	ATS 48D88Y	NS100● MA (1)	100	LC1 D80
55	80	ATS 48D88Y	ATS 48C11Y	NS100● MA (1)	100	LC1 D115
75	105	ATS 48C11Y	ATS 48C14Y	NS160● MA (1)	150	LC1 D115
90	130	ATS 48C14Y	ATS 48C17Y	NS160● MA (1)	150	LC1 D150
110	156	ATS 48C17Y	ATS 48C21Y	NS250● MA (1)	220	LC1 F185
132	207	ATS 48C21Y	ATS 48C25Y	NS250● MA (1)	220	LC1 F265
160	257	ATS 48C25Y	ATS 48C32Y	NS400● MA (1)	320	LC1 F400
220	310	ATS 48C32Y	ATS 48C41Y	NS400● MA (1)	320	LC1 F400
250	360	ATS 48C41Y	ATS 48C48Y	NS630● MA (1)	500	LC1 F500
315	460	ATS 48C48Y	ATS 48C59Y	NS630● MA (1)	500	LC1 F500
400	540	ATS 48C59Y	ATS 48C66Y	NS630bL Micrologic 5.0	630	LC1 F630
450	630	ATS 48C66Y	ATS 48C79Y	NS630bL Micrologic 5.0	630	LC1 F800
500	680	ATS 48C79Y	ATS 48M10Y	NS800L Micrologic 5.0	800	LC1 BL33
630	850	ATS 48M10Y	ATS 48M12Y	NS1000L Micrologic 5.0	1000	LC1 BP33
800	1100	ATS 48M12Y	-	NS1250● (1) Micrologic 5.0 (2)	1250	LC1 BP33

(1) Replace ● with N, H or L, according to the breaking capacity (see the breaking capacity table on the previous page).

(2) Type 2 coordination is only possible if the fast-acting fuses remain in the motor supply circuit and are not bypassed at the end of starting.

Fast-acting fuse (essential for type 2 coordination), starter combinations

Starter Reference	Fast-acting fuses Reference	Size	Rating	I ² t kA ² .s
			A	
A1	Q3			
ATS 48D17Y	DF3 ER50	14 x 51	50	2.3
ATS 48D22Y and ATS 48D32Y	DF3 FR80	22 x 58	80	5.6
ATS 48D38Y and ATS 48D47Y	DF3 FR100	22 x 58	100	12
ATS 48D62Y and ATS 48D75Y	DF4 00125	00	125	45
ATS 48D88Y and ATS 48C11Y	DF4 00160	00	160	82
ATS 48C14Y and ATS 48C17Y	DF4 30400	30	400	120
ATS 48C21Y to ATS 48C32Y	DF4 31700	31	700	490
ATS 48C41Y	DF4 33800	33	800	490
ATS 48C48Y and ATS 48C59Y	DF4 331000	33	1000	900
ATS 48C66Y	DF4 2331400	2 x 33	1400	1200
ATS 48C79Y	DF4 441600	44	1600	1600
ATS 48M10Y and ATS 48M12Y	DF4 442200	44	2200	4100

Maximum prospective short-circuit current of the starter according to standard IEC 60947-4-2

Starter	I _q (kA)
ATS 48D17Y	50
ATS 48D22Y to ATS 48D47Y	20
ATS 48D62Y and ATS 48D75Y	50
ATS 48D88Y	40
ATS 48C11Y to ATS 48C32Y	50
ATS 48C41Y	40
ATS 48C48Y to ATS 48C79Y	50
ATS 48M10Y and ATS 48M12Y	85

Soft starters

Altistart 48 soft start - soft stop units

690 V power supply

Type 1 coordination

Components for use together in accordance with standards IEC 60947-4-1 and IEC 60947-4-2 (see schemes on pages 60524/2 to 60524/7)

Combine either circuit-breaker (light blue columns), contactor, starter, or switches/fuses (dark blue columns), contactor, starter

Motor kW	A	Starter		Type of circuit-breaker		Type of contactor	Type of switch or switch disconnecter (bare unit)	Am fuses		Size	Rating A
		Class 10 Standard applications	Class 20 Severe applications	Telemecanique Merlin Gerin	Rating A			Reference Without striker	With striker		
M1		A1		Q1		KM1, KM2, KM3					
11	12.1	–	ATS 48D17Y	NS100● MA (1) NS80H MA	12.5 12.5	LC1 D18	GK1 FK	DF2 FA16	DF3 FA16	22 x 58	16
15	16.5	ATS 48D17Y	ATS 48D22Y	NS100● MA (1) NS80H MA	25 25	LC1 D25	GK1 FK	DF2 FA20	DF3 FA20	22 x 58	20
18.5	20.2	ATS 48D22Y	ATS 48D32Y	NS100● MA (1) NS80H MA	50 50	LC1 D32	GK1 FK	DF2 FA25	DF3 FA25	22 x 58	25
22	24.2	ATS 48D32Y	ATS 48D38Y	NS100● MA (1) NS80H MA	50 50	LC1 D40	GK1 FK	DF2 FA32	DF3 FA32	22 x 58	32
30	33	ATS 48D38Y	ATS 48D47Y	NS100● MA (1) NS80H MA	50 50	LC1 D40	GK1 FK	DF2 FA40	DF3 FA40	22 x 58	40
37	40	ATS 48D47Y	ATS 48D62Y	NS100● MA (1) NS80H MA	50 50	LC1 D65	GK1 FK	DF2 FA50	DF3 FA50	22 x 58	50
45	49	ATS 48D62Y	ATS 48D75Y	NS100● MA (1)	100	LC1 D80	–	–	–	–	–
55	58	ATS 48D75Y	ATS 48D88Y	NS100● MA (1)	100	LC1D-115	–	–	–	–	–
75	75.5	ATS 48D88Y	ATS 48C11Y	NS100● MA (1)	100	LC1D-115	–	–	–	–	–
90	94	ATS 48C11Y	ATS 48C14Y	NS160● MA (1)	150	LC1D-150	–	–	–	–	–
110	113	ATS 48C14Y	ATS 48C17Y	NS160● MA (1)	150	LC1D-150	–	–	–	–	–
160	165	ATS 48C17Y	ATS 48C21Y	NS250● MA (1)	220	LC1F-265	–	–	–	–	–
200	203	ATS 48C21Y	ATS 48C25Y	NS400● MA (1)	320	LC1F-330	–	–	–	–	–
250	253	ATS 48C25Y	ATS 48C32Y	NS400● MA (1)	320	LC1F-400	–	–	–	–	–
315	321	ATS 48C32Y	ATS 48C41Y	NS630● MA (1)	500	LC1F-500	–	–	–	–	–
400	390	ATS 48C41Y	ATS 48C48Y	NS630● MA (1)	500	LC1 F630	–	–	–	–	–
500	490	ATS 48C48Y	ATS 48C59Y	NS630b● (1) Micrologic 5.0	630	LC1 BL33	–	–	–	–	–
				C801● (1) STR35 ME	800	LC1 BL33	–	–	–	–	–
560	549	ATS 48C59Y	ATS 48C66Y	NS630b● (1) Micrologic 5.0	630	LC1 BL33	–	–	–	–	–
				C801● (1) STR35 ME	800	LC1 BL33	–	–	–	–	–
630	605	ATS 48C66Y	ATS 48C79Y	NS800● (1) Micrologic 5.0	800	LC1 BP33	–	–	–	–	–
				C801● (1) STR35 ME	800	LC1 BP33	–	–	–	–	–
710	694	ATS 48C79Y	ATS 48M10Y	NS800● (1) Micrologic 5.0	800	LC1 BP33	–	–	–	–	–
				C801● (1) STR35 ME	800	LC1 BP33	–	–	–	–	–
900	880	ATS 48M10Y	ATS 48M12Y	NS1000● (1) Micrologic 5.0	1000	LC1 BR33	–	–	–	–	–
				C1001L STR35 ME	1000	LC1 BR33	–	–	–	–	–
950	1000	ATS 48M12Y	–	NS1250● (1) Micrologic 5.0	1250	LC1 BR33	–	–	–	–	–
				C1251● (1) STR35 ME	1250	LC1 BR33	–	–	–	–	–

(1) Replace ● with N, H or L, according to the breaking capacity (see table below).

Maximum prospective short-circuit current of the starter according to standard IEC 60947-4-2		Breaking capacity of circuit-breakers according to standard IEC 60947-2			
Starter	Iq (kA)	690 V Icu (kA)			
ATS 48D17Y and ATS 48C32Y	50	GV2 L20, GV2 L22, GV2 L32			
ATS 48C41Y to ATS 48M12Y	70	GK3 EF40, GK3 EF65, GK3 EF80, NS80			
		690 V Icu (kA)			
		N	H	L	
		NS100	8	10	75
		NS160, NS250	8	10	20
		NS400	10	20	75
		NS630	10	20	35
		NS800, NS1000	30	42	25
		NS1250	30	42	–
		C801, C1001	25	40	60
		C1251	25	40	–

Soft starters

Altistart 48 soft start - soft stop units

690 V power supply

Type 2 coordination

Components for use together in accordance with standards IEC 60947-4-1 and IEC 60947-4-2 (see schemes on pages 60524/2 to 60524/7) circuit-breakers, contactors, fast-acting fuses, starters

Combination: circuit-breaker, contactor, starter

Motor		Starter		Type of circuit-breaker	Rating A	Type of contactor
kW	A	Class 10 Standard applications	Class 20 Severe applications	Telemecanique <i>Merlin Gerin</i>		
M1		A1		Q1		KM1, KM2, KM3
11	12.1	–	ATS 48D17Y	NS100● MA (1)	12.5	LC1 D80
15	16.5	ATS 48D17Y	ATS 48D22Y	NS100● MA (1)	25	LC1 D80
18.5	20.2	ATS 48D22Y	ATS 48D32Y	NS100● MA (1)	50	LC1 D80
22	24.2	ATS 48D32Y	ATS 48D38Y	NS100● MA (1)	50	LC1 D80
30	33	ATS 48D38Y	ATS 48D47Y	NS100● MA (1)	50	LC1 D80
37	40	ATS 48D47Y	ATS 48D62Y	NS100● MA (1)	50	LC1 D80
45	49	ATS 48D62Y	ATS 48D75Y	NS100● MA (1)	100	LC1 D115
55	58	ATS 48D75Y	ATS 48D88Y	NS100● MA (1)	100	LC1 D115
75	75.5	ATS 48D88Y	ATS 48C11Y	NS100● MA (1)	100	LC1 D115
90	94	ATS 48C11Y	ATS 48C14Y	NS400● MA (1)	320	LC1 F265
110	113	ATS 48C14Y	ATS 48C17Y	NS400● MA (1)	320	LC1 F265
160	165	ATS 48C17Y	ATS 48C21Y	NS 400● MA (1)	320	LC1 F265
200	203	ATS 48C21Y	ATS 48C25Y	NS400● MA (1)	320	LC1 F400
250	253	ATS 48C25Y	ATS 48C32Y	NS400● MA (1)	320	LC1 F500
315	321	ATS 48C32Y	ATS 48C41Y	NS630● MA (1)	500	LC1 F500
400	390	ATS 48C41Y	ATS 48C48Y	NS630● MA (1)	500	LC1 F630
500	490	ATS 48C48Y	ATS 48C59Y	NS630bL Micrologic 5.0	630	LC1 BL33
560	549	ATS 48C59Y	ATS 48C66Y	NS630bL Micrologic 5.0	630	LC1 BL33
630	605	ATS 48C66Y	ATS 48C79Y	NS800L Micrologic 5.0	800	LC1 BP33
710	694	ATS 48C79Y	ATS 48M10Y	NS800L Micrologic 5.0	800	LC1 BP33
900	880	ATS 48M10Y	ATS 48M12Y	NS1000L Micrologic 5.0	1000	LC1 BR33
950	1000	ATS 48M12Y	–	NS1250● (1) Micrologic 5.0 (2)	1250	LC1 BR33

(1) Replace ● with N, H or L, according to the breaking capacity (see the breaking capacity table on the previous page).

(2) Type 2 coordination is only possible if the fast-acting fuses remain in the motor supply circuit and are not bypassed at the end of starting.

Fast-acting fuse (essential for type 2 coordination), starter combinations

Starter reference	Fast-acting fuses Reference	Size	Calibre A	I _t kA ² .s
A1	Q3			
ATS 48D17Y	DF3 ER50	14 x 51	50	2.3
ATS 48D22Y and ATS 48D32Y	DF3 FR80	22 x 58	80	5.6
ATS 48D38Y and ATS 48D47Y	DF3 FR100	22 x 58	100	12
DF3 ER50	DF4 00125	00	125	45
ATS 48D88Y and ATS 48C11Y	DF4 00160	00	160	82
ATS 48C14Y and ATS 48C17Y	DF4 30400	30	400	120
ATS 48C21Y to ATS 48C32Y	DF4 31700	31	700	490
ATS 48C41Y	DF4 33800	33	800	490
ATS 48C48Y and ATS 48C59Y	DF4 331000	33	1000	900
ATS 48D17Y	DF4 2331400	2 x 33	1400	1200
ATS 48C79Y	DF4 441600	44	1600	1600
ATS 48M10Y and ATS 48M12Y	DF4 442200	44	2200	4100

Maximum prospective short-circuit current of the starter according to standard IEC 60947-4-2

Starter	I _q (kA)
ATS 48D17Y	50
ATS 48M10Y and ATS 48M12Y	15
ATS 48M10Y and ATS 48M12Y	20
ATS 48D62Y and ATS 48D75Y	50
ATS 48D88Y	20
ATS 48C11Y to ATS 48C32Y	50
ATS 48C41Y	25
ATS 48C48Y to ATS 48C79Y	50
ATS 48M10Y and ATS 48M12Y	85

Summary of functions

	See pages
Starter factory setting	60526/2
Adjustment functions	See pages
Nominal motor current (maximum permanent current)	60526/3
Limiting current	60526/3
Acceleration ramp time	60526/3
Initial starting torque	60526/3
Selection of the type of stop	60526/3
Protection functions	See pages
Calculated motor thermal protection	60526/4
Reset motor thermal state	60526/4
Motor thermal protection with PTC probes	60526/4
Starter thermal protection	60526/4
Motor underload protection	60526/5
Excessive acceleration time protection	60526/5
Current overload protection	60526/5
Protection against line phase inversion	60526/5
Time before restarting	60526/5
Motor phase loss detection	60526/5
Automatic restart	60526/5
Advanced adjustment functions	See pages
Torque limit	60526/6
Voltage boost level	60526/6
Connecting the starter to the motor delta terminals	60526/6
Test on low power motor	60526/6
Activation of the cascade function	60526/6
Line frequency	60526/6
Reset kWh or the operating time	60526/6
Return to factory settings	60526/6
2nd motor adjustment functions	60526/7
Communication functions	60526/7
PowerSuite advanced dialogue solutions	60526/7
Application monitoring functions	60526/7
Logic input application functions	See pages
2-wire/3-wire control	60526/8
Freewheel stop	60526/8
External fault	60526/8
Motor preheating	60526/8
Force to local control mode	60526/8
Inhibit all protection	60526/8
Reset motor thermal fault	60526/8
Activation of the cascade function	60526/8
Reset all faults	60526/8
Logic output application functions	60526/9
Relay and analogue output application functions	60526/9
Function compatibility table	60526/9

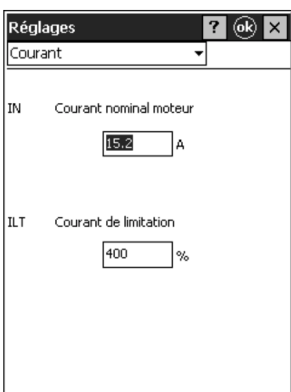

Current setting with PowerSuite on PPC

Starter factory setting

The starter is supplied ready for use in most applications. The main functions enabled and the default function values are as follows:

- Nominal motor current (depends on the starter rating)
- Limiting current: 400%
- Acceleration ramp time: 15 s
- Initial starting torque: 20%
- Selection of the type of stop: freewheel stop
- Motor thermal protection: class 10
- Time before restarting: 2 s
- Motor phase loss threshold: 10%
- Line frequency: automatic
- RUN and STOP logic inputs: 2-wire or 3-wire control via wiring
- Logic input LI3: forced freewheel stop
- Logic input LI4: local mode control (serial link disabled)
- Logic output LO1: thermal motor alarm
- Logic output LO2: motor powered
- Relay output R1: fault relay
- Relay output R3: motor powered
- Analogue output: motor current

Adjustment functions

■ **Nominal motor current** (maximum permanent current)

The nominal current of the starter can be adapted to the nominal motor current indicated on the rating plate.

Adjustment range: 0.4 to 1.3 times the starter nominal current.

■ **Limiting current**

The maximum starting current can be adjusted.

Adjustment range: 150% to 700% of the nominal motor current set and limited to 500% of the maximum permanent current defined for the starter rating.

■ **Acceleration ramp time**

During the starting phase, the Altistart 48 applies a torque ramp to the motor. The time (ACC) set corresponds to the time taken by the ramp to reach the nominal torque (starting at 0). Adjustment range: 1 to 60 s.

■ **Initial starting torque**

The initial torque tq_0 applied to the motor can be used to instantly overcome any resistive starting torque. Adjustment range: 0 to 100% of the nominal motor torque.

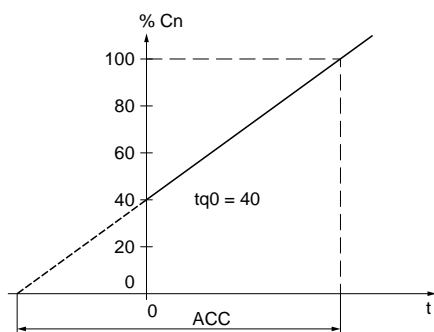

Acceleration ramp during time ACC with initial starting torque $tq_0 = 40\%$ of the nominal motor torque

■ **Selection of the type of stop**

Three types of stop are available for selection:

□ **Freewheel motor stop**

□ **Motor stop by deceleration via torque control (pump application)** This type of stop enables a centrifugal pump to be decelerated gradually on a ramp in order to avoid a sudden stop. It can be used to dampen the hydraulic transient in order to significantly reduce pressure surges.

The deceleration ramp time (dEC) can be adjusted.

During deceleration, the pump flow rate decreases and becomes negligible at a certain speed. To continue to decelerate would serve no purpose. A torque threshold (EdC) can be set at which the motor will change to freewheel stop mode, avoiding the unnecessary heating of the motor and the pump.

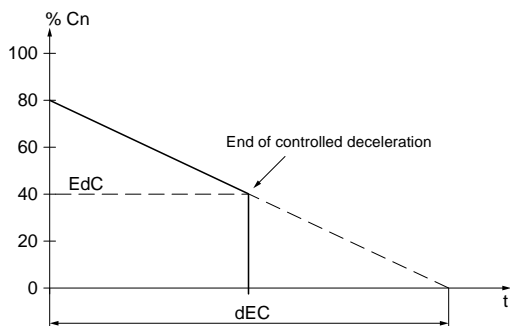

Decelerated stop by torque control during time dEC with threshold Edc for changing to freewheel stop mode
 $Edc = 40\%$ of nominal motor torque

□ **Dynamic braking motor stop (application: stopping high inertia machines)**

This type of stop will decelerate the motor if there is considerable inertia.

The braking torque level (brc) can be adjusted. The dynamic braking time (T1) corresponds to the time taken to decelerate from 100% to 20% of the nominal motor speed. To improve braking at the end of deceleration, the starter injects a d.c. current for an adjustable period of time (T2).

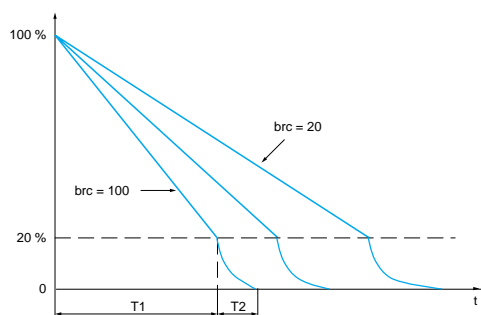

Dynamic braking stops for different braking torque levels brc

Soft starters

Altistart 48 soft start - soft stop units

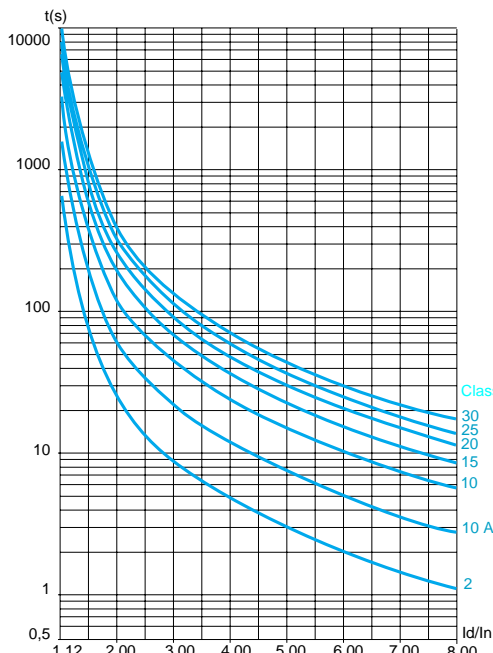

Motor thermal protection curves (cold)

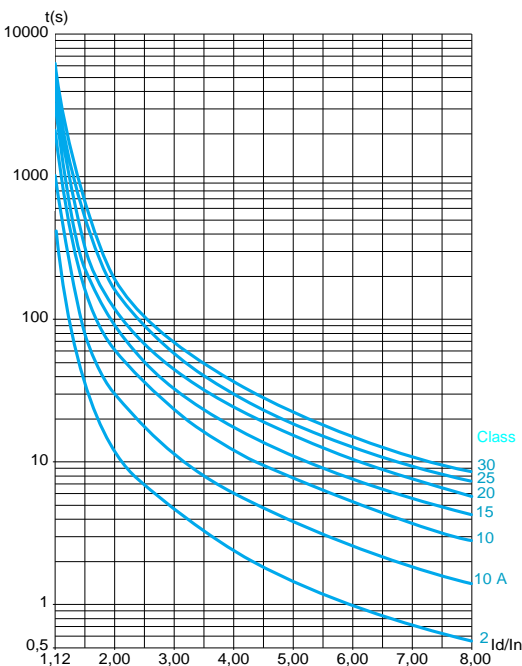

Motor thermal protection curves (warm)

Protection functions

The Altistart 48 offers functions for protecting the motor and the machine.

Calculated motor thermal protection

The starter continuously calculates the temperature rise of the motor based on the nominal current which has been set and the actual current absorbed. In order to adapt the Altistart to individual motors and applications, several protection classes are offered in accordance with standard IEC 60947-4-2:

class 30, class 25, class 20 (severe application), class 15, class 10 (standard application), class 10 A, sub-class 2.

Different protection classes are defined for the starting capacities of the motor:

- cold start without thermal fault (corresponding to a stabilised motor thermal state, motor switched off)
- warm start without thermal fault (corresponding to a stabilised motor thermal state, at nominal power)

The motor thermal protection function can be disabled.

After the motor has stopped or the starter has been switched off, the thermal state is calculated even if the control circuit is not energised. The Altistart thermal control prevents the motor from restarting if the temperature rise is too high. If special motors are used which do not have thermal protection via curves, provide external thermal protection via probes or thermal overload relays.

The starter is factory-set to protection class 10.

The tripping curves are based on the relationship between the starting current I_s and the (adjustable) nominal motor current I_n .

Trip time (cold)

Trip time for a standard application (class 10)			Trip time for a severe application (class 20)		
$I_s = 3 I_n$	$I_s = 4 I_n$	$I_s = 5 I_n$	$I_s = 3.5 I_n$	$I_s = 4 I_n$	$I_s = 5 I_n$
46 s	23 s	15 s	63 s	48 s	29 s

Trip time (warm)

Trip time for a standard application (class 10)			Trip time for a severe application (class 20)		
$I_s = 3 I_n$	$I_s = 4 I_n$	$I_s = 5 I_n$	$I_s = 3.5 I_n$	$I_s = 4 I_n$	$I_s = 5 I_n$
23 s	12 s	7.5 s	32 s	25 s	15 s

Reset motor thermal state

Activating the function resets the motor thermal state calculated by the starter to zero.

Motor thermal protection with PTC probes

The starter integrates the processing of PTC probes, thus avoiding the use of an external device. The "PTC probe thermal overshoot" fault or alarm can be indicated using a configurable logic output or displayed via the serial link. The function can be disabled.

Note: The "PTC probe protection" and "calculated motor thermal protection" functions are independent and can be active simultaneously.

■ **Starter ventilation:** The cooling fan on the starter is switched on as soon as the heatsink temperature reaches 50°C. It is switched off when the temperature returns to 40°C.

Starter thermal protection

The starter is protected against thermal overloads by an analogue thermal probe.

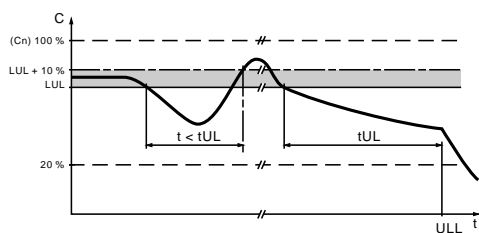

Motor underload detection (ULL)

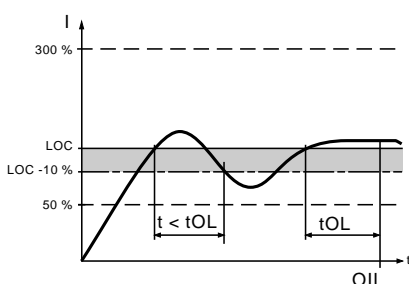

Motor overcurrent detection (OIL)

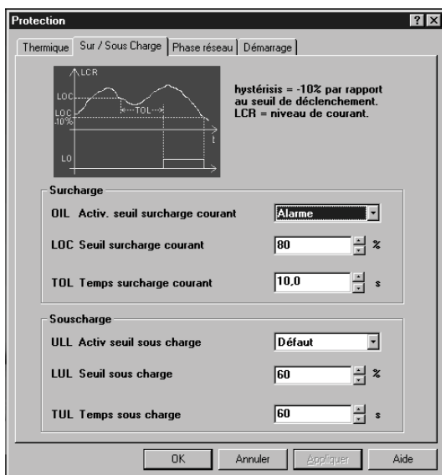

Configuring the starter overload and underload with PowerSuite on a PC

Protection functions (continued)

■ Motor underload protection

The starter detects a motor underload if the motor torque falls below a preset torque threshold (LUL) for a specific (adjustable) period of time (tUL). The motor underload threshold can be set between 20% and 100% of the nominal motor torque. The permissible underload duration can be set between 1 and 60 s. The detection function can trigger an alarm or a fault. The detection function can be disabled. The "motor underload detected" alarm can be indicated by a configurable logic output and/or displayed via the serial link in the state of the starter. The "motor underload detected" fault (ULF) locks the starter and can be displayed via the serial link.

■ Excessive acceleration time protection

This protection function can be used to detect a start which takes place in adverse conditions. Examples of such conditions include a locked rotor or a motor unable to reach its nominal rotation speed. If the start duration is greater than the value set (between 10 and 999 s), the drive changes to fault mode. The function can be disabled.

■ Current overload protection

The starter detects a current overload if the motor current exceeds a preset overcurrent threshold (LOC) for a specific (adjustable) period of time (tOL). The overcurrent threshold can be set between 50% and 300% of the nominal motor current. The permissible overcurrent duration can be set between 0.1 and 60 s. This function is only active in steady state. The detection function can trigger an alarm or a fault. It can also be disabled. The "current overload detected" alarm can be indicated by a configurable logic output and/or displayed via the serial link. The "current overload detected" fault (OLC) locks the starter and can be displayed via the serial link in the state of the starter.

■ Protection against line phase inversion

This function can be used to detect the direction of rotation of the motor phases and, if it is enabled, to indicate a fault when the direction of rotation is reversed.

■ Time before restarting

This function can be used to avoid several consecutive starts which may cause:

- the thermal overheating of the application, which is not permitted
- a thermal fault which will require maintenance work to be carried out
- overcurrents (if the direction of rotation is reversed) or repeats (run/stop commands)

Following a stop command, the motor can only restart once the preset time delay has elapsed. The motor is restarted once the time delay has elapsed if a run command is still valid or if a new run command is sent. Adjustment range: 0 to 999 s.

■ Motor phase loss detection

The function is used to adjust the sensitivity of the protection function in order to detect a loss of current or a low current in one of the three motor phases for at least 0.5 s or in all three motor phases for at least 0.2 s. The value of the minimum current level can be set between 5% and 10% of the starter nominal current.

■ Automatic restart

After locking on a fault, the function permits up to six restart attempts at intervals of 60 s if the fault has disappeared and the run commands are still present. After the sixth attempt, the starter will remain locked and the fault will have to be reset before a restart is permitted. If the function is active, the fault relay remains activated if line phase loss, motor phase loss or line frequency out of tolerance faults are detected. This function can only be used in 2-wire control.

Advanced adjustment functions

■ Torque limit

Designed primarily for high inertia and constant torque conveyor applications, the function restricts the torque ramp reference to the preset value.

For example, the function can be used to limit the torque to a constant value throughout the starting period.

Adjustment range: 10% to 200% of the nominal motor torque.

■ Voltage boost level

The function can be used to avoid any "starting" torque (phenomenon caused by friction on stopping or by mechanical play). When a run command is sent, the starter applies a fixed voltage to the motor for a limited period of time before starting. The function can be disabled.

The voltage setting value varies between 50% and 100% of the nominal motor voltage.

■ Connecting the starter to the motor delta terminal

ATS48●●Q starters connected to motors with delta terminals can be wired in series in the motor windings. This type of connection reduces the current in the starter by a ratio of $\sqrt{3}$, which enables a lower rating starter to be used. The nominal current and limiting current settings as well as the current displayed during operation are on-line values and are indicated on the motor. For this application, the braking or decelerating stop functions are inactive. Only freewheel stopping is possible. The adjustment range of the nominal motor current and the limiting current are multiplied by $\sqrt{3}$ if the function is selected.

This function is not compatible with the following functions: motor phase loss detection, motor preheating, cascade, decelerated stop and dynamic braking.

Use the scheme recommended on page 60524/4 for this type of configuration.

■ Test on low power motor

This function can be used to test a starter on a motor whose power is very much lower than that of the starter. It can be used for example to check the electrical wiring of a device.

The function is automatically cancelled when the starter is switched off.

The next time the starter is switched on, the starter returns to its initial configuration.

■ Activation of the cascade function

This function can be used to start and decelerate several cascaded motors with a single starter.

In order to gain maximum benefit from torque control, it is advisable to use motors with powers between 0.5 and 1 times the power of the motor.

The wiring diagram for the cascaded motor function is shown on page 60524/6.

This function is not compatible with the following functions: motor preheating and connection to the motor delta terminal.

■ Line frequency

The following frequencies can be selected for the function:

- 50 Hz. The frequency fault monitoring tolerance is $\pm 20\%$.

- 60 Hz. The frequency fault monitoring tolerance is $\pm 20\%$.

- Automatic detection of the line frequency by the starter. The frequency fault monitoring tolerance is $\pm 6\%$.

50 Hz and 60 Hz are recommended if the power supply is provided by a generating set, given their high tolerance.

■ Reset kWh or the operating time

Sets the value of the power in kWh or the operating time value to 0. The calculation of the values is updated once the reset command has been sent.

■ Return to factory settings

The function can be used to reset each setting to its initial value (starter factory setting, see page 60526/2).

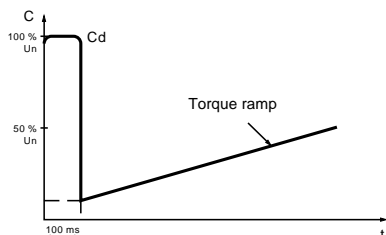

Application of a voltage boost equal to 100% of the nominal motor voltage

Soft starters

Altistart 48 soft start - soft stop units

2nd motor adjustment functions

In order to access the 2nd motor adjustment functions, one logic input must be assigned to the second set of motor parameters function. The adjustment functions and ranges are identical for both sets of motor parameters.

The settings are as follows (see page 60526/3):

- Nominal motor current
- Limiting current
- Acceleration ramp time
- Initial starting torque
- Deceleration ramp time
- Threshold for changing to freewheel stop mode at the end of deceleration
- Maximum torque limit

Communication functions

The Altistart 48 is supplied with an RS 485 multidrop serial link with Modbus protocol as standard. The serial link is configured in the Communication menu using:

- The address of the starter, which can be set between 0 and 31
- The communication speed, which can be set at: 4800, 9600 or 19200 bps
- The format of the communication data. The following formats can be selected:
 - 8 data bits, odd parity, 1 stop bit
 - 8 data bits, even parity, 1 stop bit
 - 8 data bits, no parity, 1 stop bit
 - 8 data bits, no parity, 2 stop bits
- The time-out, which can be set between 1 and 60 s

PowerSuite advanced dialogue solutions

The PowerSuite advanced dialogue solutions (see pages 60200/2 and 60200/3) offer the following advantages:

- Connection to the Altistart 48 and access to the adjustment, monitoring and control functions
- Display of messages in plain text in 5 languages (English, French, German, Spanish and Italian)
- Preparation and saving of settings to hard disk
- Comparison and editing of settings using office automation tools
- Downloading of starter settings to the PC and uploading from the PC to the starter

Application monitoring functions

The monitoring functions provide the following information:

- Cosine ϕ , displayed between 0.00 and 1.00
- Motor thermal state: 100% corresponds to the thermal state of the motor consuming the permanently set nominal current
- Motor current: displayed in amperes between 0 and 999 A and in kilo amperes between 1000 and 9999 A
- The operating time corresponding to the total number of starter operating hours during heating, acceleration, steady state, deceleration, braking and continuous bypass operation. It is displayed in hours between 0 and 999 hours and in kilo hours between 1000 and 65536 hours.
- The active power is displayed between 0 and 255%, where 100% corresponds to the power at the set nominal current and at full voltage.
- The motor torque is displayed between 0 and 255%, where 100% corresponds to the nominal torque.
- The active power consumed is displayed in kW. The line voltage value must be configured. The accuracy of this setting will depend on the error between the voltage configured and the actual voltage.
- Power in kW/h displayed with PowerSuite
- The following starter states are shown in the display of the current state:
 - Starter without run command and power not supplied
 - Starter without run command and power supplied
 - Acceleration/deceleration in progress
 - Steady state operation
 - Braking in progress
 - Starter in current limiting mode
 - Starting time delay not elapsed
 - Last fault. Displays the last fault which occurred.
 - Phase rotation direction. Displays the direction of rotation (direct or indirect).
 - **Terminal locking code**
 - An access code can be used to protect access to the adjustment and configuration parameters of the starter. Only the monitoring parameters will then be visible.

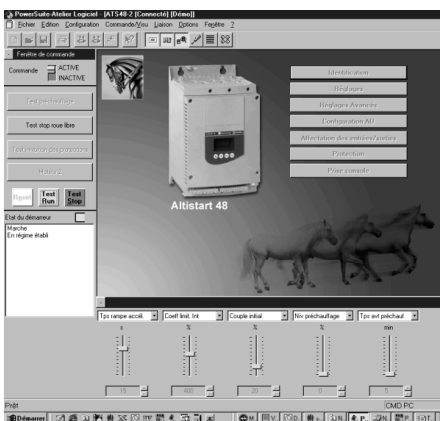

Displaying the commands and settings with PowerSuite on PC

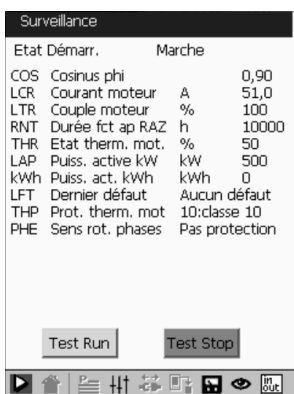

Monitoring the parameters with PowerSuite on PPC

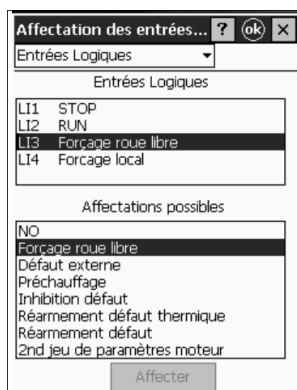

Assigning the logic inputs with PowerSuite on PPC

Logic input application functions

The starter has 4 logic inputs:

- **2 logic inputs (RUN and STOP) are reserved for run/stop commands** which can be sent in the form of stay-put contacts or as pulsed contacts.
 - **2-wire control:** Starting and stopping are controlled by a single logic input. State 1 of the logic input controls starting and state 0 controls stopping.
 - **3-wire control:** Starting and stopping are controlled by 2 separate logic inputs. A stop is obtained on opening (state 0) the STOP input. The pulse on the RUN input is stored until the stop input opens.

- **2 logic inputs (LI3 and LI4) can be configured with the following functions:**

- **Freewheel stop:** When combined with a braked stop or decelerated stop command, activating the logic input will stop the motor in freewheel mode.
- **External fault:** Enables the starter to detect an external user fault (level, pressure, etc.). When the contact is open, the starter changes to fault mode.
- **Motor preheating:** Used to prevent the motor from freezing or to prevent temperature variations which may cause condensation. When the logic input is activated, an adjustable current flows through the motor after a time delay which can be set between 0 and 999 s. This current heats the motor without causing it to rotate. This function is not compatible with the following functions: connection to the motor delta terminal and cascading.
- **Force to local control mode:** If a serial link is used, this function can be used to change from line mode (control via serial link) to local mode (control via the terminal).
- **Inhibit all protection:** Enables the forced operation of the starter in an emergency by overriding the main faults (smoke extraction system for example).
Warning: This type of use invalidates the starter warranty.
- **Reset motor thermal fault:** Enables the fault to be reset remotely.
- **Activation of the cascade function:** In this case, the motor thermal protection is disabled and relay R1 is configured as the fault isolation relay. Can be used to start and decelerate several motors one after the other with a single starter (see application diagram on pages 60524/6 and 60524/7).
- **Reset all faults:** Enables all faults to be reset remotely.
- **Second set of motor parameters:** Enables a second set of parameters to be selected to start and decelerate two different motors with a single starter.

Logic output application functions

The starter has 2 logic outputs (LO1 and LO2) which, depending on their configuration, can be used for remote indication of the following states or events:

- Motor thermal alarm: Indicates that the motor thermal state has exceeded the alarm threshold and can be used for example to avoid starting a motor if the thermal reserve is insufficient.
- Motor powered: Indicates that there may be current in the motor.
- Motor overcurrent alarm: The motor current is higher than the threshold set.
- Motor underload alarm: The motor torque is lower than the threshold set.
- Motor PTC probe alarm: Indicates that the thermal state monitored by the PTC motor probe has been exceeded.
- Second set of motor parameters activated

Relay and analogue output application functions

The starter has 3 relays, 2 of which are configurable.

- **End of starting relay R2:** Cannot be configured. The end of starting relay controls the bypass contactor on the starter. It is activated when the motor has completed the starting phase. It is deactivated when a stop command is sent and in the event of a fault. The starter regains control when a braking or deceleration command is sent.

■ Relay R1 application functions

Relay R1 can be configured as follows:

- Fault relay: Relay R1 is activated when the starter is powered and there are no faults. It is deactivated when a fault occurs and the motor switches to freewheel mode.
- Isolating relay: The contact of relay R1 closes when a run command is sent and re-opens when a stop command is sent, at the end of deceleration on a decelerated stop or in the event of a fault. The line contactor is deactivated and the motor is isolated from the line supply (see application diagram page 60524/3).

■ Relay R3 application functions

Relay R3 is configured to indicate the same states or events as logic outputs LO1 or LO2 (see above).

■ Analogue current output AO application functions

- The analogue output AO provides an image of the following values: motor current, motor torque, motor thermal state, cosine ϕ , active power.
- The following settings are associated with the analogue output:
 - the type of signal supplied: 0-20 mA or 4-20 mA
 - the scale setting of the signal. The function associates the maximum amplitude of the analogue output (20 mA) with a percentage of the nominal value of the parameter, which can be set between 50% and 500%.

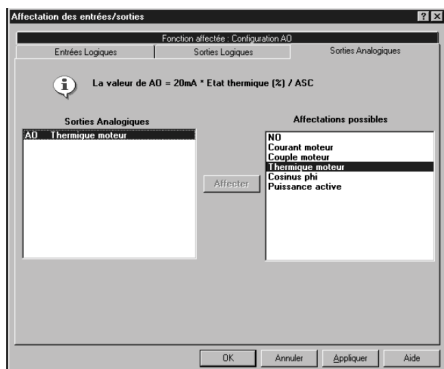

Assigning the analogue output with PowerSuite on PC

Function compatibility table

Functions	Decelerating stop	Dynamic braking stop	Forced freewheel stop	Thermal protection	Motor phase loss detection	Connection to the motor delta terminal	Tests on low power motor	Cascaded motors	Motor preheating
Decelerating stop									
Dynamic braking stop									
Forced freewheel stop									
Thermal protection									(1)
Motor phase loss detection						(1)			(1)
Connection to the motor delta terminal					(1)				
Tests on low power motor									
Cascaded motors									
Motor preheating				(2)	(1)				

- Compatible functions
- Incompatible functions
- Not applicable

(1) Motor phase loss not detected.
 (2) Thermal protection is not provided during motor preheating.

Soft starters

Conventional starting of three-phase asynchronous motors

Direct starting

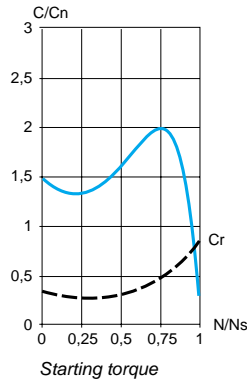
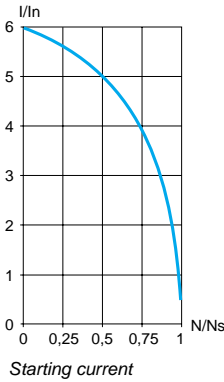

- Starting current: 4 to 8 times the nominal current
- Starting torque: 0.5 to 1.5 times the nominal torque
- Characteristics:
 - Motor with 3 terminals, low and medium power
 - On-load starting
 - High current peak and voltage drop
 - Simple device
 - Sudden starting for the mechanism
- No parameter adjustment

"Star-delta" starting

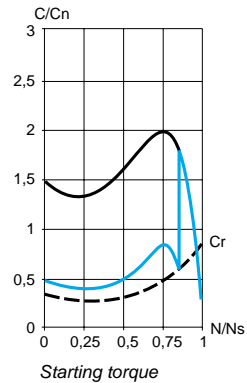
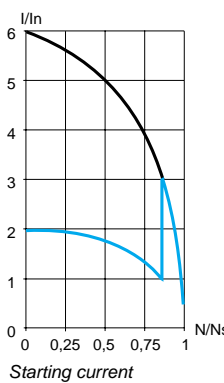

- Starting current: 1.8 to 2.6 times the nominal current
- Starting torque: 0.5 times the nominal torque
- Characteristics:
 - Motor with 6 terminals
 - No-load or low resistive torque starting
 - High current peaks and torque when changing to "star-delta" mode
 - A device requiring maintenance
 - Subject to mechanical stress when starting
- No parameter adjustment

Rheostatic stator starting

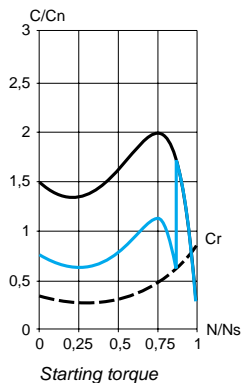
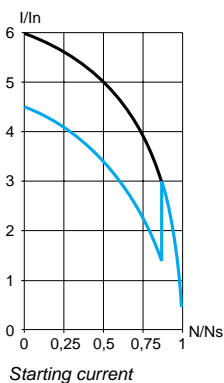

- Starting current: 4.5 times the nominal current
- Starting torque: 0.5 to 0.75 times the nominal torque
- Characteristics:
 - Motor with 3 terminals, high power
 - Starting with increasing resistive torque
 - High current peak
 - A large, bulky device requiring maintenance
 - Subject to mechanical stress when starting
- No parameter adjustment

Auto transformer starting

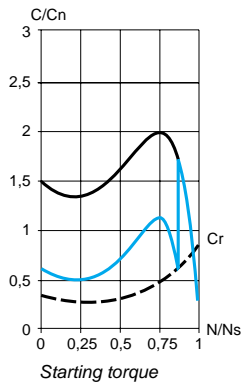
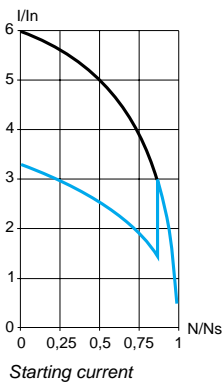

- Starting current: 1.7 to 4 times the nominal current
- Starting torque: 0.4 to 0.85 times the nominal torque
- Characteristics:
 - Motor with 3 terminals, high power
 - Large voltage drop and current peak when connected at full voltage
 - A complex, bulky device requiring maintenance
 - Subject to mechanical stress when starting
- No parameter adjustment

Soft starters

Progressive starting of three-phase asynchronous motors

Conventional electronic starting with variable voltage and current limiting

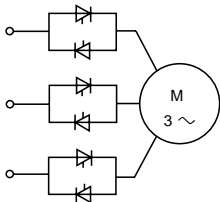

Schematic diagram

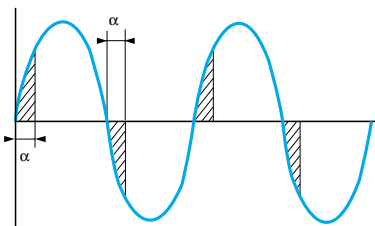

Firing angle

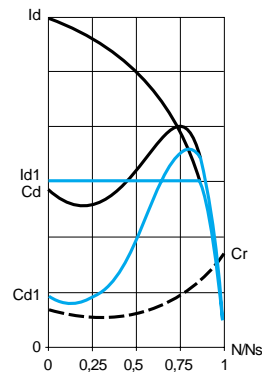

Figure 1

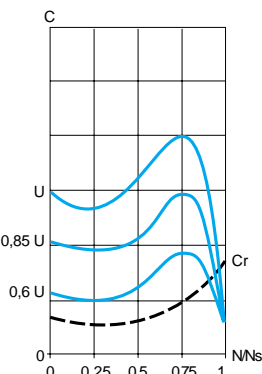

Figure 2

- A controller with 6 thyristors connected head to tail in each line phase is used to power the three-phase asynchronous motor by gradually increasing the voltage on start-up.
- Depending on the firing time and angle of the thyristors, it can be used to supply a voltage which will gradually increase at a fixed frequency.
- The gradual increase in the output voltage can either be controlled by the acceleration ramp, or by the value of the limiting current, or linked to both parameters.

- Figure 1 shows the behaviour of the torque in relation to the starting current. Limiting the starting current I_s to a preset value I_{s1} will reduce the starting torque T_{s1} to a value which is almost equal to the ratio of the square of currents I_s and I_{s1} .

Example

On a motor with the following characteristics: $T_s = 2 T_n$ for $I_s = 6 I_n$, current limiting at $I_{s1} = 3 I_n$ or $0.5 I_s$ results in a starting torque: $T_{s1} = T_s \times (0.5)^2 = 2 T_n \times 0.25 = 0.5 T_n$.

- Figure 2 shows the torque/speed characteristic of a squirrel cage motor in relation to the supply voltage. The torque varies like the square of the voltage at a fixed frequency. The gradual increase in the voltage prevents the instantaneous current peak on power-up.

Advantages of starting with the Altistart 48

- Conventional electronic starting
To rectify problems caused by:
 - mechanical stress when starting
 - hydraulic transients during acceleration and deceleration in pump applications
 Conventional electronic starting requires the use of several current limits or the switching of several voltage ramps.
The settings become complicated and must be modified every time the load changes.
- Starting with the Altistart 48
The Altistart 48 torque control enables starting without mechanical stress and the smooth control of hydraulic transients with a single acceleration ramp.
The settings are simple and effective, whatever the load.

Soft starters

Altistart 48 soft start - soft stop units

Options: Communication modules

Presentation

The Altistart 48 can be connected directly to the Modbus bus using an RJ45 connector and communicates using the RS 485 serial link (2-wire) and the Modbus RTU protocol. The communication function provides access to the configuration, adjustment, control and signalling functions of the starter.

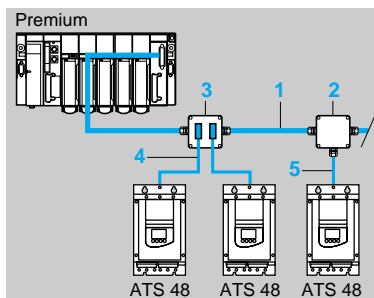

- 1 Modbus cable **TSX SCA 000**
- 2 Junction box **TSX SCA 50**
- 3 Subscriber sockets **TSX SCA 62**
- 4 Modbus drop cable **VW3 A8 306**
- 5 Modbus drop cable **VW3 A8 306 D30**

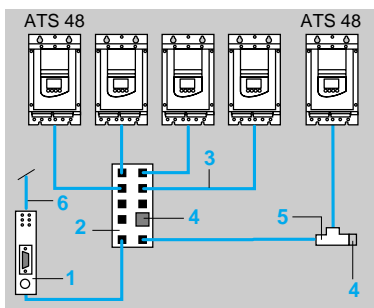

- 1 Communication module
- 2 Modbus hub **LU9 GC3**
- 3 Modbus drop cable **VW3 A8 306 R00**
- 4 Line terminator **VW3 A8 306 RC**
- 5 Modbus T-junction box **VW3 A8 306 TF3**
- 6 To other buses or networks

The Altistart 48 can be connected to other buses or networks using the communication modules and accessories below.

References

Communication modules	Cables to be connected	Reference	Weight kg
Ethernet/Modbus bridge with 1 x Ethernet 10baseT port (RJ45 type)	To be connected using cable VW3 P10 306 R10	174 CEV 300 10	0.500
FIPIO/Modbus gateway	To be connected using cables VW3 A8 306 R00	LUF P1 ▲	0.240
DeviceNet/Modbus gateway	To be connected using cables VW3 A8 306 R00	LUF P9 ▲	0.240
Profibus DP/Modbus gateway	To be connected using cable VW3 P07 306 R10	LA9 P307	0.240
Connection accessories	Connectors	Reference	Weight kg
Junction box (to be connected with cable VW3 A8 306 D30)	3 screw terminals	TSX SCA 50	0.520
2-channel subscriber sockets (to be connected with cable VW3 A8 306)	2 15-way female SUB-D connectors and 2 screw terminals	TSX SCA 62	0.570
Modbus hub	8 RJ45 connectors	LU9 GC3 ▲	0.500
Line terminator	–	VW3 A8 306 RC	–
Modbus T-junction box	–	VW3 A8 306 TF3	–
Connecting cables	Connectors	Reference	Weight kg
For bus and networks			
Modbus	3	1 RJ45 connector and one end stripped	VW3 A8 306 D30 0.150
	3	1 RJ45 connector and 1 15-way male SUB-D connector	VW3 A8 306 0.150
FIPIO, DeviceNet	0.3	2 RJ45 connectors	VW3 A8 306 R03 0.050
Modbus	1	2 RJ45 connectors	VW3 A8 306 R10 0.050
	3	2 RJ45 connectors	VW3 A8 306 R30 0.150
Profibus DP	1	2 RJ45 connectors	VW3 P07 306 R10 0.050
Ethernet	1	2 RJ45 connectors	VW3 P10 306 R10 0.050

▲ To be launched 3rd quarter 2002.



174 CEV 300 10



LUF P1

Soft starters

Altistart 48 soft start - soft stop units

Options: Remote terminal, line chokes, protective covers, documentation



VW3 G48101

Remote terminal

The terminal can be mounted on the door of a wall-fixing or floor-standing enclosure. It has the same signalling display and configuration buttons as the terminal integrated in the starter. A switch to lock access to the menu is located at the rear of the terminal.

The option comprises:

- the remote terminal
- a mounting kit containing a cover, screws and an IP 54 seal on the front panel
- a 3 m connecting cable with a 9-way SUB-D connector for connecting to the terminal and an RJ45 connector for connecting to the Altistart 48

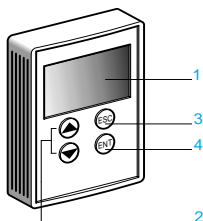

- 1 Information is displayed in the form of codes or values in three "7-segment" displays
- 2 Buttons for scrolling through the menus or modifying values
- 3 "ESC": Button for exiting the menus (cannot be used for validation purposes)
- 4 "ENT": Validation button for entering a menu or confirming the new value selected

Reference

Description	Reference	Weight kg
Remote terminal	VW3 G48101	0.200

Line chokes

The use of line chokes is recommended in particular when installing several electronic starters on the same line supply. The values of the chokes are defined for a voltage drop between 3% and 5% of the nominal line voltage. Install the line choke between the line contactor and the starter.

References

For starters	Value of the choke mH	Nominal current A	Degree of protection	Reference	Weight kg
ATS 48D17●	1.7	15	IP 20	VZ1 L015UM17T	2.100
ATS 48D22●	0.8	30	IP 20	VZ1 L030U800T	4.100
ATS 48D32● and 48D38●	0.6	40	IP 20	VZ1 L040U600T	5.100
ATS 48D47● and 48D62●	0.35	70	IP 20	VZ1 L070U350T	8.000
ATS 48D75● to 48C14●	0.17	150	IP 00	VZ1 L150U170T	14.900
ATS 48C17● to 48C25●	0.1	250	IP 00	VZ1 L250U100T	24.300
ATS 48C32●	0.075	325	IP 00	VZ1 L325U075T	28.900
ATS 48C41● and 48C48●	0.045	530	IP 00	VZ1 L530U045T	37.000
ATS 48C59● to 48M10●	0.024	1025	IP 00	VZ1 LM10U024T	66.000
ATS 48M12●	0.016	1435	IP 00	VZ1 LM14U016T	80.000

Note: Line chokes with IP 00 degree of protection must be fitted with a protective bar to protect personnel against electrical contact.

Protective covers for power terminals

To be used with tags closed

References

For starters	Number of covers per set	Reference	Weight kg
ATS 48C14● and ATS 48C17●	6 (1)	LA9 F702	0.250
ATS 48C21●, ATS 48C25● and ATS 48C32●	6 (1)	LA9 F703	0.250

(1) The starters have 9 unprotected power terminals.

Note:

Documentation

Description	Format	Reference	Weight kg
Altistart 48 user's manual	A5	VVD ED 301066	0.150
Modbus user's manual	A5	VVD ED 302023	0.150
Ethernet, FIPIO, DeviceNet, Profibus DP user's manuals	CD-ROM	DCI CD 398111	0.150

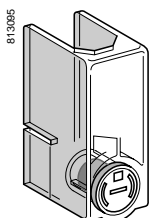

LA9 F702

Soft starters

Altistart 48 soft start - soft stop units

Selection criteria for an Altistart 48 soft start - soft stop unit

The Altistart 48 must be selected on the basis of 3 main criteria:

- Two line power supply voltage ranges are available for selection:
 - Three-phase a.c. voltage: 230 - 415 V
 - Three-phase a.c. voltage: 208 - 690 V
- The power and the nominal current indicated on the motor name plate
- The type of application and the operating cycle:
To simplify selection, the applications are categorised into 2 types:
 - Standard applications
 - Severe applicationsStandard or severe applications define the limiting values of the current and the cycle for motor duties S1 and S4.

Standard application

In standard applications, the Altistart 48 is designed to provide:

- Starting at 4 In for 23 seconds or at 3 In for 46 seconds from a cold state (corresponding to motor duty S1)
- Starting at 3 In for 23 seconds or at 4 In for 12 seconds with a load factor of 50% and 10 starts per hour or an equivalent thermal cycle (corresponding to motor duty S4)
The motor thermal protection must conform to protection class 10 (see page 60526/4).
Example: centrifugal pump

Severe application

In severe applications, the Altistart 48 is designed to provide:

- Starting at 4 In for 48 seconds or at 3 In for 90 seconds from a cold state (corresponding to S1 motor duty)
- Starting at 4 In for 25 seconds with a load factor of 50% and 5 starts per hour or an equivalent thermal cycle (corresponding to S4 motor duty)
The motor thermal protection must conform to protection class 20 (see page 60526/4).
Example: grinder

Motor duties

S1 motor duty corresponds to starting followed by operation at constant load enabling the thermal equilibrium to be reached.

S4 motor duty corresponds to a cycle comprising starting, operation at constant load and an idle period.

This cycle is characterised by a load factor of 50%.

Selecting the starter

Once the appropriate application has been selected from the following page, select the starter from pages 60522/2 to 60522/5 according to the supply voltage and the motor power.

Caution:

If the Altistart 48 is installed inside an enclosure, observe the mounting and derating recommendations (see page 60523/5).

Application areas

Depending on the type of machine, the applications are categorized as standard or severe based on the starting characteristics, which are given as examples only, in the table below.

Type of machine	Application	Functions performed by the Altistart 48	Starting current (% I _n)	Starting time (s)
Centrifugal pump	Standard	Deceleration (reduction in pressure surges) Protection against underloads or inversion of the phase rotation direction	300	5 to 15
Piston pump	Standard	Control of running dry and direction of rotation of the pump	350	5 to 10
Fan	Standard Severe if > 30 s	Detection of overloads caused by clogging or underloads (motor fan transmission broken) Braking torque on stopping	300	10 to 40
Cold compressor	Standard	Protection, even for special motors	300	5 to 10
Screw compressor	Standard	Protection against inversion of direction of phase rotation Contact for automatic draining on stopping	300	3 to 20
Centrifugal compressor	Standard Severe if > 30 s	Protection against inversion of direction of phase rotation Contact for automatic emptying on stopping	350	10 to 40
Piston compressor	Standard	Protection against inversion of direction of phase rotation Contact for automatic emptying on stopping	350	5 to 10
Conveyor, transporter	Standard	Overload control for detecting faults or underload control for detecting breaks	300	3 to 10
Lifting screw	Standard	Overload control for detecting hard spots or underload control for detecting breaks	300	3 to 10
Drag lift	Standard	Overload control for detecting jamming or underload control for detecting breaks	400	2 to 10
Lift	Standard	Overload control for detecting jamming or underload control for detecting breaks Constant starting with variable load	350	5 to 10
Circular saw, band saw	Standard Severe if > 30 s	Braking for fast stop	300	10 to 60
Pulper, butchery knife	Severe	Torque control on starting	400	3 to 10
Agitator	Standard	The current display indicates the density of the product	350	5 to 20
Mixer	Standard	The current display indicates the density of the product	350	5 to 10
Grinder	Severe	Braking to limit vibrations during stopping, overload control to detect jamming	450	5 to 60
Crusher	Severe	Braking to limit vibrations during stopping, overload control to detect jamming	400	10 to 40
Refiner	Standard	Torque control on starting and stopping	300	5 to 30
Press	Severe	Braking to increase the number of cycles	400	20 to 60

Special uses

Other criteria can influence the selection of the Altistart 48:

Starter wired to the motor delta terminal

(see the recommended application diagram on page 60524/4)

In addition to the most frequently encountered wiring layouts, where the starter is installed in the line supply of the motor and the motor is connected in star or delta configuration, the Altistart 48 ATS48***Q can be wired to the motor delta terminal in series with each winding (see the application diagram below). The starter current is lower than the line current absorbed by the motor by a ratio of $\sqrt{3}$. This type of installation enables a starter with a lower rating to be used.

Example: For a 400 V/110 kW motor with a line current of 195 A (nominal current for the delta connection), the current in each winding is equal to $195/\sqrt{3}$, i.e. 114 A. Select the starter rating with a maximum permanent nominal current just above this current, i.e. 140A (ATS48C14Q for a standard application).

To avoid making this calculation, simply use the table on page 60522/3.

This type of installation only permits freewheel stopping and is not compatible with the cascade and preheating functions.

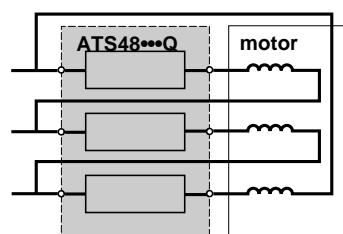

Starter wired in series with the motor windings

Note: The nominal current and limiting current settings as well as the current displayed during operation are on-line values (so do not have to be calculated by the user).

Caution: For this type of installation, observe the wiring scheme and the associated recommendations on page 60524/4.

Starter bypassed by a contactor

(see the recommended application diagram on page 60524/3)

The starter can be bypassed by a contactor at the end of starting (to limit the heat dissipated by the starter). The bypass contactor is controlled by the starter and the current measurements and protective mechanisms remain active when the starter is bypassed.

The starter is selected on the basis of the 3 main criteria and one of the following criteria:

- If the starter is bypassed at the end of starting, the motor is always started from cold state and the starter can be oversized by one rating.

Example: Select an ATS 48D17Q for an 11 kW motor in a standard 400 V application.

- If the starter must be able to operate without the bypass contactor at the end of starting, it does not have to be derated.

Example: Select an ATS 48D17Q for a 7.5 kW motor in a standard 400 V application.

Special uses (continued)

Motors in parallel

Motors may be connected in parallel provided that the power limit of the starter is not exceeded (the sum of the motor currents must not exceed the nominal current of the starter selected depending on the type of application). Provide thermal protection for each motor.

Brush motor

The Altistart 48 can operate with a bypassed stator resistance motor or with a resistance lug. The starting torque is modified in accordance with the rotor resistance. If necessary, maintain a low resistance in order to obtain the required torque to overcome the resistive torque on starting.

A bypassed brush motor has a very low starting torque. A high stator current is required to obtain the sufficient starting torque.

Oversize the starter in order that the value of the limiting current is 7 times that of the nominal current.

Note: Ensure that the starting torque of the motor, equal to 7 times the nominal current, is greater than the resistive torque.

Note: The Altistart 48 torque control enables excellent soft starting despite the limiting current being 7 times the nominal current required to start the motor.

Dahlander motor and 2-speed motor

The Altistart 48 can operate with a 2-speed motor. A motor demagnetisation period must elapse before changing from low speed to high speed in order to avoid antiphases between the line supply and the motor, which would generate very high currents.

Select the starter using the 3 main criteria.

Very long cable

Very long motor cables cause voltage drops due to the resistance of the cable. If the voltage drop is significant, it could affect the current consumption and the torque available. This must therefore be taken into account when selecting the motor and the starter.

Starters in parallel on the same line supply

If several starters are installed on the same line supply, line chokes should be installed between the transformer and the starter (see page 60528/3).

Recommendations for use

Caution: Do not use the Altistart 48 upstream of loads other than motors (for example transformers and resistors are forbidden).

Do not connect power factor correction capacitors to the terminals of a motor controlled by an Altistart 48.